



Microprocessor Reset IC

Features

- Precision Monitoring of +3V, +3.3V, and +5V Power-Supply Voltages
- Fully Specified Over Temperature
- Available in Three Output Configurations
Push-Pull $\overline{\text{RESET}}$ Output (G696L)
Push-Pull RESET Output (G696H)
Open-Drain $\overline{\text{RESET}}$ Output (G697L)
- Externally Programmable Time Delay Generator
- 6 μA Supply Current
- Guaranteed Reset Valid to $V_{\text{CC}} = 0.8\text{V}$
- Power Supply Transient Immunity
- 5 pin SOT23-5 Packages

Applications

- Computers
- Controllers
- Intelligent Instruments
- Critical μP and μC Power Monitoring
- Portable / Battery-Powered Equipment
- Automotive

General Description

The G696/G697 are microprocessor (μP) supervisory circuits used to monitor the power supplies in μP and digital systems. They provide excellent circuit reliability and low cost and adjustments when used with +5V, +3.3V, +3.0V- powered circuits.

These circuits perform a single function: they assert a reset signal whenever the V_{CC} supply voltage declines below a preset threshold, with hysteresis keeping it asserted for time delay determined by externally programmable time delay generator. after V_{CC} has risen above the reset threshold. Reset thresholds suitable for operation with a variety of supply voltages are available.

The G697L has an open-drain output stage, while the G696 have push-pull outputs. The G697L's open-drain $\overline{\text{RESET}}$ output requires a pull-up resistor that can be connected to a voltage higher than V_{CC} . The G696L have an active-low $\overline{\text{RESET}}$ output, while the G696H has an active-high RESET output. The reset comparator is designed to ignore fast transients on V_{CC} , and the outputs are guaranteed to be in the correct logic state for V_{CC} down to 0.8V.

Low supply current makes the G696/G697 ideal for use in portable equipment. The G696/G697 are available in 5-pin SOT23-5 packages.

Ordering Information

PART	TEMP. RANGE	PIN-PACKAGE
G696H(L)xxxT1	-40°C ~ +105°C	SOT23-5
G697LxxxT1	-40°C ~ +105°C	SOT23-5

* xxx specifies the threshold voltage.

e.g. 263 denotes the 2.63V threshold voltage.

Pin Configuration

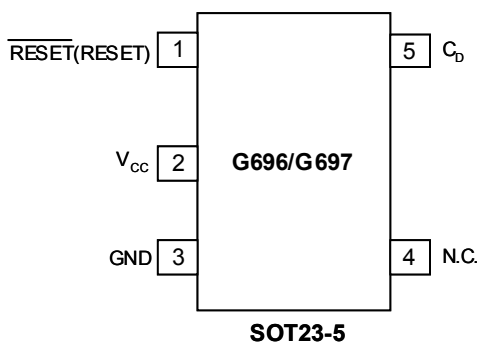

() is for G696H

Typical Operating Circuit

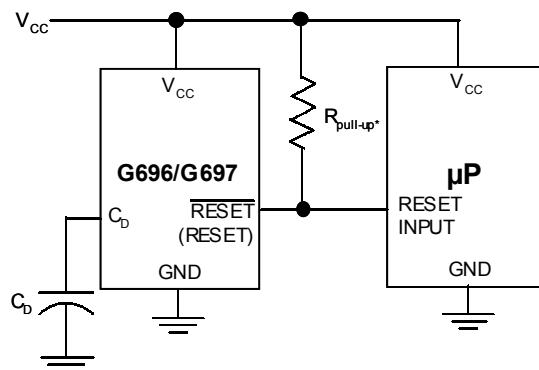

*G697 ONLY



Absolute Maximum Ratings

Terminal Voltage (with respect to GND)
 V_{CC}-0.3V to +6.0V
 Delay Capacitor Pin Voltage, V_{CD}-0.3 to ($V_{CC} + 0.3V$)
 \overline{RESET} , $RESET$ (push-pull).....-0.3V to ($V_{CC} + 0.3V$)
 \overline{RESET} (open drain).....-0.3V to +6.0V
 Input Current, V_{CC} 20mA
 Output Current, $RESET$, \overline{RESET} 20mA

Continuous Power Dissipation ($T_A = +70^\circ C$)
 5-Pin SOT23-5 (derate 2.17mW/ $^\circ C$ above $+70^\circ C$).174mW
 Operating Temperature Range-40 $^\circ C$ to +105 $^\circ C$
 Storage Temperature Range.....-65 $^\circ C$ to +150 $^\circ C$
 Lead Temperature (soldering, 10s).....+300 $^\circ C$

Stresses beyond those listed under “Absolute Maximum Ratings” may cause permanent damage to the device. These are stress ratings only, and functional operation of the device at these or any other conditions beyond those indicated in the operational sections of the specifications is not implied. Exposure to absolute maximum rating conditions for extended periods may affect device reliability.

Electrical Characteristics

(V_{CC} = full range, $T_A = -40^\circ C$ to $+105^\circ C$, unless otherwise noted. Typical values are at $T_A = +25^\circ C$, $V_{CC} = 5V$ for 463/438/400 versions, $V_{CC} = 3.3V$ for 308/293 versions, and $V_{CC} = 3V$ for 263 version.) (Note 1)

PARAMETER	SYMBOL	CONDITION	MIN	TYP	MAX	UNITS
V _{CC} Range		T _A = 0 $^\circ C$ +70 $^\circ C$	0.8		5.5	V
		T _A = -40 $^\circ C$ +105 $^\circ C$	1		5.5	
Supply Current (SOT23-5)	I _{CC}	V _{CC} <5.5V, G69_ 463/438/400/330_		6	10	μA
		V _{CC} <3.6V, G69_ 308/293/263_		5	8.5	
Reset Threshold	V _{TH}	G69_ 463_	4.537	4.63	4.722	V
		G69_ 438_	4.293	4.38	4.467	
		G69_ 400_	3.92	4	4.08	
		G69_ 330_	3.234	3.30	3.366	
		G69_ 308_	3.019	3.08	3.141	
		G69_ 293_	2.872	2.93	2.988	
		G69_ 263_	2.578	2.63	2.682	
Reset Threshold Hysteresis	V _{HYS}	G69_ 463_	139	231	324	mV
		G69_ 438_	132	219	306	
		G69_ 400_	120	200	280	
		G69_ 330_	99	165	231	
		G69_ 308_	93	154	215	
		G69_ 293_	88	146	205	
		G69_ 263_	79	131	184	
Reset Threshold Tempco				70		ppm/ $^\circ C$
C _D Delay Pin Threshold Voltage	V _{TDC}	V _{CC} = 5V G69_ 463/438/400/330_	3	3.3	3.9	V
		V _{CC} =3.3V G69_ 308/293	1.9	2.3	2.7	
		V _{CC} =3.0V G69_ 263_	1.8	2.2	2.6	
Delay Capacitor Pin Sink Current	I _{CD}	V _{CC} = 1.5V, V _{CD} = 0.5V	3	5		mA
Delay Pull up Resistance	R _D		1	1.5	2.3	M Ω

**Electrical Characteristics (Continued)**

(V_{CC} = full range, T_A = -40°C to $+105^{\circ}\text{C}$, unless otherwise noted. Typical values are at T_A = $+25^{\circ}\text{C}$, V_{CC} = 5V for 463/438/400/330 versions, V_{CC} = 3.3V for 308/293 versions, and V_{CC} = 3V for 263 version.) (Note 1)

PARAMETER	SYMBOL	CONDITION	MIN	TYP	MAX	UNITS
RESET Output Current Low (push-pull active low, and open-drain active-low, G696L and G697L)	I_{OL}	$V_{CC} = 2.5\text{V}$, $V_{\overline{\text{RESET}}} = 0.5\text{V}$	8			mA
RESET Output Current High (push-pull active low, G696L)	I_{OH}	$V_{CC} = 5\text{V}$, $V_{\overline{\text{RESET}}} = 4.5\text{V}$, G696L463/438/400/330	4.5			mA
		$V_{CC} = 3.3\text{V}$, $V_{\overline{\text{RESET}}} = 2.8\text{V}$, G696L308/293	3			
		$V_{CC} = 3\text{V}$, $V_{\overline{\text{RESET}}} = 2.5\text{V}$, G696L263	2			
RESET Output Current Low (push-pull active high, G696H)	I_{OL}	$V_{CC} = 5\text{V}$, $V_{\overline{\text{RESET}}} = 0.5\text{V}$, G696H463/438/400/330	16			mA
		$V_{CC} = 3.3\text{V}$, $V_{\overline{\text{RESET}}} = 0.5\text{V}$, G696H308/293	12			
		$V_{CC} = 3\text{V}$, $V_{\overline{\text{RESET}}} = 0.5\text{V}$, G696H263	10			
RESET Output Current High (push-pull active high, G696H)	I_{OH}	$V_{CC} = 2.5\text{V}$, $V_{\overline{\text{RESET}}} = 2\text{V}$	2			mA
RESET Open-Drain Output Leakage Current (G697L)		$V_{CC} > V_{TH}$, $\overline{\text{RESET}}$ deasserted			1	μA

Note 1: Production testing done at T_A = $+25^{\circ}\text{C}$; limits over temperature guaranteed by design.

Selector Guide

PART/SUFFIX	RESET THRESHOLD (V)	OUTPUT TYPE	TOP MARK
G697L463T_	4.63	Open-Drain $\overline{\text{RESET}}$	697Gx
G697L438T_	4.38	Open-Drain $\overline{\text{RESET}}$	697Fx
G697L400T_	4.00	Open-Drain $\overline{\text{RESET}}$	697Ex
G697L330T_	3.30	Open-Drain $\overline{\text{RESET}}$	697Dx
G697L308T_	3.08	Open-Drain $\overline{\text{RESET}}$	697Cx
G697L293T_	2.93	Open-Drain $\overline{\text{RESET}}$	697Bx
G697L263T_	2.63	Open-Drain $\overline{\text{RESET}}$	697Ax
G696H463T_	4.63	Push-Pull RESET	696Lx
G696H438T_	4.38	Push-Pull RESET	696Kx
G696H400T_	4.00	Push-Pull RESET	696Jx
G696H330T_	3.30	Push-Pull RESET	696Nx
G696H308T_	3.08	Push-Pull RESET	696Ix
G696H293T_	2.93	Push-Pull RESET	696Hx
G696H263T_	2.63	Push-Pull RESET	696Gx
G696L463T_	4.63	Push-Pull $\overline{\text{RESET}}$	696Fx
G696L438T_	4.38	Push-Pull $\overline{\text{RESET}}$	696Ex
G696L400T_	4.00	Push-Pull $\overline{\text{RESET}}$	696Dx
G696L330T_	3.30	Push-Pull $\overline{\text{RESET}}$	696Mx
G696L308T_	3.08	Push-Pull $\overline{\text{RESET}}$	696Cx
G696L293T_	2.93	Push-Pull $\overline{\text{RESET}}$	696Bx
G696L263T_	2.63	Push-Pull $\overline{\text{RESET}}$	696Ax



Typical Operating Characteristics

(V_{CC} = full range, T_A = -40°C to +105°C, unless otherwise noted. Typical values are at T_A = +25°C, V_{CC} = 5V for 463/438/400/330 versions, V_{CC} = 3.3V for 308/293 versions, and V_{CC} = 3V for 263 version.)

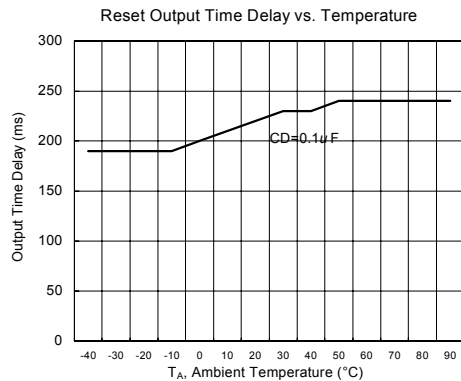
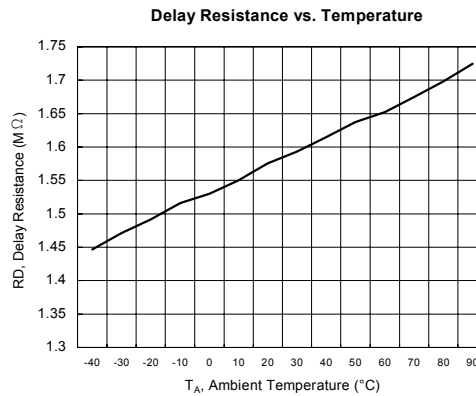
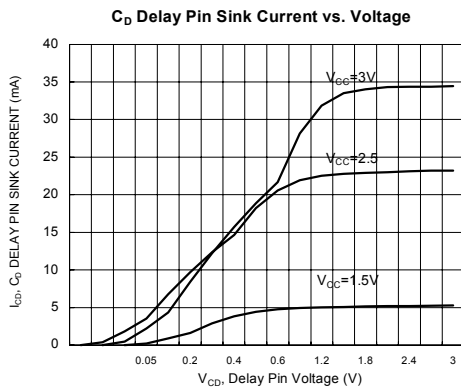
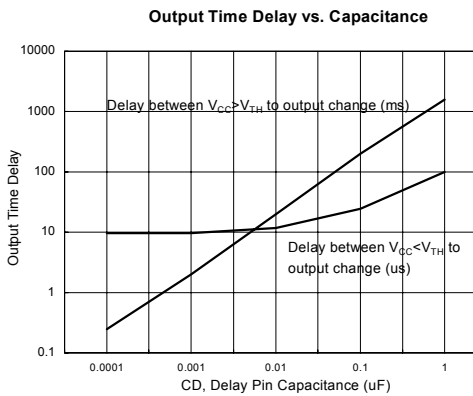
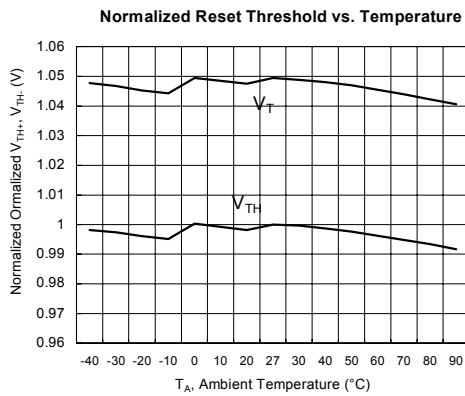
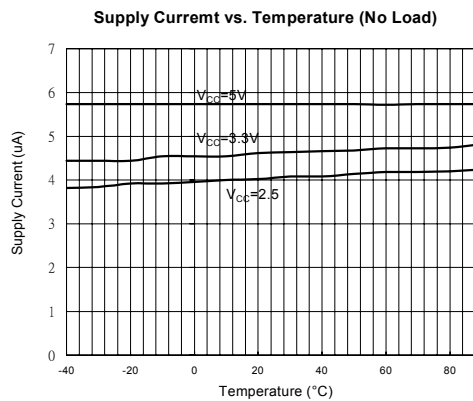
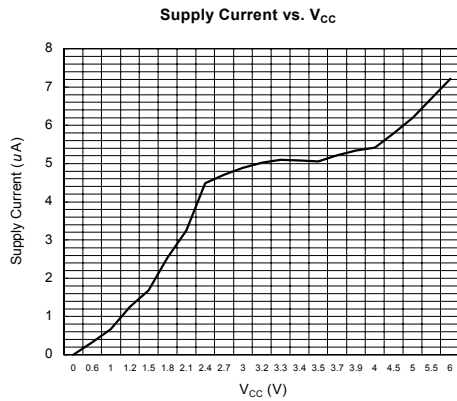

Timing Diagram

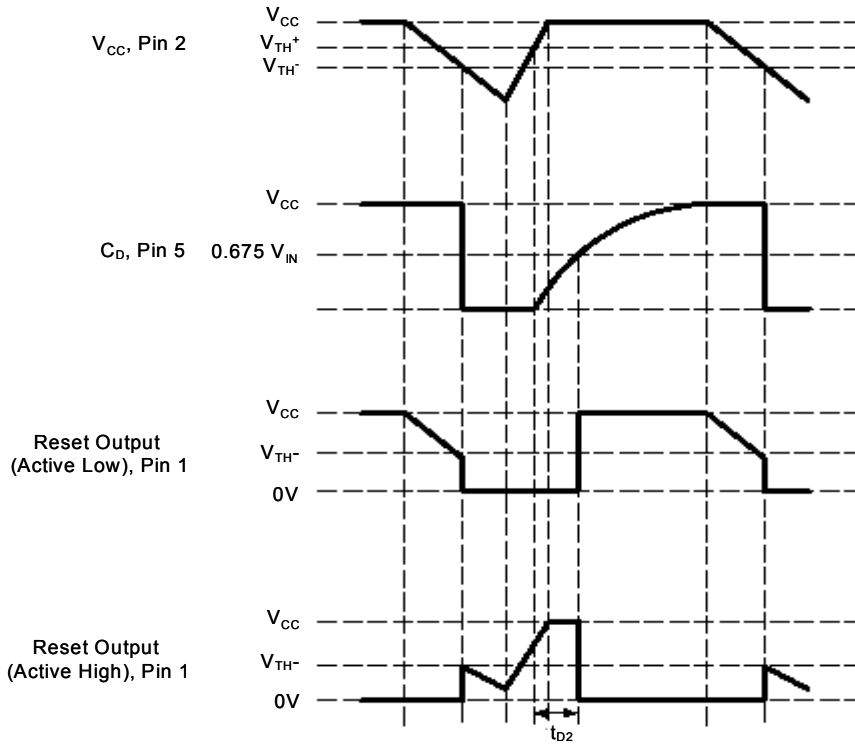

Figure 1

Functional Diagram

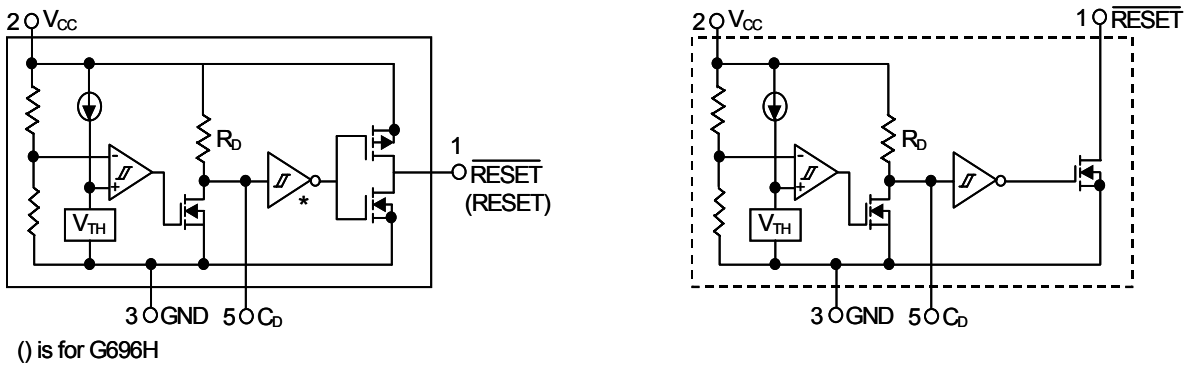

Figure 2

Pin Description

PIN	NAME	FUNCTION
1	$\overline{\text{RESET}}$ (G696L/G697L)	RESET Output remains low while V_{CC} is below the reset threshold, and for delay time set by C_D after V_{CC} rises above the reset threshold.
	RESET (G696H)	RESET Output remains high while V_{CC} is below the reset threshold, and for delay time set by C_D after V_{CC} rises above the reset threshold.
2	V_{CC}	Supply Voltage (+5V, +3.3V, +3.0V)
3	GND	Ground
4	N.C.	No Connection.
5	C_D	External Programmable time delay is set by the capacitor connect to C_D pin.

Detailed Description

A microprocessor's (μP 's) reset input starts the μP in a known state. The G697L/G696L/G696H assert reset to prevent code-execution errors during power-up, power-down, or brownout conditions. They assert a reset signal whenever the V_{CC} supply voltage declines below a preset threshold (V_{TH-}), keeping it asserted for time delay set by capacitor connected to C_D pin, after V_{CC} has risen above the high reset threshold V_{TH+} ($V_{TH+} + V_{HYS}$). The G697L uses an open-drain output, and the G696L/G696H have a push-pull output stage. Connect a pull-up resistor on the G697L's $\overline{\text{RESET}}$ output to any supply between 0 and 5.5V.

The time delay is set by external capacitor C_D , and internal pull up resistor R_D . When the voltage at C_D pin exceeds the buffer threshold, typically $0.675 V_{CC}$, the $\overline{\text{RESET}}$ output high (RESET output low). The voltage detector and buffer have built-in hysteresis to prevent erratic reset operation. The formula of time delay is $T \text{ (ms)} \approx 1685 C_D \text{ (\mu F)}$. Fig1 and Fig2 show a timing diagram and a Functional Block.

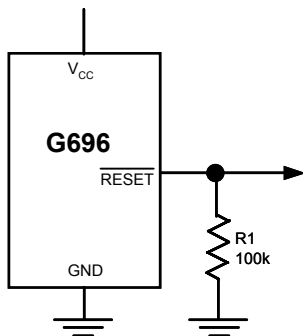

Figure 3. $\overline{\text{RESET}}$ Valid to $V_{CC} = \text{Ground}$ Circuit

Ensuring a Valid Reset Output Down to $V_{CC} = 0$

When V_{CC} falls below 0.8V, the G696 $\overline{\text{RESET}}$ output no longer sinks current—it becomes an open circuit. Therefore, high-impedance CMOS logic inputs connected to $\overline{\text{RESET}}$ can drift to undetermined voltages. This presents no problem in most applications since most μP and other circuitry is inoperative with V_{CC} below 0.8V. However, in applications where $\overline{\text{RESET}}$

must be valid down to 0V, adding a pull-down resistor to $\overline{\text{RESET}}$ causes any stray leakage currents to flow to ground, holding $\overline{\text{RESET}}$ low (Figure 4). R_1 's value is not critical; 100k Ω is large enough not to load $\overline{\text{RESET}}$ and small enough to pull $\overline{\text{RESET}}$ to ground.

A 100k Ω pull-up resistor to V_{CC} is also recommended for the G697L if $\overline{\text{RESET}}$ is required to remain valid for $V_{CC} < 0.8V$.

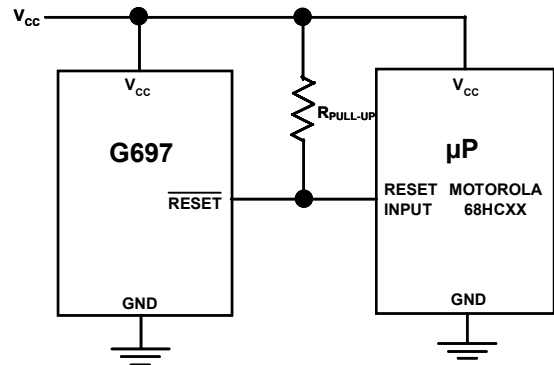

Figure 4. Interfacing to μP s with Bidirectional Reset I/O

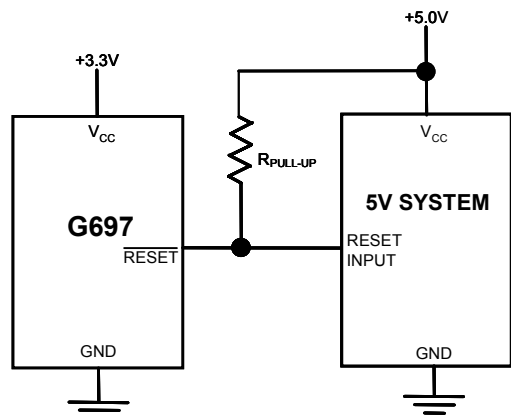

Figure 5. G697L Open-Drain $\overline{\text{RESET}}$ Output Allows Use with Multiple Supplies

**Interfacing to μ Ps with Bidirectional Reset Pins**

Since the $\overline{\text{RESET}}$ output on the G697L is open drain, this device interfaces easily with μ Ps that have bidirectional reset pins, such as the Motorola 68HC11. Connecting the μ P supervisor's $\overline{\text{RESET}}$ output directly to the microcontroller's (μ C's) $\overline{\text{RESET}}$ pin with a single pull-up resistor allows either device to assert reset (Figure 5).

G697L Open-Drain $\overline{\text{RESET}}$ Output Allows Use with Multiple Supplies

Generally, the pull-up connected to the G697L will connect to the supply voltage that is being monitored at the IC's V_{CC} pin. However, some systems may use the open-drain output to level-shift from the monitored supply to reset circuitry powered by some other supply (Figure 6). Note that as the G697L's V_{CC} decreases below 1V, so does the IC's ability to sink current at $\overline{\text{RESET}}$. Also, with any pull-up, $\overline{\text{RESET}}$ will be pulled

high as V_{CC} decays toward 0. The voltage where this occurs depends on the pull-up resistor value and the voltage to which it is connected.

Benefits of Highly Accurate Reset Threshold

Most μ P supervisor ICs have reset threshold voltages between 5% and 10% below the value of nominal supply voltages. This ensures a reset will not occur within 5% of the nominal supply, but will occur when the supply is 10% below nominal.

When using ICs rated at only the nominal supply $\pm 5\%$, this leaves a zone of uncertainty where the supply is between 5% and 10% low, and where the reset may or may not be asserted.

The G69__463/G69__308 use highly accurate circuitry to ensure that reset is asserted close to the 5% limit, and long before the supply has declined to 10% below nominal.

Package Information

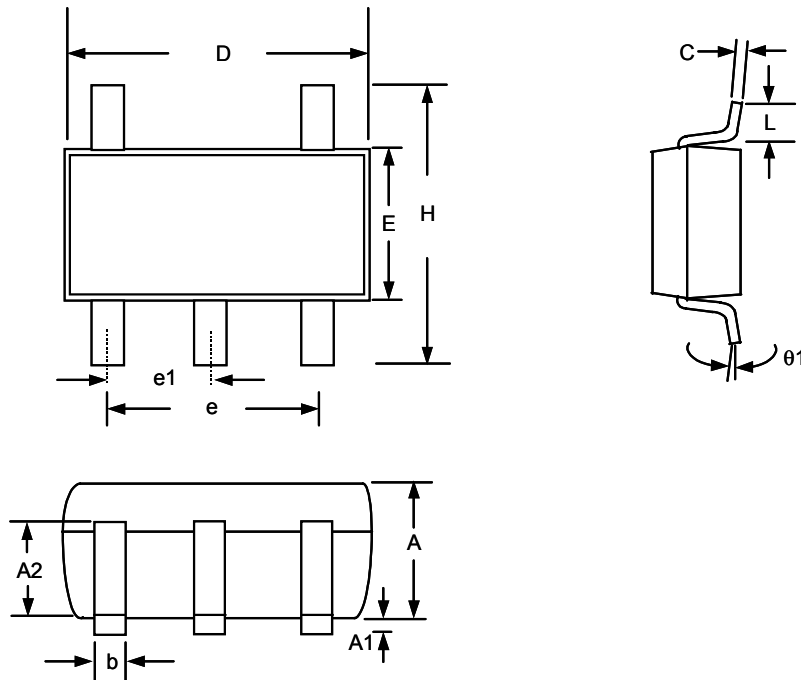

Note:

1. Package body sizes exclude mold flash protrusions or gate burrs
2. Tolerance ± 0.1000 mm (4mil) unless otherwise specified
3. Coplanarity: 0.1000mm
4. Dimension L is measured in gage plane

SYMBOLS	DIMENSIONS IN MILLIMETERS		
	MIN	NOM	MAX
A	1.00	1.10	1.30
A1	0.00	----	0.10
A2	0.70	0.80	0.90
b	0.35	0.40	0.50
C	0.10	0.15	0.25
D	2.70	2.90	3.10
E	1.40	1.60	1.80
e	----	1.90(TYP)	----
e1	----	0.95	----
H	2.60	2.80	3.00
L	0.37	----	----
$\theta 1$	1°	5°	9°

Taping Specification

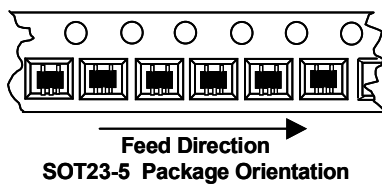

GMT Inc. does not assume any responsibility for use of any circuitry described, no circuit patent licenses are implied and GMT Inc. reserves the right at any time without notice to change said circuitry and specifications.