

Low-Dropout, 300mA Linear Regulator with Reset

Features

- 300mA Output Current, with Foldback Current Limiting
- High Ripple Rejection
- $\pm 1.5\%$ Output Accuracy
- $\pm 2\%$ Reset Threshold Accuracy
- Externally Programmable Reset Time Delay Generator
- Internal 300mA P-Channel Pass Transistor
- 320 μ A quiescent Current
- Thermal Overload Protection
- SOP 8 Package

Applications

- CD ROM or DVD ROM
- Slim-Type CD/DVD
- DVD Player

General Description

The G9611 are low-dropout, linear regulator with reset function supply 3.4V, 3.3V or 2.5V output for currents up to 300mA. They are available in a 700mW SOP 8 package. Typical dropouts are 320mV at 300mA. Shutdown turns off linear regulator function. Other features include foldback current limiting and thermal overload protection.

The reset function in G9611 detect V_{CC} level with hysteresis, keeping it asserted for time delay determined by external capacitor. The reset output is active low open-drain output. The detection threshold are 3.9V or 4.2V.

The output is preset at 3.4V for the G9611A, 3.3V for the G9611B/C, and 2.5V for G9611D. The reset threshold is preset at 4.2V for G9611 A/B/D and 3.9V for G9611C.

Ordering Information

PART NUMBER	MARKING	REGULATOR OUTPUT VOLTAGE	RESET THRESHOLD VOLTAGE	TEMP. RANGE	PIN-PACKAGE
G9611AP1x	G9611A	3.4	4.2	-40°C to +85°C	SOP 8L
G9611BP1x	G9611B	3.3	4.2	-40°C to +85°C	SOP 8L
G9611CP1x	G9611C	3.3	3.9	-40°C to +85°C	SOP 8L
G9611DP1x	G9611D	2.5	4.2	-40°C to +85°C	SOP 8L

Note: X Specify the packing type
 U: Tape & Reel T: Tube

Pin configuration

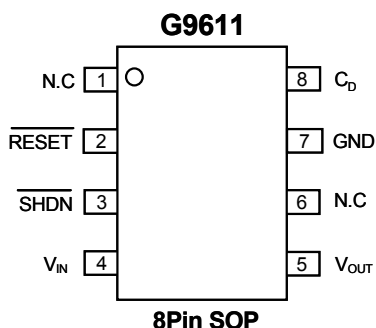

Typical Operation Circuit

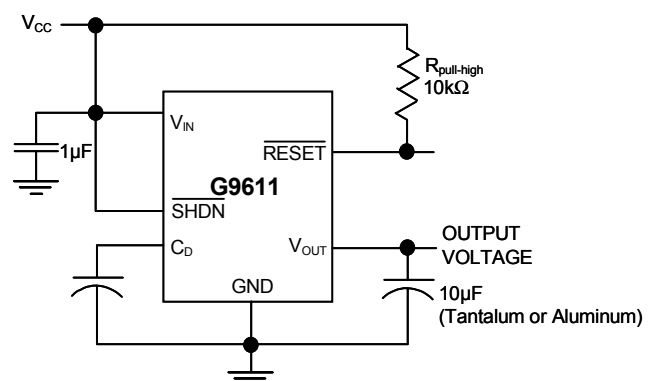

**Absolute Maximum Ratings**

Supply Voltage (IN or OUT to GND).....-0.3V to +6.5V
 Output Short-Circuit Duration.....1 min
 Input Voltage-0.3V to the greater of
 (IN+0.3V) or (OUT + 0.3V)
 Continuous Power Dissipation (T_A = +25°C).....700mW

Operating Temperature Range..... -40°C to +85°C
 Junction Temperature.....+160°C
 Storage Temperature Range.....-65°C to +160°C
 Lead Temperature (soldering, 10sec).....+300°C

Stresses beyond those listed under "Absolute Maximum Ratings" may cause permanent damage to the device. These are stress ratings only, and functional operation of the device at these or any other conditions beyond those indicated in the operational sections of the specifications is not implied. Exposure to absolute maximum rating conditions for extended periods may affect device reliability

Electrical Characteristics

V_{IN}=5V, C_{IN}=1μF, C_{OUT}=10μF, $\overline{\text{SHDN}}=V_{\text{IN}}$, T_J=T_A=25°C (Note3), unless otherwise noted. Typical values for regulators are at V_{IN} =5V.

PARAMETER	SYMBOL	CONDITIONS	MIN	TYP	MAX	UNITS
Input Voltage	V _{IN}		2.5		6.0	V
Output Voltage (Note 1)	V _{OUT}	G9611A	3.35	3.4	3.45	V
		G9611B/C	3.25	3.3	3.35	
		G9611D	2.45	2.5	2.55	
Load Regulation	ΔV _{LDR}	I _{OUT} =1mA to 300mA, V _{IN} =V _{OUT} +1V		6	15	mV
Line Regulation	ΔV _{LNR}	(V _{OUT} +0.5V) ≤ V _{IN} ≤ 6V, I _{OUT} =25mA	-8	0.3	8	mV
Dropout Voltage (Note 2)	ΔV _{DO}	I _{OUT} =300mA		320	400	mV
Parameter Tempco V _{OUT}				40		ppm/°C
Ripple Rejection	PSRR	f=120HZ, I _{OUT} =30mA		70		dB
		f=120HZ, I _{OUT} =300mA		65		
Output Noise	e _n	20Hz to 100kHz, I _{OUT} =30mA.		350		μV _{RMS}
Quiescent Current	I _Q			320	450	μA
OFF Quiescent Current	I _{QOFF}	$\overline{\text{SHDN}} \leq 0.4V$		140	200	μA
Foldback Current Limit	I _{LIM}	V _{OUT} <V _{FOLDBACK}	260	400	580	mA
		V _{OUT} >V _{FOLDBACK}	650	900	1200	
Foldback Voltage	V _{FOLDBACK}		0.6	0.78	0.95	V
Thermal Shutdown Temperature	T _{SD}			160		°C
Thermal Shutdown Hysteresis	ΔT _{SD}			30		°C
SHDN Pin Input High Threshold	V _{IH_SHDN}		1.8	2	2.3	V
SHDN Pin Input Low Threshold	V _{IL_SHDN}		0.6	0.8	1.1	V
Reset Threshold	V _{TH}	G9611A/B/D	4.11	4.2	4.29	V
		G9611C	3.81	3.9	3.99	
Reset Threshold Hysteresis	V _{HYS}	G9611A/B/D		150		mV
		G9611C		130		
Reset Threshold Tempco				40		ppm/°C
C _D Delay Pin Threshold Voltage	V _{TCD}	V _{CC} = 5V	3.5	3.9	4.3	V
C _D Pin Sink Current	I _{CD}	V _{CC} =1.5V, V _{CD} =0.5V	3	4.3		mA
C _D Pin Pullup Resistance	R _D		100	200	400	kΩ
RESET Output Current Low	I _{OL}	V _{CC} =2.5V, V _{RESET} =0.4V	8	11.5		mA
RESET Function Operating Voltage	V _{OP}	$\overline{\text{RESET}}$ sink current>10μA		0.7	0.85	V

Note 1: (V_{IN}-V_{OUT}) is limited to keep the product (I_{OUT} x (V_{IN} - V_{OUT})) from exceeding the package power dissipation limits.

Note 2: Dropout Voltage is (V_{IN} - V_{OUT}) when V_{OUT} falls to 100mV below its nominal value at V_{IN} = V_{OUT}+1V. For example, the G9611 is tested by measuring the V_{OUT} at V_{IN} = V_{OUT}+1V, then V_{IN} is lowered until V_{OUT} falls 100mV below the measured value. The difference (V_{IN} - V_{OUT}) is then measured and defined as ΔV_{DO}.

Note 3: Low duty pulse techniques are used during test to maintain junction temperature as close to ambient as possible.



Typical Performance Characteristics

($V_{IN}=5V, C_{IN}=C_{OUT}=10\mu F, \overline{SHDN}=V_{IN}, T_J=25^\circ C$, unless otherwise noted)

SHDN Pin vs. Output

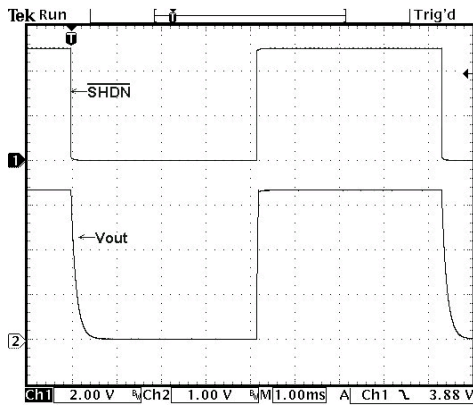

Load transient

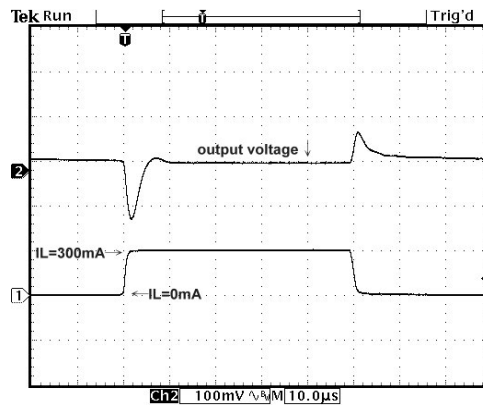

Line Transient

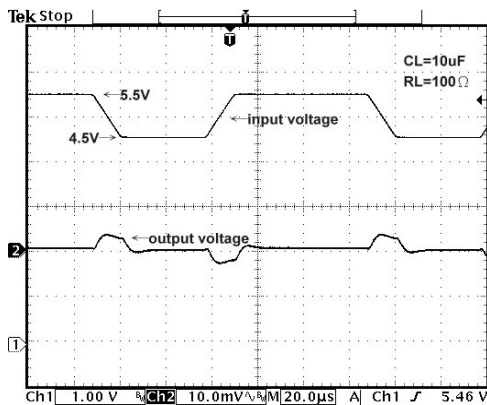

Line Transient

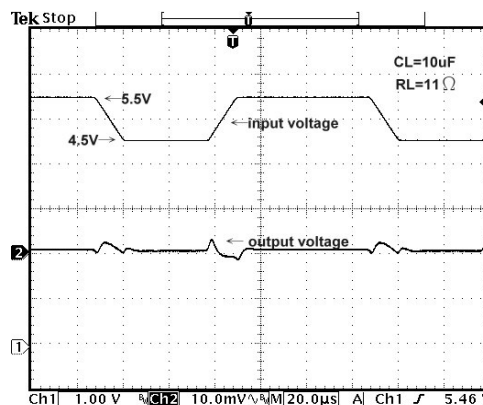

Over Current Response

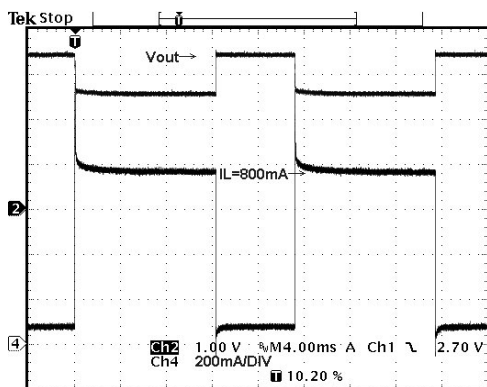

Short Circuit Response

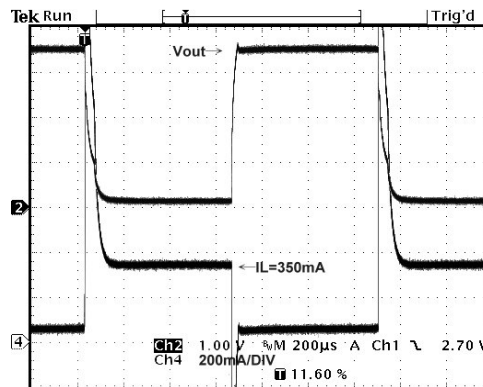



Typical Performance Characteristics (continued)

Power Supply Rejection Ratio

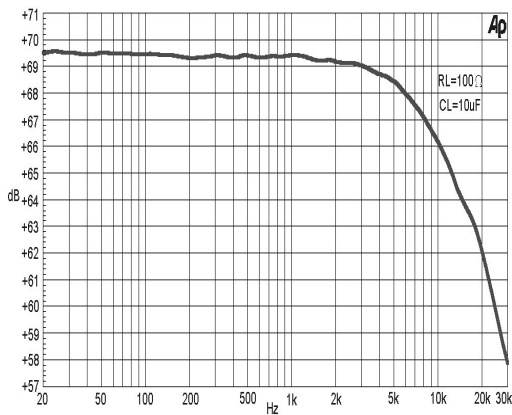

Power Supply Rejection Ratio

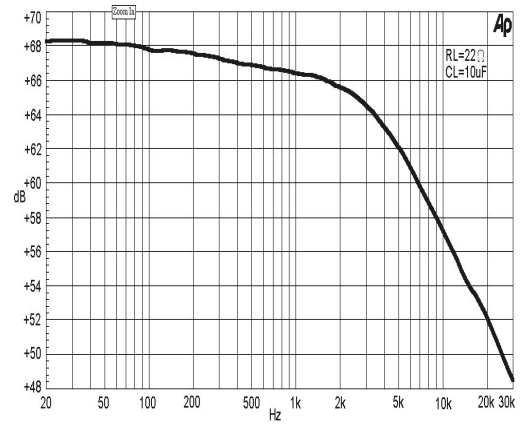

Power Supply Rejection Ratio

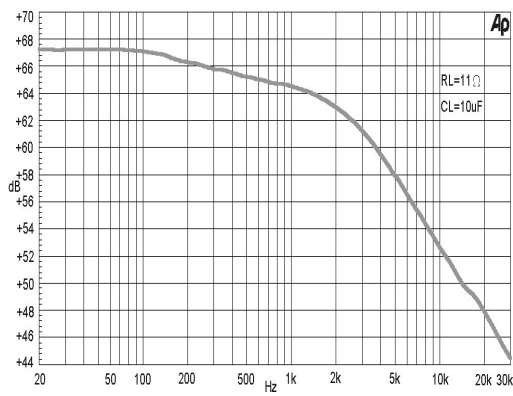

Safe Operating Area of G9611 SO-8

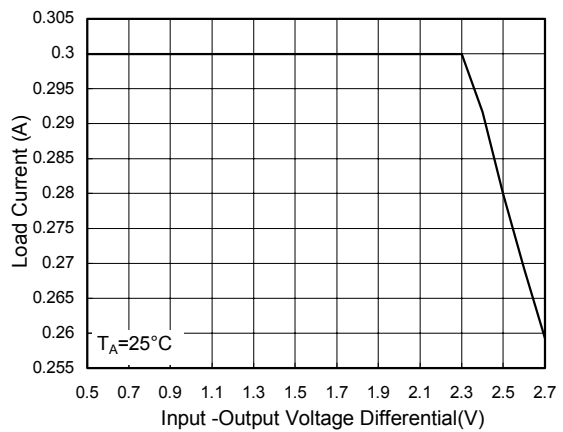

Pin Description

PIN NO.	PIN NAME	PIN FUNCTION
1, 6	N.C	No Connection.
2	$\overline{\text{RESET}}$	$\overline{\text{RESET}}$ Open-Drain Output remains low while V_{IN} is below the reset threshold, and for delay time set by C_{D} after V_{IN} rises above the reset threshold.
3	$\overline{\text{SHDN}}$	$\overline{\text{SHDN}}$ = High to enable regulator output. $\overline{\text{SHDN}}$ = Low to shutdown regulator output.
4	V_{IN}	Regulator Input. Supply voltage can range from 2.5V to 6V.
5	V_{OUT}	Regulator Output. Sources up to 300mA.
7	GND	Ground
8	C_{D}	External Programmable time delay is set by the capacitor connect to C_{D} pin.

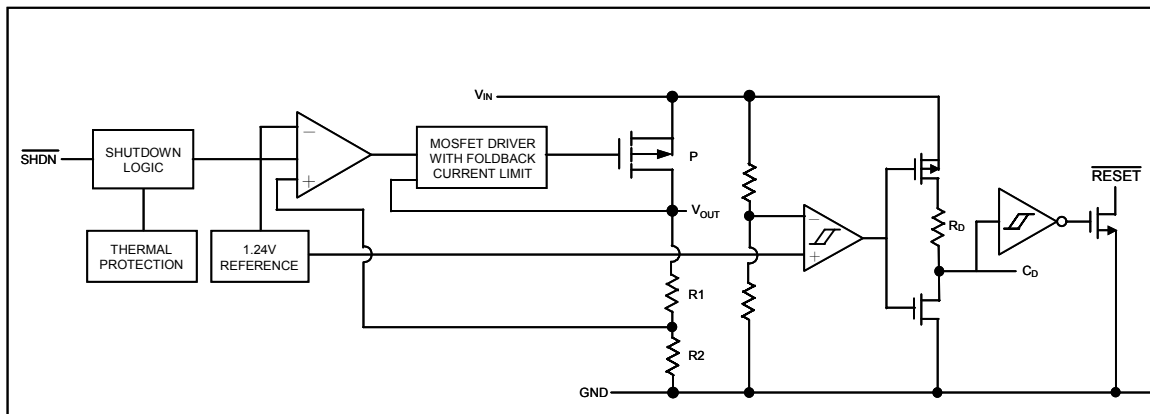

Figure 1. Functional Diagram

Detailed Description

The G9611 are low-dropout, low-quiescent current linear regulators with reset function. The regulator in G9611 supply 3.4V, 3.3V or 2.5V output for load currents up to 300mA. The reset function detect V_{IN} . As illustrated in Figure 1, they consist of a 1.24V reference, error amplifier, MOSFET driver, P-channel pass transistor, and internal feedback voltage divider, reset threshold comparator and time delay generator.

The 1.24V bandgap reference is connected to the error amplifier's inverting input. The error amplifier compares this reference with the feedback voltage and amplifies the difference. The MOSFET driver reads the error signal and applies the appropriate drive to the P-channel pass transistor. If the feedback voltage is lower than the reference, the pass transistor gate is pulled lower, allowing more current to pass and increasing the output voltage. If the feedback voltage is too high, the pass transistor gate is pulled up, allowing less current to pass to the output.

Additional blocks of linear regulator include a foldback current limiter, thermal sensor, and shutdown logic.

The G9611 also offer reset function to detect the level of V_{IN} . They assert a reset signal whenever V_{IN} supply voltage declines below a preset threshold (V_{TH}), keeping it asserted for time delay set by capacitor connected to C_{D} pin, after V_{IN} has risen above the high reset threshold ($V_{\text{TH}} + V_{\text{HYS}}$). The $\overline{\text{RESET}}$ is an active low, open-drain output.

Internal P-Channel Pass Transistor

The G9611 feature a 300mA P-channel MOSFET pass transistor. This provides several advantages over similar designs using PNP pass transistors, including longer battery life. The P-channel MOSFET requires no base drive, which reduces quiescent current considerably. PNP based regulators waste considerable amounts of current in dropout when the pass transistor saturates. They also use high base-drive currents under large loads. The G9611 do not suffer from these problems and consume only 320 μA of quiescent current.

**Shutdown**

A low input on the $\overline{\text{SHDN}}$ pin shuts down the G9611. In the off mode, the pass transistor, regulator control circuit are turned off, Only reset function is turned on, reducing the supply current below 140 μA . $\overline{\text{SHDN}}$ should be connected to V_{IN} for normal operation. Use a fast comparator, Schmitt trigger, or CMOS or TTL Logic to drive the $\overline{\text{SHDN}}$ pin in and out of shutdown. Rise times should be shorter than 1 μs . Do not use slow RC circuits, leave $\overline{\text{SHDN}}$ open, or allow the input to linger between thresholds.

Foldback Current Limiting

The G9611 also include a foldback current limiter. It monitors and controls the pass transistor's gate voltage, estimating the output current and limiting it to 900mA for output voltages above 0.78V. If the output voltage drops below 0.78V, implying a short-circuit condition, the output current is limited to 400mA.

Thermal Overload Protection

Thermal overload protection limits total power dissipation in the G9611. When the junction temperature exceeds $T_J = +160^\circ\text{C}$, the thermal sensor sends a signal to the shutdown logic, turning off the pass transistor and allowing the IC to cool. The thermal sensor will turn the pass transistor on again after the IC's junction temperature cools by 30°C , resulting in a pulsed output during thermal overload conditions.

Thermal overload protection is designed to protect the G9611 in the event of fault conditions. For continual operation, the absolute maximum junction temperature rating of $T_J = +160^\circ\text{C}$ should not be exceeded.

Operating Region and Power Dissipation

Maximum power dissipation of the G9611 depends on the thermal resistance of the case and circuit board, the temperature difference between the die junction and ambient air, and the rate of air flow. The power dissipation across the device is $P = I_{\text{OUT}} (V_{\text{IN}} - V_{\text{OUT}})$. The resulting maximum power dissipation is:

$$P_{\text{MAX}} = \left[\frac{(T_J - T_A)}{(\theta_{\text{JC}} + \theta_{\text{CA}})} \right]$$

where $(T_J - T_A)$ is the temperature difference between the G9611 die junction and the surrounding air, θ_{JC} is the thermal resistance of the package chosen, and θ_{CA} is the thermal resistance through the printed circuit board, copper traces and other materials to the sur-

rounding air. The thermal resistance of SOP-8 is $\theta_{\text{JC}} = 192^\circ\text{C/W}$.

The power dissipation of G9611 is:

$$P_D = (V_{\text{IN}} - V_{\text{OUT}}) \times I_{\text{OUT}}$$

The worst-case thermal resistance from case to air (θ_{CA}) requirements are:

$$\theta_{\text{CA}} = \frac{(125^\circ\text{C} - T_A)}{P_D}$$

Use larger copper pad area to obtain specific heat sink thermal resistance values for larger output current, higher input-output difference, and higher ambient temperature.

C_D Capacitor Selection

The reset timeout delay is set by internally pull-up R_D (typical value 200k Ω) and external C_D .

When the voltage at C_D pin exceeds the buffer threshold, typically $0.85 V_{\text{CC}}$, the $\overline{\text{RESET}}$ output high. The voltage detector and buffer have built-in hysteresis to prevent erratic reset operation. For $C_D = 0.1\mu\text{F}$, typical reset time delay is 10ms.

Regulator Output Capacitor Selection and Regulator Stability

Normally, use capacitors 0.1 μF minimum on the input and 10 μF minimum on the output of the G9611. The larger input capacitor values provide better supply noise rejection and line-transient response. Improve load transient response, stability, and power-supply rejection by using large output capacitors. For stable operation over the full temperature range and with load current up to 300mA, 10 μF tantalum or 47 μF aluminum minimum is recommended. Too small capacitors with small ESR can result in oscillation.

Transient Considerations

The Typical Operating Characteristics show the G9611 load-transient response. Two components of the output response can be observed on the load-transient graphs—a DC shift from the output impedance due to the different load currents, and the transient response. Typical transients for step changes in the load current from 5mA to 500mA are 0.1V. Increasing the output capacitor's value attenuates transient spikes.

Package Information

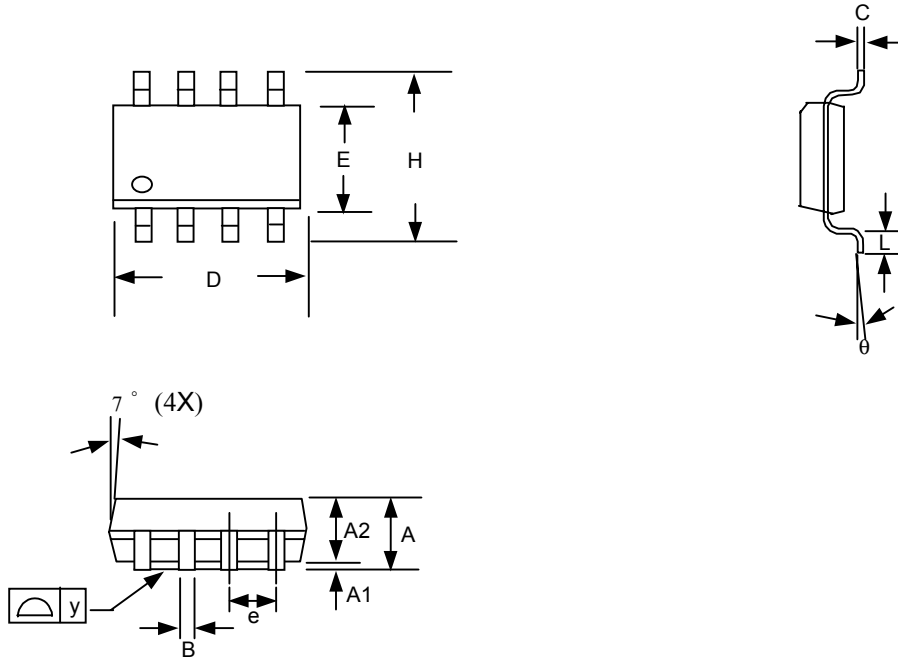

Note:

1. Package body sizes exclude mold flash and gate burrs
2. Dimension L is measured in gage plane
3. Tolerance 0.10mm unless otherwise specified
4. Controlling dimension is millimeter converted inch dimensions are not necessarily exact.

SYMBOL	DIMENSION IN MM			DIMENSION IN INCH		
	MIN.	NOM.	MAX.	MIN.	NOM.	MAX.
A	1.35	1.60	1.75	0.053	0.063	0.069
A1	0.10	----	0.25	0.004	----	0.010
A2	----	1.45	----	----	0.057	----
B	0.33	----	0.51	0.013	----	0.020
C	0.19	----	0.25	0.007	----	0.010
D	4.80	----	5.00	0.189	----	0.197
E	3.80	----	4.00	0.150	----	0.157
e	----	1.27	----	----	0.050	----
H	5.80	----	6.20	0.228	----	0.244
L	0.40	----	1.27	0.016	----	0.050
y	----	----	0.10	----	----	0.004
θ	0°	----	8°	0°	----	8°

Taping Specification

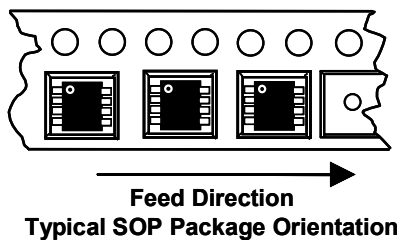

GMT Inc. does not assume any responsibility for use of any circuitry described, no circuit patent licenses are implied and GMT Inc. reserves the right at any time without notice to change said circuitry and specifications.