

# GC89...R

## BAR CLAMP FOR HOCKEY PUK DEVICES

Clamping total thickness of assembly from  
11mm to 119mm

Pre-loaded to the specific clamping  
force (12 ÷ 24 kN)

Maximum device diameter: 76mm

Surface passivation to provide extra protection

Hexagon head bolt partially

threaded M8x1.25, UNI5737, 8.8 steel

Various lengths of bolts and insulators

Round shaped clamping head for optimal clamping  
force application

Four styles available

User friendly clamping force indicator

UL94 certified insulation material

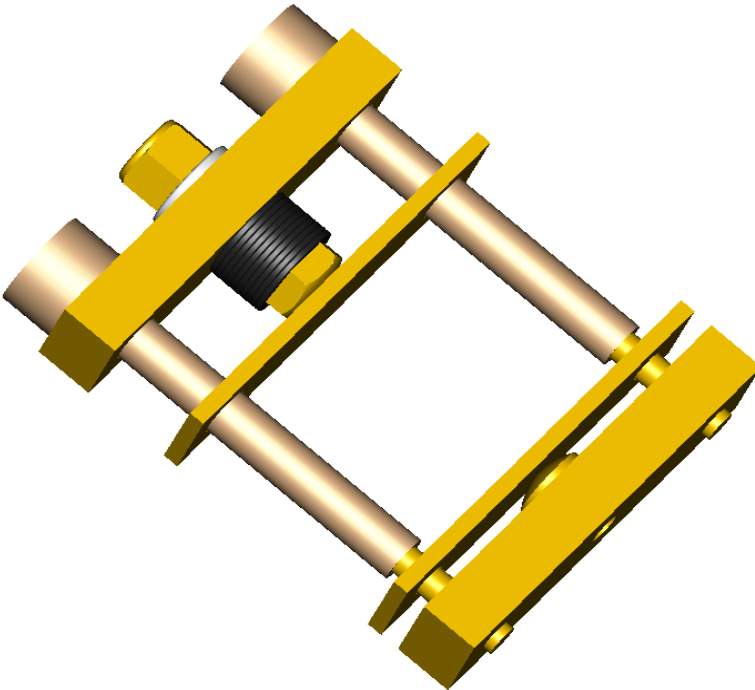

Parameter	Unit	Types	Testing conditions	Notes	Values			
					Min	Typ	Max	
Weight	g	GC89S...R			730		860	
		GC89B...R			1120		1290	
Clamping Force*	kN	GC89...12R				12		
		GC89...16R				16		
		GC89...20R					20	
		GC89...24R					24	
Clamping Force tolerance						± 10%		
Insulation Voltage	V <sub>RMS</sub>		1 min			3000		
Insulating Material				Noryl ® **				
UL File				E121562				
Max. working temperature	°C				-30		110	
Creepage distance:	mm					28		
Clearance distance:	mm					20.3		
Storage temperature	°C				-40		110	
Flammability	mm			UL94 V-1 Flame class rating		1.5		
	mm			UL94 V-0 Flame class rating		8.00		
	mm			CSA Flammability		1.00		

\* Other clamping forces available: contact factory

\*\* Noryl ® is a registered trade mark of General Electric



**ORDERING INFORMATION TABLE**

Clamps can be ordered using the following part numbering system

<b>GC89</b>	<b>B</b>	<b>N</b>	<b>B</b>	<b>A</b>	<b>20</b>	<b>R</b>	<b>S</b>
(1)	(2)	(3)	(4)	(5)	(6)		

<b>(1) Construction type:</b>	B = with double bar S = with single bar
<b>(2) Insulator position:</b>	N = upper side R = lower side
<b>(3) Insulator code:</b>	see table below
<b>(4) Bolt code:</b>	see table below
<b>(5) Clamping force (in kN):</b>	12 16 20 24
<b>(6) Special accessories</b>	blank = no accessories S = extra bar spacer D = pressure disc in place of pressure bar

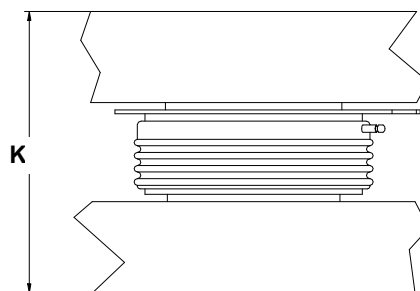

K: Total thickness of the assembly to be clamped

 For thicknesses  $S'_{Min} < K < S_{Min}$  an additional 4mm thick bar spacer is needed (see list of special accessories)

**Type GC89BN...R: suggested insulator/bolt types**

Allowed clearance S			Insulator choice		Bolt choice		Max height
S' Min [mm]**	S Min [mm]	S Max [mm]	(3)	Ins. Length [mm]	(4)	Bolt Length [mm]	T [mm]
11	15	30	A	50	Z	100	115
21	25	40	A	50	A	110	125
31	35	50	B	70	B	120	135
41	45	60	B	70	C	130	145
51	55	70	C	95	D	140	155
61	65	80	C	95	E	150	165
71	75	90	C	95	F	160	175

\*\* with additional bar spacer only

**Type GC89BR...R: suggested insulator/bolt types**

Allowed clearance S			Insulator choice		Bolt choice		Max height
S' Min [mm]**	S Min [mm]	S Max [mm]	(3)	Ins. Length [mm]	(4)	Bolt Length [mm]	T [mm]
11	15	30	A	50 ***	Z	100	129
21	25	40	A	50	A	110	139
31	35	50	A	50	B	120	149
41	45	60	B	70	C	130	159
51	55	70	B	70	D	140	169
61	65	80	B	70	E	150	179
71	75	90	C	95	F	160	189

\*\* with additional bar spacer only

 \*\*\* For S<sub>Max</sub>
**Type GC89SN...R: suggested insulator/bolt types**

Allowed clearance S			Insulator choice		Bolt choice		Max height
S' Min [mm]**	S Min [mm]	S Max [mm]	(3)	Ins. Length [mm]	(4)	Bolt Length [mm]	T [mm]
20	24	39	A	50	Z	100	110
30	34	49	B	70	A	110	120
40	44	59	B	70	B	120	130
50	54	69	C	95	C	130	140
60	64	79	C	95	D	140	150
70	74	89	C	95	E	150	160
80	84	99	D	120	F	160	170

\*\* with additional bar spacer only

**Type GC89SR...R: suggested insulator/bolt types**

Allowed clearance S			Insulator choice		Bolt choice		Max height
S' Min [mm]**	S Min [mm]	S Max [mm]	(3)	Ins. Length [mm]	(4)	Bolt Length [mm]	T [mm]
40	44	59	B	70	Z	100	129
50	54	69	B	70	A	110	139
60	64	79	B	70	B	120	149
70	74	89	C	95	C	130	159
80	84	99	C	95	D	140	169
90	94	109	D	120	E	150	179
100	104	119	D	120	F	160	189

\*\* with additional bar spacer only

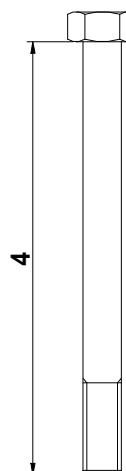
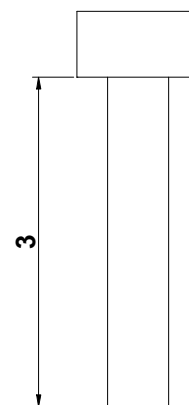

BAR CLAMP OUTLINES

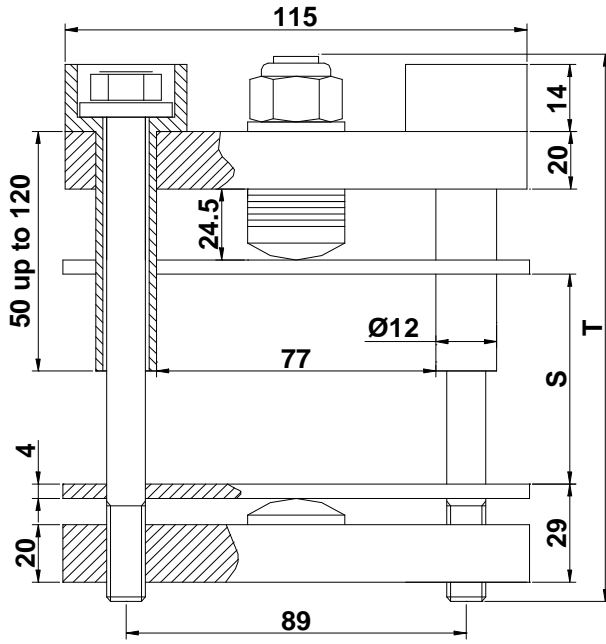

GC89BN...R

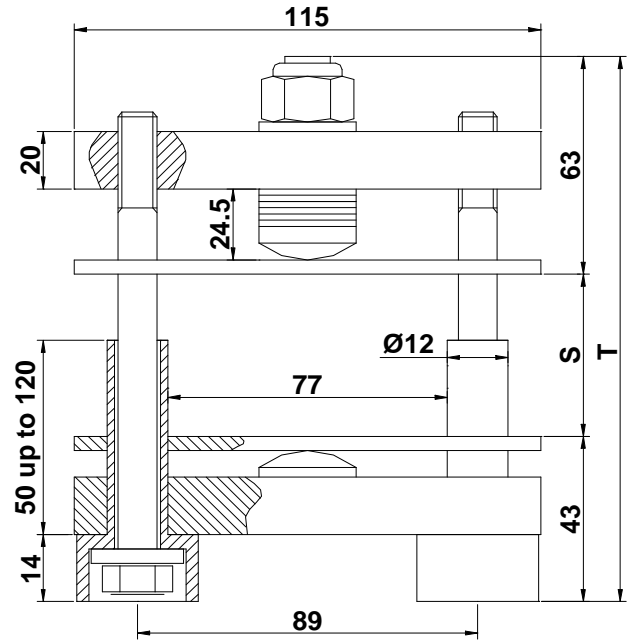

GC89BR...R

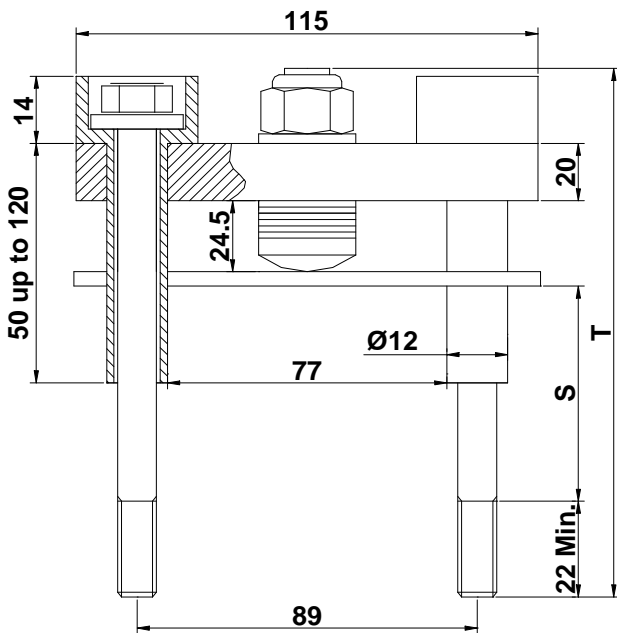

GC89SN...R

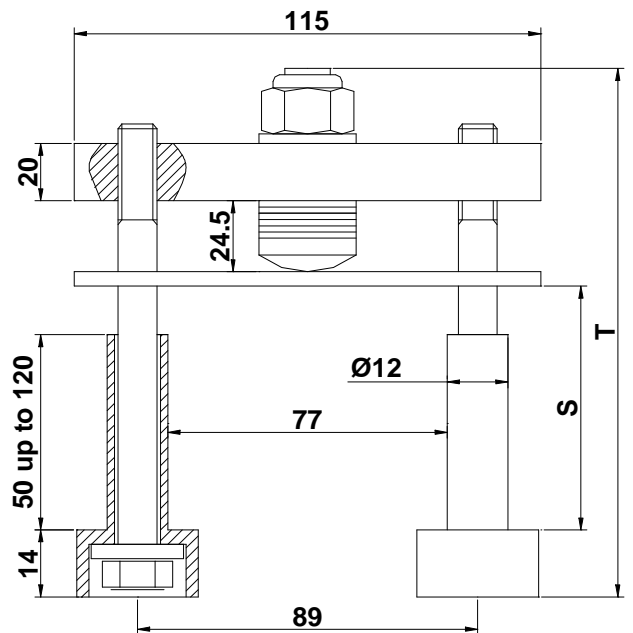

GC89SR...R

Dimensions in mm - Tolerances according to ISO 2768 MK

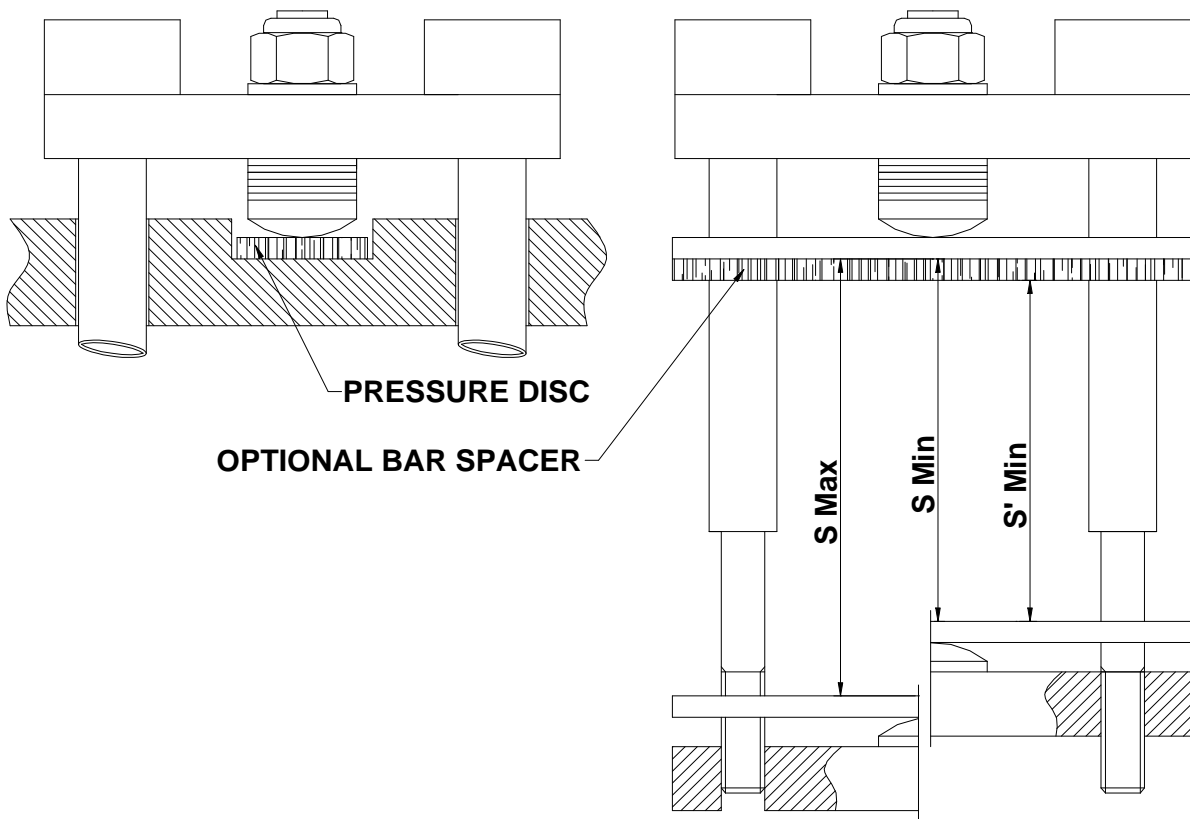

**SPECIAL ACCESSORIES**

The following special accessories are available on request (see ordering information table)

**Bar spacer**

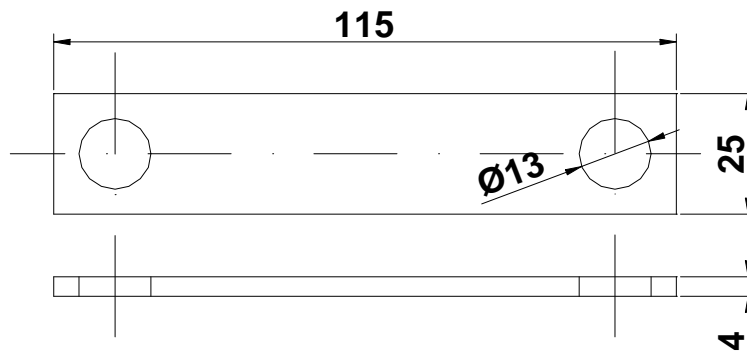

**Pressure disc**

Useful for grooved heatsink  
Suggested groove diameter 27mm +/- 0.5

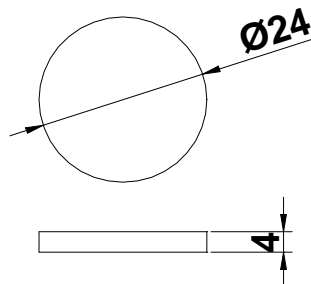

**Dimensions in mm - Tolerances according to ISO 2768 MK**

In the interest of product improvement Green Power Solutions reserves the right to change any specification given in this data sheet without notice.