

SOJ, TSOP
Commercial Temp
Industrial Temp

32K x 8

256Kb Asynchronous SRAM

7, 8, 10, 12, 15 ns
3.3 V V_{DD}
Corner V_{DD} and V_{SS}

Features

- Fast access time: 7, 8, 10, 12, 15 ns
- 75/65/50/50/50 mA at max cycle rate
- Single 3.3 V \pm 0.3 V power supply
- All inputs and outputs are TTL-compatible
- Fully static operation
- Industrial Temperature Option: -40° to 85° C
- Package line up
 - SJ: 300 mil, 28-pin SOJ package
 - TS: 8 mm x 13.4 mm, 28-pin TSOP Type I package

Description

The GS70328 is a high speed CMOS static RAM organized as 32,763 words by 8 bits. Static design eliminates the need for external clocks or timing strobes. The GS70328 operates on a single 3.3 V power supply, and all inputs and outputs are TTL-compatible. The GS70328 is available in 300 mil, 28-pin SOJ and 8 x 13.4 mm², 28-pin TSOP Type-I packages.

Pin Descriptions

Symbol	Description
A ₀ –A ₁₄	Address input
DQ ₁ –DQ ₈	Data input/output
CE	Chip enable input
WE	Write enable input
OE	Output enable input
V _{DD}	+3.3 V power supply
V _{SS}	Ground
NC	No connect

Pin Configuration

Top view

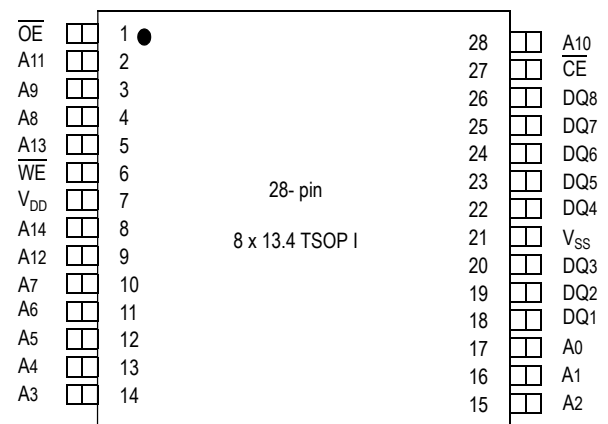
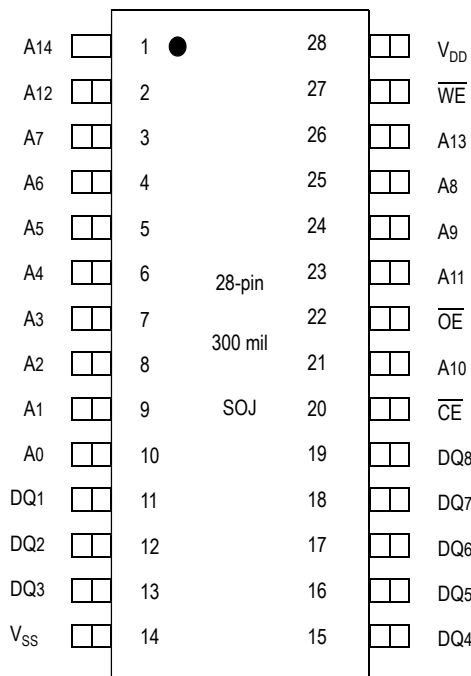

Block Diagram

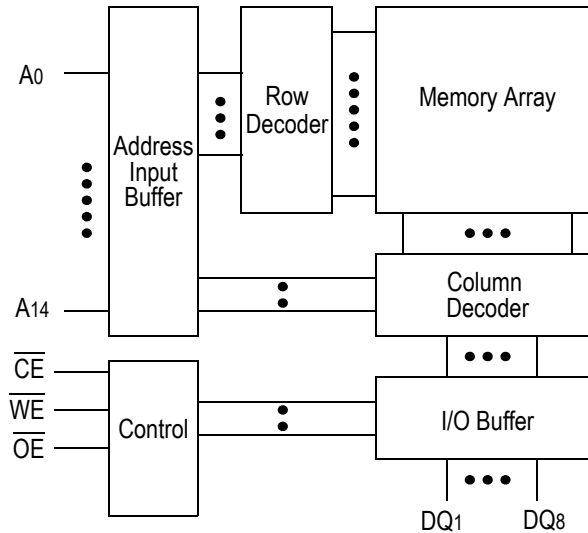

Truth Table

$\overline{\text{CE}}$	$\overline{\text{OE}}$	$\overline{\text{WE}}$	DQ1 to DQ8	V_{DD} Current
H	X	X	Not Selected	ISB1, ISB2
L	L	H	Read	IDD
L	X	L	Write	
L	H	H	High Z	

Note: X: "H" or "L"

Absolute Maximum Ratings

Parameter	Symbol	Rating	Unit
Supply Voltage	V_{DD}	-0.5 to +4.6	V
Input Voltage	V_{IN}	-0.5 to $V_{\text{DD}} + 0.5$ (≤ 4.6 V max.)	V
Output Voltage	V_{OUT}	-0.5 to $V_{\text{DD}} + 0.5$ (≤ 4.6 V max.)	V
Allowable power dissipation	PD	0.7	W
Storage temperature	T_{STG}	-55 to 150	$^{\circ}\text{C}$

Note:

Permanent device damage may occur if Absolute Maximum Ratings are exceeded. Functional operation shall be restricted to Recommended Operating Conditions. Exposure to higher than recommended voltages for extended periods of time could affect device reliability.

Recommended Operating Conditions

Parameter	Symbol	Minimum	Typical	Maximum	Unit
Supply Voltage for -7/8/10/12	V_{DD}	3.0	3.3	3.6	V
Input High Voltage	V_{IH}	2.0	—	$V_{DD} + 0.3$	V
Input Low Voltage	V_{IL}	-0.3	—	0.8	V
Ambient Temperature, Commercial Range	T_{Ac}	0	—	70	°C
Ambient Temperature, Industrial Range	T_{AI}	-40	—	85	°C

Notes:

1. Input overshoot voltage should be less than $V_{DD} + 2\text{ V}$ and not exceed 20 ns.
2. Input undershoot voltage should be greater than -2 V and not exceed 20 ns.

Capacitance

Parameter	Symbol	Test Condition	Maximum	Unit
Input Capacitance	C_{IN}	$V_{IN} = 0\text{ V}$	5	pF
Output Capacitance	C_{OUT}	$V_{OUT} = 0\text{ V}$	7	pF

Notes:

1. Tested at $T_A = 25^\circ\text{C}$, $f = 1\text{ MHz}$
2. These parameters are sampled and are not 100% tested.

DC I/O Pin Characteristics

Parameter	Symbol	Test Conditions	Min	Max
Input Leakage Current	I_{IL}	$V_{IN} = 0\text{ to }V_{DD}$	-1 μA	1 μA
Output Leakage Current	I_{LO}	Output High Z $V_{OUT} = 0\text{ to }V_{DD}$	-1 μA	1 μA
Output High Voltage	V_{OH}	$I_{OH} = -4\text{ mA}$	2.4 V	—
Output Low Voltage	V_{OL}	$I_{LO} = +4\text{ mA}$	—	0.4 V

Power Supply Currents

Parameter	Symbol	Test Conditions	0 to 70°C					-40 to 85°C				
			7 ns	8 ns	10 ns	12 ns	15 ns	7 ns	8 ns	10 ns	12 ns	15 ns
Operating Supply Current	IDD	$\overline{CE} \leq V_{IL}$ All other inputs $\geq V_{IH}$ or $\leq V_{IL}$ Min. cycle time IOUT = 0 mA	75 mA	65 mA	50 mA	50 mA	50 mA	80 mA	70 mA	55 mA	55 mA	55 mA
Standby Current	ISB1	$\overline{CE} \geq V_{IH}$ All other inputs $\geq V_{IH}$ or $\leq V_{IL}$ Min. cycle time	35 mA	30 mA	25 mA	25 mA	25 mA	40 mA	35 mA	30 mA	30 mA	30 mA
Standby Current	ISB2	$\overline{CE} \geq V_{DD} - 0.2 V$ All other inputs $\geq V_{DD} - 0.2 V$ or $\leq 0.2 V$	1 mA					2 mA				

AC Test Conditions

Parameter	Conditions
Input high level	$V_{IH} = 2.4 V$
Input low level	$V_{IL} = 0.4 V$
Input rise time	$t_r = 1 V/ns$
Input fall time	$t_f = 1 V/ns$
Input reference level	1.4 V
Output reference level	1.4 V
Output load	Fig. 1 & 2

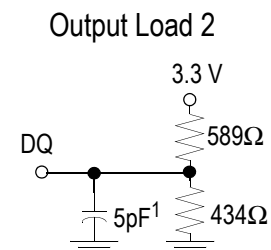
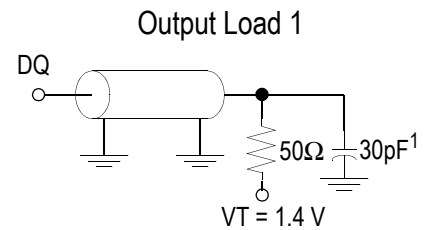

Notes:

1. Include scope and jig capacitance
2. Test conditions as specified with output loading as shown in Fig. 1 unless otherwise noted
3. Output load 2 for tLZ, tHZ, toLZ and toHZ

AC Characteristics
Read Cycle

Parameter	Symbol	-7		-8		-10		-12		-15		Unit
		Min	Max	Min	Max	Min	Max	Min	Max	Min	Max	
Read cycle time	t _{RC}	7	—	8	—	10	—	12	—	15	—	ns
Address access time	t _{AA}	—	7	—	8	—	10	—	12	—	15	ns
Chip enable access time (\overline{CE})	t _{AC}	—	7	—	8	—	10	—	12	—	15	ns
Output enable to output valid (\overline{OE})	t _{OE}	—	3.5	—	4	—	5	—	6	—	7	ns
Output hold from address change	t _{OH}	2	—	2	—	2	—	3	—	3	—	ns
Chip enable to output in low Z (\overline{CE})	t _{LZ} *	2	—	2	—	2	—	3	—	3	—	ns
Output enable to output in low Z (\overline{OE})	t _{OLZ} *	0	—	0	—	0	—	0	—	0	—	ns
Chip disable to output in High Z (\overline{CE})	t _{HZ} *	—	3.5	—	4	—	5	—	6	—	7	ns
Output disable to output in High Z (\overline{OE})	t _{OHZ} *	—	3	—	3.5	—	4	—	5	—	6	ns

* These parameters are sampled and are not 100% tested

Read Cycle 1: $\overline{CE} = \overline{OE} = V_{IL}$, $\overline{WE} = V_{IH}$

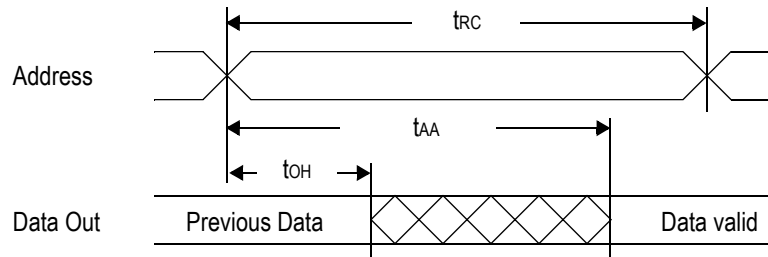

Read Cycle 2: $\overline{WE} = V_{IH}$

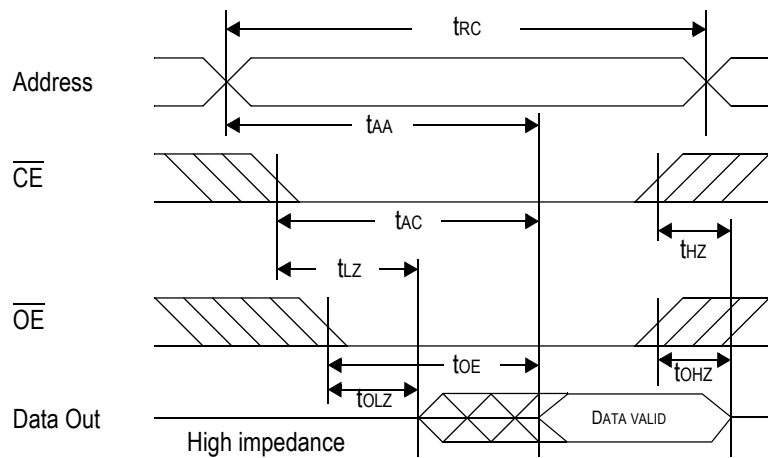

Write Cycle

Parameter	Symbol	-7		-8		-10		-12		-15		Unit
		Min	Max	Min	Max	Min	Max	Min	Max	Min	Max	
Write cycle time	tWC	7	—	8	—	10	—	12	—	15	—	ns
Address valid to end of write	tAW	5	—	5.5	—	7	—	10	—	13	—	ns
Chip enable to end of write	tCW	5	—	5.5	—	7	—	10	—	13	—	ns
Data set up time	tDW	3.5	—	4	—	5	—	7	—	10	—	ns
Data hold time	tDH	0	—	0	—	0	—	0	—	0	—	ns
Write pulse width	tWP	5	—	5.5	—	7	—	10	—	13	—	ns
Address set up time	tAS	0	—	0	—	0	—	0	—	0	—	ns
Write recovery time (\overline{WE})	tWR	0	—	0	—	0	—	0	—	0	—	ns
Write recovery time (\overline{CE})	tWR1	0	—	0	—	0	—	0	—	0	—	ns
Output Low Z from end of write	tWLZ*	2	—	2	—	2	—	3	—	3	—	ns
Write to output in High Z	tWHZ*	—	3	—	3.5	—	4	—	5	—	5	ns

* These parameters are sampled and are not 100% tested

Write Cycle 1: $\overline{\text{WE}}$ control

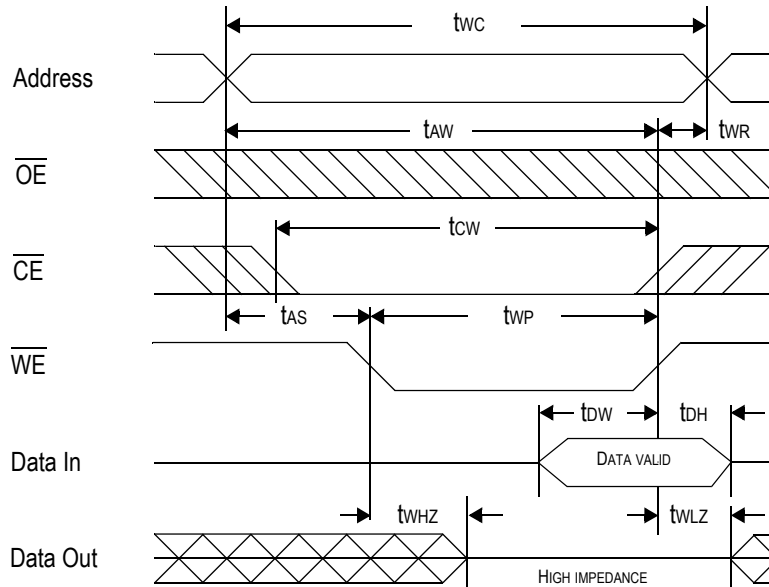

Write Cycle 2: $\overline{\text{CE}}$ control

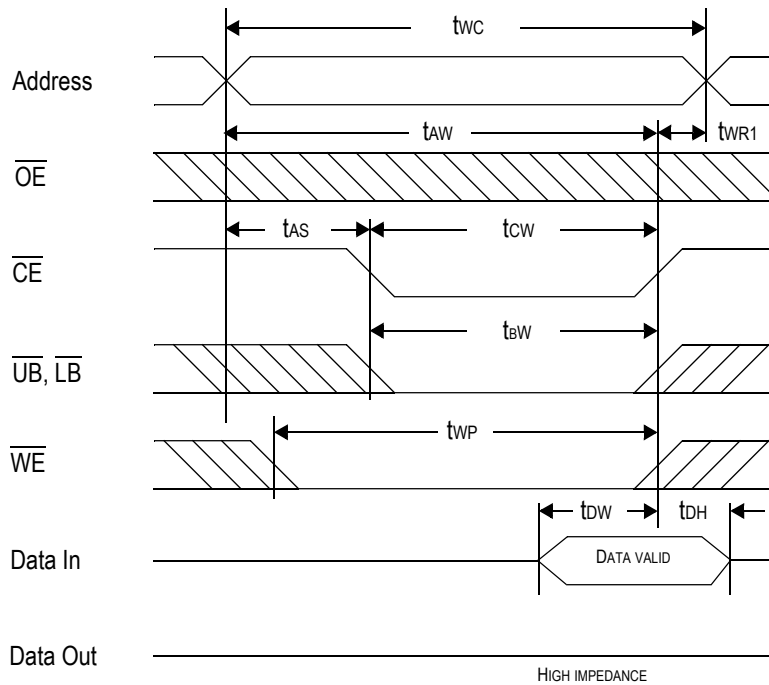

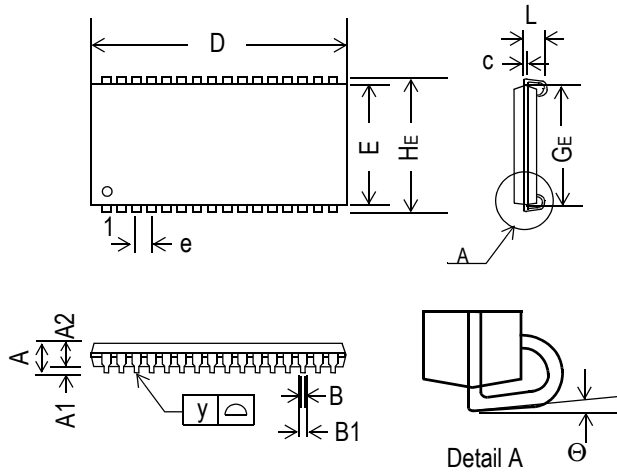
28-Pin SOJ, 300 mil

Symbol	Dimension in inch			Dimension in mm		
	min	nom	max	min	nom	max
A	—	—	0.148	—	—	3.76
A1	0.025	—	—	0.64	—	—
A2	0.095	0.100	0.105	2.41	2.54	2.67
B	0.015	—	0.020	0.38	—	0.51
B1	0.026	0.028	0.032	0.66	0.71	0.81
c	0.008	0.010	0.012	0.20	0.25	0.30
D	0.705	0.71	0.715	17.91	18.03	18.16
E	0.295	0.300	0.305	7.49	7.62	7.75
e	—	0.05	—	—	1.27	—
HE	0.330	0.335	0.340	8.38	8.51	8.64
GE	0.255	0.265	0.275	6.48	6.73	6.985
L	0.082	—	—	2.08	—	—
y	—	—	0.004	—	—	0.10
Θ	0°	—	10°	0°	—	10°

Notes:

1. Dimension D & E do not include interlead flash
2. Dimension B1 does not include dambar protrusion/intrusion
3. Controlling dimension: inches

28-Pin TSOP-I, 8 mm x 13.4 mm

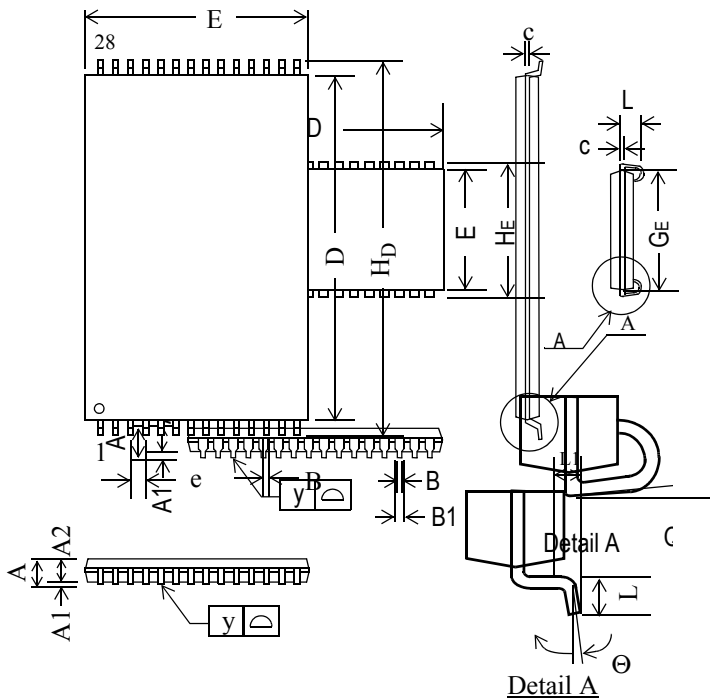

Symbol	Dimension in inch			Dimension in mm		
	min	nom	max	min	nom	max
A	—	—	0.047	—	—	1.20
A1	0.002	—	0.006	0.05	—	0.15
A2	0.035	0.040	0.041	0.90	1.00	1.05
B	0.007	0.008	0.011	0.17	0.20	0.27
D	—	0.465	—	—	11.8	—
H _D	—	.528	—	—	13.4	—
c	0.004	0.006	0.008	0.10	0.15	0.21
E	—	0.315	—	—	8.00	—
e	—	0.022	—	—	0.55	—
L	0.020	0.024	0.028	0.50	0.60	0.70
L1	0.024	0.032	0.040	0.60	0.80	1.00
y	—	—	0.003	—	—	0.08
Θ	0°	—	5°	0°	—	5°

- Notes:
1. Dimension D & E do not include interlead flash
 2. Dimension B1 does not include dambar protrusion/intrusion
 3. Controlling dimension: inches
 4. Profile tolerance zones for D and E do not include mold protrusion. Allowable mold protrusion on E is 0.15 mm per side and on D is 0.25 mm per side.

Ordering Information

Part Number *	Package	Access Time	Temp. Range	Status
GS70328SJ-7	300-mil SOJ	7 ns	Commercial	
GS70328SJ-8	300-mil SOJ	8 ns	Commercial	
GS70328SJ-10	300-mil SOJ	10 ns	Commercial	
GS70328SJ-12	300-mil SOJ	12 ns	Commercial	
GS70328SJ-15	300-mil SOJ	15 ns	Commercial	
GS70328SJ-7I	300-mil SOJ	7 ns	Industrial	
GS70328SJ-8I	300-mil SOJ	8 ns	Industrial	
GS70328SJ-10I	300-mil SOJ	10 ns	Industrial	
GS70328SJ-12I	300-mil SOJ	12 ns	Industrial	
GS70328SJ-15I	300-mil SOJ	15 ns	Industrial	
GS70328TS-7	TSOP-I 8 x 13.4 mm ²	7 ns	Commercial	
GS70328TS-8	TSOP-I 8 x 13.4 mm ²	8 ns	Commercial	
GS70328TS-10	TSOP-I 8 x 13.4 mm ²	10 ns	Commercial	
GS70328TS-12	TSOP-I 8 x 13.4 mm ²	12 ns	Commercial	
GS70328TS-15	TSOP-I 8 x 13.4 mm ²	15 ns	Commercial	
GS70328TS-7I	TSOP-I 8 x 13.4 mm ²	7 ns	Industrial	
GS70328TS-8I	TSOP-I 8 x 13.4 mm ²	8 ns	Industrial	
GS70328TS-10I	TSOP-I 8 x 13.4 mm ²	10 ns	Industrial	
GS70328TS-12I	TSOP-I 8 x 13.4 mm ²	12 ns	Industrial	
GS70328TS-15I	TSOP-I 8 x 13.4 mm ²	15 ns	Industrial	

* Customers requiring delivery in Tape and Reel should add the character "T" to the end of the part number. For example: GS70328TP-8T

Revision History

Rev. Code: Old; New	Types of Changes Format or Content	Page #/Revisions/Reason
1.03 8/1999; 1.04 11/1999	Content	• Added 12ns speed bin information to 70328 datasheet.
GS70328Rev1.04 12/1999KRev 1.05 2/2000L	Format/Content	• GSI Logo
Rev 1.05 2/2000L; Rev1.06 6/2000	Content	• Nominal value for H _D on the TSOP-I 28-pin package changed to 13.4
Rev1.06; Rev1.07	Format/Content	• Updated format to conform to Tech Pubs standards • Corrected errors in both case diagrams
70328_r1_07; 70328_r1_08	Content	• Added 12 ns reference to Parameter column in Recommended Operating Conditions table on page 3
70328_r1_08; 70328_r1_09	Content	• Added 15 ns references to entire document
70328_r1_09; 70328_r1_10	Content	• Removed 6 ns speed bin from entire document