

209-Bump BGA
 Commercial Temp
 Industrial Temp



18Mb Σ 1x2Lp Double Data Rate SigmaRAM™ SRAM

250 MHz–333 MHz
 1.8 V V_{DD}
 1.8 V and 1.5 V I/O

Features

- Double Data Rate Read and Write mode
- JEDEC-standard SigmaRAM™ pinout and package
- 1.8 V +150/–100 mV core power supply
- 1.5 V or 1.8 V I/O supply
- Pipelined read operation
- Fully coherent read and write pipelines
- Echo Clock outputs track data output drivers
- ZQ mode pin for user-selectable output drive strength
- 2 user-programmable chip enable inputs for easy depth expansion
- IEEE 1149.1 JTAG-compatible Boundary Scan
- 209-bump, 14 mm x 22 mm, 1 mm bump pitch BGA package
- Pin-compatible with future 36Mb, 72Mb, and 144Mb devices

		- 333
Pipeline mode	tKHKH	3.0 ns
	tKHQV	1.6 ns

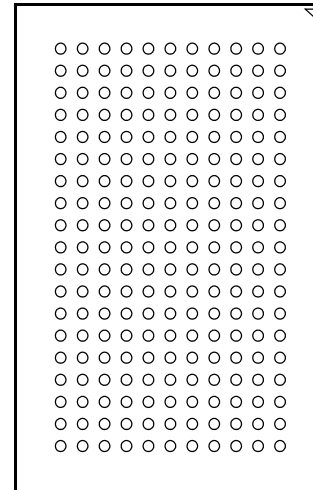

Bottom View

**209-Bump, 14 mm x 22 mm BGA
 1 mm Bump Pitch, 11 x 19 Bump Array**

SigmaRAM Family Overview

GS8170DD18/36 SigmaRAMs are built in compliance with the SigmaRAM pinout standard for synchronous SRAMs. They are 18,874,368-bit (18Mb) SRAMs. These are the first in a family of wide, very low voltage CMOS I/O SRAMs designed to operate at the speeds needed to implement economical high performance networking systems.

GSI's SRAMs are offered in a number of configurations that emulate other synchronous SRAMs, such as Burst RAMs, NBT, Late Write, or Double Data Rate (DDR) SRAMs. The logical differences between the protocols employed by these RAMs hinge mainly on various combinations of address bursting, output data registering and write cueing. The SRAM™ family standard allows a user to implement the interface protocol best suited to the task at hand.

Functional Description

Because SigmaRAMs are synchronous devices, address and read/write control inputs are captured on the rising edge of the input clock. Write cycles are internally self-timed and initiated by the rising edge of the clock input. This feature eliminates complex off-chip write pulse generation required by asynchronous SRAMs and simplifies input signal timing. In

DDR mode the device captures Data In on both rising and falling edges of clock and drives data on both clock edges as well.

Because the DDR SRAM always transfers data in two halves, A0 is internally set to 0 for the first half of each read or write transfer, and automatically incremented to 1 for the falling edge transfer. The address field of a DDR SRAM is always one address pin less than the advertised index depth (e.g., the 1M x 18 has a 512k addressable index).

In Pipeline mode, Single Data Rate (SDR) SRAMs incorporate a rising-edge-triggered output register. In DDR mode, rising- and falling-edge-triggered output registers are employed. For read cycles, a DDR SRAM's output data is staged at the input of an edge-triggered output register during the access cycle and then released to the output drivers at the next rising and subsequent falling edge of clock.

GS817x18/36/72B SRAMs are implemented with GSI's high performance CMOS technology and are packaged in a 209-bump BGA.

8170DD36 512K x 36 Pinout

512K x 36 Common I/O—Top View

	1	2	3	4	5	6	7	8	9	10	11
A	NC	NC	A	E2	A	ADV	A	E3	A	DQb	DQb
B	NC	NC	MCL	NC	A	\overline{W}	A	MCL	NC	DQb	DQb
C	NC	NC	NC	MCL	NC (144M)	$\overline{E1}$	NC	NC	MCL	DQb	DQb
D	NC	NC	V _{SS}	NC	NC	MCL	NC	NC	V _{SS}	DQb	DQb
E	NC	DQc	V _{DDQ}	V _{DDI}	V _{DD}	V _{DD}	V _{DD}	V _{DDI}	V _{DDQ}	NC	DQb
F	DQc	DQc	V _{SS}	V _{SS}	V _{SS}	ZQ	V _{SS}	V _{SS}	V _{SS}	NC	NC
G	DQc	DQc	V _{DDQ}	V _{DDQ}	V _{DD}	EP2	V _{DD}	V _{DDQ}	V _{DDQ}	NC	NC
H	DQc	DQc	V _{SS}	V _{SS}	V _{SS}	EP3	V _{SS}	V _{SS}	V _{SS}	NC	NC
J	DQc	DQc	V _{DDQ}	V _{DDQ}	V _{DD}	MCH	V _{DD}	V _{DDQ}	V _{DDQ}	NC	NC
K	CQ2	$\overline{CQ2}$	CK	NC	V _{SS}	MCL	V _{SS}	NC	NC	$\overline{CQ1}$	CQ1
L	NC	NC	V _{DDQ}	V _{DDQ}	V _{DD}	MCL	V _{DD}	V _{DDQ}	V _{DDQ}	DQa	DQa
M	NC	NC	V _{SS}	V _{SS}	V _{SS}	MCH	V _{SS}	V _{SS}	V _{SS}	DQa	DQa
N	NC	NC	V _{DDQ}	V _{DDQ}	V _{DD}	MCH	V _{DD}	V _{DDQ}	V _{DDQ}	DQa	DQa
P	NC	NC	V _{SS}	V _{SS}	V _{SS}	MCL	V _{SS}	V _{SS}	V _{SS}	DQa	DQa
R	DQd	NC	V _{DDQ}	V _{DDI}	V _{DD}	V _{DD}	V _{DD}	V _{DDI}	V _{DDQ}	DQa	NC
T	DQd	DQd	V _{SS}	NC	NC	MCL	NC	NC	V _{SS}	NC	NC
U	DQd	DQd	NC	A	NC (72M)	A	NC (36M)	A	NC	NC	NC
V	DQd	DQd	A	A	A	A1	A	A	A	NC	NC
W	DQd	DQd	TMS	TDI	A	MCL	A	TDO	TCK	NC	NC

• 2001.03

11 x 19 Bump BGA—14 x 22 mm² Body—1 mm Bump Pitch

8170DD18 1M x 18 Pinout

1M x 18 Common I/O—Top View

	1	2	3	4	5	6	7	8	9	10	11
A	NC	NC	A	E2	A	ADV	A	E3	A	NC	NC
B	NC	NC	MCL	NC	A	\overline{W}	A	NC	NC	NC	NC
C	NC	NC	NC	NC	NC (144M)	$\overline{E1}$	A	NC	MCL	NC	NC
D	NC	NC	V _{SS}	NC	NC	MCL	NC	NC	V _{SS}	NC	NC
E	NC	DQb	V _{DDQ}	V _{DDI}	V _{DD}	V _{DD}	V _{DD}	V _{DDI}	V _{DDQ}	NC	NC
F	DQb	DQb	V _{SS}	V _{SS}	V _{SS}	ZQ	V _{SS}	V _{SS}	V _{SS}	NC	NC
G	DQb	DQb	V _{DDQ}	V _{DDQ}	V _{DD}	EP2	V _{DD}	V _{DDQ}	V _{DDQ}	NC	NC
H	DQb	DQb	V _{SS}	V _{SS}	V _{SS}	EP3	V _{SS}	V _{SS}	V _{SS}	NC	NC
J	DQb	DQb	V _{DDQ}	V _{DDQ}	V _{DD}	MCH	V _{DD}	V _{DDQ}	V _{DDQ}	NC	NC
K	CQ2	$\overline{CQ2}$	CK	NC	V _{SS}	MCL	V _{SS}	NC	NC	$\overline{CQ1}$	CQ1
L	NC	NC	V _{DDQ}	V _{DDQ}	V _{DD}	MCL	V _{DD}	V _{DDQ}	V _{DDQ}	DQa	DQa
M	NC	NC	V _{SS}	V _{SS}	V _{SS}	MCH	V _{SS}	V _{SS}	V _{SS}	DQa	DQa
N	NC	NC	V _{DDQ}	V _{DDQ}	V _{DD}	MCH	V _{DD}	V _{DDQ}	V _{DDQ}	DQa	DQa
P	NC	NC	V _{SS}	V _{SS}	V _{SS}	MCL	V _{SS}	V _{SS}	V _{SS}	DQa	DQa
R	NC	NC	V _{DDQ}	V _{DDI}	V _{DD}	V _{DD}	V _{DD}	V _{DDI}	V _{DDQ}	DQa	NC
T	NC	NC	V _{SS}	NC	NC	MCL	NC	NC	V _{SS}	NC	NC
U	NC	NC	NC	A	NC (72M)	A	NC (36M)	A	NC	NC	NC
V	NC	NC	A	A	A	A1	A	A	A	NC	NC
W	NC	NC	TMS	TDI	A	MCL	A	TDO	TCK	NC	NC

• 2001.03

11 x 19 Bump BGA—14 x 22 mm² Body—1 mm Bump Pitch

Pin Description Table

Pin Location	Symbol	Description	Type	Comments
A3, A5, A7, A9, B7, U4, U6, U8, V3, V4, V5, V6, V7, V8, V9, W5, W7	A	Address	Input	—
C7	A	Address	Input	x18 version only
B5	A	Address	Input	x18 and x36 versions
A6	ADV	Advance	Input	Active High
K3	CK	Clock	Input	Active High
K1, K11	CQ	Echo Clock	Output	Active High
K2, K10	\overline{CQ}	Echo Clock	Output	Active Low
E2, F1, F2, G1, G2, H1, H2, J1, J2, L10, L11, M10, M11, N10, N11, P10, P11, R10	DQ	Data I/O	Input/Output	x18 and x36 versions
A10, A11, B10, B11, C10, C11, D10, D11, E11, R1, T1, T2, U1, U2, V1, V2, W1, W2	DQ	Data I/O	Input/Output	x36 version
C6	$\overline{E1}$	Chip Enable	Input	Active Low
A4, A8	E2 & E3	Chip Enable	Input	Programmable Active High or Low
G6, H6	EP2 & EP3	Chip Enable Program Pin	Input	—
W9	TCK	Test Clock	Input	Active High
W4	TDI	Test Data In	Input	—
W8	TDO	Test Data Out	Output	—
W3	TMS	Test Mode Select	Input	—
J6, M6, N6	MCH	Must Connect High	Input	Active High (all versions)
B3, C9, D6, K6, L6, P6, T6, W6	MCL	Must Connect Low	Input	Active Low (all versions)
B8, C4	MCL	Must Connect Low	Input	Active Low (x36 version)

Pin Description Table

Pin Location	Symbol	Description	Type	Comments
A1, A2, B1, B2, B4, B9, C1, C2, C3, C5, C8, D1, D2, D4, D5, D7, D8, E1, E10, F10, F11, G10, G11, H10, H11, J10, J11, K4, K8, K9, L1, L2, M1, M2, N1, N2, P1, P2, R2, R11, T4, T5, T7, T8, T10, T11, U3, U5, U7, U9, U10, U11, V10, V11, W10, W11	NC	No Connect	—	Not connected to die (all versions)
C7	NC	No Connect	—	Not connected to die (x36 version)
A1, A2, B1, B2, B4, B9, C1, C2, C3, C8, D1, D2, E1, E10, F10, F11, G10, G11, H10, H11, J10, J11, L1, L2, M1, M2, N1, N2, P1, P2, R2, R11, T10, T11, U10, U11, V10, V11, W10, W11	NC	No Connect	—	Not connected to die (x36/x18 versions)
A10, A11, B8, B10, B11, C4, C10, C11, D10, D11, E11, R1, T1, T2, U1, U2, V1, V2, W1, W2	NC	No Connect	—	Not connected to die (x18 version)
B6	\overline{W}	Write	Input	Active Low
E5, E6, E7, G5, G7, J5, J7, L5, L7, N5, N7, R5, R6, R7	V _{DD}	Core Power Supply	Input	1.8 V Nominal
E3, E4, E8, E9, J3, J4, J8, J9, L3, L4, L8, L9, N3, N4, N8, N9, R3, R4, R8, R9	V _{DDQ}	Output Driver Power Supply	Input	1.8 V or 1.5 V Nominal
E4, E8, R4, R8	V _{DDI}	Input Buffer Power Supply	Input	1.8 V or 1.5 V Nominal
D3, D9, F3, F4, F5, F7, F8, F9, H3, H4, H5, H7, H8, H9, K5, K7, M3, M4, M5, M7, M8, M9, P3, P4, P5, P7, P8, P9, T3, T9	V _{SS}	Ground	Input	—
F6	ZQ	Output Impedance Control	Input	Low = Low Impedance [High Drive] High = High Impedance [Low Drive]

Background

The central characteristics of Σ RAMs are that they are extremely fast and consume very little power. Because both operating and interface power is low, Σ RAMs can be implemented in a wide (x36) configuration, providing very high single package bandwidth (in excess of 20 Gb/s in ordinary pipelined configuration) and very low random access latency (5 ns). The use of very low voltage circuits in the core and 1.8 V or 1.5 V interface voltages allow the speed, power and density performance of Σ RAMs.

The Σ RAM family of pinouts has been designed to support a number of different common read and write protocols. The following timing diagrams provide a quick comparison between the late write read and write protocol and the DDR protocol options available in the context of the Σ RAM standard. This particular datasheet covers the Double Data Rate (DDR) Σ RAM.

The character of the applications for fast synchronous SRAMs in networking systems are extremely diverse. Σ RAMs have been developed to address the broad variety of applications in the networking market in a manner that can be supported with a unified development and manufacturing infrastructure. Σ RAMs address each of the bus protocol options commonly found in networking systems. This allows the Σ RAM to find application in radical shrinks and speed-ups of existing networking chip sets that were designed for use with older SRAMs, like the NBT, Late Write, or Double Data Rate SRAMs, as well as with new chip sets and ASIC's that employ the Echo Clocks and realize the full potential of the Σ RAMs.

Mode Selection Truth Table Standard

L6	M6	J6	Name	Function	Analogous to...	In This Data Sheet?
0	0	0	$\Sigma 1 \times 1 \text{E} \text{f}$	Early Write, Flow through Read	Flow through Burst RAM	No
0	0	1	$\Sigma 1 \times 1 \text{L} \text{f}$	Late Write, Flow through Read	Flow through NBT SRAM	No
0	1	0		RFU		n/a
0	1	1	$\Sigma 1 \times 2 \text{L} \text{p}$	DDR	Double Data Rate SRAM	Yes
1	0	0	$\Sigma 1 \times 1 \text{E} \text{p}$	Early Write, Pipelined Read	Pipelined Burst RAM	No
1	0	1	$\Sigma 1 \times 1 \text{D} \text{p}$	Double Late Write, Pipelined Read	Pipelined NBT SRAM	No
1	1	0	$\Sigma 1 \times 1 \text{L} \text{p}$	Late Write, Pipelined Read	Pipelined Late Write SRAM	No

All address and control inputs (with the exception of PE2, PE3, ZQ, and the mode pins, L6, M6, and J6) are synchronized to rising clock edges. Data in is captured on both rising and falling edges of CK. Read and write operations must be initiated with the Advance/Load pin ($\overline{\text{ADV}}$) held low, in order to load the new address. Device activation is accomplished by asserting all three of the Chip Enable inputs ($\overline{\text{E1}}$, E2, and E3). Deassertion of any one of the Enable inputs will deactivate the device. **It should be noted that ONLY deactivation of the RAM via E2 and/or E3 deactivates the Echo Clocks, CQ1–CQ2.**

Read Operations

Double Data Rate Read

In applications where a data rate markedly faster than the RAM's latency is desired, Double Data Rate reads double the data transfer rate (read or write bandwidth) achieved in Pipeline mode while keeping the RAM's clock frequency constant. In Double Data Rate mode, the RAM multiplexes the results of a read out of the RAM on half the usual number of data pins. The output register/mux behaves just as if it were in Pipeline mode for the first transfer, but then makes a second transfer in response to the next falling edge of clock as well. SigmaRAM DDR RAMs burst in linear order only.

Double Data Rate Pipelined Read

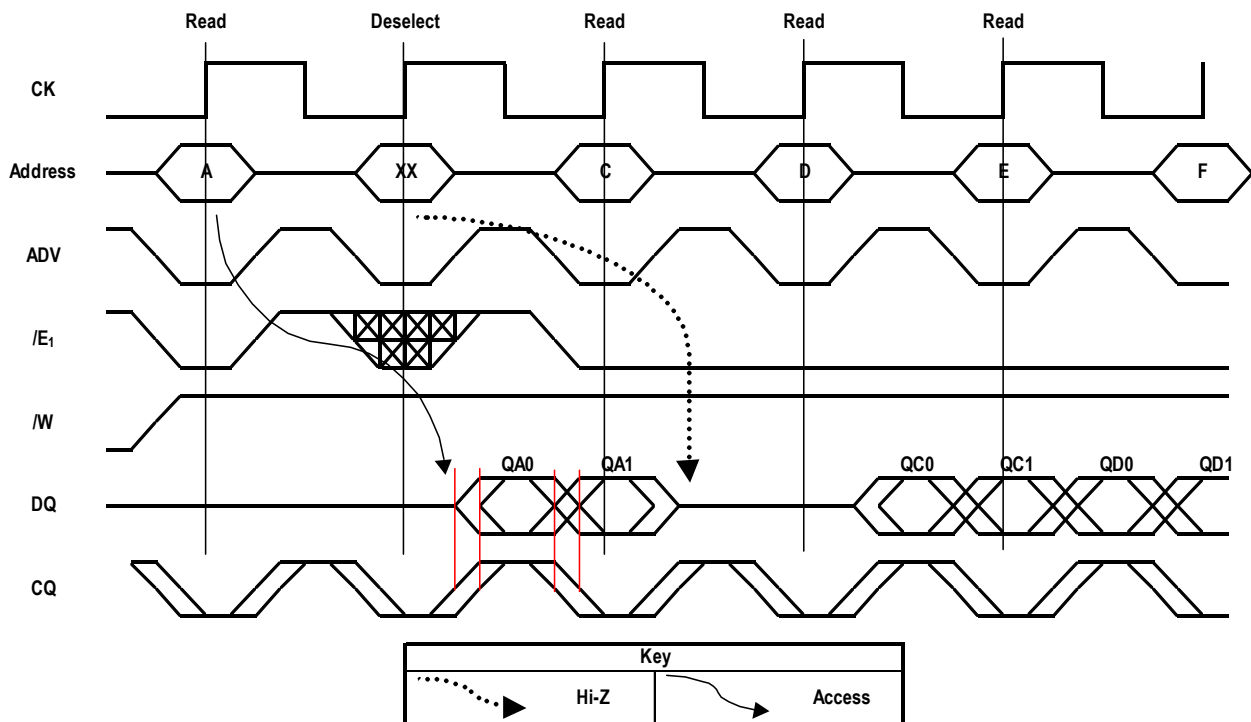

Write Operations

Write operation occurs when the following conditions are satisfied at the rising edge of clock: All three chip enables ($\overline{E1}$, E2, and E3) are active, the write enable input signal (\overline{W}) is asserted low, and ADV is asserted low.

Double Data Rate Write

A Double Data Rate Write is a specialized form of Late Write. In Double Data Rate mode, the RAM will capture Data In on both rising and falling edges of the RAM clock, CK, beginning with the rising edge of clock that follows the capture of the write address and command.

SigmaRAM Double Data Rate Read and Write

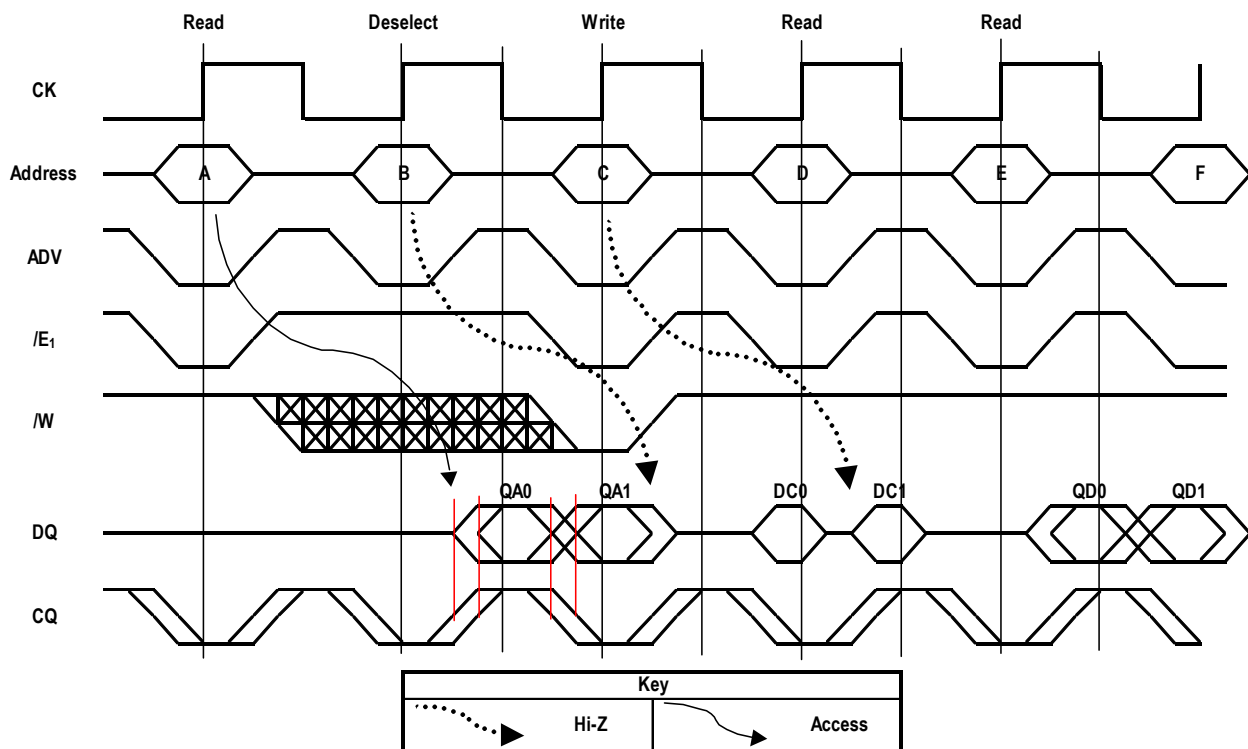

Special Functions

Burst Cycles

SRAMs provide an on-chip burst address generator that can be utilized, if desired, to further simplify burst read or write implementations. The ADV control pin, when driven high, commands the SRAM to advance the internal address counter and use the counter generated address to read or write the SRAM. The starting address for the first cycle in a burst cycle series is loaded into the SRAM by driving the ADV pin low, into Load mode.

SigmaRAM DDR Burst Read with Counter Wrap-around

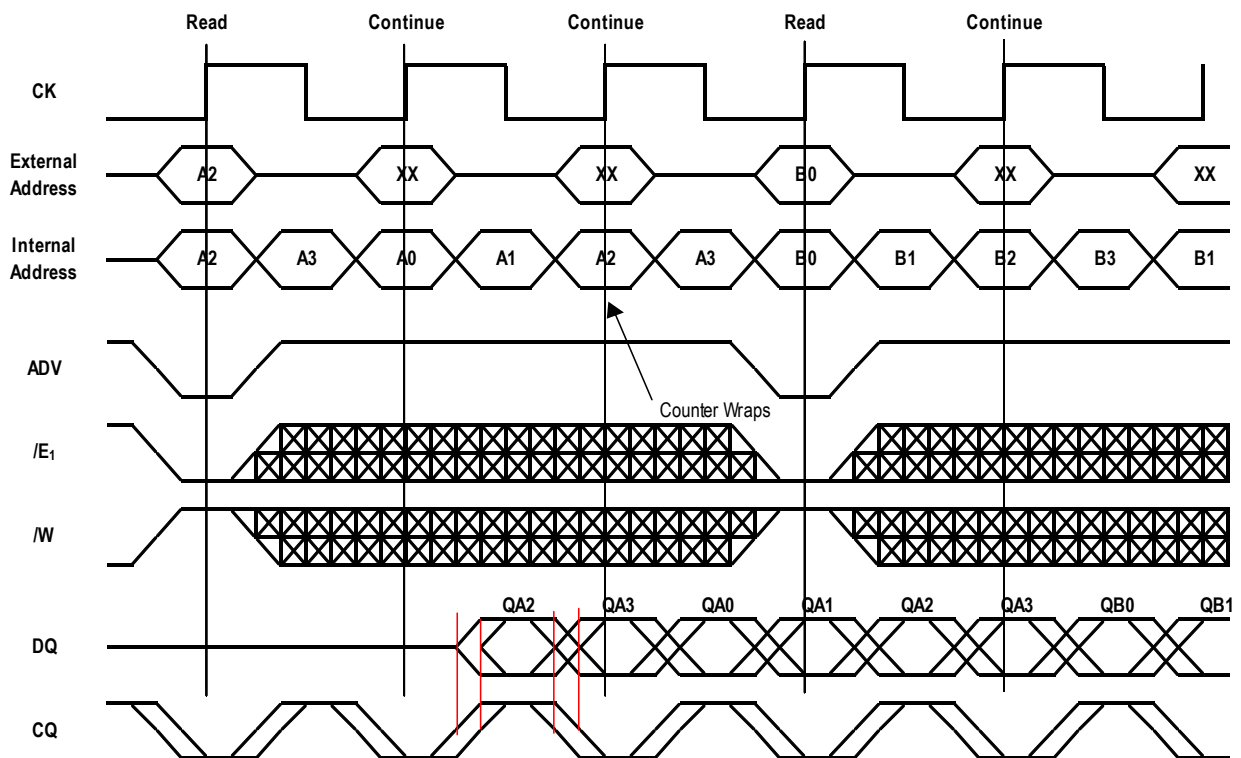

SigmaRAM DDR Burst Write with Counter Wrap-around

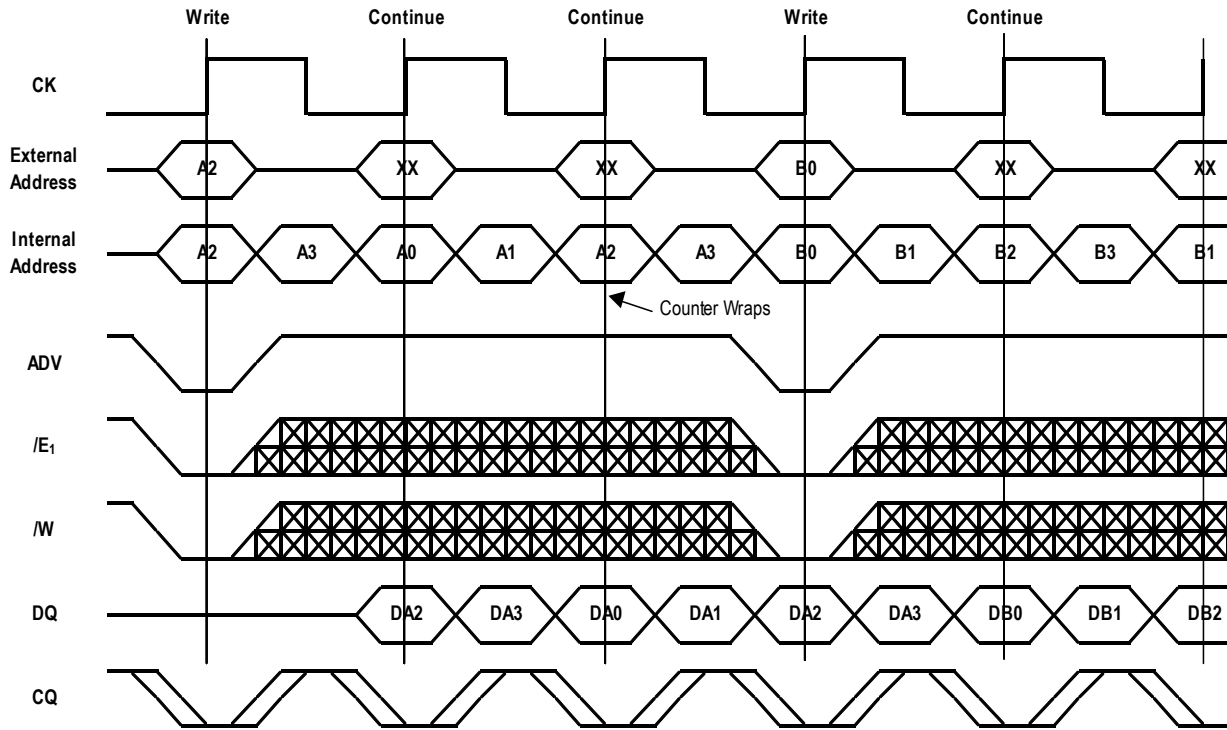

Burst Order

The burst address counter wraps around to its initial state after four internal addresses (the loaded address and three more) have been accessed. SigmaRAMs always count in linear burst order.

Linear Burst Order

	A[1:0]	A[1:0]
1st address (Rising Edge CK)	00	10
2nd address (Falling Edge CK)	01	11
3rd address (Rising Edge CK)	10	00
4th address (Falling Edge CK)	11	01

Notes:

1. The burst counter wraps to initial state on the 3rd rising edge of clock.
2. The DDR SigmaRAM always begins an read or write at A0 = 0. A0 is internally set to 0 at the rising edge of clock and is not available to the user.

Echo Clock

ΣRAMs feature Echo Clocks, CQ1, CQ2, $\overline{CQ1}$, and $\overline{CQ2}$ that track the performance of the output drivers. The Echo Clocks are delayed copies of the main RAM clock, CK. Echo Clocks are designed to track changes in output driver delays due to variance in die temperature and supply voltage. The Echo Clocks are designed to fire with the rest of the data output drivers. SigmaRAMs provide both in-phase, or true, Echo Clock outputs (CQ1 and CQ2) and inverted Echo Clock outputs ($\overline{CQ1}$ and $\overline{CQ2}$).

It should be noted that deselection of the RAM via E2 and E3 also deselection of the Echo Clock output drivers. The deselection of Echo Clock drivers is always pipelined to the same degree as output data. **Deselection of the RAM via E1 does not deactivate the Echo Clocks.**

Programmable Enables

ΣRAMs feature two user-programmable chip enable inputs, E2 and E3. The sense of the inputs, whether they function as active low or active high inputs, is determined by the state of the programming inputs, PE2 and PE3. For example, if PE2 is held at V_{DD} , E2 functions as an active high enable. If PE2 is held to V_{SS} , E2 functions as an active low chip enable input.

Programmability of E2 and E3 allows four banks of depth expansion to be accomplished with no additional logic. By programming the enable inputs of four ΣRAMs in binary sequence (00, 01, 10, 11) and driving the enable inputs with two address inputs, four ΣRAMs can be made to look like one larger RAM to the system.

Example Four Bank Depth Expansion Schematic—Σ1x2Lp

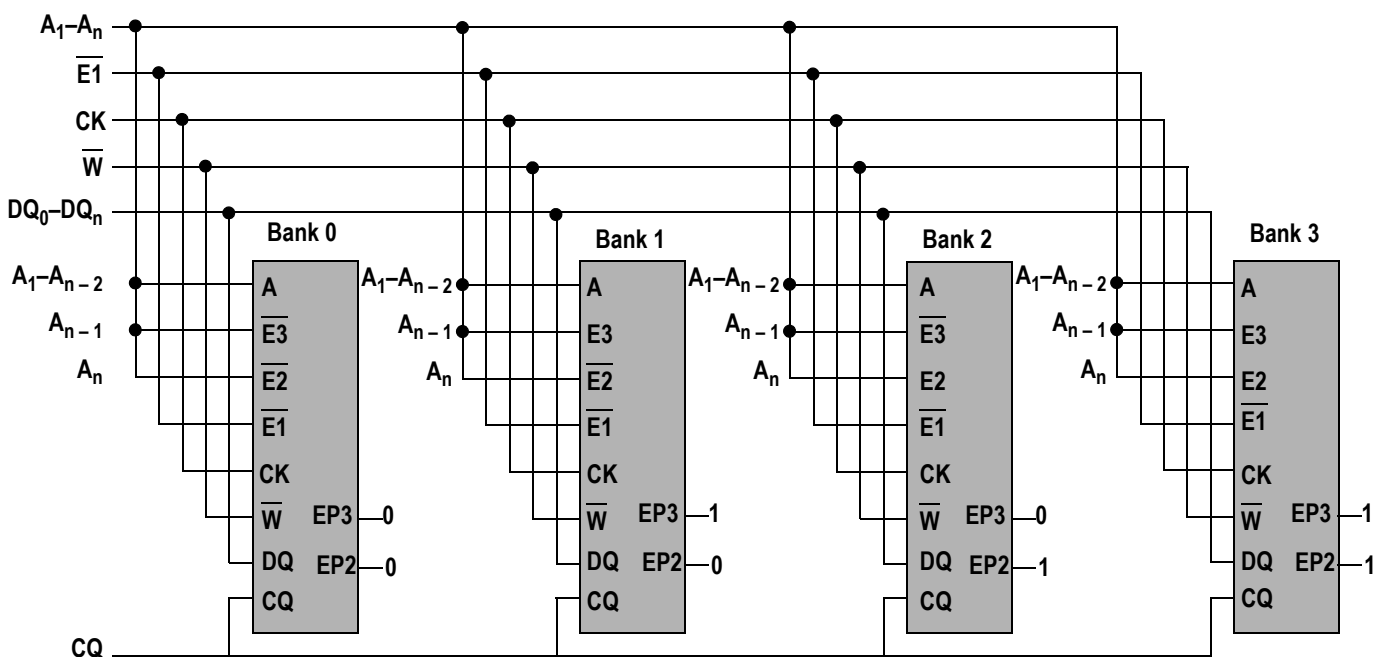

Bank Enable Truth Table

	EP2	EP3	E2	E3
Bank 0	V_{SS}	V_{SS}	Active Low	Active Low
Bank 1	V_{SS}	V_{DD}	Active Low	Active High
Bank 2	V_{DD}	V_{SS}	Active High	Active Low
Bank 3	V_{DD}	V_{DD}	Active High	Active High

Echo Clock Control in Two Banks of SigmaRAM Double Data Rate RAMs

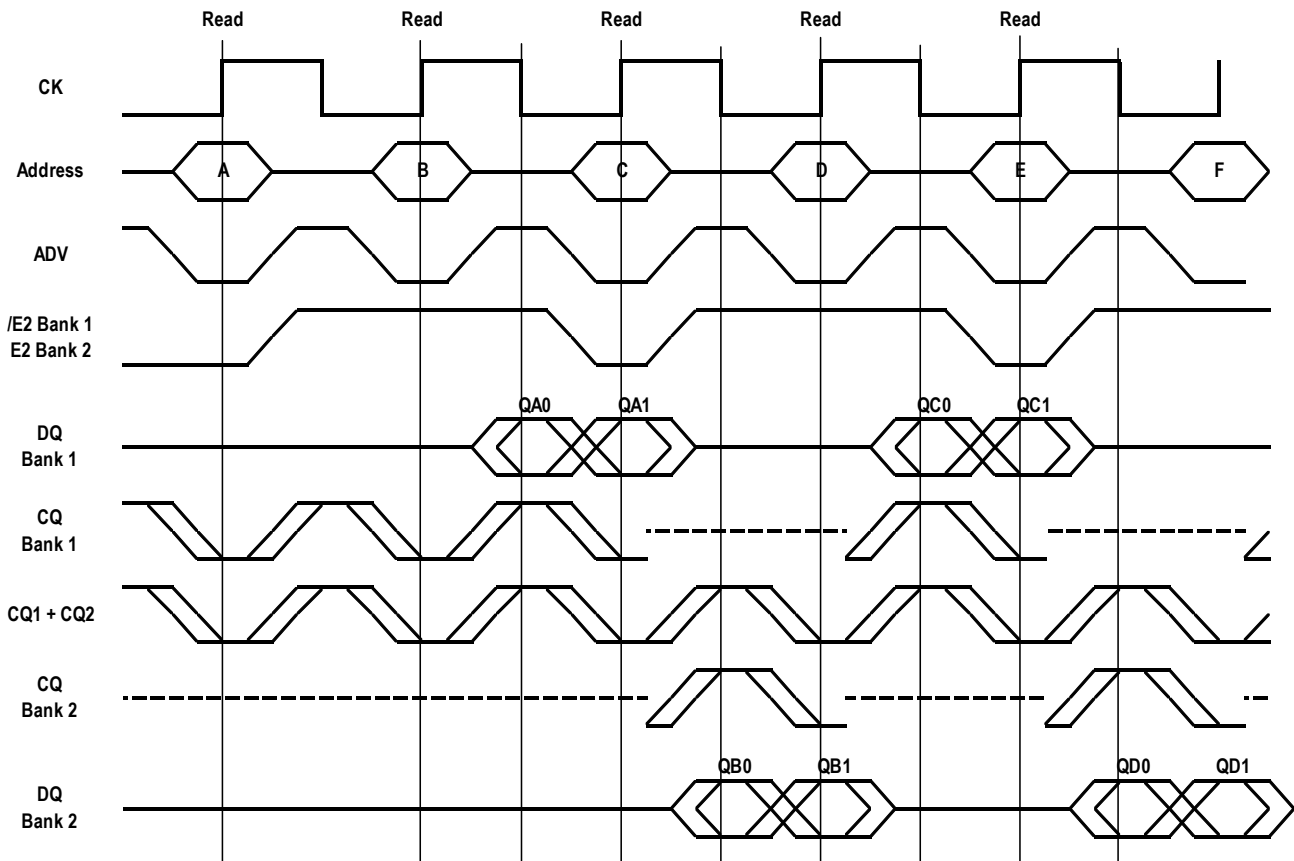

Note: E1\ does not deselect the Echo Clock Outputs. Echo Clock outputs are synchronously deselected by E2 or E3 being sampled false.

It should be noted that deselection of the RAM via E2 and E3 also deselected the Echo Clock output drivers. The deselection of Echo Clock drivers is always pipelined to the same degree as output data. Deselection of the RAM via $\overline{E1}$ does not deactivate the Echo Clocks.

In some applications it may be appropriate to pause between banks; to deselect both RAMs with $\overline{E1}$ before resuming read operations. An $\overline{E1}$ deselection at a bank switch will allow at least one clock to be issued from the new bank before the first read cycle in the bank. Although the following drawing illustrates a $\overline{E1}$ read pause upon switching from Bank 1 to Bank 2, a write to Bank 2 would have the same effect, causing the RAM in Bank 2 to issue at least one clock before it is needed.

SigmaRAM DDR Bank Switch with $\overline{E1}$ Deselect

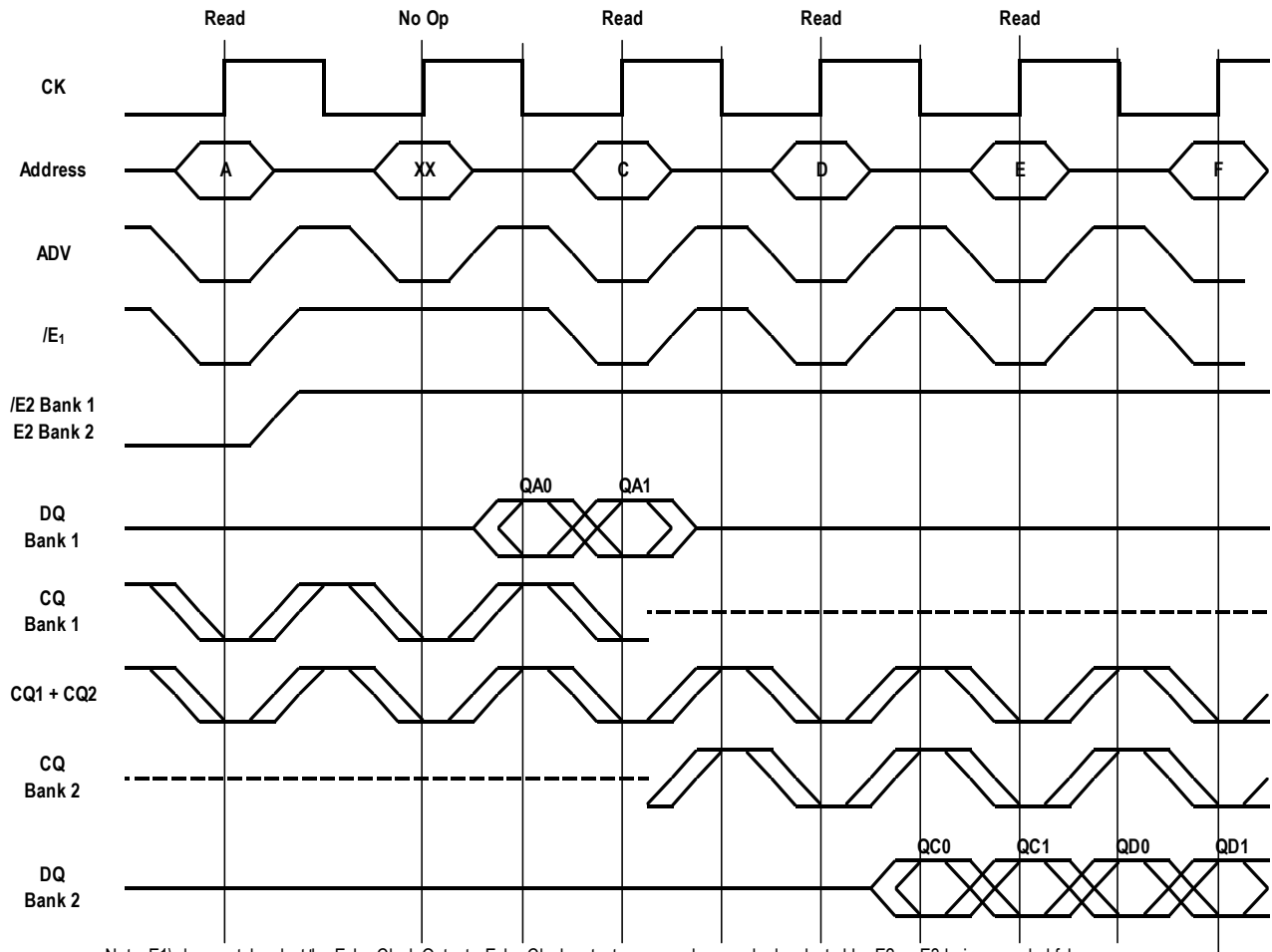

Note: $\overline{E1}$ does not deselect the Echo Clock Outputs. Echo Clock outputs are synchronously deselected by $\overline{E2}$ or $\overline{E3}$ being sampled false.

FLXDrive™ Output Driver Impedance Control

The ZQ pin allows selection between Σ RAM nominal drive strength (ZQ floating or low) for multi-drop bus applications and low drive strength (ZQ high) point-to-point applications. See "Output Driver Characteristics" on page 42 for details.

Late Write, Pipelined Read Truth Table

CK	$\overline{E1}$ (t_n)	E (t_n)	ADV (t_n)	\overline{W} (t_n)	Previous Operation	Current Operation	DQ/CQ (t_n)	DQ/CQ ($t_{n+1/2}$)	DQ/CQ (t_{n+1})	DQ/CQ ($t_{n+1/2}$)
0→1	X	F	0	X	X	Bank Deselect	***		Hi-Z	
0→1	X	X	1	X	Bank Deselect	Bank Deselect (Continue)	Hi-Z		Hi-Z	
0→1	1	T	0	X	X	Deselect	***		Hi-Z/CQ	
0→1	X	X	1	X	Deselect	Deselect (Continue)	Hi-Z/CQ		Hi-Z/CQ	
0→1	0	T	0	0	X	Write Loads new address	***		D1/CQ	D2/CQ
0→1	X	X	1	X	Write	Write Continue Increments address by 2	Dn-2/CQ	Dn-1/CQ	Dn/CQ	Dn+1/CQ
0→1	0	T	0	1	X	Read Loads new address	***		Q1/CQ	Q2/CQ
0→1	X	X	1	X	Read	Read Continue Increments address by 2	Qn-2/CQ	Qn-2/CQ	Qn/CQ	Qn+1/CQ

Notes:

1. If $E2 = EP2$ and $E3 = EP3$ then $E = "T"$ else $E = "F"$.
2. "1" = input "high"; "0" = input "low"; "X" = input "don't care"; "T" = input "true"; "F" = input "false".
3. "***" indicates that the DQ input requirement / output state and CQ output state are determined by the previous operation.
4. DQs are tri-stated in response to Bank Deselect, Chip Deselect, and Write commands, one full cycle after the command is sampled.
5. CQs are tri-stated in response to Bank Deselect commands only, one full cycle after the command is sampled.
6. One (1) Continue operation may be initiated after a Read or Write operation is initiated to burst transfer a total of four (4) distinct pieces of data per single external address input. If a second (2nd) Continue operation is initiated, the internal address wraps back to the initial external (base) address.

Common I/O State Diagram

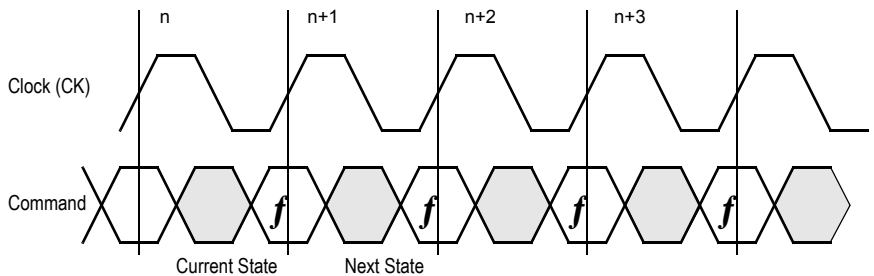
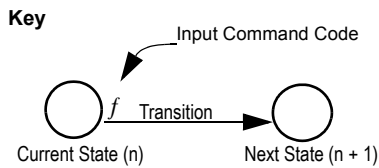
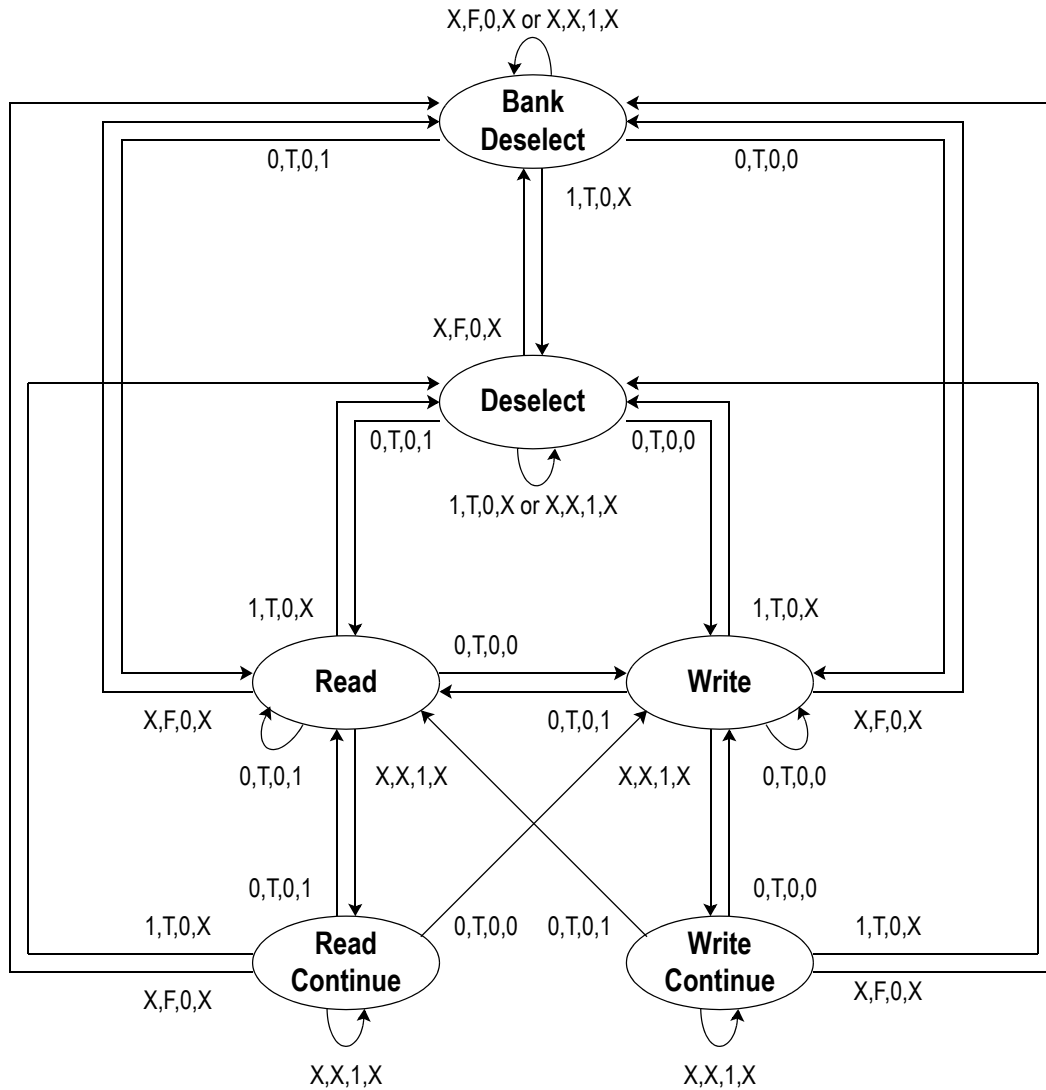

Current State & Next State Definition for Read/Write Control State Diagram

Notes:

1. The notation "X,X,X,X" controlling the state transitions above indicate the states of inputs $\overline{E1}$, E, ADV, and \overline{W} respectively.
2. If (E2 = EP2 and E3 = EP3) then E = "T" else E = "F".
3. "1" = input "high"; "0" = input "low"; "X" = input "don't care"; "T" = input "true"; "F" = input "false".

Absolute Maximum Ratings

(All voltages reference to V_{SS})

Symbol	Description	Value	Unit
V_{DD}	Voltage on V_{DD} Pins	-0.5 to 2.5	V
V_{DDI}	Voltage in V_{DDI} Pins	-0.5 to 2.5	V
V_{DDQ}	Voltage in V_{DDQ} Pins	-0.5 to V_{DD}	V
$V_{I/O}$	Voltage on I/O Pins	-0.5 to $V_{DDQ}+0.5$ (≤ 2.5 V max.)	V
V_{IN}	Voltage on Other Input Pins	-0.5 to $V_{DDI}+0.5$ (≤ 2.5 V max.)	V
I_{IN}	Input Current on Any Pin	+/-100	mA dc
I_{OUT}	Output Current on Any I/O Pin	+/-100	mA dc
T_J	Maximum Junction Temperature	125	°C
T_{STG}	Storage Temperature	-55 to 125	°C

Note:

Permanent damage to the device may occur if the Absolute Maximum Ratings are exceeded. Operation should be restricted to Recommended Operating Conditions. Exposure to conditions exceeding the Recommended Operating Conditions, for an extended period of time, may affect reliability of this component.

Recommended Operating Conditions

Power Supplies

Parameter	Symbol	Min.	Typ.	Max.	Unit	Notes
Supply Voltage	V_{DD}	1.7	1.8	1.95	V	
1.8 V Input Supply Voltage	V_{DDI}	1.7	1.8	V_{DD}	V	1
1.8 V I/O Supply Voltage	V_{DDQ}	1.7	1.8	V_{DD}	V	1
1.5 V Input Supply Voltage	V_{DDI}	1.4	1.5	1.6 V	V	1
1.5 V I/O Supply Voltage	V_{DDQ}	1.4	1.5	1.6 V	V	1
Ambient Temperature (Commercial Range Versions)	T_A	0	25	70	°C	2
Ambient Temperature (Industrial Range Versions)	T_A	-40	25	85	°C	2

Notes:

- Unless otherwise noted, all performance specifications quoted are evaluated for worst case at both $1.4\text{ V} \leq V_{DDQ} \leq 1.6\text{ V}$ (i.e., 1.5 V I/O) and $1.7\text{ V} \leq V_{DDQ} \leq 1.95\text{ V}$ (i.e., 1.8 V I/O) and quoted at whichever condition is worst case.
- Most speed grades and configurations of this device are offered in both Commercial and Industrial Temperature ranges. The part number of Industrial Temperature Range versions end the character "I". Unless otherwise noted, all performance specifications quoted are evaluated for worst case in the temperature range marked on the device.

CMOS I/O DC Input Characteristics

Parameter	Symbol	Min.	Typ.	Max.	Unit	Notes
CMOS Input High Voltage	V_{IH}	$0.65 * V_{DDI}$	—	$V_{DDI} + 0.3$	V	1
CMOS I/O Input High Voltage	V_{IH}	$0.65 * V_{DDI}$	—	$V_{DDI} + 0.3$	V	1
CMOS Input Low Voltage	V_{IL}	-0.3	—	$0.35 * V_{DDI}$	V	1

Note: For devices supplied with CMOS input buffers. Compatible with both 1.8 V and 1.5 V I/O drivers.

Undershoot Measurement and Timing

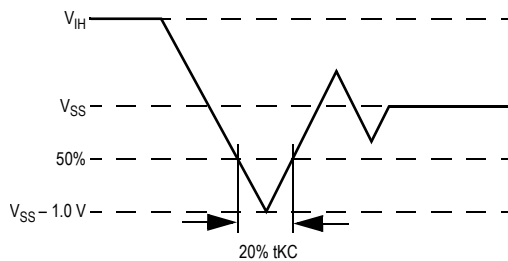

Overshoot Measurement and Timing

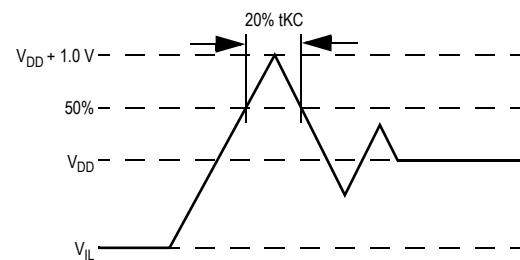

Capacitance

($T_A = 25^\circ\text{C}$, $f = 1$ MHz, $V_{DD} = 1.8$ V)

Parameter	Symbol	Test conditions	Typ.	Max.	Unit
Input Capacitance	C_{IN}	$V_{IN} = 0$ V	4	5	pF
Output Capacitance	C_{OUT}	$V_{OUT} = 0$ V	6	7	pF

Note: This parameter is sample tested.

Package Thermal Characteristics

Rating	Layer Board	Symbol	Max	Unit	Notes
Junction to Ambient (at 200 lfm)	single	$R_{\Theta JA}$	TBD	$^\circ\text{C/W}$	1,2
Junction to Ambient (at 200 lfm)	four	$R_{\Theta JA}$	TBD	$^\circ\text{C/W}$	1,2
Junction to Case (TOP)	n/a	$R_{\Theta JC}$	TBD	$^\circ\text{C/W}$	3

Notes:

- Junction temperature is a function of SRAM power dissipation, package thermal resistance, mounting board temperature, ambient. Temperature air flow, board density, and PCB thermal resistance.
- SCMI G-38-87
- Average thermal resistance between die and top surface, MIL SPEC-883, Method 1012.1

AC Test Conditions

Parameter	Conditions
Input high level	V_{DDQ}
Input low level	0 V
Max. input slew rate	2 V/ns
Input reference level	$V_{DD}/2$
Output reference level	$V_{DDQ}/2$

AC Test Load Diagram

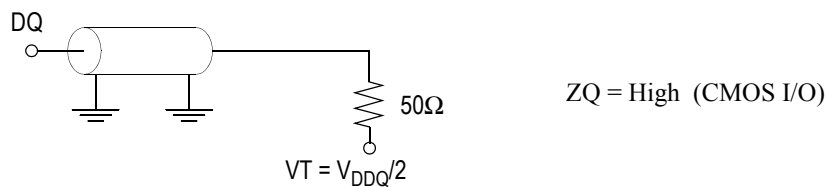

Input and Output Leakage Characteristics

Parameter	Symbol	Test Conditions	Min.	Max	Notes
Input Leakage Current (except mode pins)	I_{IL}	$V_{IN} = 0$ to V_{DD}	-2 μ A	2 μ A	—
Mode and ZQ, MCH, MCL, EP1, EP2 Pin Input Current	I_{INM}	$V_{DD} \geq V_{IN} \geq V_{IL}$ $0 V \leq V_{IN} \leq V_{IL}$	-2 μ A -50 μ A	50 μ A 2 μ A	—
Output Leakage Current	I_{OL}	Output Disable, $V_{OUT} = 0$ to V_{DDQ}	-2 μ A	2 μ A	—

Selectable Impedance Output Driver DC Electrical Characteristics

Parameter	Symbol	Test Conditions	Min.	Max	Notes
Low Drive Output High Voltage	V_{OHL}	$I_{OHL} = -4$ mA	$V_{DDQ} - 0.4$ V	—	1
Low Drive Output Low Voltage	V_{OLL}	$I_{OLL} = 4$ mA	—	0.4 V	1
High Drive Output High Voltage	V_{OHH}	$I_{OHH} = -8$ mA	$V_{DDQ} - 0.4$ V	—	2
High Drive Output Low Voltage	V_{OLH}	$I_{OLH} = 8$ mA	—	0.4 V	2

Notes:

1. ZQ = 1; High Impedance output driver setting
2. ZQ = 0; Low Impedance output driver setting

Operating Currents

Parameter		Symbol	-333		-300		-250		Test Conditions
			0°C to 70°C	-40°C to +85°C	0°C to 70°C	-40°C to +85°C	0°C to 70°C	-40°C to +85°C	
Operating Current	x36	I_{DDP} Pipeline	345 mA	355 mA	320 mA	330 mA	275 mA	285 mA	$\bar{E}1 \leq V_{IL}$ Max. $t_{KHKH} \geq t_{KHKH}$ Min. All other inputs $V_{IL} \geq V_{IN} \geq V_{IH}$
	x18	I_{DDP} Pipeline	245 mA	255 mA	225 mA	235 mA	200 mA	210 mA	
Chip Disable Current	x36	I_{SB1} Pipeline	75 mA	85 mA	70 mA	80 mA	65 mA	75 mA	$\bar{E}1 \geq V_{IH}$ Min. or $t_{KHKH} \geq t_{KHKH}$ Min. All other inputs $V_{IL} \geq V_{IN} \geq V_{IH}$
	x18	I_{SB1} Pipeline	70 mA	80 mA	65 mA	75 mA	60 mA	70 mA	
Bank Deselect Current	x36	I_{SB2} Pipeline	75 mA	85 mA	70 mA	80 mA	65 mA	75 mA	E2 or E3 False $t_{KHKH} \geq t_{KHKH}$ Min. All other inputs $V_{IL} \geq V_{IN} \geq V_{IH}$
	x18	I_{SB2} Pipeline	70 mA	80 mA	65 mA	75 mA	60 mA	70 mA	
CMOS Deselect Current		I_{DD3}	45 mA	55 mA	45 mA	55 mA	45 mA	55 mA	Device Deselected All inputs $V_{SS} + 0.10\text{ V}$ $\geq V_{IN} \geq$ $V_{DD} - 0.10\text{ V}$

AC Electrical Characteristics

Parameter	Symbol	-333		-300		-250		Unit	Notes
		Min	Max	Min	Max	Min	Max		
Clock Cycle Time	tKHKH	3.0	—	3.3	—	4.0	—	ns	—
Clock High Time	tKHKL	1.2	—	1.3	—	1.5	—	ns	—
Clock Low Time	tKCLK	1.2	—	1.3	—	1.5	—	ns	—
Clock High to Echo Clock Low-Z	tKHCX1	0.5	—	0.5	—	0.5	—	ns	2
Clock High to Echo Clock High	tKHCH	0.5	1.5	0.5	1.7	0.5	2.0	ns	—
Echo Clock High Time	tCHCL	tKHKL +/- 100 ps				tKHKL +/- 120 ps		ns	2
Clock Low to Echo Clock Low	tKLCL	0.5	1.5	0.5	1.7	0.5	2.0	ns	—
Echo Clock Low Time	tCLCH	tKCLK +/- 100 ps				tKCLK +/- 120 ps		ns	2
Clock High to Echo Clock High-Z	tKHCZ	0.5	1.5	0.5	1.7	0.5	2.0	ns	1, 2
Clock High to Output in Low-Z	tKHQX1	0.5	—	0.5	—	0.5	—	ns	1
Clock High to Output Valid	tKHQV	—	1.6	—	1.8	—	2.1	ns	—
Clock Low to Output Invalid	tKLQX	—	1.6	—	1.8	—	2.1	ns	—
Clock Low to Output Valid	tKLQV	0.5	—	0.5	—	0.5	—	ns	—
Clock High to Output Invalid	tKHQX	0.5	—	0.5	—	0.5	—	ns	—
Clock High to Output in High-Z	tKHQZ	0.5	1.6	0.5	1.8	0.5	2.1	ns	1
Echo Clock High to Output Valid	tCHQV	—	0.2	—	0.2	—	0.25	ns	2
Echo Clock Low to Output Invalid	tCLQX	-0.2	—	-0.2	—	-0.25	—	ns	2
Echo Clock Low to Output Valid	tCLQV	—	0.2	—	0.2	—	0.25	ns	2
Echo Clock High to Output Invalid	tCHQX	-0.2	—	-0.2	—	-0.25	—	ns	2
Address Valid to Clock High	tAVKH	0.6	—	0.7	—	0.8	—	ns	—
Clock High to Address Don't Care	tKHAX	0.4	—	0.4	—	0.5	—	ns	—
Enable Valid to Clock High	tEVKH	0.6	—	0.7	—	0.8	—	ns	—
Clock High to Enable Don't Care	tKHEX	0.4	—	0.4	—	0.5	—	ns	—
Write Valid to Clock High	tWVKH	0.6	—	0.7	—	0.8	—	ns	—
Clock High to Write Don't Care	tKHWX	0.4	—	0.4	—	0.5	—	ns	—
Clock High to Byte Write Don't Care	tKHBX	0.4	—	0.4	—	0.5	—	ns	—
Data In Valid to Clock High	tDVKH	0.32	—	0.35	—	0.40	—	ns	—
Clock High to Data In Don't Care	tKHDX	0.27	—	0.30	—	0.35	—	ns	—

Notes:

1. Measured at 100 mV from steady state. Not 100% tested.
2. Guaranteed by design. Not 100% tested.
3. For any specific temperature and voltage tKHCZ < tKHCX1.

Parameter	Symbol	-333		-300		-250		Unit	Notes
		Min	Max	Min	Max	Min	Max		
Data In Valid to Clock Low	tDVKL	0.32	—	0.35	—	0.40	—	ns	
Clock Low to Data In Don't Care	tKLDX	0.27	—	0.30	—	0.35	—	ns	
ADV Valid to Clock High	tadvVKH	0.6	—	0.7	—	0.8	—	ns	—
Clock High to ADV Don't Care	tKHadvX	0.4	—	0.4	—	0.5	—	ns	—

Notes:

1. Measured at 100 mV from steady state. Not 100% tested.
2. Guaranteed by design. Not 100% tested.
3. For any specific temperature and voltage $tKHCZ < tKHCX1$.

Timing Parameter Key—Read Cycle Timing

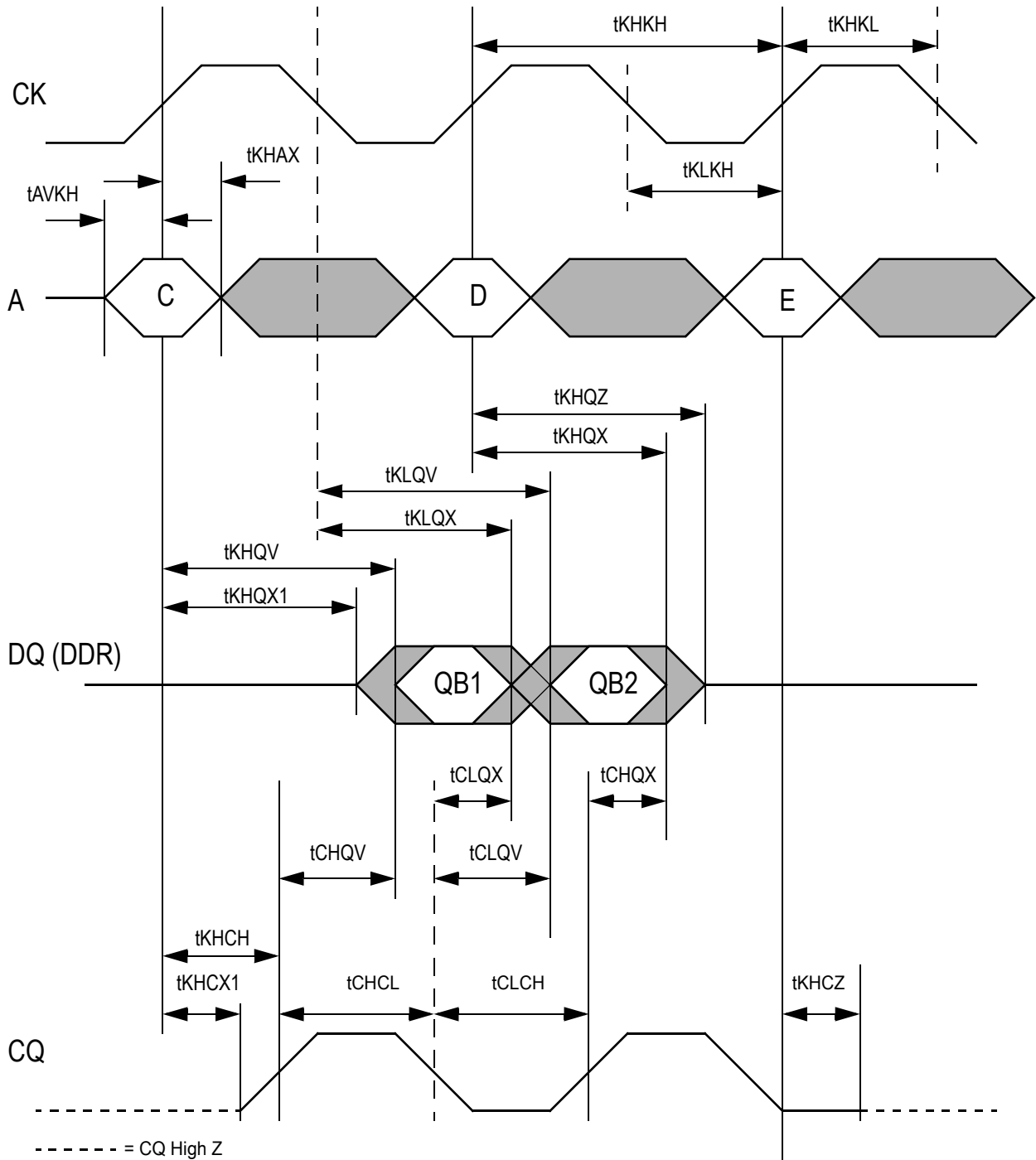

Timing Parameter Key—Control and Data In Timing

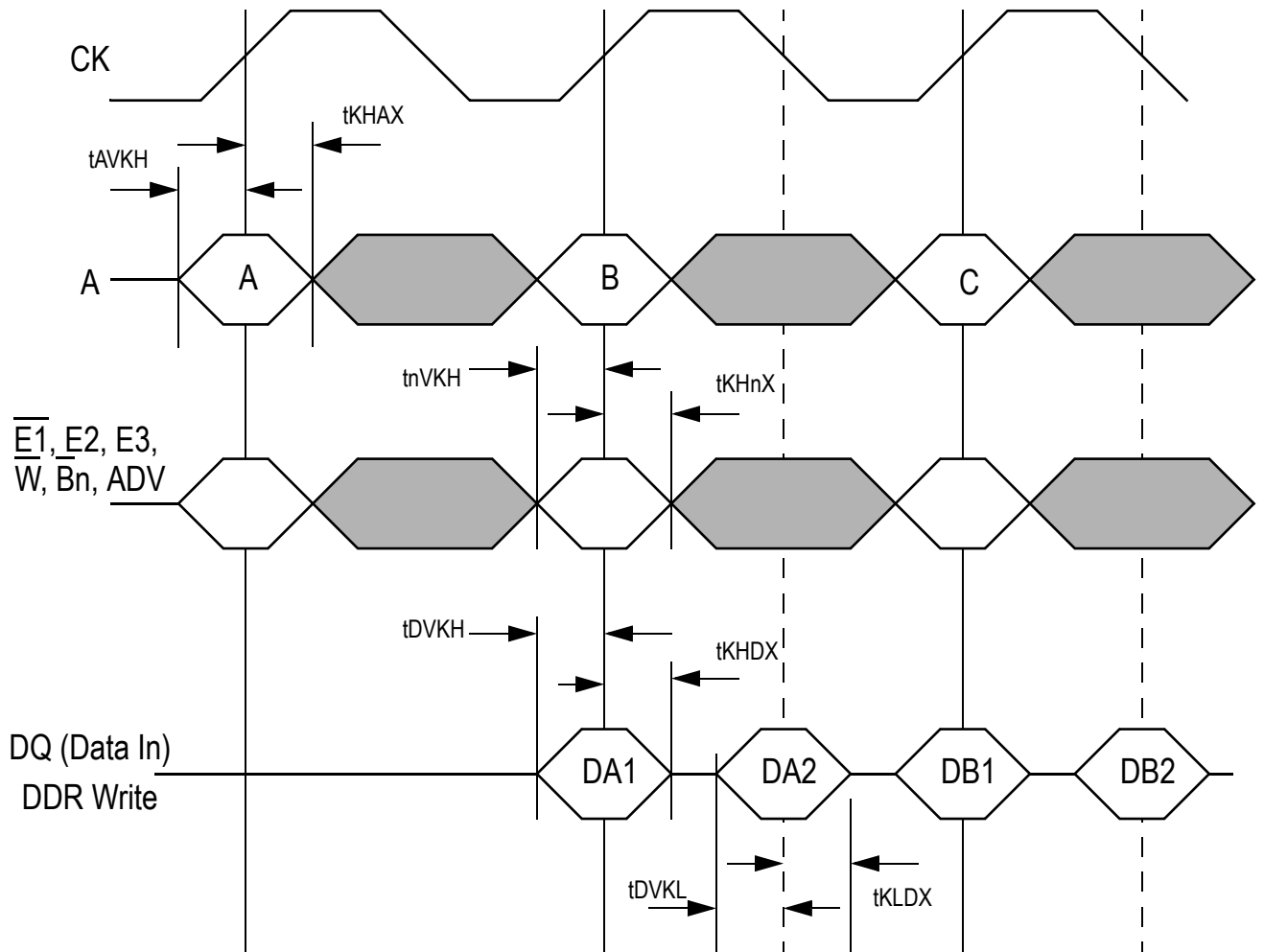

Note: $t_{nVKH} = t_{EVKH}, t_{WVKH}, t_{BVKH}, \text{etc.}$ and $t_{KHnX} = t_{KHEx}, t_{KHwX}, t_{KHbX}, \text{etc.}$

JTAG Port Operation

Overview

The JTAG Port on this RAM operates in a manner that is compliant with IEEE Standard 1149.1-1990, a serial boundary scan interface standard (commonly referred to as JTAG). The JTAG Port input interface levels scale with V_{DDI} . The JTAG output drivers are powered by V_{DDQ} .

Disabling the JTAG Port

It is possible to use this device without utilizing the JTAG port. The port is reset at power-up and will remain inactive unless clocked. To assure normal operation of the RAM with the JTAG Port unused, TCK, TDI, and TMS may be left floating or tied to V_{DDI} . TDO should be left unconnected.

JTAG Pin Descriptions

Pin	Pin Name	I/O	Description
TCK	Test Clock	In	Clocks all TAP events. All inputs are captured on the rising edge of TCK and all outputs propagate from the falling edge of TCK.
TMS	Test Mode Select	In	The TMS input is sampled on the rising edge of TCK. This is the command input for the TAP controller state machine. An undriven TMS input will produce the same result as a logic one input level.
TDI	Test Data In	In	The TDI input is sampled on the rising edge of TCK. This is the input side of the serial registers placed between TDI and TDO. The register placed between TDI and TDO is determined by the state of the TAP Controller state machine and the instruction that is currently loaded in the TAP Instruction Register (refer to the TAP Controller State Diagram). An undriven TDI pin will produce the same result as a logic one input level.
TDO	Test Data Out	Out	Output that is active depending on the state of the TAP state machine. Output changes in response to the falling edge of TCK. This is the output side of the serial registers placed between TDI and TDO.

Note:

This device does not have a TRST (TAP Reset) pin. TRST is optional in IEEE 1149.1. The Test-Logic-Reset state is entered while TMS is held high for five rising edges of TCK. The TAP Controller is also reset automatically at power-up.

JTAG Port Registers

Overview

The various JTAG registers, referred to as Test Access Port or TAP Registers, are selected (one at a time) via the sequences of 1s and 0s applied to TMS as TCK is strobed. Each of the TAP registers are serial shift registers that capture serial input data on the rising edge of TCK and push serial data out on the next falling edge of TCK. When a register is selected, it is placed between the TDI and TDO pins.

Instruction Register

The Instruction Register holds the instructions that are executed by the TAP controller when it is moved into the Run, Test/Idle, or the various data register states. Instructions are 3 bits long. The Instruction Register can be loaded when it is placed between the TDI and TDO pins. The Instruction Register is automatically preloaded with the IDCODE instruction at power-up or whenever the controller is placed in Test-Logic-Reset state.

Bypass Register

The Bypass Register is a single-bit register that can be placed between TDI and TDO. It allows serial test data to be passed through the RAM's JTAG Port to another device in the scan chain with as little delay as possible.

Boundary Scan Register

The Boundary Scan Register is a collection of flip flops that can be preset by the logic level found on the RAM's input or I/O pins. The flip flops are then daisy chained together so the levels found can be shifted serially out of the JTAG Port's TDO pin. The Boundary Scan Register also includes a number of place holder flip flops (always set to a logic 1). The relationship between the device pins and the bits in the Boundary Scan Register is described in the Scan Order Table following. The Boundary Scan Register, under the control of the TAP Controller, is loaded with the contents of the RAMs I/O ring when the controller is in Capture-DR state and then is placed between the TDI and TDO pins when the controller is moved to Shift-DR state. SAMPLE-Z, SAMPLE/PRELOAD and EXTEST instructions can be used to activate the Boundary Scan Register.

JTAG TAP Block Diagram

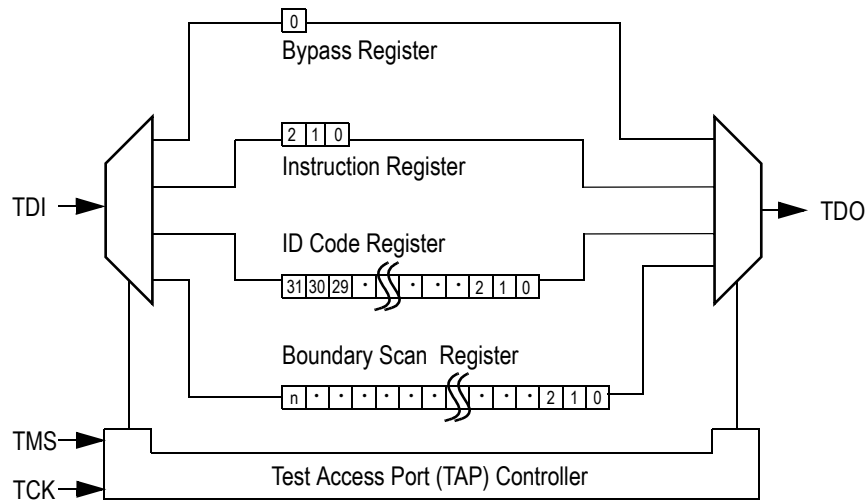

Identification (ID) Register

The ID Register is a 32-bit register that is loaded with a device and vendor specific 32-bit code when the controller is put in Capture-DR state with the IDCODE command loaded in the Instruction Register. The code is loaded from a 32-bit on-chip ROM. It describes various attributes of the RAM as indicated below. The register is then placed between the TDI and TDO pins when the controller is moved into Shift-DR state. Bit 0 in the register is the LSB and the first to reach TDO when shifting begins.

ID Register Contents

Bit #	Die Revision Code				Not Used													I/O Configuration				GSI Technology JEDEC Vendor ID Code								Presence Register		
	31	30	29	28	27	26	25	24	23	22	21	20	19	18	17	16	15	14	13	12	11	10	9	8	7	6	5	4	3		2	1
x36	0	0	0	0	0	0	0	0	0	0	0	0	0	0	0	1	1	0	0	0	0	0	0	1	1	0	1	1	0	0	1	1
x18	0	0	0	0	0	0	0	0	0	0	0	0	0	0	0	1	1	0	1	0	0	0	0	1	1	0	1	1	1	0	0	1

Tap Controller Instruction Set

Overview

There are two classes of instructions defined in the Standard 1149.1-1990; standard (Public) instructions, and device specific (Private) instructions. Some Public instructions are mandatory for 1149.1 compliance. Optional Public instructions must be implemented in prescribed ways. The TAP on this device may be used to monitor all input and I/O pads. This device will not perform INTEST but can perform the preload portion of the SAMPLE/PRELOAD command.

When the TAP controller is placed in Capture-IR state, the two least significant bits of the instruction register are loaded with 01. When the controller is moved to the Shift-IR state, the Instruction Register is placed between TDI and TDO. In this state the desired instruction is serially loaded through the TDI input (while the previous contents are shifted out at TDO). For all instructions, the TAP executes newly loaded instructions only when the controller is moved to Update-IR state. The TAP instruction set for this device is listed in the following table.

JTAG Tap Controller State Diagram

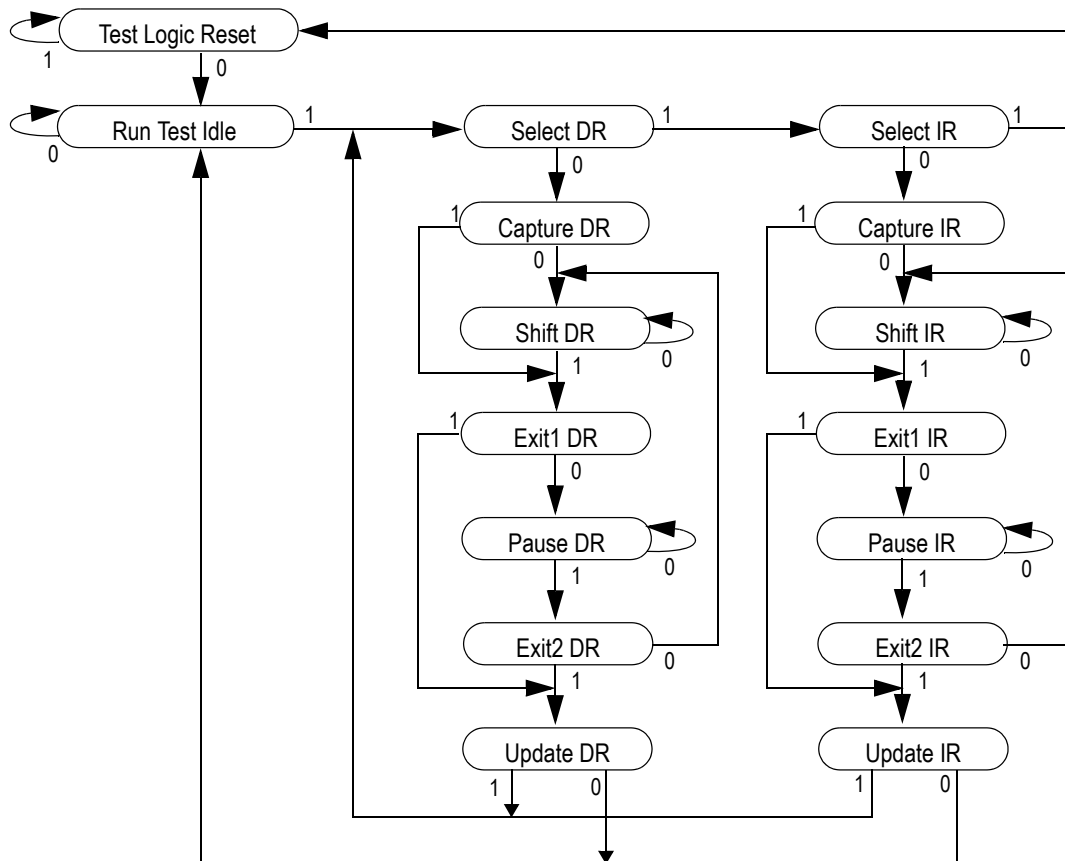

Instruction Descriptions

BYPASS

When the BYPASS instruction is loaded in the Instruction Register, the Bypass Register is placed between TDI and TDO. This occurs when the TAP controller is moved to the Shift-DR state. This allows the board level scan path to be shortened to facilitate testing of other devices in the scan path.

SAMPLE/PRELOAD

SAMPLE/PRELOAD is a Standard 1149.1 mandatory public instruction. When the SAMPLE / PRELOAD instruction is loaded in the Instruction Register, moving the TAP controller into the Capture-DR state loads the data in the RAMs input and I/O buffers into the Boundary Scan Register. Some Boundary Scan Register locations are not associated with an input or I/O pin, and are loaded with the default state identified in the BSD file. Because the RAM clock is independent from the TAP Clock (TCK) it is possible for the TAP to attempt to capture the I/O ring contents while the input buffers are in transition (i.e. in a metastable state). Although allowing the TAP to sample metastable inputs will not harm the device, repeatable results cannot be expected. RAM input signals must be stabilized for long enough to meet the TAP's input data capture set-up plus hold time (tTS plus tTH). The RAM's clock inputs need not be paused for any other TAP operation except capturing

the I/O ring contents into the Boundary Scan Register. Moving the controller to Shift-DR state then places the Boundary Scan Register between the TDI and TDO pins. The Update-DR controller state transfers the contents of boundary scan cells into the holding register of each cell associated with an output pin on the RAM.

EXTEST

EXTEST is an IEEE 1149.1 mandatory public instruction. It is to be executed whenever the instruction register is loaded with all logic 0s. The EXTEST command does not block or override the RAM's input pins (except CK); therefore, the RAM's internal state is still determined by its input pins.

Typically, the Boundary Scan Register is loaded with the desired pattern of data with the SAMPLE/PRELOAD command. Then the EXTEST command is used to output the Boundary Scan Register's contents, in parallel, on the RAM's data output drivers on the falling edge of TCK when the controller is in the Update-IR state.

Alternately, the Boundary Scan Register may be loaded in parallel using the EXTEST command. When the EXTEST instruction is selected, the state of all the RAM's input and I/O pins, as well as the default values at Scan Register locations not associated with a pin, are sampled and transferred in parallel into the Boundary Scan Register on the rising edge of TCK in the Capture-DR state. Boundary Scan Register contents may then be shifted serially through the register using the Shift-DR command or the controller can be skipped to the Update-DR command. When the controller is placed in the Update-DR state, a RAM that has a fully compliant EXTEST function drives out the value of the Boundary Scan Register location associated with which each output pin.

IDCODE

The IDCODE instruction causes the ID ROM to be loaded into the ID register when the controller is in Capture-DR mode and places the ID register between the TDI and TDO pins in Shift-DR mode. The IDCODE instruction is the default instruction loaded in at power up and any time the controller is placed in the Test-Logic-Reset state.

SAMPLE-Z/PRELOAD

The SAMPLE-Z instruction operates exactly like SAMPLE/PRELOAD except that loading the SAMPLE-Z instruction forces all the RAM's output drivers, except TDO, to an inactive drive state (high-Z).

RFU

These instructions are reserved for future use.

JTAG TAP Instruction Set Summary

Instruction	Code	Description	Notes
EXTEST	000	Places the Boundary Scan Register between TDI and TDO.	1
IDCODE	001	Preloads ID Register and places it between TDI and TDO.	1, 2
SAMPLE-Z/ PRELOAD	010	Captures I/O ring contents. Places the Boundary Scan Register between TDI and TDO. Forces all Data and Clock output drivers to High-Z.	1
Private	011	Private instruction.	1
SAMPLE/ PRELOAD	100	Captures I/O ring contents. Places the Boundary Scan Register between TDI and TDO.	1
Private	101	Private instruction.	1
Private	110	Private instruction.	1
BYPASS	111	Places Bypass Register between TDI and TDO.	1

Notes:

1. Instruction codes expressed in binary, MSB on left, LSB on right.
2. Default instruction automatically loaded at power-up and in Test-Logic-Reset state.

JTAG Port Recommended Operating Conditions and DC Characteristics

Parameter	Symbol	Min.	Max.	Unit	Notes
Test Port Input High Voltage	V_{IHT}	$0.65 * V_{DD}$	$V_{DD}+0.3$	V	1
Test Port Input Low Voltage	V_{ILT}	-0.3	$0.35 * V_{DD}$	V	1
TMS, TCK and TDI Input Leakage Current	I_{INTH}	-2	2	uA	2
TMS, TCK and TDI Input Leakage Current	I_{INTL}	-50	2	uA	3
TDO Output Leakage Current	I_{OLT}	-2	2	uA	4
Test Port Output High Voltage	V_{OHT}	$V_{DD} - 100 \text{ mV}$	—	V	5, 6
Test Port Output Low Voltage	V_{OLT}	—	100 mV	V	7

Notes:

1. Input Under/overshoot voltage must be $-1 \text{ V} < V_i < V_{DD} + 1 \text{ V}$ with a pulse width not to exceed 20% t_{TKC} .
2. $V_{DDI} \geq V_{IN} \geq V_{IL}$
3. $0 \text{ V} \leq V_{IN} \leq V_{IL}$
4. Output Disable, $V_{OUT} = 0$ to V_{DDI}
5. The TDO output driver is served by the V_{DDQ} supply.
6. $I_{OH} = -100 \text{ uA}$
7. $I_{OL} = +100 \text{ uA}$

JTAG Port AC Test Conditions

Parameter	Conditions
Input high level	$V_{DDI} - 200\text{ mV}$
Input low level	200 mV
Input slew rate	1 V/ns
Input reference level	$V_{DDI}/2$
Output reference level	$V_{DDQ}/2$

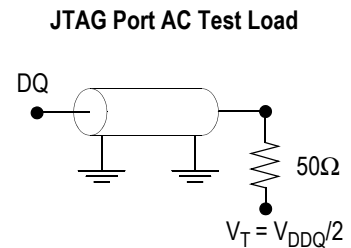

Notes:

1. Include scope and jig capacitance.
2. Test conditions as as shown unless otherwise noted.

JTAG Port Timing Diagram

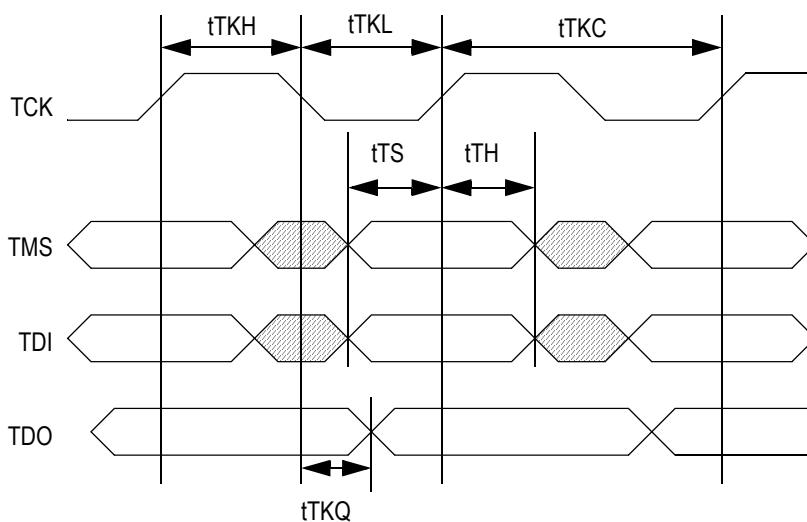

JTAG Port AC Electrical Characteristics

Parameter	Symbol	Min	Max	Unit
TCK Cycle Time	tTKC	50	—	ns
TCK Low to TDO Valid	tTKQ	—	10	ns
TCK High Pulse Width	tTKH	20	—	ns
TCK Low Pulse Width	tTKL	20	—	ns
TDI & TMS Set Up Time	tTS	5	—	ns
TDI & TMS Hold Time	tTH	5	—	ns

209 BGA Package Drawing

14 mm x 22 mm Body, 1.0 mm Bump Pitch, 11 x 19 Bump Array

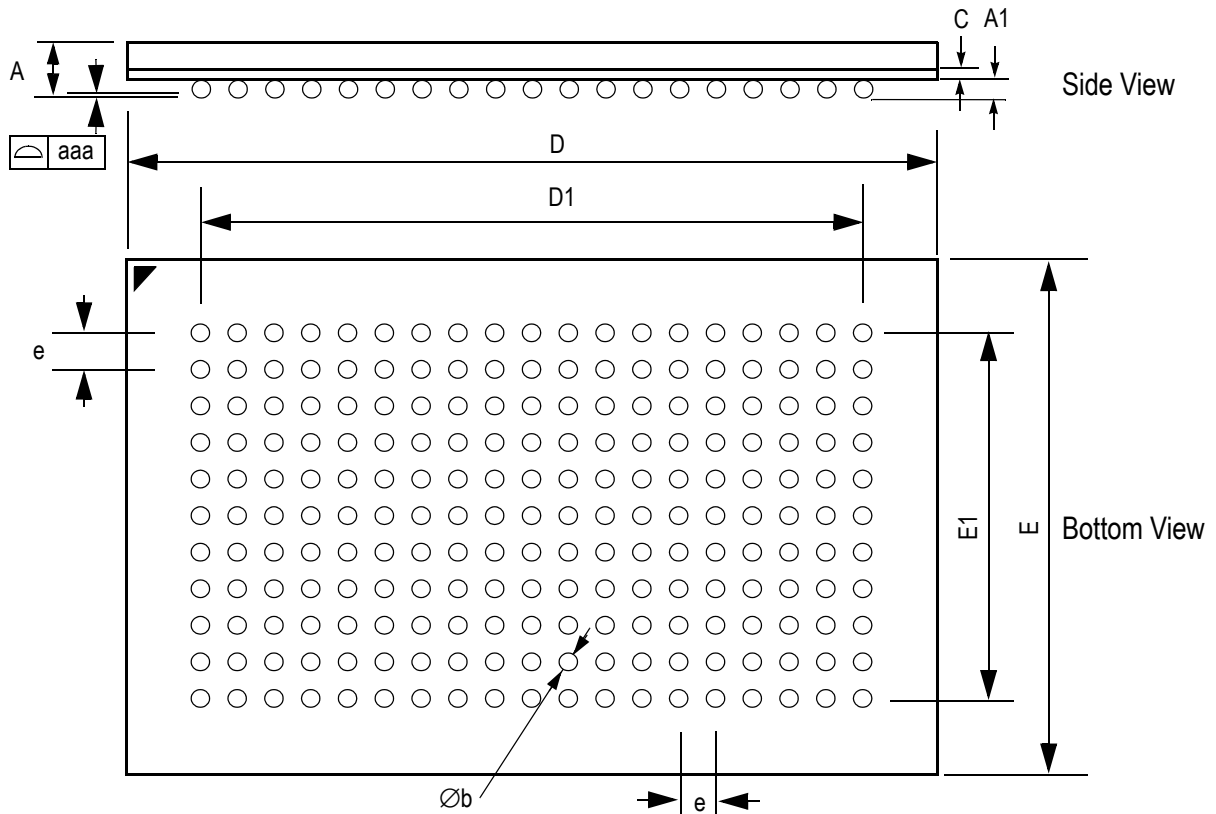

Symbol	Min	Typ	Max	Units
A			1.70	mm
A1	0.40	0.50	0.60	mm
$\varnothing b$	0.50	0.60	0.70	mm
c	0.31	0.36	0.38	mm
D	21.9	22.0	22.1	mm
D1		18.0 (BSC)		mm
E	13.9	14.0	14.1	mm
E1		10.0 (BSC)		mm
e		1.00 (BSC)		mm
aaa		0.15		mm
Rev 1.0				

Ordering Information—GSI SigmaRAM

Org	Part Number ¹	Type	Package	Speed (MHz)	T _A ³
512K x 36	GS8170DD36C-333	Σ1x2Lp DDR ΣRAM	1 mm Pitch, 209-Pin BGA	333	C
512K x 36	GS8170DD36C-300	Σ1x2Lp DDR ΣRAM	1 mm Pitch, 209-Pin BGA	300	C
512K x 36	GS8170DD36C-250	Σ1x2Lp DDR ΣRAM	1 mm Pitch, 209-Pin BGA	250	C
512K x 36	GS8170DD36C-333I	Σ1x2Lp DDR ΣRAM	1 mm Pitch, 209-Pin BGA	333	I
512K x 36	GS8170DD36C-300I	Σ1x2Lp DDR ΣRAM	1 mm Pitch, 209-Pin BGA	300	I
512K x 36	GS8170DD36C-250I	Σ1x2Lp DDR ΣRAM	1 mm Pitch, 209-Pin BGA	250	I
1Mx 18	GS8170DD18C-333	Σ1x2Lp DDR ΣRAM	1 mm Pitch, 209-Pin BGA	333	C
1Mx 18	GS8170DD18C-300	Σ1x2Lp DDR ΣRAM	1 mm Pitch, 209-Pin BGA	300	C
1Mx 18	GS8170DD18C-250	Σ1x2Lp DDR ΣRAM	1 mm Pitch, 209-Pin BGA	250	C
1Mx 18	GS8170DD18C-333I	Σ1x2Lp DDR ΣRAM	1 mm Pitch, 209-Pin BGA	333	I
1Mx 18	GS8170DD18C-300I	Σ1x2Lp DDR ΣRAM	1 mm Pitch, 209-Pin BGA	300	I
1Mx 18	GS8170DD18C-250I	Σ1x2Lp DDR ΣRAM	1 mm Pitch, 209-Pin BGA	250	I

Notes:

1. Customers requiring delivery in Tape and Reel should add the character “T” to the end of the part number. Example: GS817x18C-300T.
2. T_A = C = Commercial Temperature Range. T_A = I = Industrial Temperature Range.