

TQFP Commercial Temp Industrial Temp	256K x 18, 128K x 32, 128K x 36 4Mb Sync Burst SRAMs	8 ns–12 ns 3.3 V V_{DD} 3.3 V and 2.5 V I/O
---	---	--

Features

- Flow Through mode operation
- 3.3 V +10%/–5% core power supply
- 2.5 V or 3.3 V I/O supply
- $\overline{\text{LBO}}$ pin for Linear or Interleaved Burst mode
- Internal input resistors on mode pins allow floating mode pins
- Default to Interleaved Pipelined mode
- Byte Write ($\overline{\text{BW}}$) and/or Global Write ($\overline{\text{GW}}$) operation
- Common data inputs and data outputs
- Clock Control, registered, address, data, and control
- Internal self-timed write cycle
- Automatic power-down for portable applications
- JEDEC standard 100-lead TQFP

		-8	-8.5	-10	-12	Unit
Flow	tkQ	8	8.5	10	12	ns
Through	tCycle	9.1	10	10	15	ns
2-1-1-1	I _{DD}	115	105	105	80	mA

Functional Description

Applications

The GS840F18/32/36A is a 4,718,592-bit (4,194,304-bit for x32 version) high performance synchronous SRAM with a 2-bit burst address counter. Although of a type originally developed for Level 2 Cache applications supporting high performance CPUs, the device now finds application in synchronous SRAM applications, ranging from DSP main store to networking chip set support. The GS840F18/32/36A is available in a JEDEC standard 100-lead TQFP package.

Controls

Addresses, data I/Os, chip enables ($\overline{\text{E}}_1, \text{E}_2, \overline{\text{E}}_3$), address burst control inputs ($\overline{\text{ADSP}}, \overline{\text{ADSC}}, \overline{\text{ADV}}$) and write control inputs ($\overline{\text{Bx}}, \overline{\text{BW}}, \overline{\text{GW}}$) are synchronous and are controlled by a positive-edge-triggered clock input (CK). Output enable ($\overline{\text{G}}$) and power down control (ZZ) are asynchronous inputs. Burst cycles can be initiated with either $\overline{\text{ADSP}}$ or $\overline{\text{ADSC}}$ inputs. In Burst mode, subsequent burst addresses are generated internally and are controlled by $\overline{\text{ADV}}$. The burst address counter may be configured to count in either linear or interleave order with the Linear Burst Order ($\overline{\text{LBO}}$) input. The Burst function need not be used. New addresses can be loaded on every cycle with no degradation of chip performance.

Designing For Compatibility

The JEDEC Standard for Burst RAMS calls for a $\overline{\text{FT}}$ mode pin option (pin 14 on TQFP). Board sites for Flow Through Burst RAMS should be designed with V_{SS} connected to the $\overline{\text{FT}}$ pin location to ensure the broadest access to multiple vendor sources. Boards designed with $\overline{\text{FT}}$ pin pads tied low may be stuffed with GSI's Pipeline/Flow Through-configurable Burst RAMS or any vendor's Flow Through or configurable Burst SRAM. Bumps designed with the $\overline{\text{FT}}$ pin location tied high or floating must employ a non-configurable Flow Through Burst RAM, like this RAM, to achieve flow through functionality.

Byte Write and Global Write

Byte write operation is performed by using Byte Write enable ($\overline{\text{BW}}$) input combined with one or more individual byte write signals ($\overline{\text{Bx}}$). In addition, Global Write ($\overline{\text{GW}}$) is available for writing all bytes at one time, regardless of the Byte Write control inputs.

Sleep Mode

Low power (Sleep mode) is attained through the assertion (high) of the ZZ signal, or by stopping the clock (CK). Memory data is retained during Sleep mode.

Core and Interface Voltages

The GS840F18/32/36A operates on a 3.3 V power supply and all inputs/outputs are 3.3 V- and 2.5 V-compatible. Separate output power (V_{DDQ}) pins are used to decouple output noise from the internal circuit.

GS840F18A 100-Pin TQFP Pinout

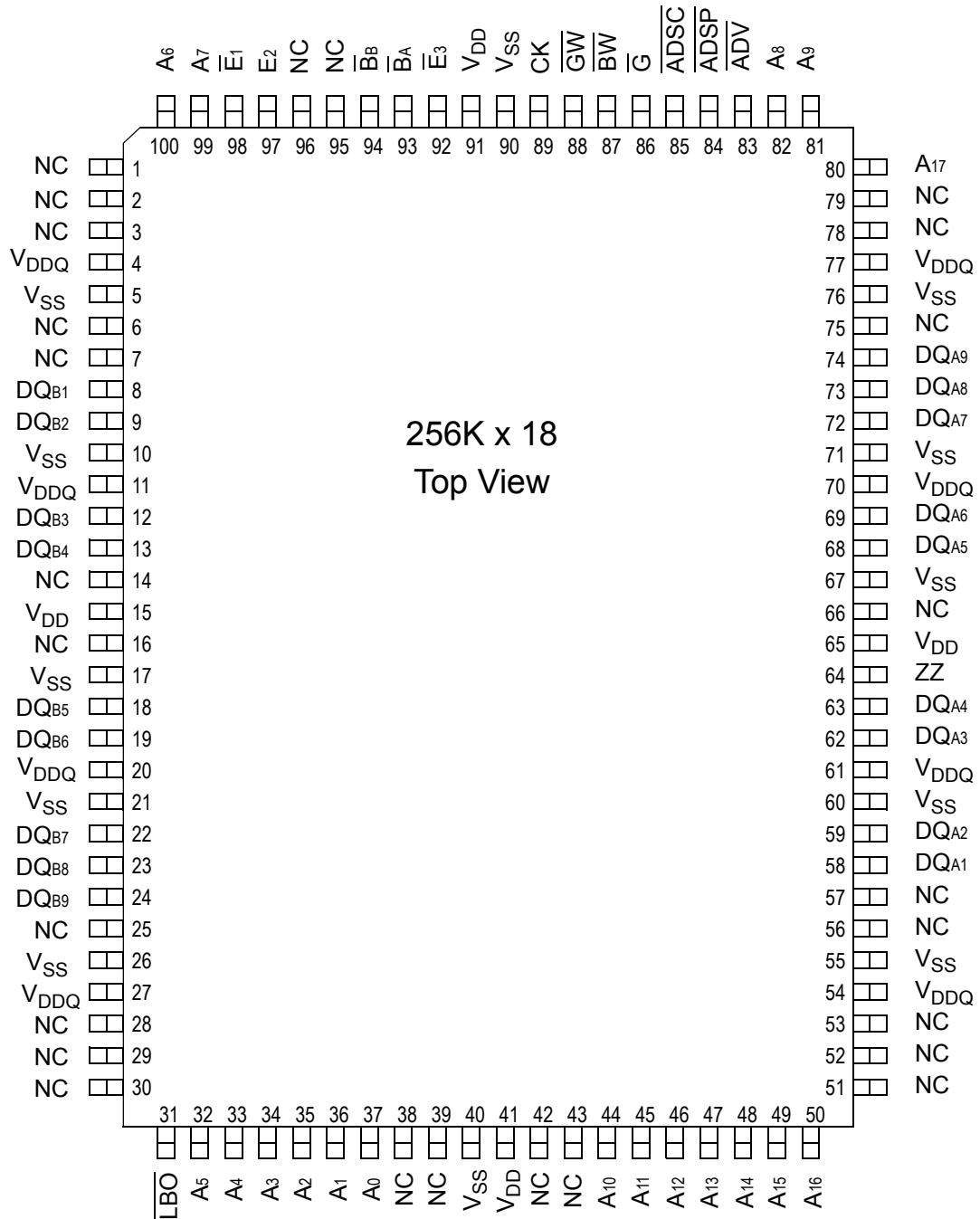

GS840F32A 100-Pin TQFP Pinout

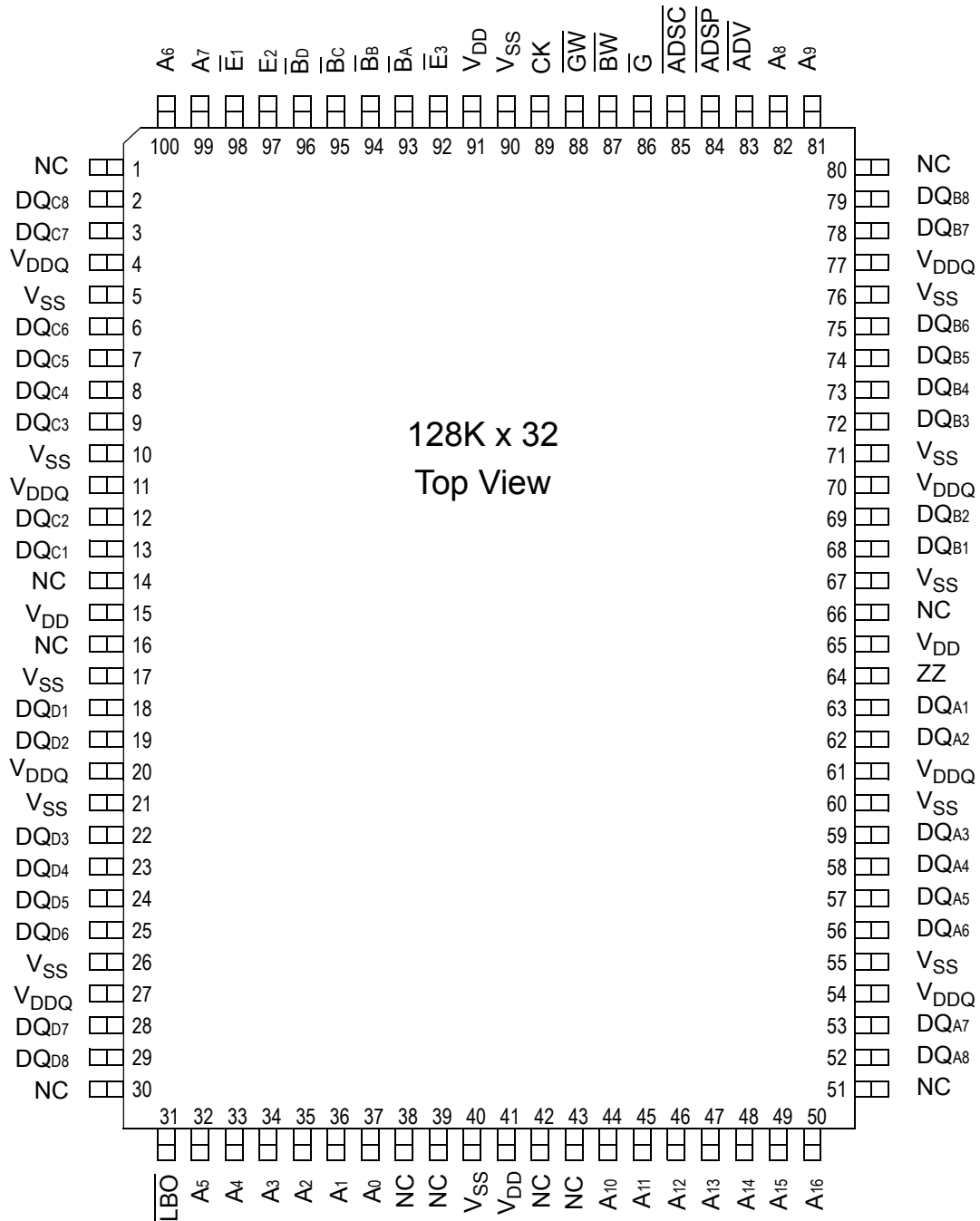

GS840F36A 100-Pin TQFP Pinout

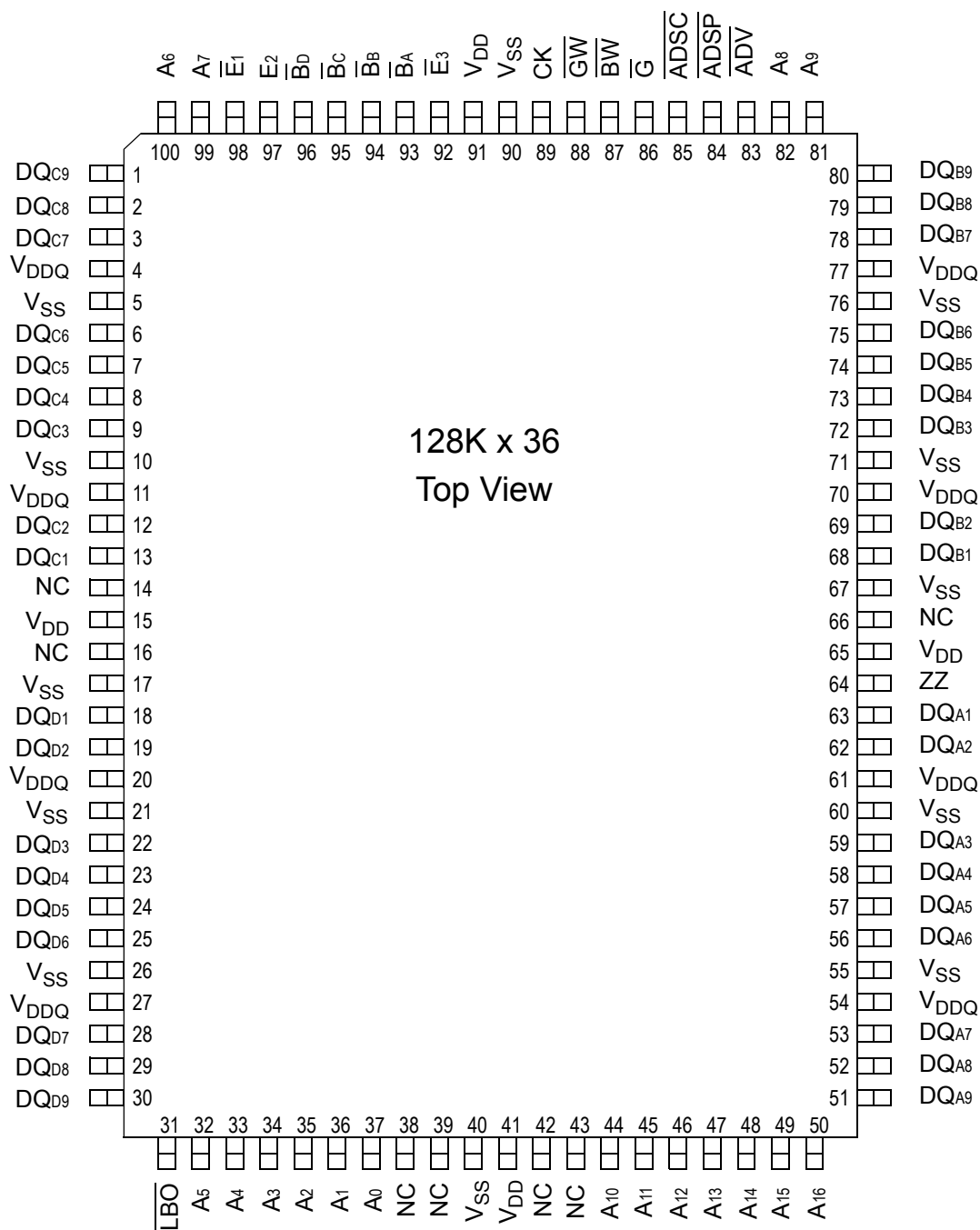

TQFP Pin Description

Pin Location	Symbol	Type	Description
37, 36	A ₀ , A ₁	I	Address field LSBs and Address Counter preset Inputs
35, 34, 33, 32, 100, 99, 82, 81, 44, 45, 46, 47, 48, 49, 50	A ₂ –A ₁₆	I	Address Inputs
80	A ₁₇	I	Address Inputs (x18 versions)
52, 53, 56, 57, 58, 59, 62, 63 68, 69, 72, 73, 74, 75, 78, 79 2, 3, 6, 7, 8, 9, 12, 13 18, 19, 22, 23, 24, 25, 28, 29	DQ _{A1} –DQ _{A8} DQ _{B1} –DQ _{B8} DQ _{C1} –DQ _{C8} DQ _{D1} –DQ _{D8}	I/O	Data Input and Output pins (x32, x36 Version)
51, 80, 1, 30	DQ _{A9} , DQ _{B9} , DQ _{C9} , DQ _{D9}	I/O	Data Input and Output pins (x36 Version)
51, 80, 1, 30	NC	—	No Connect (x32 Version)
58, 59, 62, 63, 68, 69, 72, 73, 74 8, 9, 12, 13, 18, 19, 22, 23, 24	DQ _{A1} –DQ _{A9} DQ _{B1} –DQ _{B9}	I/O	Data Input and Output pins (x18 Version)
51, 52, 53, 56, 57 75, 78, 79 1, 2, 3, 6, 7 25, 28, 29, 30	NC	—	No Connect (x18 Version)
87	\overline{BW}	I	Byte Write—Writes all enabled bytes; active low
93, 94	$\overline{B_A}$, $\overline{B_B}$	I	Byte Write Enable for DQ _A , DQ _B Data I/Os; active low
95, 96	$\overline{B_C}$, $\overline{B_D}$	I	Byte Write Enable for DQ _C , DQ _D Data I/Os; active low (x32, x36 Version)
95, 96	NC	—	No Connect (x18 Version)
89	CK	I	Clock Input Signal; active high
88	\overline{GW}	I	Global Write Enable—Writes all bytes; active low
98, 92	$\overline{E_1}$, $\overline{E_3}$	I	Chip Enable; active low
97	E ₂	I	Chip Enable; active high
86	\overline{G}	I	Output Enable; active low
83	\overline{ADV}	I	Burst address counter advance enable; active low
84, 85	\overline{ADSP} , \overline{ADSC}	I	Address Strobe (Processor, Cache Controller); active low
64	ZZ	I	Sleep Mode control; active high
31	\overline{LBO}	I	Linear Burst Order mode; active low
15, 41, 65, 91	V _{DD}	I	Core power supply
5, 10, 17, 21, 26, 40, 55, 60, 67, 71, 76, 90	V _{SS}	I	I/O and Core Ground
4, 11, 20, 27, 54, 61, 70, 77	V _{DDQ}	I	Output driver power supply
14, 16, 38, 39, 42, 43, 66	NC	—	No Connect

GS840F18/32/36A Block Diagram

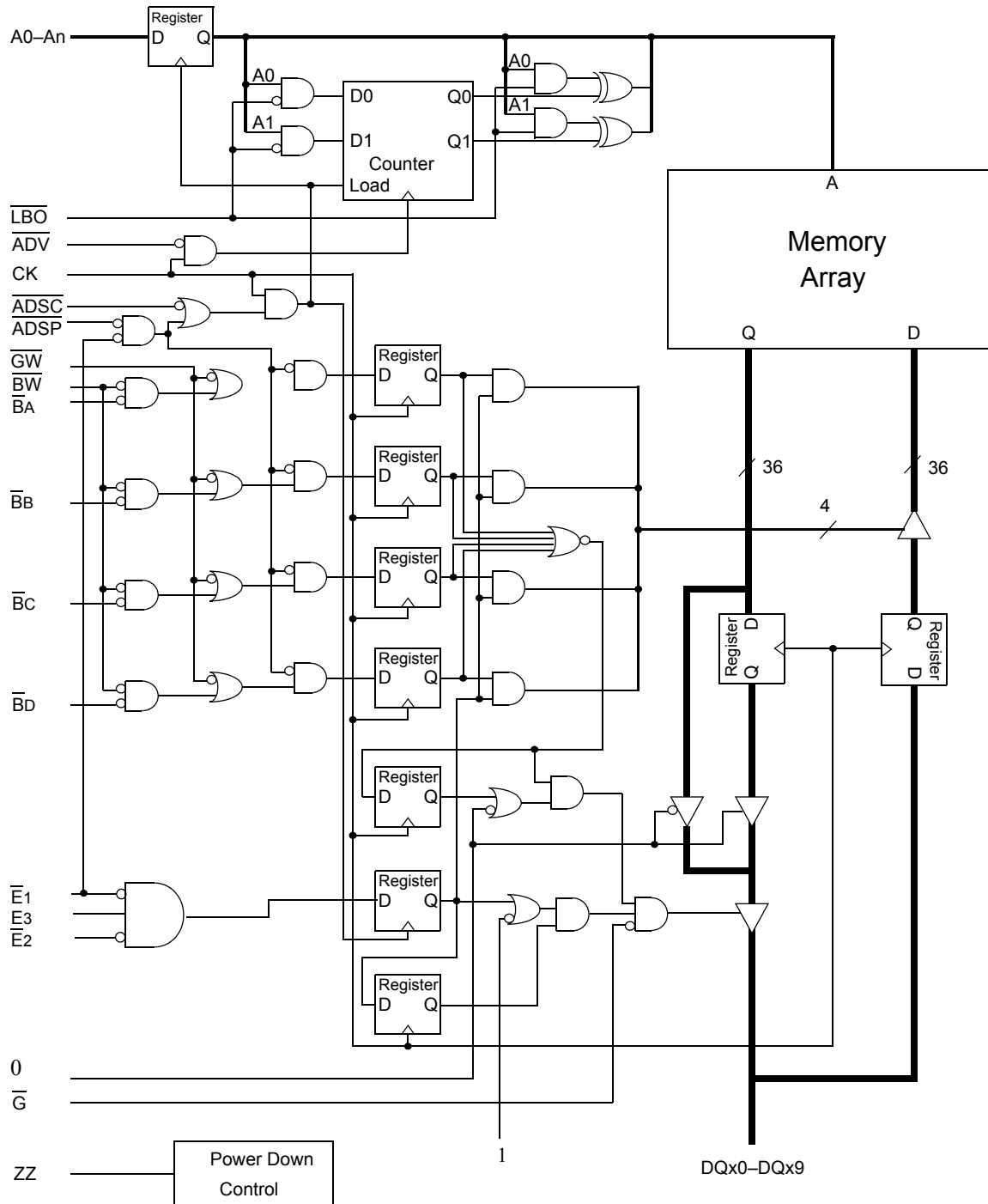

Note: Only x36 version shown for simplicity.

Mode Pin Functions

Mode Name	Pin Name	State	Function
Burst Order Control	$\overline{\text{LBO}}$	L	Linear Burst
		H or NC	Interleaved Burst
Output Register Control	$\overline{\text{FT}}$	L	Flow Through
		H or NC	Pipeline
Power Down Control	ZZ	L or NC	Active
		H	Standby, $I_{DD} = I_{SB}$

Note:

There is a are pull-up devices on the $\overline{\text{LBO}}$ and $\overline{\text{FT}}$ pins and a pull-down device on the ZZ pin, so those input pins can be unconnected and the chip will operate in the default states as specified in the above tables.

Burst Counter Sequences

Linear Burst Sequence

	A[1:0]	A[1:0]	A[1:0]	A[1:0]
1st address	00	01	10	11
2nd address	01	10	11	00
3rd address	10	11	00	01
4th address	11	00	01	10

Note: The burst counter wraps to initial state on the 5th clock.

Interleaved Burst Sequence

	A[1:0]	A[1:0]	A[1:0]	A[1:0]
1st address	00	01	10	11
2nd address	01	00	11	10
3rd address	10	11	00	01
4th address	11	10	01	00

Note: The burst counter wraps to initial state on the 5th clock.

Byte Write Truth Table

Function	$\overline{\text{GW}}$	$\overline{\text{BW}}$	$\overline{\text{B}}_A$	$\overline{\text{B}}_B$	$\overline{\text{B}}_C$	$\overline{\text{B}}_D$	Notes
Read	H	H	X	X	X	X	1
Read	H	L	H	H	H	H	1
Write byte A	H	L	L	H	H	H	2, 3
Write byte B	H	L	H	L	H	H	2, 3
Write byte c	H	L	H	H	L	H	2, 3, 4
Write byte D	H	L	H	H	H	L	2, 3, 4
Write all bytes	H	L	L	L	L	L	2, 3, 4
Write all bytes	L	X	X	X	X	X	

Notes:

- All byte outputs are active in read cycles regardless of the state of Byte Write Enable inputs.
- Byte Write Enable inputs $\overline{\text{B}}_A$, $\overline{\text{B}}_B$, $\overline{\text{B}}_C$, and/or $\overline{\text{B}}_D$ may be used in any combination with $\overline{\text{BW}}$ to write single or multiple bytes.
- All byte I/Os remain High-Z during all write operations regardless of the state of Byte Write Enable inputs.
- Bytes "c" and "d" are only available on the x32 and x36 versions.

Synchronous Truth Table

Operation	Address Used	State Diagram Key ⁵	\bar{E}_1	E^2	\overline{ADSP}	\overline{ADSC}	\overline{ADV}	W^3	DQ^4
Deselect Cycle, Power Down	None	X	H	X	X	L	X	X	High-Z
Deselect Cycle, Power Down	None	X	L	F	L	X	X	X	High-Z
Deselect Cycle, Power Down	None	X	L	F	H	L	X	X	High-Z
Read Cycle, Begin Burst	External	R	L	T	L	X	X	X	Q
Read Cycle, Begin Burst	External	R	L	T	H	L	X	F	Q
Write Cycle, Begin Burst	External	W	L	T	H	L	X	T	D
Read Cycle, Continue Burst	Next	CR	X	X	H	H	L	F	Q
Read Cycle, Continue Burst	Next	CR	H	X	X	H	L	F	Q
Write Cycle, Continue Burst	Next	CW	X	X	H	H	L	T	D
Write Cycle, Continue Burst	Next	CW	H	X	X	H	L	T	D
Read Cycle, Suspend Burst	Current		X	X	H	H	H	F	Q
Read Cycle, Suspend Burst	Current		H	X	X	H	H	F	Q
Write Cycle, Suspend Burst	Current		X	X	H	H	H	T	D
Write Cycle, Suspend Burst	Current		H	X	X	H	H	T	D

Notes:

- X = Don't Care, H = High, L = Low.
- E = T (True) if $E_2 = 1$ and $\bar{E}_3 = 0$; E = F (False) if $E_2 = 0$ or $\bar{E}_3 = 1$.
- \overline{W} = T (True) and F (False) is defined in the Byte Write Truth Table preceding.
- \bar{G} is an asynchronous input. \bar{G} can be driven high at any time to disable active output drivers. \bar{G} low can only enable active drivers (shown as "Q" in the Truth Table above).
- All input combinations shown above are tested and supported. Input combinations shown in gray boxes need not be used to accomplish basic synchronous or synchronous burst operations and may be avoided for simplicity.
- Tying \overline{ADSP} high and \overline{ADSC} low allows simple non-burst synchronous operations. See **BOLD** items above.
- Tying \overline{ADSP} high and \overline{ADV} low while using \overline{ADSC} to load new addresses allows simple burst operations. See *ITALIC* items above.

Simplified State Diagram

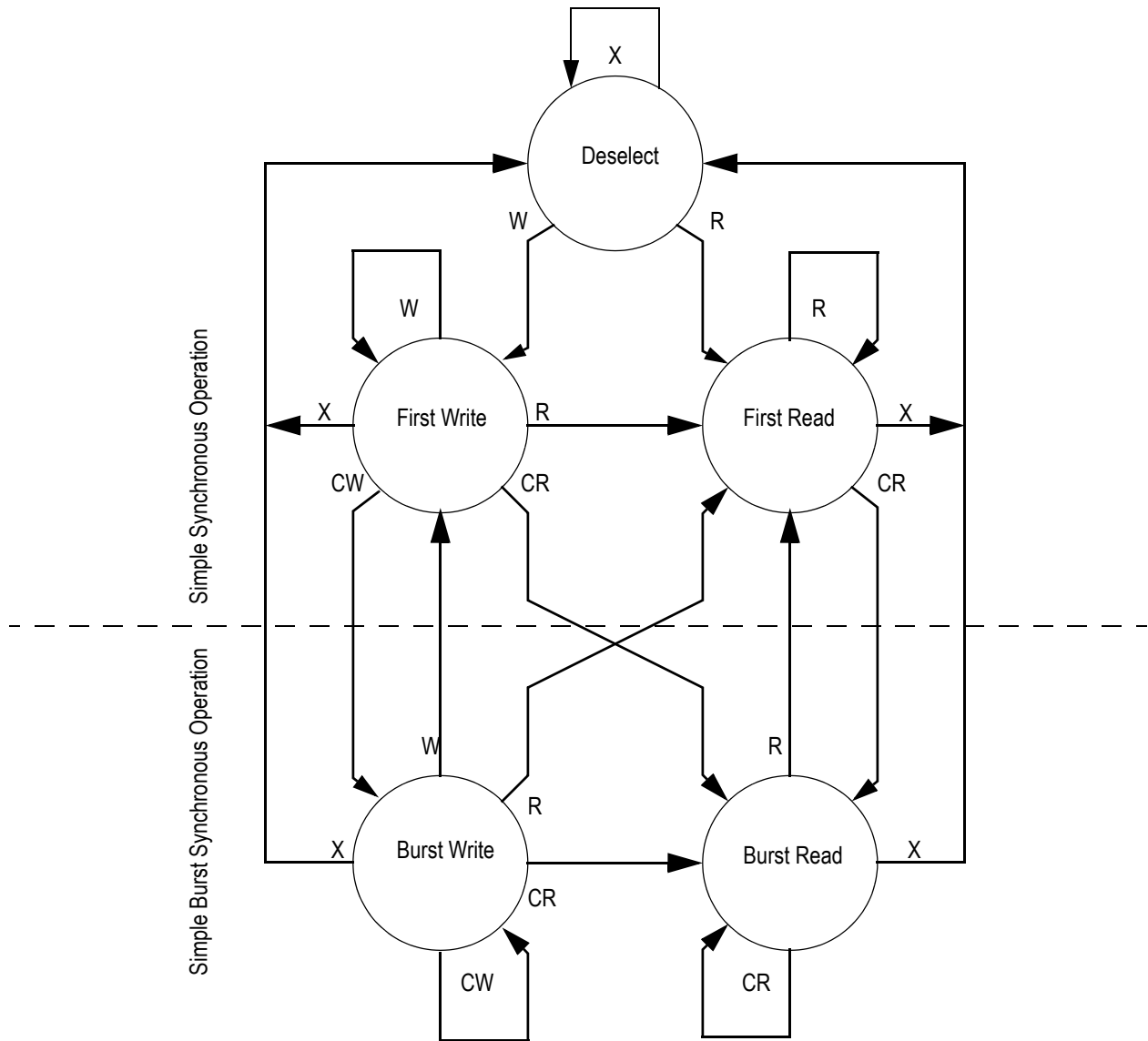

Notes:

1. The diagram shows only supported (tested) synchronous state transitions. The diagram presumes \overline{G} is tied low.
2. The upper portion of the diagram assumes active use of only the Enable ($\overline{E}_1, E_2, \overline{E}_3$) and Write ($\overline{B}_A, \overline{B}_B, \overline{B}_C, \overline{B}_D, \overline{B}_W$, and \overline{G}_W) control inputs, and that \overline{ADSP} is tied high and \overline{ADSC} is tied low.
3. The upper and lower portions of the diagram together assume active use of only the Enable, Write, and \overline{ADSC} control inputs, and assumes \overline{ADSP} is tied high and \overline{ADV} is tied low.

Simplified State Diagram with \overline{G}

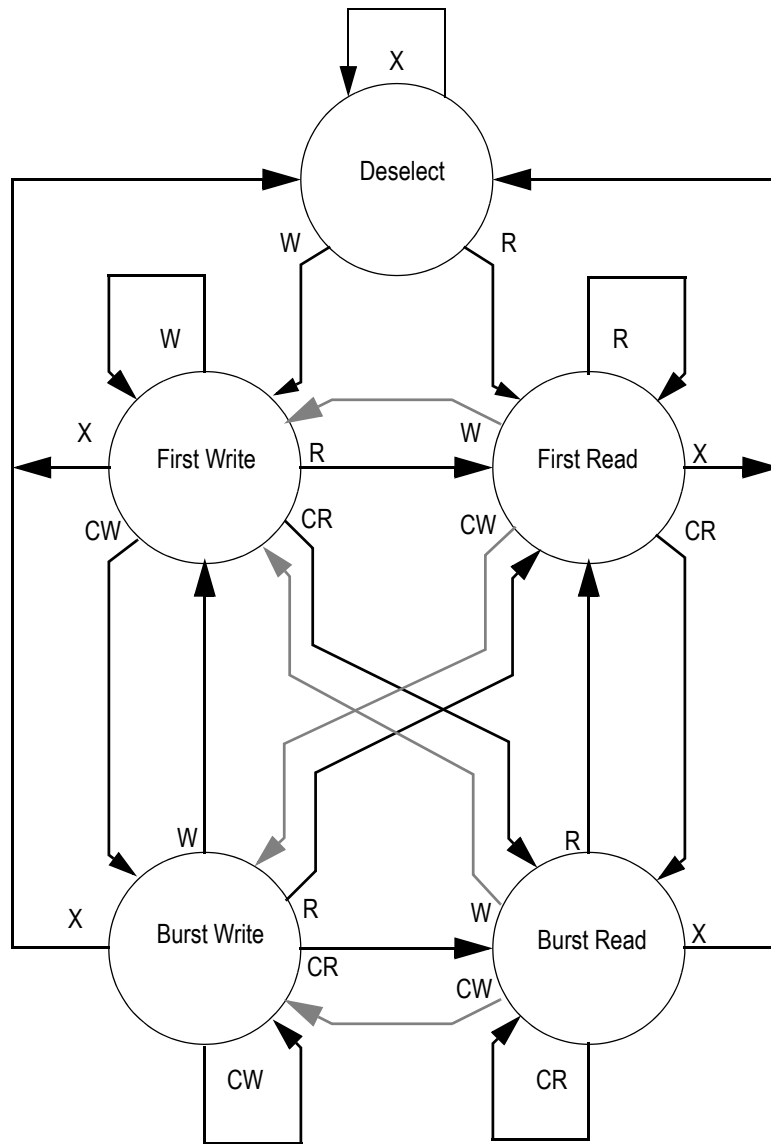

Notes:

1. The diagram shows supported (tested) synchronous state transitions plus supported transitions that depend upon the use of \overline{G} .
2. Use of "Dummy Reads" (Read Cycles with \overline{G} High) may be used to make the transition from Read cycles to Write cycles without passing through a Deselect cycle. Dummy Read cycles increment the address counter just like normal Read cycles.
3. Transitions shown in grey tone assume \overline{G} has been pulsed high long enough to turn the RAM's drivers off and for incoming data to meet Data Input Set Up Time.

Absolute Maximum Ratings

(All voltages reference to V_{SS})

Symbol	Description	Value	Unit
V_{DD}	Voltage on V_{DD} Pins	-0.5 to 4.6	V
V_{DDQ}	Voltage in V_{DDQ} Pins	-0.5 to V_{DD}	V
V_{CK}	Voltage on Clock Input Pin	-0.5 to 6	V
V_{IO}	Voltage on I/O Pins	-0.5 to $V_{DDQ}+0.5$ (≤ 4.6 V max.)	V
V_{IN}	Voltage on Other Input Pins	-0.5 to $V_{DD}+0.5$ (≤ 4.6 V max.)	V
I_{IN}	Input Current on Any Pin	+/-20	mA
I_{OUT}	Output Current on Any I/O Pin	+/-20	mA
P_D	Package Power Dissipation	1.5	W
T_{STG}	Storage Temperature	-55 to 125	$^{\circ}C$
T_{BIAS}	Temperature Under Bias	-55 to 125	$^{\circ}C$

Note:

Permanent damage to the device may occur if the Absolute Maximum Ratings are exceeded. Operation should be restricted to Recommended Operating Conditions. Exposure to conditions exceeding the Absolute Maximum Ratings, for an extended period of time, may affect reliability of this component.

Recommended Operating Conditions

Parameter	Symbol	Min.	Typ.	Max.	Unit	Notes
Supply Voltage	V_{DD}	3.135	3.3	3.6	V	
I/O Supply Voltage	V_{DDQ}	2.375	2.5	V_{DD}	V	1
Input High Voltage	V_{IH}	1.7	—	$V_{DD}+0.3$	V	2
Input Low Voltage	V_{IL}	-0.3	—	0.8	V	2
Ambient Temperature (Commercial Range Versions)	T_A	0	25	70	$^{\circ}C$	3
Ambient Temperature (Industrial Range Versions)	T_A	-40	25	85	$^{\circ}C$	3

Notes:

- Unless otherwise noted, all performance specifications quoted are evaluated for worst case at both $2.75\text{ V} \leq V_{DDQ} \leq 2.375\text{ V}$ (i.e., 2.5 V I/O) and $3.6\text{ V} \leq V_{DDQ} \leq 3.135\text{ V}$ (i.e., 3.3 V I/O) and quoted at whichever condition is worst case.
- This device features input buffers compatible with both 3.3 V and 2.5 V I/O drivers.
- Most speed grades and configurations of this device are offered in both Commercial and Industrial Temperature ranges. The part number of Industrial Temperature Range versions end the character "I". Unless otherwise noted, all performance specifications quoted are evaluated for worst case in the temperature range marked on the device.
- Input Under/overshoot voltage must be $-2\text{ V} > V_i < V_{DD}+2\text{ V}$ with a pulse width not to exceed 20% tKC.

Undershoot Measurement and Timing

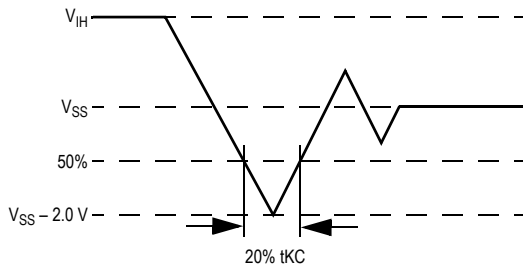

Overshoot Measurement and Timing

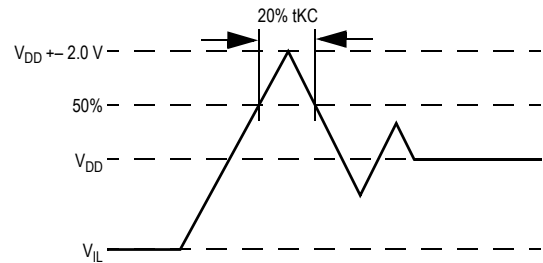

Capacitance

($T_A = 25^\circ\text{C}$, $f = 1\text{ MHz}$, $V_{DD} = 3.3\text{ V}$)

Parameter	Symbol	Test conditions	Typ.	Max.	Unit
Control Input Capacitance	C_I	$V_{DD} = 3.3\text{ V}$	3	4	pF
Input Capacitance	C_{IN}	$V_{IN} = 0\text{ V}$	4	5	pF
Output Capacitance	C_{OUT}	$V_{OUT} = 0\text{ V}$	6	7	pF

Note: This parameter is sample tested.

Package Thermal Characteristics

Rating	Layer Board	Symbol	TQFP Max	Unit	Notes
Junction to Ambient (at 200 lfm)	single	$R_{\theta JA}$	40	$^\circ\text{C/W}$	1,2,4
Junction to Ambient (at 200 lfm)	four	$R_{\theta JA}$	24	$^\circ\text{C/W}$	1,2,4
Junction to Case (TOP)		$R_{\theta JC}$	9	$^\circ\text{C/W}$	3,4

Notes:

- Junction temperature is a function of SRAM power dissipation, package thermal resistance, mounting board temperature, ambient. Temperature air flow, board density, and PCB thermal resistance.
- SCMI G-38-87.
- Average thermal resistance between die and top surface, MIL SPEC-883, Method 1012.1.
- For x18 configuration, consult factory.

AC Test Conditions

Parameter	Conditions
Input high level	2.3 V
Input low level	0.2 V
Input slew rate	1 V/ns
Input reference level	1.25 V
Output reference level	1.25 V
Output load	Fig. 1 & 2

Notes:

1. Include scope and jig capacitance.
2. Test conditions as specified with output loading as shown in Fig. 1 unless otherwise noted.
3. Output Load 2 for t_{LZ} , t_{HZ} , t_{OLZ} , and t_{OHZ} .
4. Device is deselected as defined by the Truth Table.

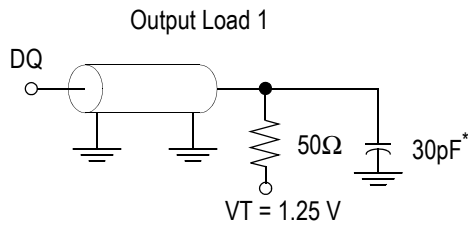

* Distributed Test Jig Capacitance

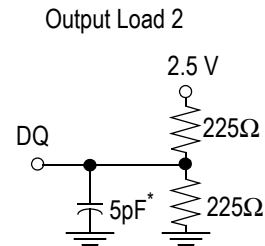

DC Electrical Characteristics

Parameter	Symbol	Test Conditions	Min	Max
Input Leakage Current (except mode pins)	I_{IL}	$V_{IN} = 0 \text{ to } V_{DD}$	-1 μA	1 μA
ZZ Input Current	I_{INZZ}	$V_{DD} \geq V_{IN} \geq V_{IH}$ $0V \leq V_{IN} \leq V_{IH}$	-1 μA -1 μA	1 μA 300 μA
Mode Pin Input Current	I_{INM}	$V_{DD} \geq V_{IN} \geq V_{IL}$ $0V \leq V_{IN} \leq V_{IL}$	-300 μA -1 μA	1 μA 1 μA
Output Leakage Current	I_{OL}	Output Disable, $V_{OUT} = 0 \text{ to } V_{DD}$	-1 μA	1 μA
Output High Voltage	V_{OH}	$I_{OH} = -4 \text{ mA}$, $V_{DDQ} = 2.375 \text{ V}$	1.7 V	—
Output High Voltage	V_{OH}	$I_{OH} = -4 \text{ mA}$, $V_{DDQ} = 3.135 \text{ V}$	2.4 V	—
Output Low Voltage	V_{OL}	$I_{OL} = 4 \text{ mA}$	—	0.4 V

Operating Currents

Parameter	Test Conditions	Symbol	-8		-8.5		-10		-12		Unit
			0 to 70°C	-40 to 85°C	0 to 70°C	-40 to 85°C	0 to 70°C	-40 to 85°C	0 to 70°C	-40 to 85°C	
Operating Current	Device Selected; All other inputs $\geq V_{IH}$ or $\leq V_{IL}$ Output open	I_{DD} Flow Through	115	125	105	115	105	115	80	90	mA
Standby Current	$ZZ \geq V_{DD} - 0.2 V$	I_{SB} Flow Through	20	30	20	30	20	30	20	30	mA
Deselect Current	Device Deselected; All other inputs $\geq V_{IH}$ or $\leq V_{IL}$	I_{DD} Flow Through	20	30	20	30	20	30	15	25	mA

AC Electrical Characteristics

	Parameter	Symbol	-8		-8.5		-10		-12		Unit
			Min	Max	Min	Max	Min	Max	Min	Max	
Flow Through	Clock Cycle Time	t _{KC}	9.1	—	10.0	—	10.0	—	15.0	—	ns
	Clock to Output Valid	t _{KQ}	—	8.0	—	8.5	—	10	—	12	ns
	Clock to Output Invalid	t _{KQX}	3.0	—	3.0	—	3.0	—	3.0	—	ns
	Clock to Output in Low-Z	t _{LZ} ¹	3.0	—	3.0	—	3.0	—	3.0	—	ns
	Clock HIGH Time	t _{KH}	1.3	—	1.3	—	1.3	—	1.3	—	ns
	Clock LOW Time	t _{KL}	1.5	—	1.5	—	1.5	—	1.5	—	ns
	Clock to Output in High-Z	t _{HZ} ¹	1.5	3.2	1.5	3.5	1.5	3.8	1.5	5	ns
	\bar{G} to Output Valid	t _{OE}	—	3.2	—	3.5	—	3.8	—	5	ns
	\bar{G} to output in Low-Z	t _{OLZ} ¹	0	—	0	—	0	—	0	—	ns
	\bar{G} to output in High-Z	t _{OHZ} ¹	—	3.2	—	3.5	—	3.8	—	5	ns
	Setup time	t _S	1.5	—	1.5	—	1.5	—	1.5	—	ns
	Hold time	t _H	0.5	—	0.5	—	0.5	—	0.5	—	ns
	ZZ setup time	t _{ZZS} ²	5	—	5	—	5	—	5	—	ns
	ZZ hold time	t _{ZZH} ²	1	—	1	—	1	—	1	—	ns
	ZZ recovery	t _{ZZR}	20	—	20	—	20	—	20	—	ns

Notes:

- These parameters are sampled and are not 100% tested
- ZZ is an asynchronous signal. However, In order to be recognized on any given clock cycle, ZZ must meet the specified setup and hold times as specified above.

Write Cycle Timing

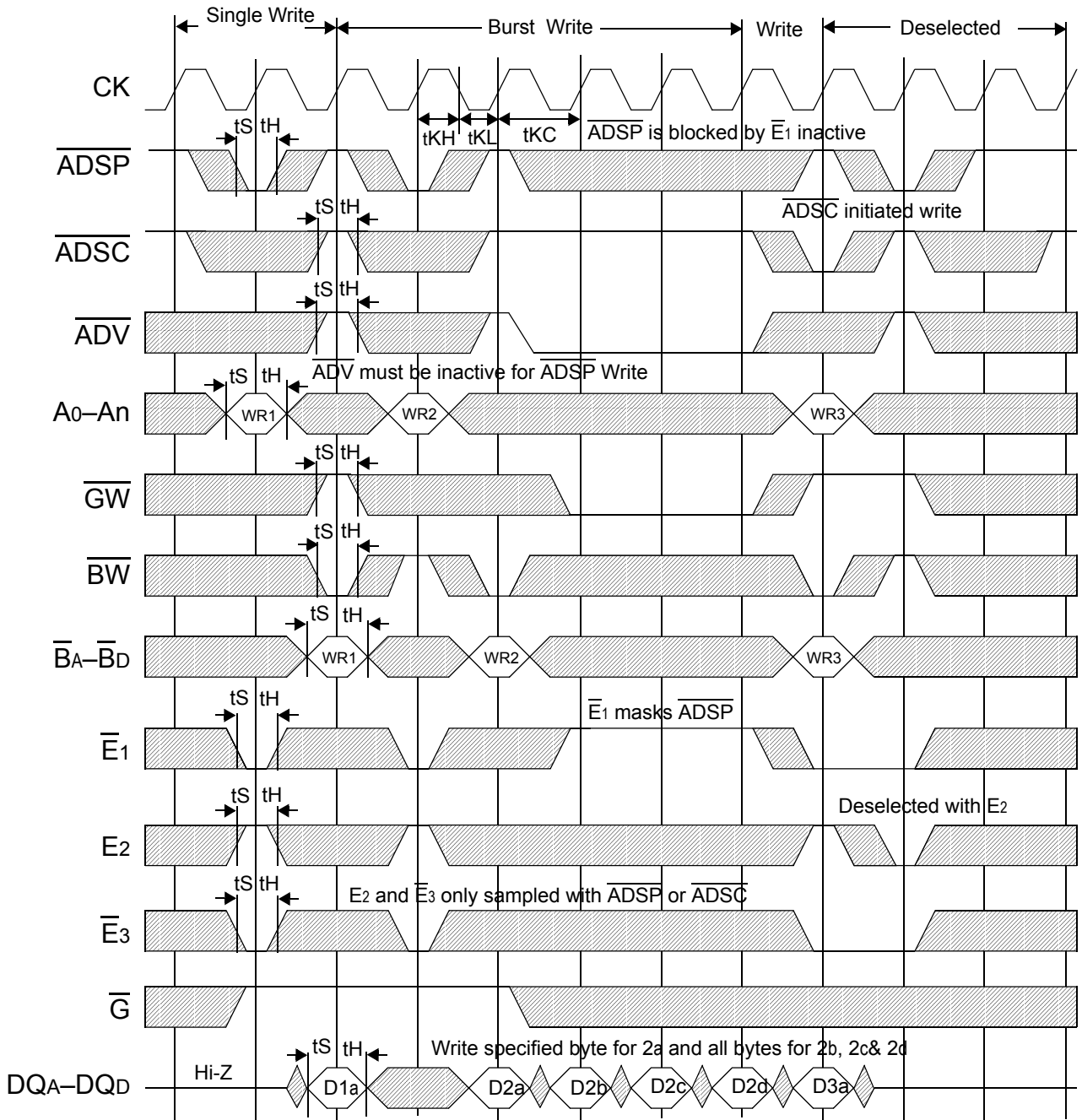

Flow Through Read Cycle Timing

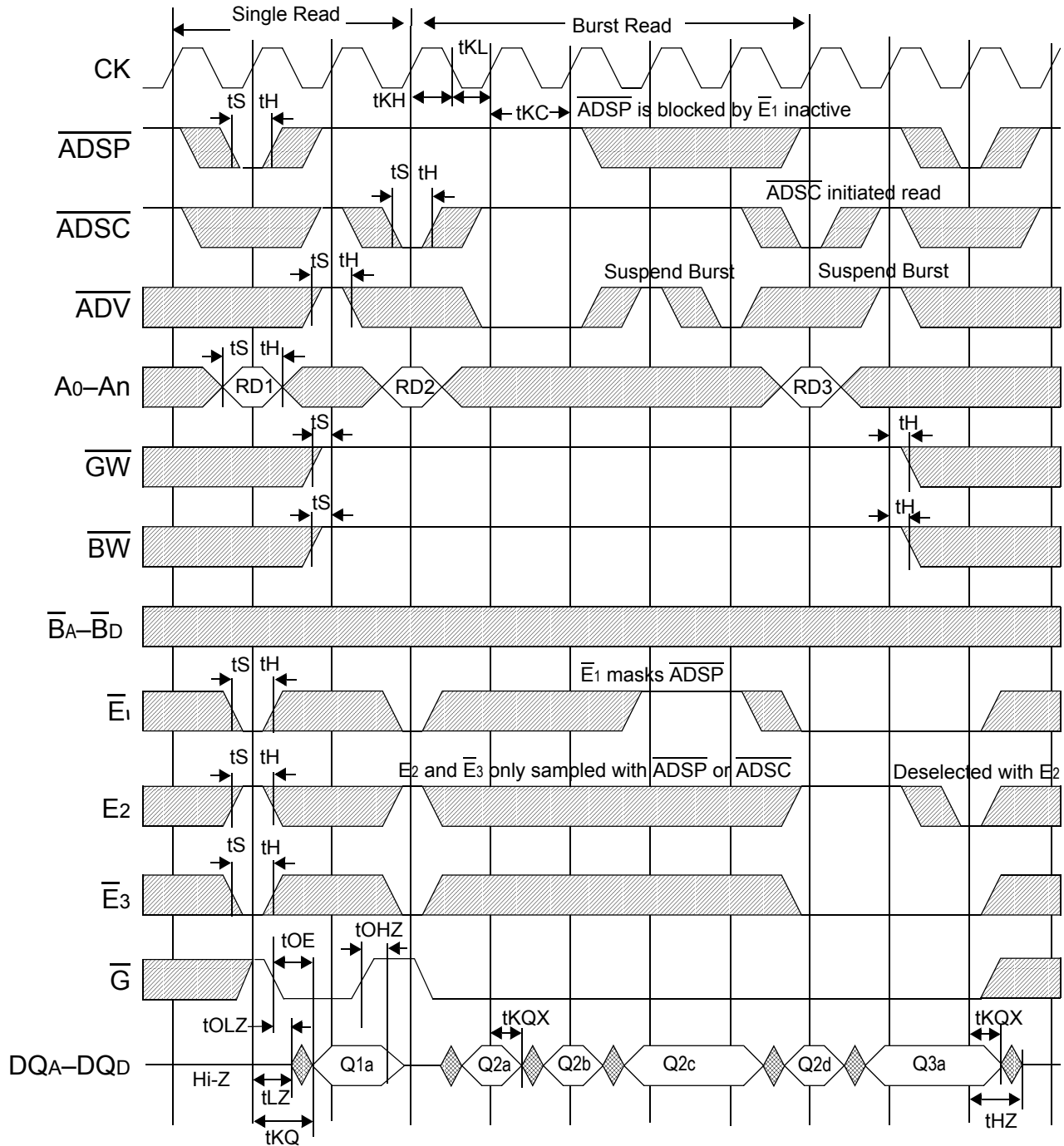

Flow Through Read-Write Cycle Timing

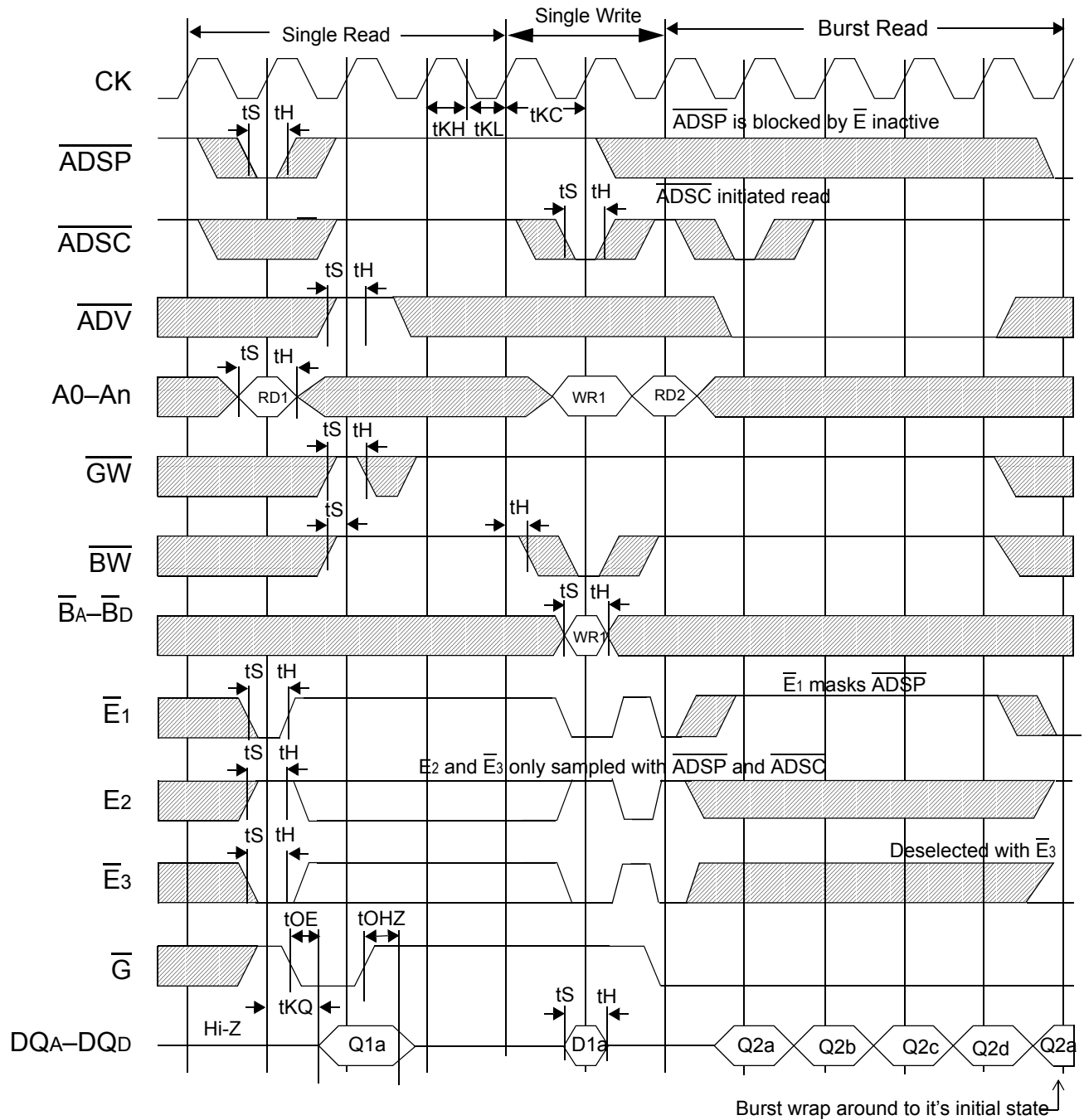

Sleep Mode Timing Diagram

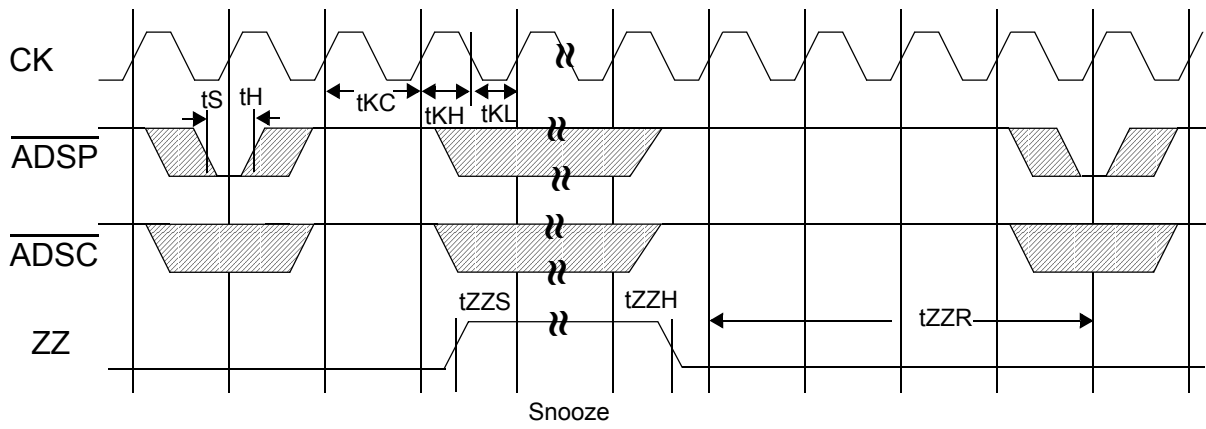

GS840F18/32/36A Output Driver Characteristics

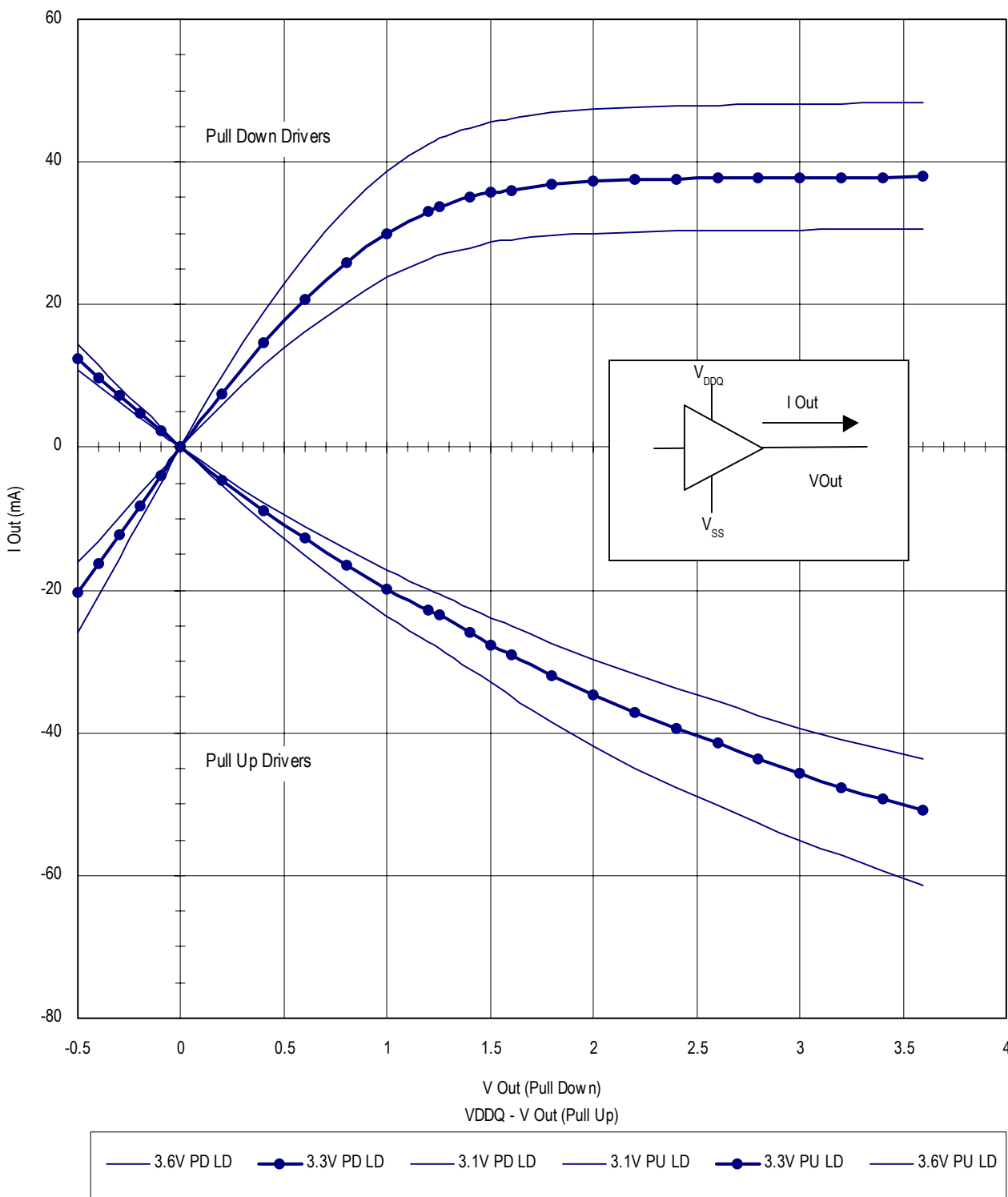

TQFP Package Drawing

Symbol	Description	Min.	Nom.	Max
A1	Standoff	0.05	0.10	0.15
A2	Body Thickness	1.35	1.40	1.45
b	Lead Width	0.20	0.30	0.40
c	Lead Thickness	0.09	—	0.20
D	Terminal Dimension	21.9	22.0	22.1
D1	Package Body	19.9	20.0	20.1
E	Terminal Dimension	15.9	16.0	16.1
E1	Package Body	13.9	14.0	14.1
e	Lead Pitch	—	0.65	—
L	Foot Length	0.45	0.60	0.75
L1	Lead Length	—	1.00	—
Y	Coplanarity	—	—	0.10
θ	Lead Angle	0°	—	7°

Notes:

1. All dimensions are in millimeters (mm).
2. Package width and length do not include mold protrusion.

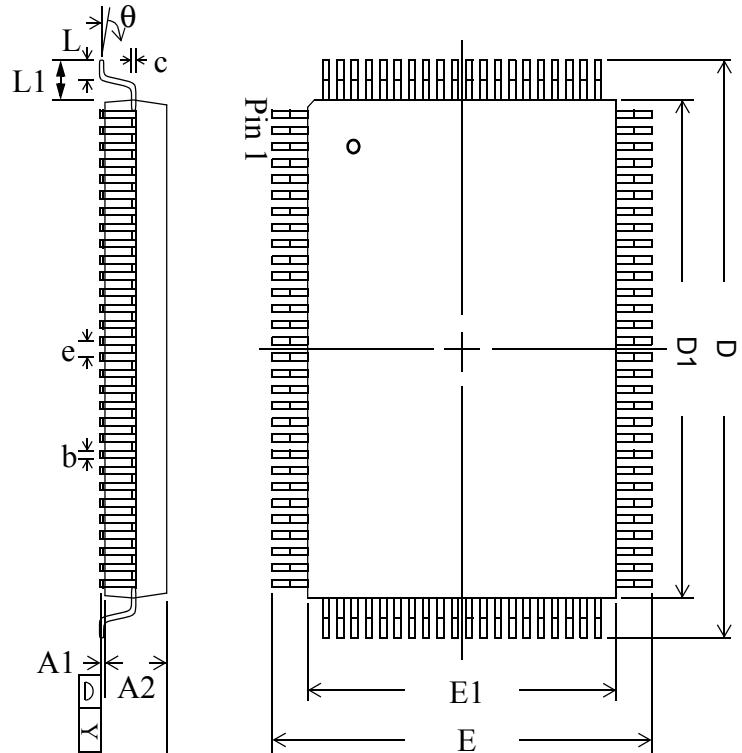

Ordering Information for GSI Synchronous Burst RAMS

Org	Part Number ¹	Type	Package	Speed ² (Mhz/ns)	T _A ³	Status
256K x 18	GS840F18AT-8	Flow Through	TQFP	8	C	
256K x 18	GS840F18AT-8.5	Flow Through	TQFP	8.5	C	
256K x 18	GS840F18AT-10	Flow Through	TQFP	10	C	
256K x 18	GS840F18AT-12	Flow Through	TQFP	12	C	
128K x 32	GS840F32AT-8	Flow Through	TQFP	8	C	
128K x 32	GS840F32AT-8.5	Flow Through	TQFP	8.5	C	
128K x 32	GS840F32AT-10	Flow Through	TQFP	10	C	
128K x 32	GS840F32AT-12	Flow Through	TQFP	12	C	
128K x 36	GS840F36AT-8	Flow Through	TQFP	8	C	
128K x 36	GS840F36AT-8.5	Flow Through	TQFP	8.5	C	
128K x 36	GS840F36AT-10	Flow Through	TQFP	8.5	C	
128K x 36	GS840F36AT-12	Flow Through	TQFP	8.5	C	
256K x 18	GS840F18AT-8I	Flow Through	TQFP	8	I	
256K x 18	GS840F18AT-8.5I	Flow Through	TQFP	8.5	I	
256K x 18	GS840F18AT-10I	Flow Through	TQFP	10	I	
256K x 18	GS840F18AT-12I	Flow Through	TQFP	12	I	
128K x 32	GS840F32AT-8I	Flow Through	TQFP	8	I	
128K x 32	GS840F32AT-8.5I	Flow Through	TQFP	8.5	I	
128K x 32	GS840F32AT-10I	Flow Through	TQFP	10	I	
128K x 32	GS840F32AT-12I	Flow Through	TQFP	12	I	
128K x 36	GS840F36AT-8I	Flow Through	TQFP	8	I	
128K x 36	GS840F36AT-8.5I	Flow Through	TQFP	8.5	I	
128K x 36	GS840F36AT-10I	Flow Through	TQFP	10	I	
128K x 36	GS840F36AT-12I	Flow Through	TQFP	12	I	

Notes:

- Customers requiring delivery in Tape and Reel should add the character "T" to the end of the part number. Example: GS840F32AT-8T.
- The speed column indicates the cycle frequency (MHz) of the device in Pipelined mode and the latency (ns) in Flow Through mode. Each device is Pipeline/Flow Through mode-selectable by the user.
- T_A = C = Commercial Temperature Range. T_A = I = Industrial Temperature Range.
- GSI offers other versions this type of device in many different configurations and with a variety of different features, only some of which are covered in this data sheet. See the GSI Technology web site (www.gsistechnology.com) for a complete listing of current offerings.

Revision History

Rev. Code: Old; New	Types of Changes Format or Content	Page /Revisions;Reason
GS84018/32/362/2000G; 840F18A_r1_02	Content	<ul style="list-style-type: none"> • Updated pin description table
840F18A_r1_02; 840F18A_r1_03	Content/Format	<ul style="list-style-type: none"> • Added “non-A” speed bins to Operating Currents table, AC Electrical Characteristics table, and Ordering Information table • Updated format to fit Technical Documentation standards
840F18A_r1_03; 840F18A_r1_04	Content/Format	<ul style="list-style-type: none"> • Updated table on page 1 • Updated Operating Currents table on page 14 • Updated AC Electrical Characteristics table on page 14 • Updated format to comply with present Technical Documentation standards
840F18A_r1_04; 840F18A_r1_05	Content	<ul style="list-style-type: none"> • Reduced I_{DD} by 20 mA in table on page 1 and Operating Currents table
840F18A_r1_05; 840F18A_r1_06	Content	<ul style="list-style-type: none"> • Removed 7.5 ns references from entire datasheet