

TQFP, BGA
Commercial Temp
Industrial Temp

256K x 18, 128K x 32, 128K x 36 180Mhz - 100Mhz
4Mb Sync Burst SRAMs 3.3V VDD
3.3V & 2.5V I/O

Features

- \overline{FT} pin for user configurable flow through or pipelined operation.
- Single Cycle Deselect (SCD) Operation.
- High Output Drive current.
- 3.3V +10%/-5% Core power supply
- 2.5V or 3.3V I/O supply.
- LBO pin for linear or interleaved burst mode.
- Internal input resistors on mode pins allow floating mode pins.
- Default to Interleaved Pipelined Mode.
- Byte write (BW) and/or global write (GW) operation.
- Common data inputs and data outputs.
- Clock Control, registered, address, data, and control.
- Internal Self-Timed Write cycle.
- Automatic power-down for portable applications.
- JEDEC standard 100-lead TQFP or 119 Bump BGA package.

		-180	-166	-150	-100
Pipeline 3-1-1-1	tCycle	5.5ns	6.0ns	6.6ns	10ns
	tkQ	3.2ns	3.5ns	3.8ns	4.5ns
	IDD	330mA	310mA	275mA	190mA
Flow Through 2-1-1-1	tkQ	8ns	8.5ns	10ns	12ns
	tCycle	10ns	10ns	10ns	15ns
	IDD	190mA	190mA	190mA	140mA

Functional Description

Applications

The GS840H18/32/36 is a 4,718,592 bit (4,194,304 bit for x32 version) high performance synchronous SRAM with a 2 bit burst address counter. Although of a type originally developed for Level 2 Cache applications supporting high performance CPU s, the device now finds application in synchronous SRAM applications ranging from DSP main store to networking chip set support. The GS840H18/32/36 is available in a JEDEC standard 100-lead TQFP or 119 Bump BGA package.

Controls

Addresses, data I/O s, chip enables (\overline{E}_1 , E_2 , \overline{E}_3), address burst control inputs (ADSP, ADSC, ADV) and write control inputs (Bx, BW, GW) are synchronous and are controlled by a positive edge triggered clock input (CK). Output enable (\overline{G}) and power down control (ZZ) are asynchronous inputs. Burst cycles can be initiated with either ADSP or ADSC inputs. In Burst mode, subsequent burst addresses are generated internally and are controlled by ADV. The burst address counter may be configured to count in either linear or interleave order

with the Linear Burst Order (\overline{LBO}) input. The Burst function need not be used. New addresses can be loaded on every cycle with no degradation of chip performance.

Flow Through / Pipeline Reads

The function of the Data Output register can be controlled by the user via the \overline{FT} mode pin/bump (pin 14 in the TQFP and bump 5R in the BGA,). Holding the \overline{FT} mode pin/bump low places the RAM in Flow through mode, causing output data to bypass the Data Output Register. Holding \overline{FT} high places the RAM in Pipelined Mode, activating the rising edge triggered Data Output Register.

SCD Pipelined Reads

The GS840H18/32/36 is an SCD (Single Cycle Deselect) pipelined synchronous SRAM. DCD (Dual Cycle Deselect) versions are also available. SCD SRAMs pipeline deselect commands one stage less than read commands. SCD RAMs begin turning off their outputs immediately after the deselect command has been captured in the input registers.

Byte Write and Global Write

Byte write operation is performed by using byte write enable (\overline{BW}) input combined with one or more individual byte write signals (Bx). In addition, Global Write (\overline{GW}) is available for writing all bytes at one time, regardless of the Byte Write control inputs.

Sleep Mode

Low power (Sleep mode) is attained through the assertion (High) of the ZZ signal, or by stopping the clock (CK). Memory data is retained during Sleep mode.

Core and Interface Voltages

The GS840H18/32/36 operates on a 3.3V power supply and all inputs/outputs are 3.3V and 2.5V compatible. Separate output power (V_{DDQ}) pins are used to de-couple output noise from the internal circuit.

GS840H18 100 Pin TQFP Pinout

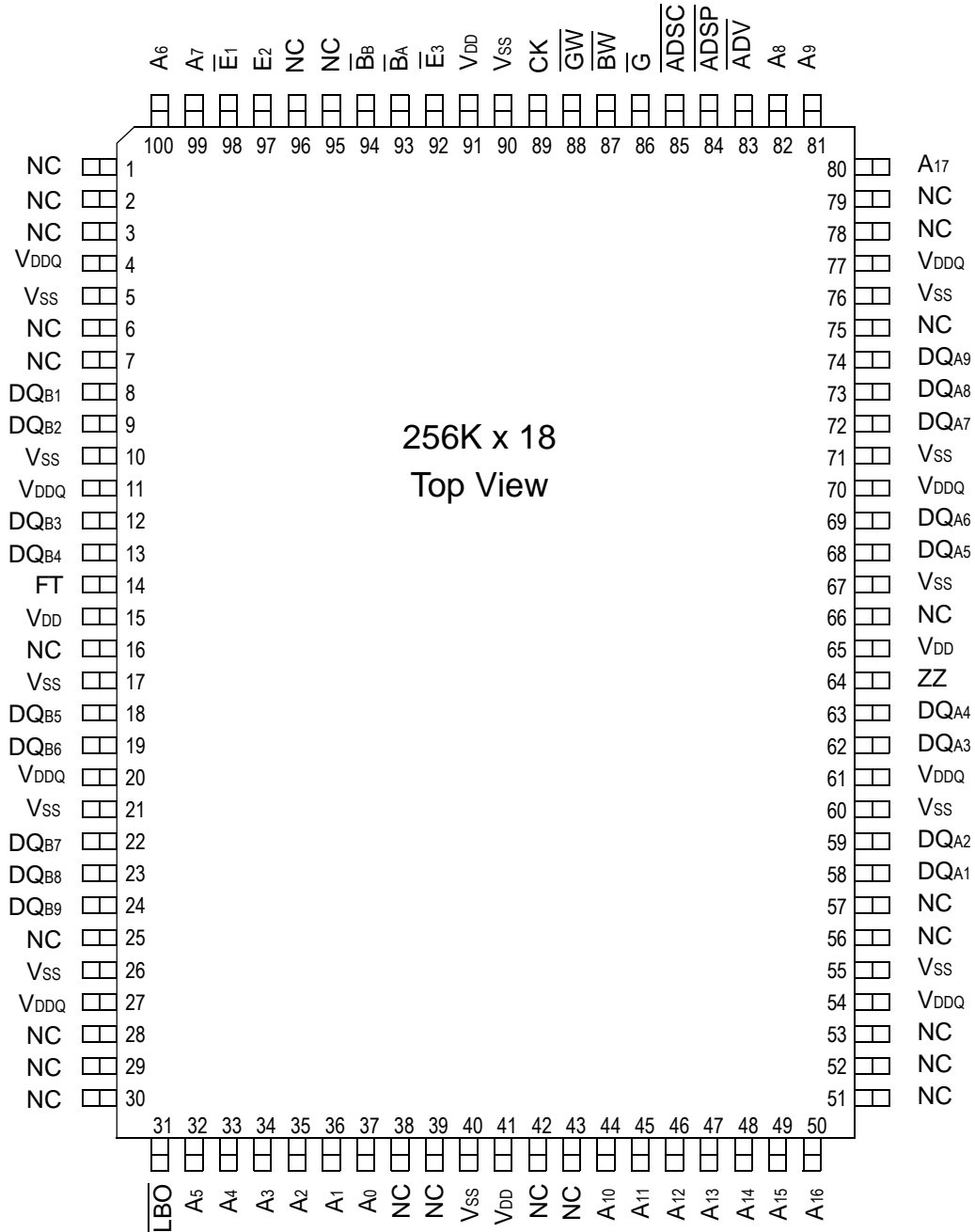

GS840H36 100 Pin TQFP Pinout

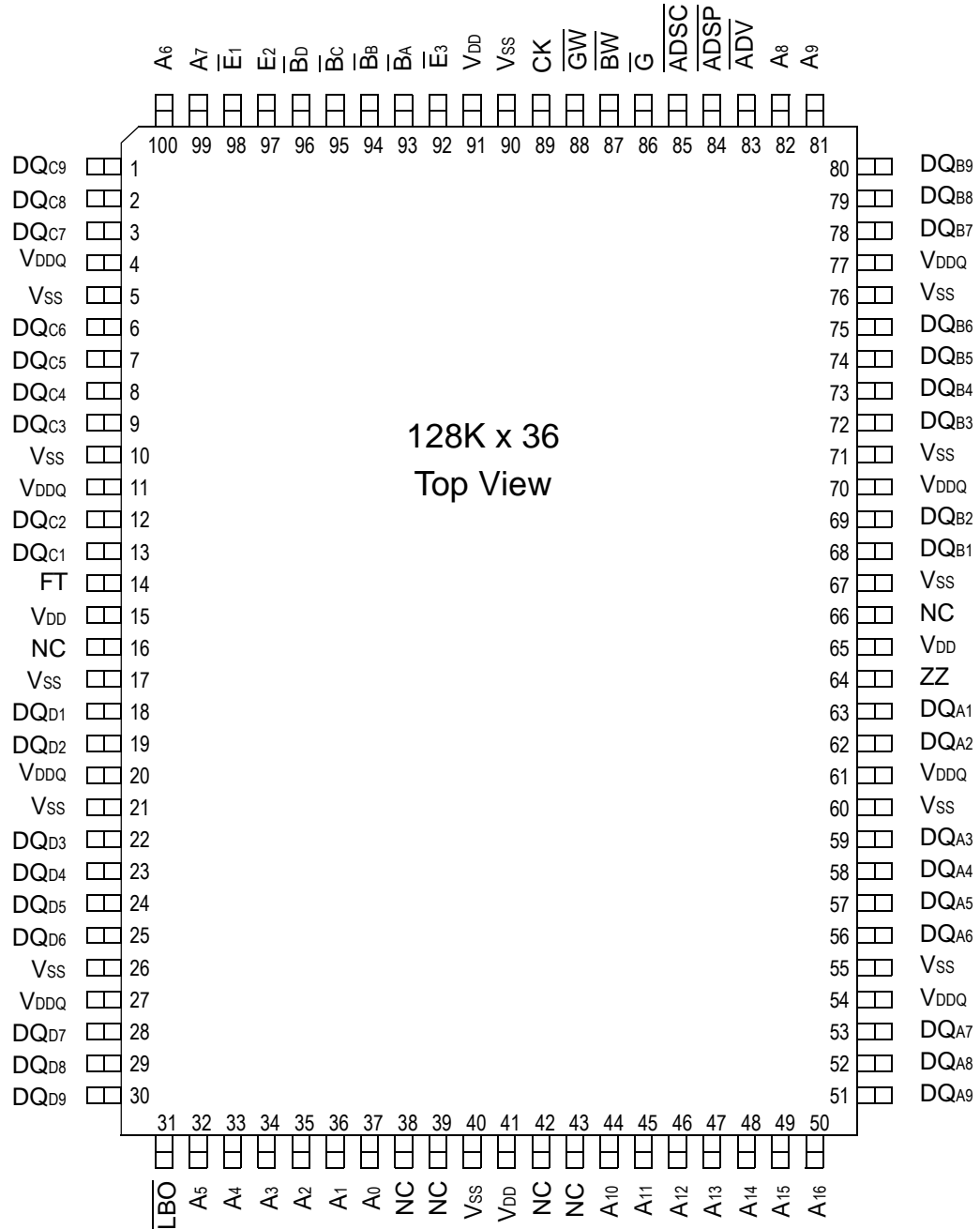

TQFP Pin Description

Pin Location	Symbol	Type	Description
37, 36	A ₀ , A ₁	I	Address field LSB s and Address Counter preset Inputs
35, 34, 33, 32, 100, 99, 82, 81, 44, 45, 46, 47, 48, 49, 50	A ₂₋₁₆	I	Address Inputs
80	A ₁₇	I	Address Inputs (x18 versions)
52, 53, 56, 57, 58, 59, 62, 63 68, 69, 72, 73, 74, 75, 78, 79 2, 3, 6, 7, 8, 9, 12, 13 18, 19, 22, 23, 24, 25, 28, 29	DQ _{A1-DQ_{A8}} DQ _{B1-DQ_{B8}} DQ _{C1-DQ_{C8}} DQ _{D1-DQ_{D8}}	I/O	Data Input and Output pins. (x32, x36 Version)
51, 80, 1, 30	DQ _{A9} , DQ _{B9} , DQ _{C9} , DQ _{D9}	I/O	Data Input and Output pins. (x36 Version)
51, 80, 1, 30	NC		No Connect (x32 Version)
58, 59, 62, 63, 68, 69, 72, 73, 74 8, 9, 12, 13, 18, 19, 22, 23, 24	DQ _{A1-DQ_{A9}} DQ _{B1-DQ_{B9}}	I/O	Data Input and Output pins. (x18 Version)
51, 52, 53, 56, 57 75, 78, 79 1, 2, 3, 6, 7 25, 28, 29, 30	NC	-	No Connect (x18 Version)
87	\overline{BW}	I	Byte Write. Writes all enabled bytes. Active Low.
93, 94	\overline{BA} , \overline{BB}	I	Byte Write Enable for DQ _A , DQ _B Data I/O s. Active Low.
95, 96	\overline{BC} , \overline{BD}	I	Byte Write Enable for DQ _C , DQ _D Data I/O s. Active Low. (x32, x36 Version)
95, 96	NC	-	No Connect (x18 Version)
89	CK	I	Clock Input Signal. Active High.
88	\overline{GW}	I	Global Write Enable. Writes all bytes. Active Low.
98, 92	$\overline{E_1}$, $\overline{E_3}$	I	Chip Enable. Active Low.
97	E ₂	I	Chip Enable. Active High.
86	\overline{G}	I	Output Enable. Active Low.
83	\overline{ADV}	I	Burst address counter advance enable. Active Low.
84, 85	\overline{ADSP} , \overline{ADSC}	I	Address Strobe (Processor, Cache Controller). Active Low.
64	\overline{ZZ}	I	Sleep Mode control. Active High.
14	\overline{FT}	I	Flow Through or Pipeline mode. Active Low.
31	\overline{LBO}	I	Linear Burst Order mode. Active Low.
15, 41, 65, 91	V _{DD}	I	Core power supply.
5, 10, 17, 21, 26, 40, 55, 60, 67, 71, 76, 90	V _{SS}	I	I/O and Core Ground.
4, 11, 20, 27, 54, 61, 70, 77	V _{DDQ}	I	Output driver power supply.
16, 38, 39, 42, 43, 66	NC	-	No Connect.

GS840H18 Pad Out

119 Bump BGA - Top View

	1	2	3	4	5	6	7
A	VDDQ	A6	A7	\overline{ADSP}	A8	A9	VDDQ
B	NC	E2	A4	\overline{ADSC}	A15	$\overline{E3}$	NC
C	NC	A5	A3	VDD	A14	A16	NC
D	DQB1	NC	VSS	NC	VSS	DQA9	NC
E	NC	DQB2	VSS	$\overline{E1}$	VSS	NC	DQA8
F	VDDQ	NC	VSS	\overline{G}	VSS	DQA7	VDDQ
G	NC	DQB3	\overline{BB}	\overline{ADV}	NC	NC	DQA6
H	DQB4	NC	VSS	\overline{GW}	VSS	DQA5	NC
J	VDDQ	VDD	NC	VDD	NC	VDD	VDDQ
K	NC	DQB5	VSS	CK	VSS	NC	DQA4
L	DQB6	NC	NC	NC	\overline{BA}	DQA3	NC
M	VDDQ	DQB7	VSS	\overline{BW}	VSS	NC	VDDQ
N	DQB8	NC	VSS	A1	VSS	DQA2	NC
P	NC	DQB9	VSS	A0	VSS	NC	DQA1
R	NC	A2	\overline{LBO}	VDD	\overline{FT}	A13	NC
T	NC	A10	A11	NC	A12	A17	ZZ
U	VDDQ	NC	NC	NC	NC	NC	VDDQ

GS840H32 Pad Out
119 Bump BGA - Top View

	1	2	3	4	5	6	7
A	VDDQ	A6	A7	\overline{ADSP}	A8	A9	VDDQ
B	NC	E2	A4	\overline{ADSC}	A15	$\overline{E3}$	NC
C	NC	A5	A3	VDD	A14	A16	NC
D	DQC4	NC	VSS	NC	VSS	NC	DQB4
E	DQC3	DQC8	VSS	$\overline{E1}$	VSS	DQB8	DQB3
F	VDDQ	DQC7	VSS	\overline{G}	VSS	DQB7	VDDQ
G	DQC2	DQC6	\overline{Bc}	\overline{ADV}	\overline{Bb}	DQB6	DQB2
H	DQC1	DQC5	VSS	\overline{GW}	VSS	DQB5	DQB1
J	VDDQ	VDD	NC	VDD	NC	VDD	VDDQ
K	DQD1	DQD5	VSS	CK	VSS	DQA5	DQA1
L	DQD2	DQD6	\overline{Bd}	NC	\overline{Ba}	DQA6	DQA2
M	VDDQ	DQD78	VSS	\overline{BW}	VSS	DQA7	VDDQ
N	DQD3	DQD8	VSS	A1	VSS	DQA8	DQA3
P	DQD4	NC	VSS	A0	VSS	NC	DQA4
R	NC	A2	\overline{LBO}	VDD	\overline{FT}	A13	NC
T	NC	NC	A10	A11	A12	NC	ZZ
U	VDDQ	NC	NC	NC	NC	NC	VDDQ

GS840H36Pad Out
119 Bump BGA - Top View

	1	2	3	4	5	6	7
A	VDDQ	A6	A7	\overline{ADSP}	A8	A9	VDDQ
B	NC	E2	A4	\overline{ADSC}	A15	$\overline{E3}$	NC
C	NC	A5	A3	VDD	A14	A16	NC
D	DQC4	DQC9	VSS	NC	VSS	DQB9	DQB4
E	DQC3	DQC8	VSS	$\overline{E1}$	VSS	DQB8	DQB3
F	VDDQ	DQC7	VSS	\overline{G}	VSS	DQB7	VDDQ
G	DQC2	DQC6	\overline{Bc}	\overline{ADV}	\overline{Bb}	DQB6	DQB2
H	DQC1	DQC5	VSS	\overline{GW}	VSS	DQB5	DQB1
J	VDDQ	VDD	NC	VDD	NC	VDD	VDDQ
K	DQD1	DQD5	VSS	CK	VSS	DQA5	DQA1
L	DQD2	DQD6	\overline{Bd}	NC	\overline{Ba}	DQA6	DQA2
M	VDDQ	DQD78	VSS	\overline{BW}	VSS	DQA7	VDDQ
N	DQD3	DQD8	VSS	A1	VSS	DQA8	DQA3
P	DQD4	DQD9	VSS	A0	VSS	DQA9	DQA4
R	NC	A2	\overline{LBO}	VDD	\overline{FT}	A13	NC
T	NC	NC	A10	A11	A12	NC	ZZ
U	VDDQ	NC	NC	NC	NC	NC	VDDQ

BGA Pin Description

Pin Location	Symbol	Type	Description
N4, P4	A ₀ , A ₁	I	Address field LSB s and Address Counter Preset Inputs.
A2, A3, A5, A6, B3, B5, C2, C3, C5, C6, R2, R6, T3, T5	A _n	I	Address Inputs
T4	A _n		Address Input (x32/36 Versions)
T2, T6	NC	-	No Connect (x32/36 Versions)
T2, T6	A _n	I	Address Input (x18 Version)
K7, K6, L7, L6, M6, N7, N6, P7 H7, H6, G7, G6, F6, E7, E6, D7 H1, H2, G1, G2, F2, E1, E2, D1 K1, K2, L1, L2, M2, N1, N2, P1	DQA ₁ -DQA ₈ DQB ₁ -DQB ₈ DQC ₁ -DQC ₈ DQD ₁ -DQD ₈	I/O	Data Input and Output pins. (x32/36 Versions)
P6, D6, D2, P2	DQA ₉ , DQB ₉ , DQC ₉ , DQD ₉	I/O	Data Input and Output pins. (x36 Version)
P6, D6, D2, P2	NC	-	No Connect (x32 Version)
L5, G5, G3, L3	\overline{BA} , \overline{BB} , \overline{BC} , \overline{BD}	I	Byte Write Enable for DQA, DQB, DQC, DQD I/O s. Active Low. (x36 Version)
P7, N6, L6, K7, H6, G7, F6, E7, D6 D1, E2, G2, H1, K2, L1, M2, N1, P2	DQA ₁ -DQA ₉ DQB ₁ -DQB ₉	I/O	Data Input and Output pins. (x18 Version)
L5, G3	\overline{BA} , \overline{BB}	I	Byte Write Enable for DQA, DQB I/O s. Active Low. (x18 Version)
B1, C1, R1, T1, U2, J3, U3, D4, L4, U4, J5, U5, U6, B7, C7, R7	NC	-	No Connect
P6, N7, M6, L7, K6, H7, G6, E6, D7, D2, B1, E1, F2, G1, H2, K1, L2, N2, P1, G5, L3, T4	NC	-	No Connect (x18 Version)
K4	CK	I	Clock Input Signal. Active High.
M4	\overline{BW}	I	Byte Write. Writes all enabled bytes. Active Low.
H4	\overline{GW}	I	Global Write Enable. Writes all bytes. Active Low.
E4, B6	$\overline{E1}$, $\overline{E3}$	I	Chip Enable. Active Low.
B2	$\overline{E2}$	I	Chip Enable. Active High.
F4	\overline{G}	I	Output Enable. Active Low.
G4	\overline{ADV}	I	Burst address counter advance enable. Active Low.
A4, B4	\overline{ADSP} , \overline{ADSC}	I	Address Strobe (Processor, Cache Controller). Active Low.
T7	\overline{ZZ}	I	Sleep Mode control. Active High.
R5	\overline{FT}	I	Flow Through or Pipeline mode. Active Low.
R3	\overline{LBO}	I	Linear Burst Order mode. Active Low.
J2, C4, J4, R4, J6	V _{DD}	I	Core power supply.
D3, E3, F3, H3, K3, M3, N3, P3, D5, E5, F5, H5, K5, M5, N5, P5	V _{SS}	I	I/O and Core Ground.
A1, F1, J1, M1, U1, A7, F7, J7, M7, U7	V _{DDQ}	I	Output driver power supply.

GS840H18/32/36 Block Diagram

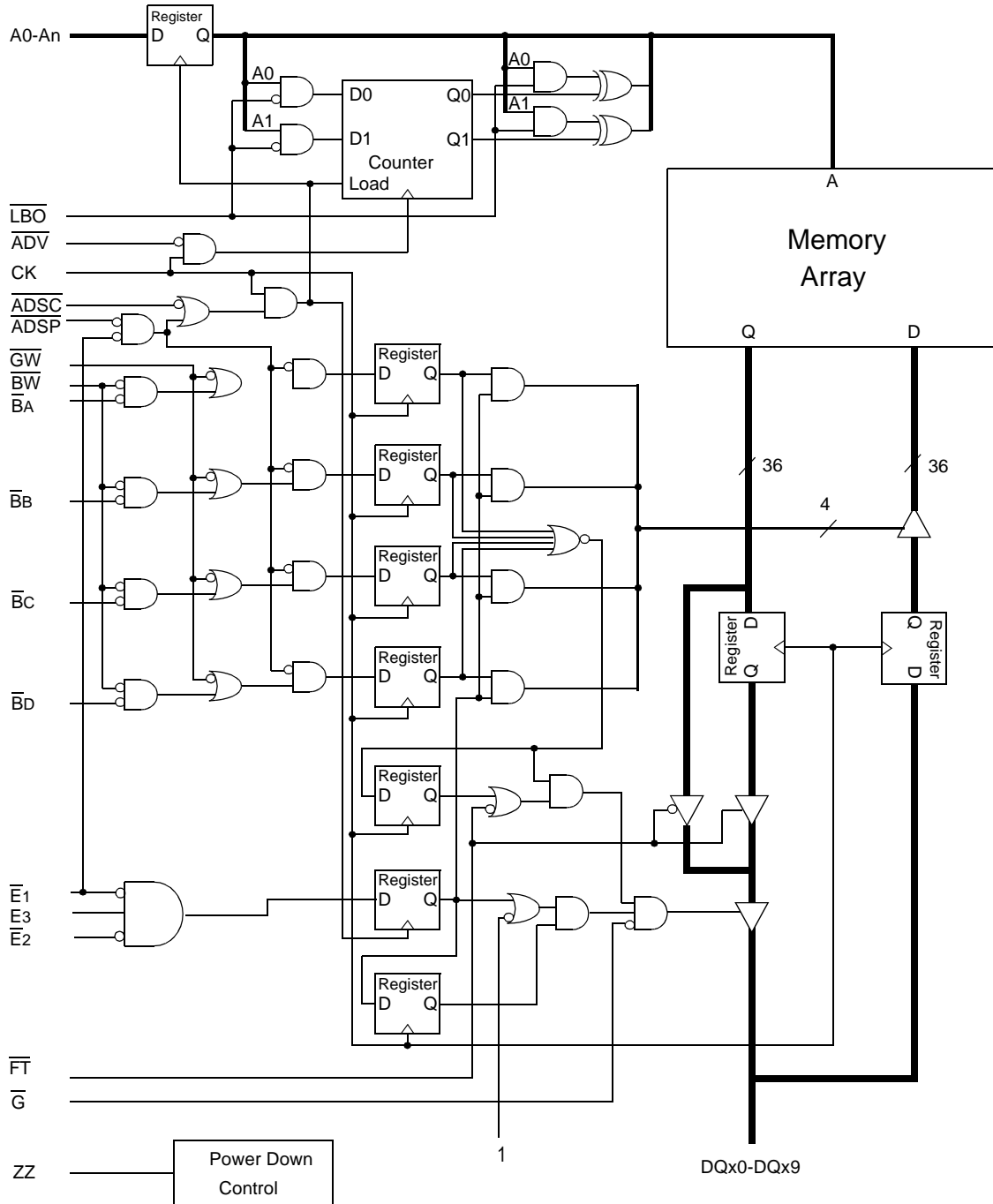

Note: Only x36 version shown for simplicity.

Mode Pin Functions

Mode Name	Pin Name	State	Function
Burst Order Control	$\overline{\text{LBO}}$	L	Linear Burst
		H or NC	Interleaved Burst
Output Register Control	$\overline{\text{FT}}$	L	Flow Through
		H or NC	Pipeline
Power Down Control	ZZ	L or NC	Active
		H	Standby, $I_{DD} = I_{SB}$

Note:

There are pull up devices on $\overline{\text{LBO}}$ and $\overline{\text{FT}}$ pins and a pull down device on the ZZ pin, so those input pins can be unconnected and the chip will operate in the default states as specified in the above tables.

Burst Counter Sequences
Linear Burst Sequence

	A[1:0]	A[1:0]	A[1:0]	A[1:0]
1st address	00	01	10	11
2nd address	01	10	11	00
3rd address	10	11	00	01
4th address	11	00	01	10

Note: The burst counter wraps to initial state on the 5th clock.

Interleaved Burst Sequence

	A[1:0]	A[1:0]	A[1:0]	A[1:0]
1st address	00	01	10	11
2nd address	01	00	11	10
3rd address	10	11	00	01
4th address	11	10	01	00

Note: The burst counter wraps to initial state on the 5th clock.

Byte Write Truth Table

Function	$\overline{\text{GW}}$	$\overline{\text{BW}}$	$\overline{\text{B}}_A$	$\overline{\text{B}}_B$	$\overline{\text{B}}_C$	$\overline{\text{B}}_D$	Notes
Read	H	H	X	X	X	X	1
Read	H	L	H	H	H	H	1
Write byte A	H	L	L	H	H	H	2, 3
Write byte B	H	L	H	L	H	H	2, 3
Write byte c	H	L	H	H	L	H	2, 3, 4
Write byte D	H	L	H	H	H	L	2, 3, 4
Write all bytes	H	L	L	L	L	L	2, 3, 4
Write all bytes	L	X	X	X	X	X	

Note:

1. All byte outputs are active in read cycles regardless of the state of Byte Write Enable inputs.
2. Byte Write Enable inputs $\overline{\text{B}}_A$, $\overline{\text{B}}_B$, $\overline{\text{B}}_C$ and/or $\overline{\text{B}}_D$ may be used in any combination with $\overline{\text{BW}}$ to write single or multiple bytes.
3. All byte I/Os remain High-Z during all write operations regardless of the state of Byte Write Enable inputs.
4. Bytes c and d are only available on the x32 and x36 versions.

Synchronous Truth Table

Operation	Address Used	State Diagram Key ⁵	\bar{E}_1	E^2	\overline{ADSP}	\overline{ADSC}	\overline{ADV}	W^3	DQ^4
Deselect Cycle, Power Down	None	X	H	X	X	L	X	X	High-Z
Deselect Cycle, Power Down	None	X	L	F	L	X	X	X	High-Z
Deselect Cycle, Power Down	None	X	L	F	H	L	X	X	High-Z
Read Cycle, Begin Burst	External	R	L	T	L	X	X	X	Q
Read Cycle, Begin Burst	External	R	L	T	H	L	X	F	Q
Write Cycle, Begin Burst	External	W	L	T	H	L	X	T	D
<i>Read Cycle, Continue Burst</i>	<i>Next</i>	<i>CR</i>	<i>X</i>	<i>X</i>	<i>H</i>	<i>H</i>	<i>L</i>	<i>F</i>	<i>Q</i>
Read Cycle, Continue Burst	Next	CR	H	X	X	H	L	F	Q
<i>Write Cycle, Continue Burst</i>	<i>Next</i>	<i>CW</i>	<i>X</i>	<i>X</i>	<i>H</i>	<i>H</i>	<i>L</i>	<i>T</i>	<i>D</i>
Write Cycle, Continue Burst	Next	CW	H	X	X	H	L	T	D
Read Cycle, Suspend Burst	Current		X	X	H	H	H	F	Q
Read Cycle, Suspend Burst	Current		H	X	X	H	H	F	Q
Write Cycle, Suspend Burst	Current		X	X	H	H	H	T	D
Write Cycle, Suspend Burst	Current		H	X	X	H	H	T	D

Note:

1. X = Don't Care, H = High, L = Low.
2. E = T (True) if $E_2 = 1$ and $\bar{E}_3 = 0$; E = F (False) if $E_2 = 0$ or $\bar{E}_3 = 1$.
3. \bar{W} = T (True) and F (False) is defined in the Byte Write Truth Table preceding.
4. \bar{G} is an asynchronous input. \bar{G} can be driven high at any time to disable active output drivers. \bar{G} low can only enable active drivers (shown as Q in the Truth Table above).
5. All input combinations shown above are tested and supported. Input combinations shown in gray boxes need not be used to accomplish basic synchronous or synchronous burst operations and may be avoided for simplicity.
6. Tying \overline{ADSP} high and \overline{ADSC} low allows simple non-burst synchronous operations. See **BOLD** items above.
7. Tying \overline{ADSP} high and \overline{ADV} low while using \overline{ADSC} to load new addresses allows simple burst operations. See *ITALIC* items above.

Simplified State Diagram

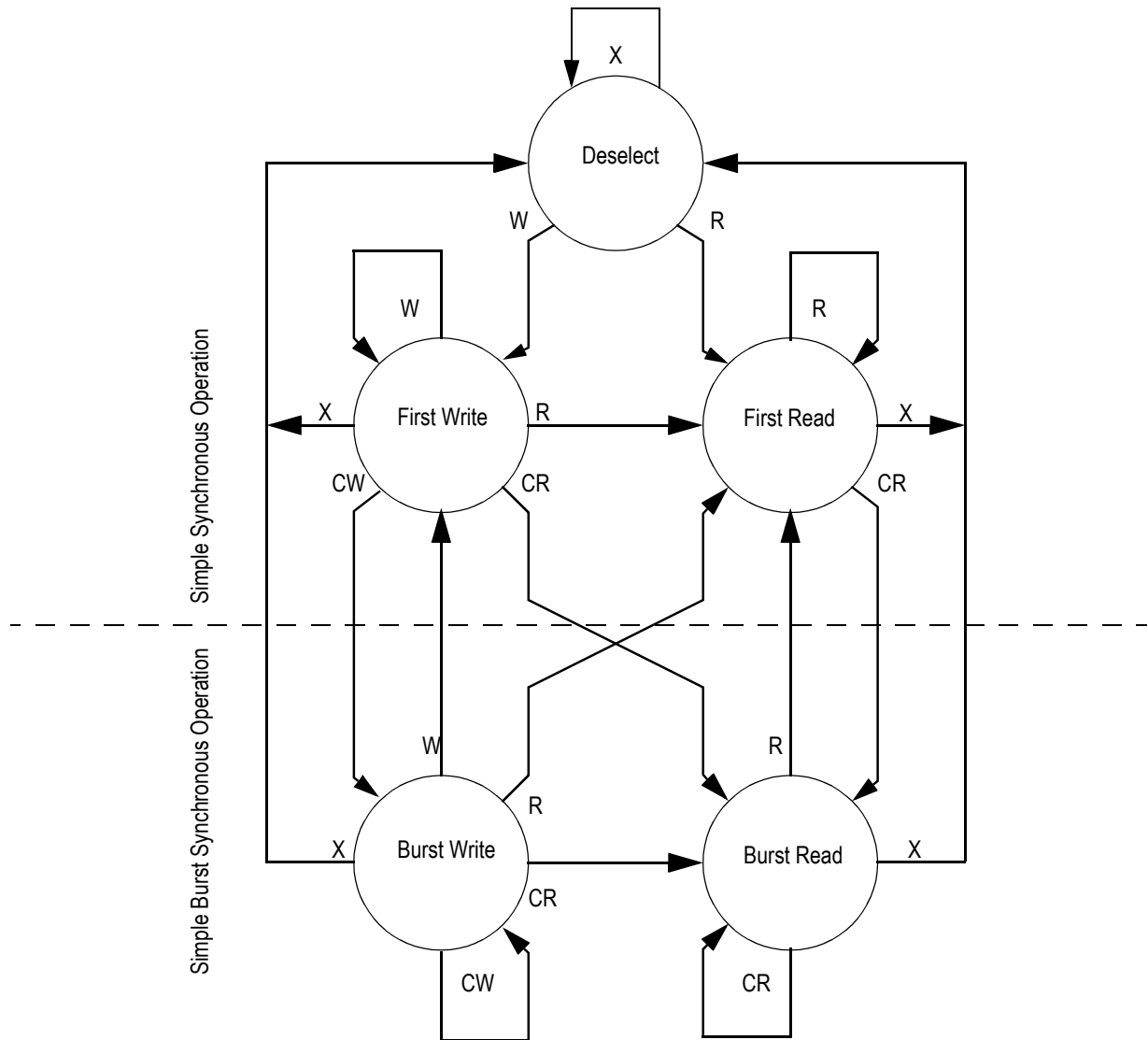

Notes:

1. The diagram shows only supported (tested) synchronous state transitions. The diagram presumes \overline{G} is tied Low.
2. The upper portion of the diagram assumes active use of only the Enable ($\overline{E}_1, \overline{E}_2, \overline{E}_3$) and Write ($\overline{B}_A, \overline{B}_B, \overline{B}_C, \overline{B}_D, \overline{B}_W$ and \overline{G}_W) control inputs and that ADSP is tied high and ADSC is tied low.
3. The upper and lower portions of the diagram together assume active use of only the Enable, Write and \overline{ADSC} control inputs and assumes ADSP is tied high and ADV is tied low.

Simplified State Diagram with \overline{G}

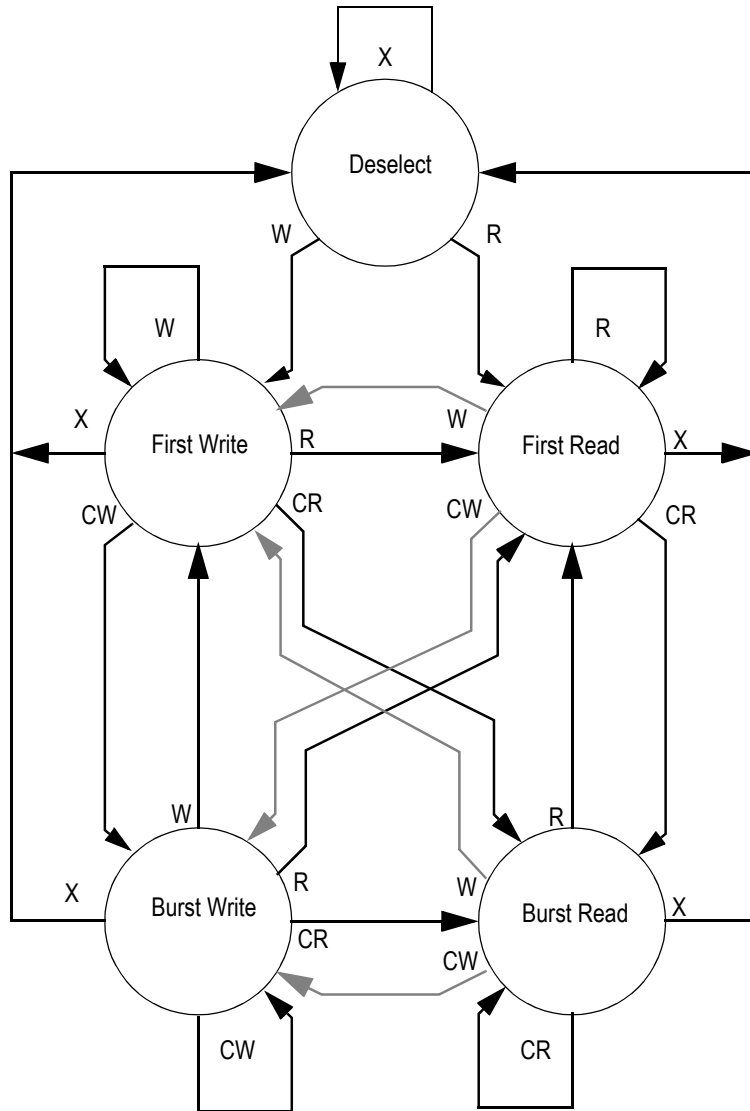

Notes:

1. The diagram shows supported (tested) synchronous state transitions plus supported transitions that depend upon the use of \overline{G} .
2. Use of Dummy Reads (Read Cycles with \overline{G} High) may be used to make the transition from Read cycles to Write cycles without passing through a Deselect cycle. Dummy Read cycles increment the address counter just like normal Read cycles.
3. Transitions shown in grey tone assume \overline{G} has been pulsed high long enough to turn the RAM's drivers off and for incoming data to meet Data Input Set Up Time.

Absolute Maximum Ratings

 (All voltages reference to V_{SS})

Symbol	Description	Value	Unit
V_{DD}	Voltage on V_{DD} Pins	-0.5 to 4.6	V
V_{DDQ}	Voltage in V_{DDQ} Pins	-0.5 to V_{DD}	V
V_{CK}	Voltage on Clock Input Pin	-0.5 to 6	V
$V_{I/O}$	Voltage on I/O Pins	-0.5 to $V_{DDQ}+0.5$ (≤ 4.6 V max.)	V
V_{IN}	Voltage on Other Input Pins	-0.5 to $V_{DD}+0.5$ (≤ 4.6 V max.)	V
I_{IN}	Input Current on Any Pin	+/- 20	mA
I_{OUT}	Output Current on Any I/O Pin	+/- 20	mA
P_D	Package Power Dissipation	1.5	W
T_{STG}	Storage Temperature	-55 to 125	$^{\circ}C$
T_{BIAS}	Temperature Under Bias	-55 to 125	$^{\circ}C$

Note:

Permanent damage to the device may occur if the Absolute Maximum Ratings are exceeded. Operation should be restricted to Recommended Operating Conditions. Exposure to conditions exceeding the Absolute Maximum Ratings, for an extended period of time, may affect reliability of this component.

Recommended Operating Conditions

Parameter	Symbol	Min.	Typ.	Max.	Unit	Notes
Supply Voltage	V_{DD}	3.135	3.3	3.6	V	
I/O Supply Voltage	V_{DDQ}	2.375	2.5	V_{DD}	V	1
Input High Voltage	V_{IH}	1.7	---	$V_{DD}+0.3$	V	2
Input Low Voltage	V_{IL}	-0.3	---	0.8	V	2
Ambient Temperature (Commercial Range Versions)	T_A	0	25	70	$^{\circ}C$	3
Ambient Temperature (Industrial Range Versions)	T_A	-40	25	85	$^{\circ}C$	3

Note:

1. Unless otherwise noted, all performance specifications quoted are evaluated for worst case at both $2.75V \leq V_{DDQ} \leq 2.375V$ (i.e. 2.5V I/O) and $3.6V \leq V_{DD} \leq 3.135V$ (i.e. 3.3V I/O) and quoted at whichever condition is worst case.
2. This device features input buffers compatible with both 3.3V and 2.5V I/O drivers.
3. Most speed grades and configurations of this device are offered in both Commercial and Industrial Temperature ranges. The part number of Industrial Temperature Range versions end the character I. Unless otherwise noted, all performance specifications quoted are evaluated for worst case in the temperature range marked on the device.
4. Input Under/overshoot voltage must be $-2V > V_i < V_{DD}+2V$ with a pulse width not to exceed 20% tKC.

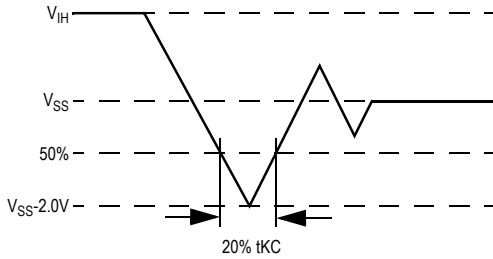
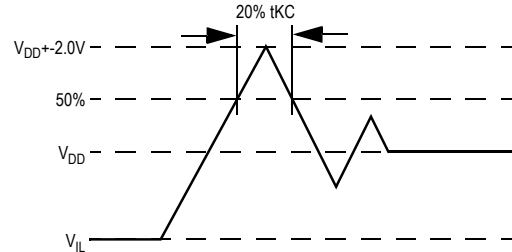
Undershoot Measurement and Timing

Overshoot Measurement and Timing

Capacitance

($T_A=25^\circ\text{C}$, $f=1\text{MHz}$, $V_{DD}=3.3\text{V}$)

Parameter	Symbol	Test conditions	Typ.	Max.	Unit
Control Input Capacitance	C_I	$V_{DD}=3.3\text{V}$	3	4	pF
Input Capacitance	C_{IN}	$V_{IN}=0\text{V}$	4	5	pF
Output Capacitance	C_{OUT}	$V_{OUT}=0\text{V}$	6	7	pF

Note: This parameter is sample tested.

Package Thermal Characteristics

Rating	Layer Board	Symbol	TQFP Max	BGA Max	Unit	Notes
Junction to Ambient (at 200 lfm)	single	$R_{\Theta JA}$	40	38	$^\circ\text{C/W}$	1,2,4
Junction to Ambient (at 200 lfm)	four	$R_{\Theta JA}$	24	21	$^\circ\text{C/W}$	1,2,4
Junction to Case (TOP)		$R_{\Theta JC}$	9	5	$^\circ\text{C/W}$	3,4

Notes:

Notes:

- Junction temperature is a function of SRAM power dissipation, package thermal resistance, mounting board temperature, ambient. Temperature air flow, board density, and PCB thermal resistance.
- SCMI G-38-87.
- Average thermal resistance between die and top surface, MIL SPEC-883, Method 1012.1.
- For x18 configuration, consult factory.

AC Test Conditions

Parameter	Conditions
Input high level	2.3V
Input low level	0.2V
Input slew rate	1V/ns
Input reference level	1.25V
Output reference level	1.25V
Output load	Fig. 1 & 2

Notes:

1. Include scope and jig capacitance.
2. Test conditions as specified with output loading as shown in Fig. 1 unless otherwise noted.
3. Output Load 2 for t_{LZ} , t_{HZ} , t_{OLZ} and t_{OHZ} .
4. Device is deselected as defined by the Truth Table.

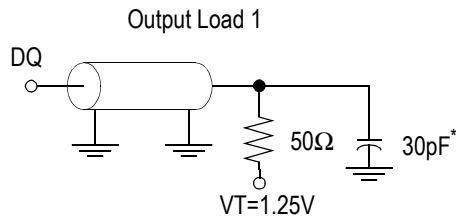

* Distributed Test Jig Capacitance

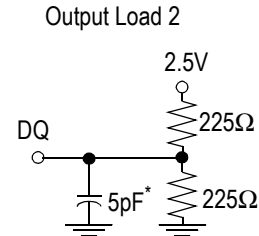
DC Electrical Characteristics

Parameter	Symbol	Test Conditions	Min	Max
Input Leakage Current (except mode pins)	I_{IL}	$V_{IN} = 0$ to V_{DD}	-1 μ A	1 μ A
ZZ Input Current	I_{INZZ}	$V_{DD} \geq V_{IN} \geq V_{IH}$ $0V \leq V_{IN} \leq V_{IH}$	-1 μ A -1 μ A	1 μ A 300 μ A
Mode Pin Input Current	I_{INM}	$V_{DD} \geq V_{IN} \geq V_{IL}$ $0V \leq V_{IN} \leq V_{IL}$	-300 μ A -1 μ A	1 μ A 1 μ A
Output Leakage Current	I_{OL}	Output Disable, $V_{OUT} = 0$ to V_{DD}	-1 μ A	1 μ A
Output High Voltage	V_{OH}	$I_{OH} = -8mA$, $V_{DDQ} = 2.375V$	1.7V	
Output High Voltage	V_{OH}	$I_{OH} = -8mA$, $V_{DDQ} = 3.135V$	2.4V	
Output Low Voltage	V_{OL}	$I_{OL} = 8mA$		0.4V

Operating Currents

Parameter	Test Conditions	Symbol	-180		-166		-150		-100	
			0 to 70°C	-40 to 85°C	0 to 70°C	-40 to 85°C	0 to 70°C	-40 to 85°C	0 to 70°C	-40 to 85°C
Operating Current	Device Selected; All other inputs $\geq V_{IH}$ or $\leq V_{IL}$ Output open	I_{DD} Pipeline	330mA	340mA	310mA	320mA	275mA	285mA	190mA	200mA
		I_{DD} Flow-Thru	190mA	200mA	190mA	200mA	190mA	200mA	140mA	150mA
Standby Current	$ZZ \geq V_{DD} - 0.2V$	I_{SB} Pipeline	30mA	40mA	30mA	40mA	30mA	40mA	30mA	40mA
		I_{SB} Flow-Thru	30mA	40mA	30mA	40mA	30mA	40mA	30mA	40mA
Deselect Current	Device Deselected; All other inputs $\geq V_{IH}$ or $\leq V_{IL}$	I_{DD} Pipeline	120mA	130mA	110mA	120mA	105mA	115mA	80mA	90mA
		I_{DD} Flow-Thru	80mA	90mA	80mA	90mA	80mA	90mA	65mA	75mA

AC Electrical Characteristics

	Parameter	Symbol	-180		-166		-150		-100		Unit
			Min	Max	Min	Max	Min	Max	Min	Max	
Pipeline	Clock Cycle Time	t _{KC}	5.5	---	6.0	---	6.7	---	10	---	ns
	Clock to Output Valid	t _{KQ}	---	3.2	---	3.5	---	3.8	---	4.5	ns
	Clock to Output Invalid	t _{KQX}	1.5	---	1.5	---	1.5	---	1.5	---	ns
	Clock to Output in Low-Z	t _{LZ} ¹	1.5	---	1.5	---	1.5	---	1.5	---	ns
Flow-Thru	Clock Cycle Time	t _{KC}	10.0	---	10.0	---	10.0	---	15.0	---	ns
	Clock to Output Valid	t _{KQ}	---	8.0	---	8.5	---	10.0	---	12.0	ns
	Clock to Output Invalid	t _{KQX}	3.0	---	3.0	---	3.0	---	3.0	---	ns
	Clock to Output in Low-Z	t _{LZ} ¹	3.0	---	3.0	---	3.0	---	3.0	---	ns
	Clock HIGH Time	t _{KH}	1.3	---	1.3	---	1.5	---	2	---	ns
	Clock LOW Time	t _{KL}	1.5	---	1.5	---	1.7	---	2.2	---	ns
	Clock to Output in High-Z	t _{HZ} ¹	1.5	3.2	1.5	3.5	1.5	3.8	1.5	5	ns
	\bar{G} to Output Valid	t _{OE}	---	3.2	---	3.5	---	3.8	---	5	ns
	\bar{G} to output in Low-Z	t _{OLZ} ¹	0	---	0	---	0	---	0	---	ns
	\bar{G} to output in High-Z	t _{OHZ} ¹	---	3.2	---	3.5	---	3.8	---	5	ns
	Setup time	t _S	1.5	---	1.5	---	1.5	---	2.0	---	ns
	Hold time	t _H	0.5	---	0.5	---	0.5	---	0.5	---	ns
	ZZ setup time	t _{ZZS} ²	5	---	5	---	5	---	5	---	ns
	ZZ hold time	t _{ZZH} ²	1	---	1	---	1	---	1	---	ns
	ZZ recovery	t _{ZZR}	20	---	20	---	20	---	20	---	ns

Notes:

1. These parameters are sampled and are not 100% tested
2. ZZ is an asynchronous signal. However, In order to be recognized on any given clock cycle, ZZ must meet the specified setup and hold times as specified above.

Write Cycle Timing

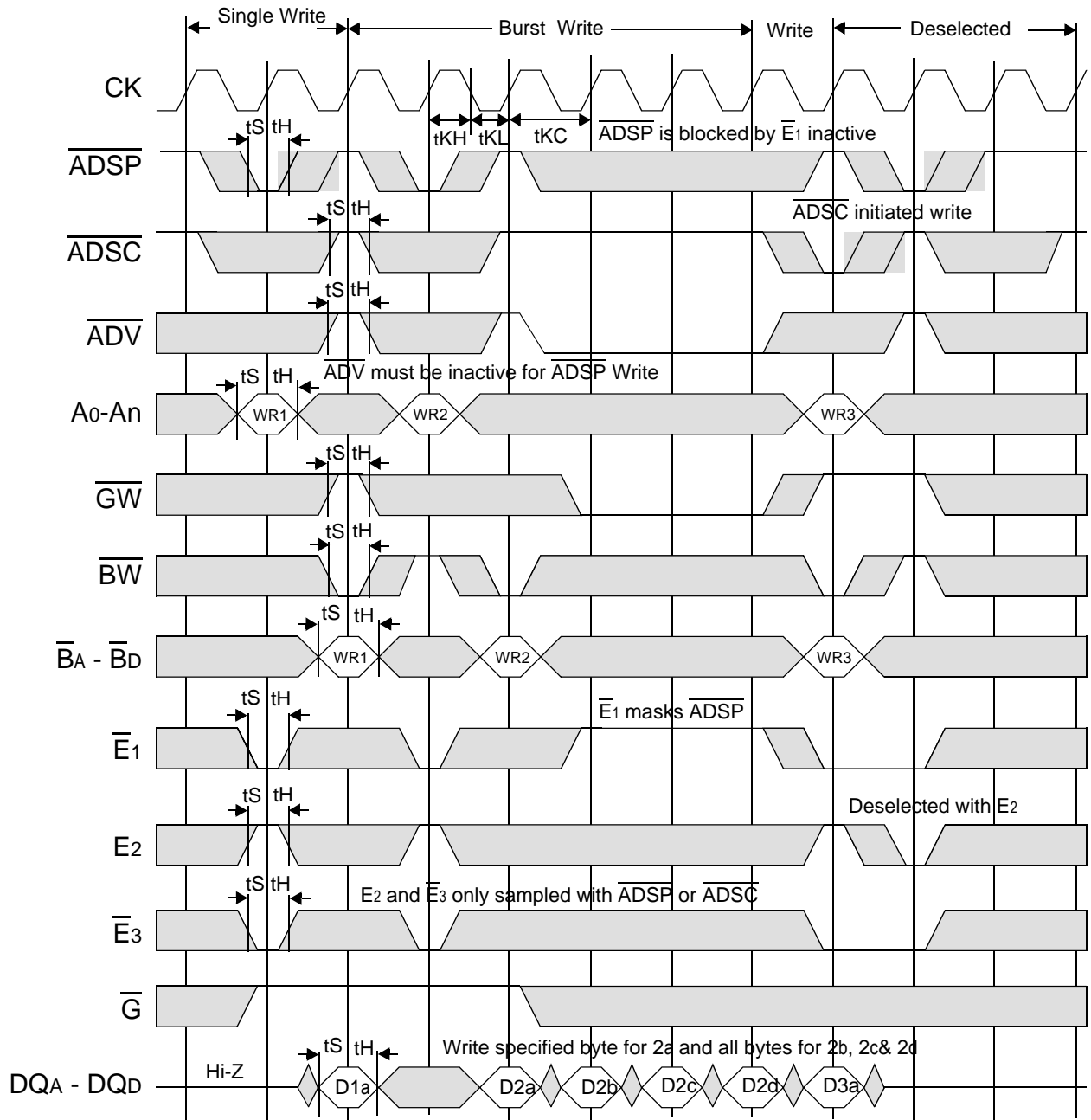

Flow Through Read Cycle Timing

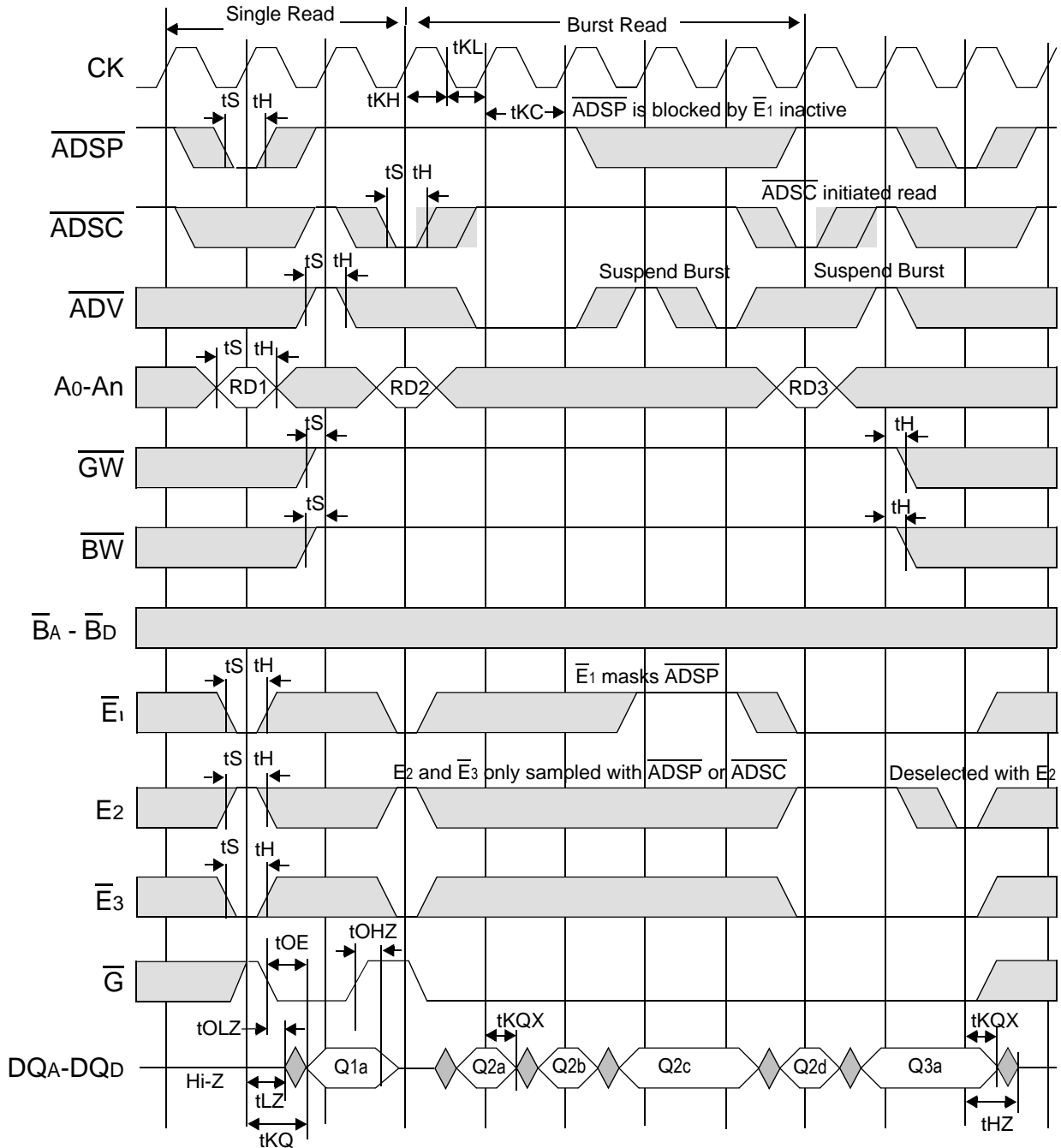

Flow Through Read-Write Cycle Timing

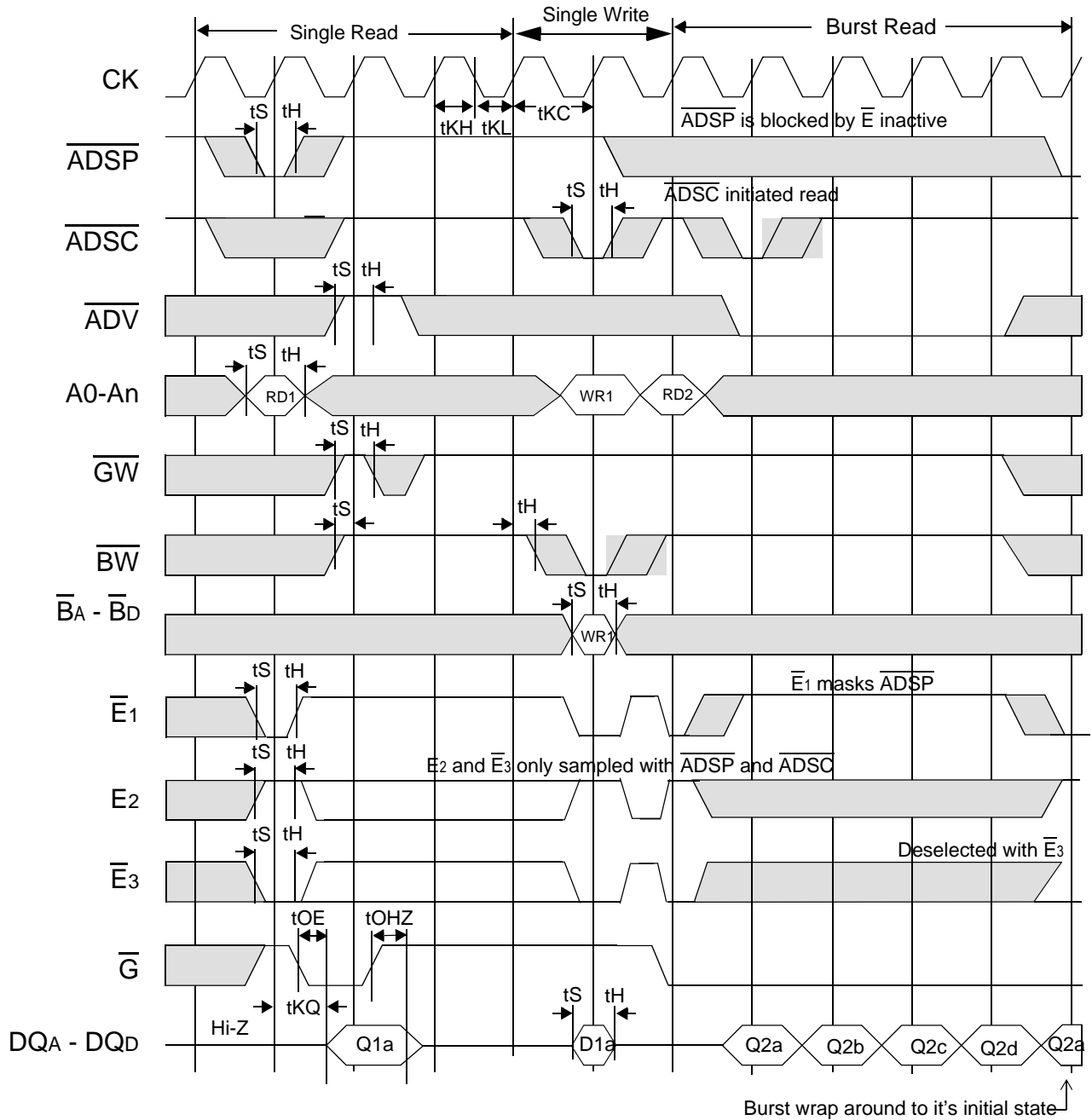

Pipelined SCD Read Cycle Timing

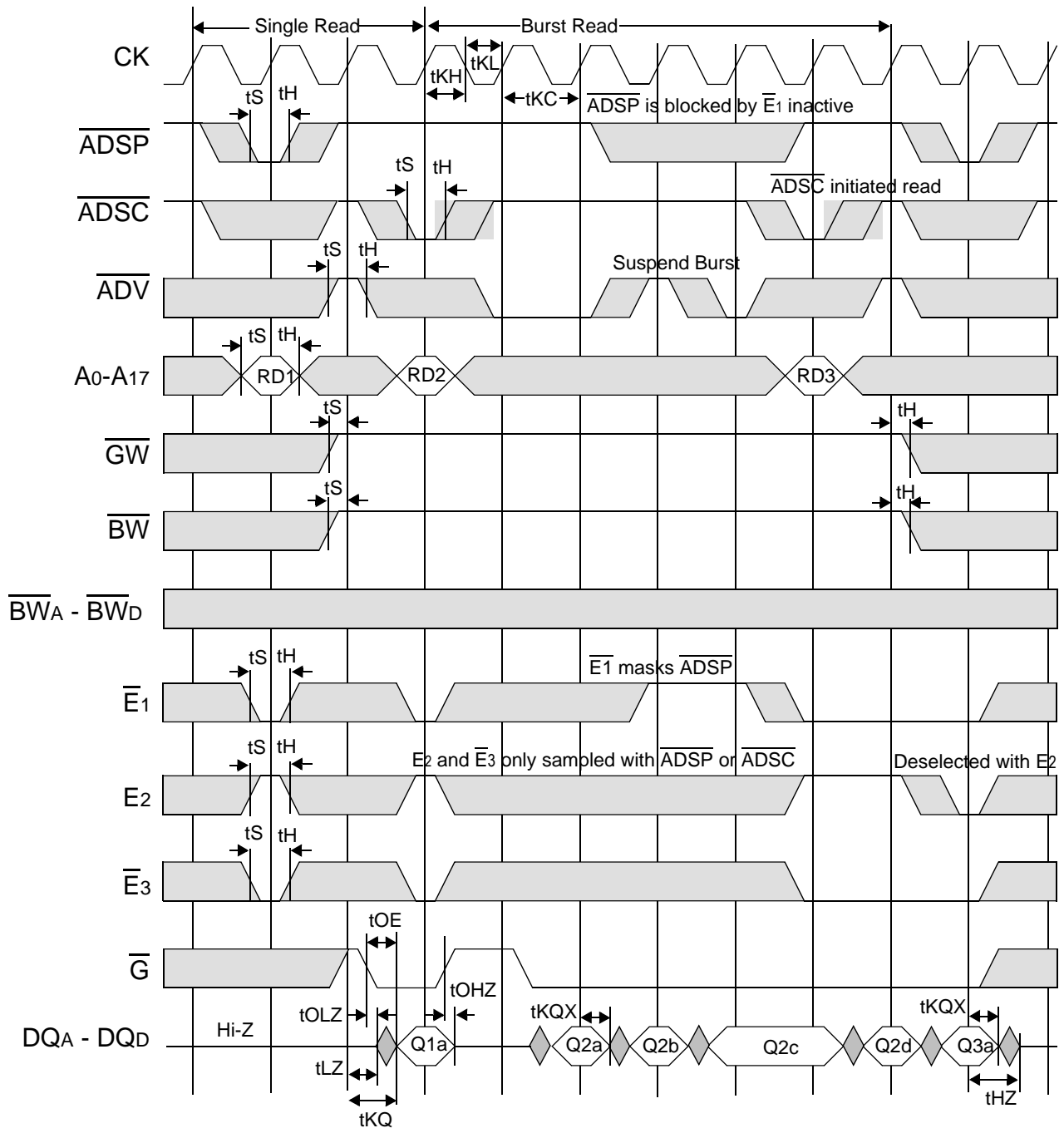

Pipelined SCD Read - Write Cycle Timing

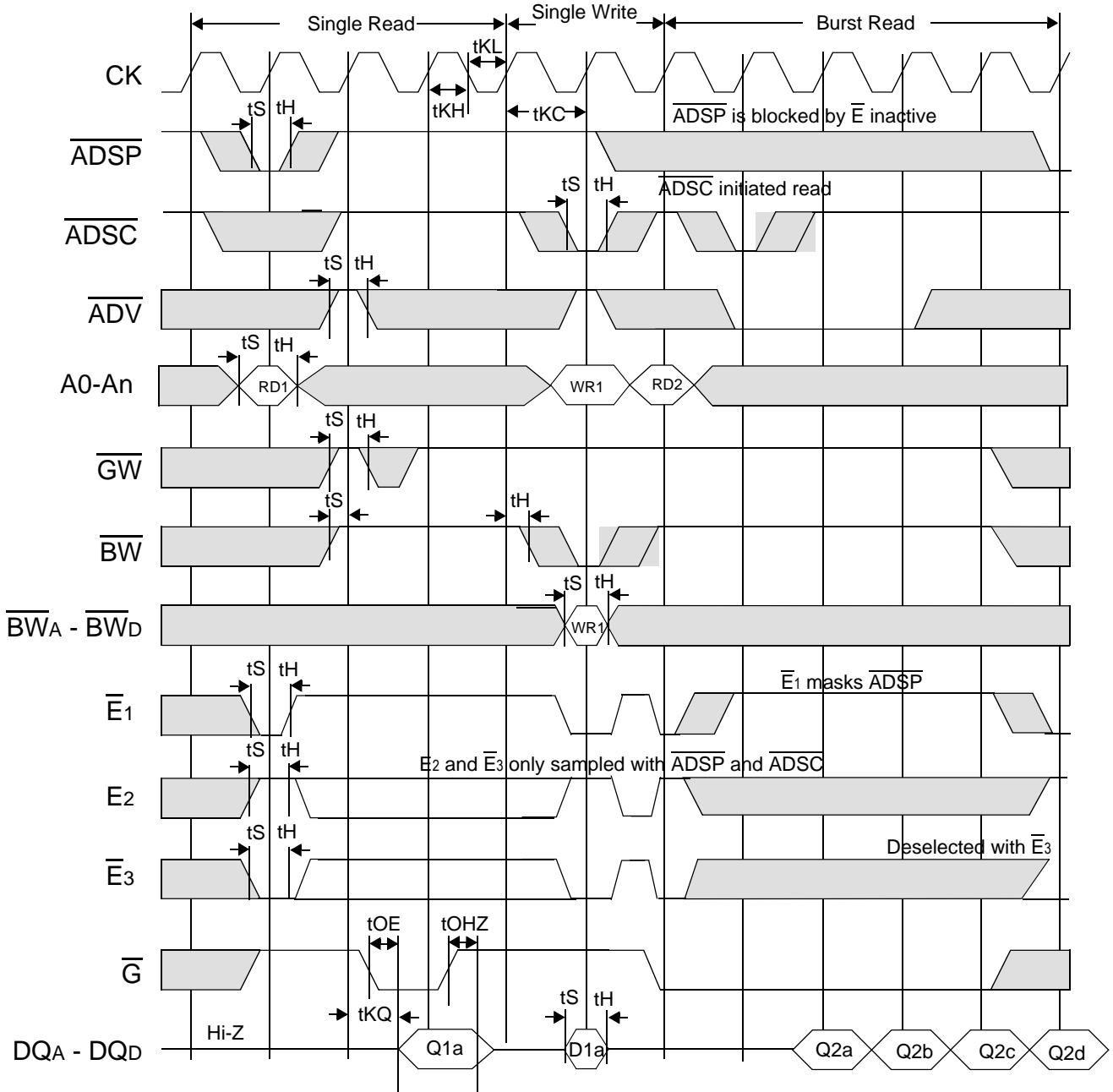

Sleep Mode Timing Diagram

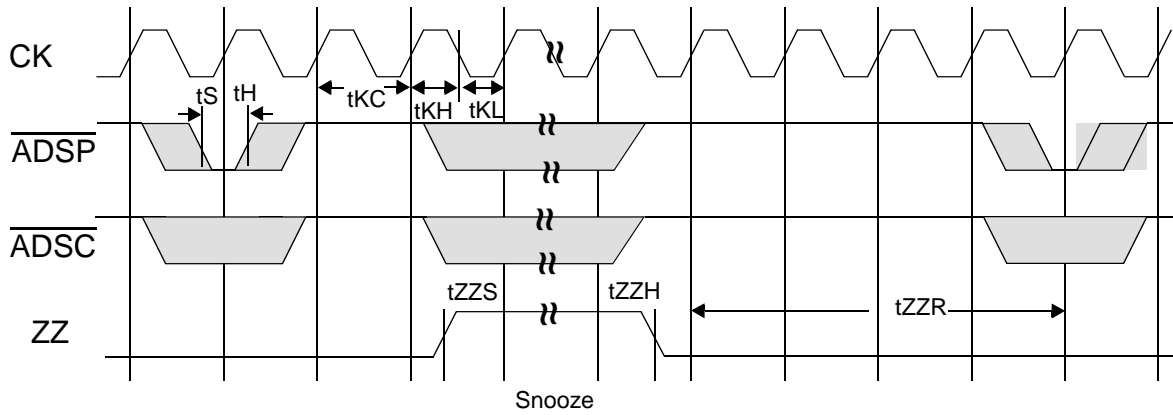

Application Tips

Single and Dual Cycle Deselect

SCD devices force the use of dummy read cycles (read cycles that are launched normally but that are ended with the output drivers inactive) in a fully synchronous environment. Dummy read cycles waste performance but their use usually assures there will be no bus contention in transitions from reads to writes or between banks of RAMs. DCD SRAMs do not waste bandwidth on dummy cycles and are logically simpler to manage in a multiple bank application (wait states need not be inserted at bank address boundary crossings) but greater care must be exercised to avoid excessive bus contention.

GS 840H18/32/36 Output Driver Characteristics

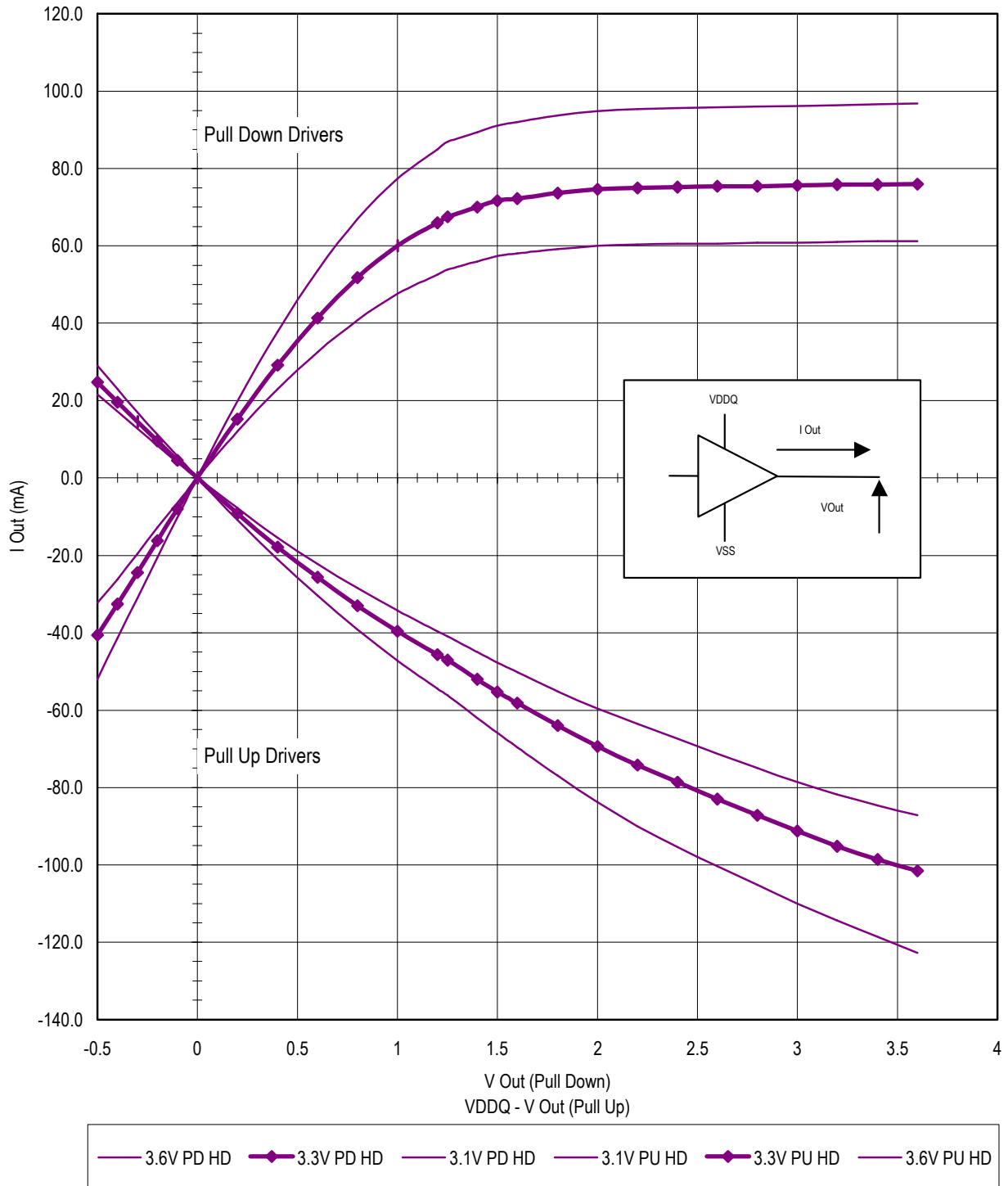

TQFP Package Drawing

Symbol	Description	Min.	Nom.	Max
A1	Standoff	0.05	0.10	0.15
A2	Body Thickness	1.35	1.40	1.45
b	Lead Width	0.20	0.30	0.40
c	Lead Thickness	0.09		0.20
D	Terminal Dimension	21.9	22.0	22.1
D1	Package Body	19.9	20.0	20.1
E	Terminal Dimension	15.9	16.0	16.1
E1	Package Body	13.9	14.0	14.1
e	Lead Pitch		0.65	
L	Foot Length	0.45	0.60	0.75
L1	Lead Length		1.00	
Y	Coplanarity			0.10
θ	Lead Angle	0°		7°

Notes:

1. All dimensions are in millimeters (mm).
2. Package width and length do not include mold protrusion

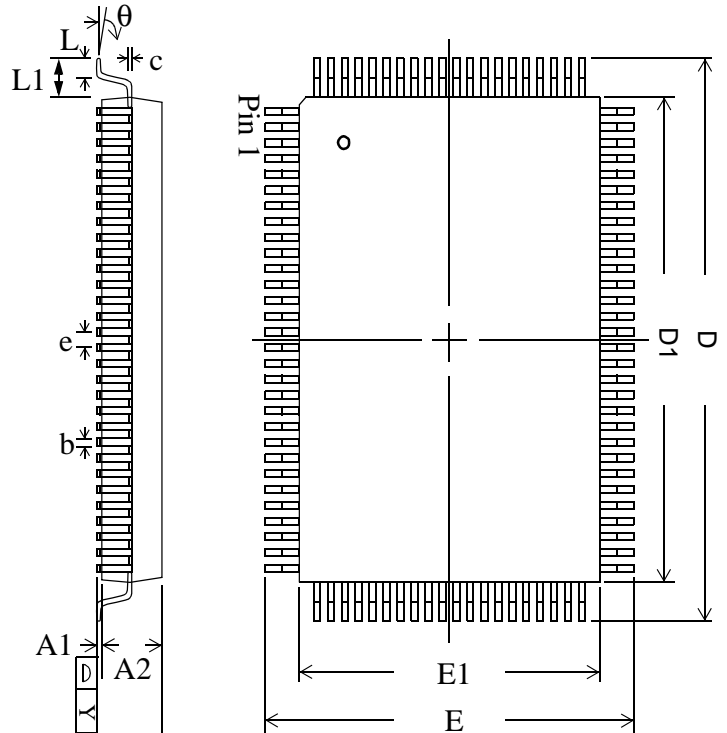

Package Dimensions - 119 Pin BGA

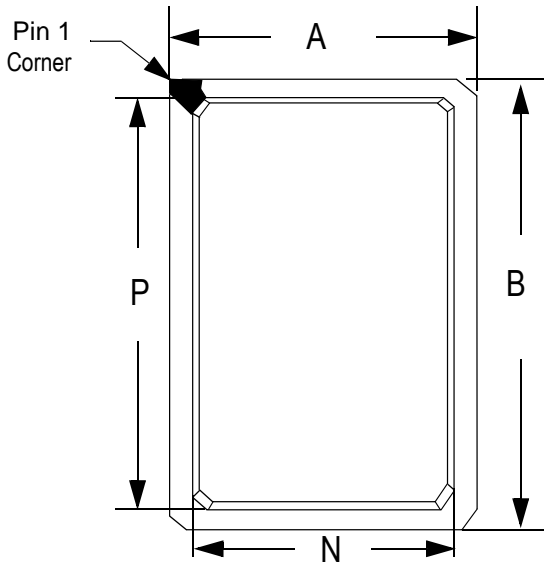

Top View

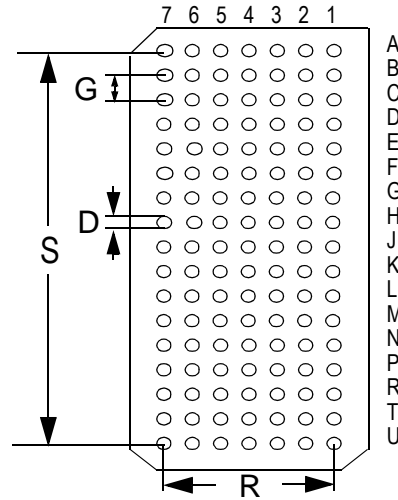

Bottom View

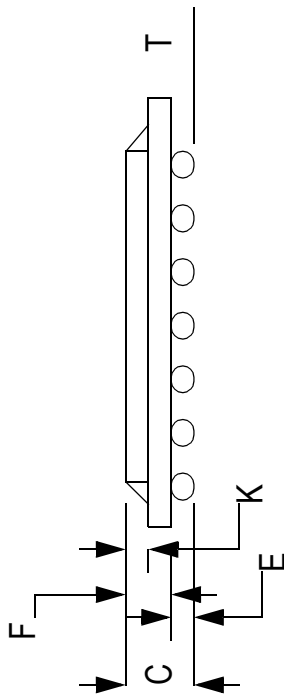

Side View

Package Dimensions - 119 Pin BGA

Symbol	Description	Min.	Nom.	Max
A	Width	13.8	14.0	14.2
B	Length	21.8	22.0	22.2
C	Package Height (including ball)	-		2.40
D	Ball Size	0.60	0.75	0.90
E	Ball Height	0.50	0.60	0.70
F	Package Height (excluding balls)		1.46	1.70
G	Width between Balls		1.27	
K	Package Height above board	0.80	0.90	1.00
N	Cut-out Package Width		12.00	
P	Foot Length		19.50	
R	Width of package between balls		7.62	
S	Length of package between balls		20.32	
T	Variance of Ball Height		0.15	

Unit: mm

Ordering Information for GSI Synchronous Burst RAMS

Org	Part Number ¹	Type	Package	Speed ² (Mhz/ ns)	T _A ³	Status
256K x 18	GS840H18T-180	Pipeline/Flow Through	TQFP	180/8	C	
256K x 18	GS840H18T-166	Pipeline/Flow Through	TQFP	166/8.5	C	
256K x 18	GS840H18T-150	Pipeline/Flow Through	TQFP	150/10	C	
256K x 18	GS840H18T-100	Pipeline/Flow Through	TQFP	100/12	C	
128K x 32	GS840H32T-180	Pipeline/Flow Through	TQFP	180/8	C	
128K x 32	GS840H32T-166	Pipeline/Flow Through	TQFP	166/8.5	C	
128K x 32	GS840H32T-150	Pipeline/Flow Through	TQFP	150/10	C	
128K x 32	GS840H32T-100	Pipeline/Flow Through	TQFP	100/12	C	
128K x 36	GS840H36T-180	Pipeline/Flow Through	TQFP	180/8	C	
128K x 36	GS840H36T-166	Pipeline/Flow Through	TQFP	166/8.5	C	
128K x 36	GS840H36T-150	Pipeline/Flow Through	TQFP	150/10	C	
128K x 36	GS840H36T-100	Pipeline/Flow Through	TQFP	100/12	C	
256K x 18	GS840H18T-180I	Pipeline/Flow Through	TQFP	180/8	I	Not Available
256K x 18	GS840H18T-166I	Pipeline/Flow Through	TQFP	166/8.5	I	
256K x 18	GS840H18T-150I	Pipeline/Flow Through	TQFP	150/10	I	
256K x 18	GS840H18T-100I	Pipeline/Flow Through	TQFP	100/12	I	
128K x 32	GS840H32T-180I	Pipeline/Flow Through	TQFP	180/8	I	Not Available
128K x 32	GS840H32T-166I	Pipeline/Flow Through	TQFP	166/8.5	I	
128K x 32	GS840H32T-150I	Pipeline/Flow Through	TQFP	150/10	I	
128K x 32	GS840H32T-100I	Pipeline/Flow Through	TQFP	100/12	I	
128K x 36	GS840H36T-180I	Pipeline/Flow Through	TQFP	180/8	I	Not Available
128K x 36	GS840H36T-166I	Pipeline/Flow Through	TQFP	166/8.5	I	
128K x 36	GS840H36T-150I	Pipeline/Flow Through	TQFP	150/10	I	
128K x 36	GS840H36T-100I	Pipeline/Flow Through	TQFP	100/12	I	
256K x 18	GS840H18B-180	Pipeline/Flow Through	BGA	180/8	C	
256K x 18	GS840H18B-166	Pipeline/Flow Through	BGA	166/8.5	C	
256K x 18	GS840H18B-150	Pipeline/Flow Through	BGA	150/10	C	
256K x 18	GS840H18B-100	Pipeline/Flow Through	BGA	100/12	C	
128K x 32	GS840H32B-180	Pipeline/Flow Through	BGA	180/8	C	

Notes:

- Customers requiring delivery in Tape and Reel should add the character T to the end of the part number. Example: GS84032T-7.5T.
- The speed column indicates the cycle frequency (Mhz) of the device in Pipelined mode and the latency (ns) in Flow Through mode. Each device is Pipeline / Flow through mode selectable by the user.
- T_A = C = Commercial Temperature Range. T_A = I = Industrial Temperature Range.
- GSI offers other versions this type of device in many different configurations and with a variety of different features, only some of which are covered in this data sheet. See the GSI Technology web site for a complete listing of current offerings.

Org	Part Number ¹	Type	Package	Speed ² (Mhz/ ns)	T _A ³	Status
128K x 32	GS840H32B-166	Pipeline/Flow Through	BGA	166/8.5	C	
128K x 32	GS840H32B-150	Pipeline/Flow Through	BGA	150/10	C	
128K x 32	GS840H32B-100	Pipeline/Flow Through	BGA	100/12	C	
128K x 36	GS840H36B-180	Pipeline/Flow Through	BGA	180/8	C	
128K x 36	GS840H36B-166	Pipeline/Flow Through	BGA	166/8.5	C	
128K x 36	GS840H36B-150	Pipeline/Flow Through	BGA	150/10	C	
128K x 36	GS840H36B-100	Pipeline/Flow Through	BGA	100/12	C	
256K x 18	GS840H18B-180I	Pipeline/Flow Through	BGA	180/8	I	Not Available
256K x 18	GS840H18B-166I	Pipeline/Flow Through	BGA	166/8.5	I	
256K x 18	GS840H18B-150I	Pipeline/Flow Through	BGA	150/10	I	
256K x 18	GS840H18B-100I	Pipeline/Flow Through	BGA	100/12	I	
128K x 32	GS840H32B-180I	Pipeline/Flow Through	BGA	180/8	I	Not Available
128K x 32	GS840H32B-166I	Pipeline/Flow Through	BGA	166/8.5	I	
128K x 32	GS840H32B-150I	Pipeline/Flow Through	BGA	150/10	I	
128K x 32	GS840H32B-100I	Pipeline/Flow Through	BGA	100/12	I	
128K x 36	GS840H36B-180I	Pipeline/Flow Through	BGA	180/8	I	Not Available
128K x 36	GS840H36B-166I	Pipeline/Flow Through	BGA	166/8.5	I	
128K x 36	GS840H36B-150I	Pipeline/Flow Through	BGA	150/10	I	
128K x 36	GS840H36B-100I	Pipeline/Flow Through	BGA	100/12	I	

Notes:

- Customers requiring delivery in Tape and Reel should add the character T to the end of the part number. Example: GS84032T-7.5T.
- The speed column indicates the cycle frequency (Mhz) of the device in Pipelined mode and the latency (ns) in Flow Through mode. Each device is Pipeline / Flow through mode selectable by the user.
- T_A = C = Commercial Temperature Range. T_A = I = Industrial Temperature Range.
- GSI offers other versions this type of device in many different configurations and with a variety of different features, only some of which are covered in this data sheet. See the GSI Technology web site for a complete listing of current offerings.

Revision History

Rev. Code: Old; New	Types of Changes Format or Content	Page /Revisions;Reason
GS840H18/32/36 Rev 1.02c 5/ 1999; GS840H18/32/36 2.00 8/1999D	Format/Typos	Document/Continued changing to new format.
	Content	Added Fine Pitch BGA Package.
GS840H18/32/362.00 8/ 1999;GS840H18/32/362.01 9/ 1999E	Format/Typos	Took E out of 840HE...in Core and Interface Voltages. Pin outs/New small caps format. Timing Diagrams/New format. Block Diagrams/New small caps format.
	Content	Pin outs/x32 & x36 TQFP/Changed pin 72 from DQA3 to DQB3. Pin Description/Rearranged Address Inputs to match order on TQFP Pinout. TQFP Package Diagram/Corrected Dimension D Max from 20.1 to 22.1. Corrected ordering information.
GS840H18/32/362.01 9/ 1999E;GS840H18/32/362.02		Took out Fine Pitch BGA Package. Package change in progress.
GS840H18/32/362.0210-11/ 1999;GS840H18/32/362.032/ 2000G	Format	New GSI Logo Took Pin out of heading for consistency.
GS840E18/32/362.032/2000G; 840H18_r2_04	Content	Updated BGA pin description table to meet JEDEC standard