

TQFP, BGA
Commercial Temp
Industrial Temp

256K x 18 Sync Cache Tag

166 MHz–100 MHz
8.5 ns–12 ns
3.3 V V_{DD}
3.3 V and 2.5 V I/O

Features

- 3.3 V +10%/–5% core power supply, 2.5 V or 3.3 V I/O supply
- Integrated data comparator for Tag RAM application
- FT mode pin for flow through or pipeline operation
- $\overline{\text{LBO}}$ pin for Linear or Interleave (Pentium™ and X86) Burst mode
- Synchronous address, data I/O, and control inputs
- Synchronous Data Enable ($\overline{\text{DE}}$)
- Asynchronous Output Enable ($\overline{\text{OE}}$)
- Asynchronous Match Output Enable ($\overline{\text{MOE}}$)
- Byte Write ($\overline{\text{BWE}}$) and Global Write ($\overline{\text{GW}}$) operation
- Three chip enable signals for easy depth expansion
- Internal self-timed write cycle
- JTAG Test mode conforms to IEEE standard 1149.1
- JEDEC-standard 100-lead TQFP package and 119-BGA:
T: TQFP or B: BGA

		-166	-150	-133	-100
Pipeline 3-1-1-1	t_{cycle}	6.0 ns	6.6 ns	7.5 ns	10 ns
	t_{KQ}	3.5 ns	3.8 ns	4.0 ns	4.5 ns
	I_{DD}	310 mA	275 mA	250 mA	190 mA
Flow Through 2-1-1-1	t_{KQ}	8.5 ns	10 ns	11 ns	12 ns
	t_{cycle}	10 ns	10 ns	15 ns	15 ns
	I_{DD}	190 mA	190 mA	140 mA	140 mA

Functional Description

The GS84118 is a 256K x 18 high performance synchronous SRAM with integrated Tag RAM comparator. A 2-bit burst counter is included to provide burst interface with Pentium™ and other high performance CPUs. It is designed to be used as a Cache Tag SRAM, as well as data SRAM. Addresses, data I/Os, match output, chip enables ($\overline{\text{CE1}}$, $\overline{\text{CE2}}$, $\overline{\text{CE3}}$), address control inputs ($\overline{\text{ADSP}}$, $\overline{\text{ADSC}}$, $\overline{\text{ADV}}$), and write control inputs ($\overline{\text{BW1}}$, $\overline{\text{BW2}}$, $\overline{\text{BWE}}$, $\overline{\text{GW}}$, $\overline{\text{DE}}$) are synchronous and are controlled by a positive-edge-triggered clock (CLK).

Output Enable ($\overline{\text{OE}}$), Match Output Enable, and power down control ($\overline{\text{ZZ}}$) are asynchronous. Burst can be initiated with either $\overline{\text{ADSP}}$ or $\overline{\text{ADSC}}$ inputs. Subsequent burst addresses are generated internally and are controlled by $\overline{\text{ADV}}$. The burst sequence is either interleave order (Pentium™ or x86) or linear order, and is controlled by $\overline{\text{LBO}}$.

Output registers and the Match output register are provided and controlled by the $\overline{\text{FT}}$ mode pin (Pin 14). Through use of the $\overline{\text{FT}}$ mode pin, I/O registers can be programmed to perform pipeline or flow through operation. Flow Through mode reduces latency.

Byte write operation is performed by using Byte Write Enable ($\overline{\text{BWE}}$) input combined with two individual byte write signals $\overline{\text{BW1-2}}$. In addition, Global Write ($\overline{\text{GW}}$) is available for writing all bytes at one time.

Compare cycles begin as a read cycle with output disabled so that compare data can be loaded into the data input register. The comparator compares the read data with the registered input data and a match signal is generated. The match output can be either in Pipeline or Flow Through modes controlled by the $\overline{\text{FT}}$ signal.

Low power (Standby mode) is attained through the assertion of the $\overline{\text{ZZ}}$ signal, or by stopping the clock (CLK). Memory data is retained during Standby mode.

JTAG boundary scan interface is provided using IEEE standard 1149.1 protocol. Four pins—Test Data In (TDI), Test Data Out (TDO), Test Clock (TCK) and Test Mode Select (TMS)—are used to perform JTAG function.

The GS84118 operates on a 3.3 V power supply and all inputs/outputs are 3.3 V- or 2.5 V-LVTTL-compatible. Separate output (V_{DDQ}) pins are used to allow both 3.3 V or 2.5 V I/O interface.

* Pentium is a trademark of Intel Corp.

Pin Configuration

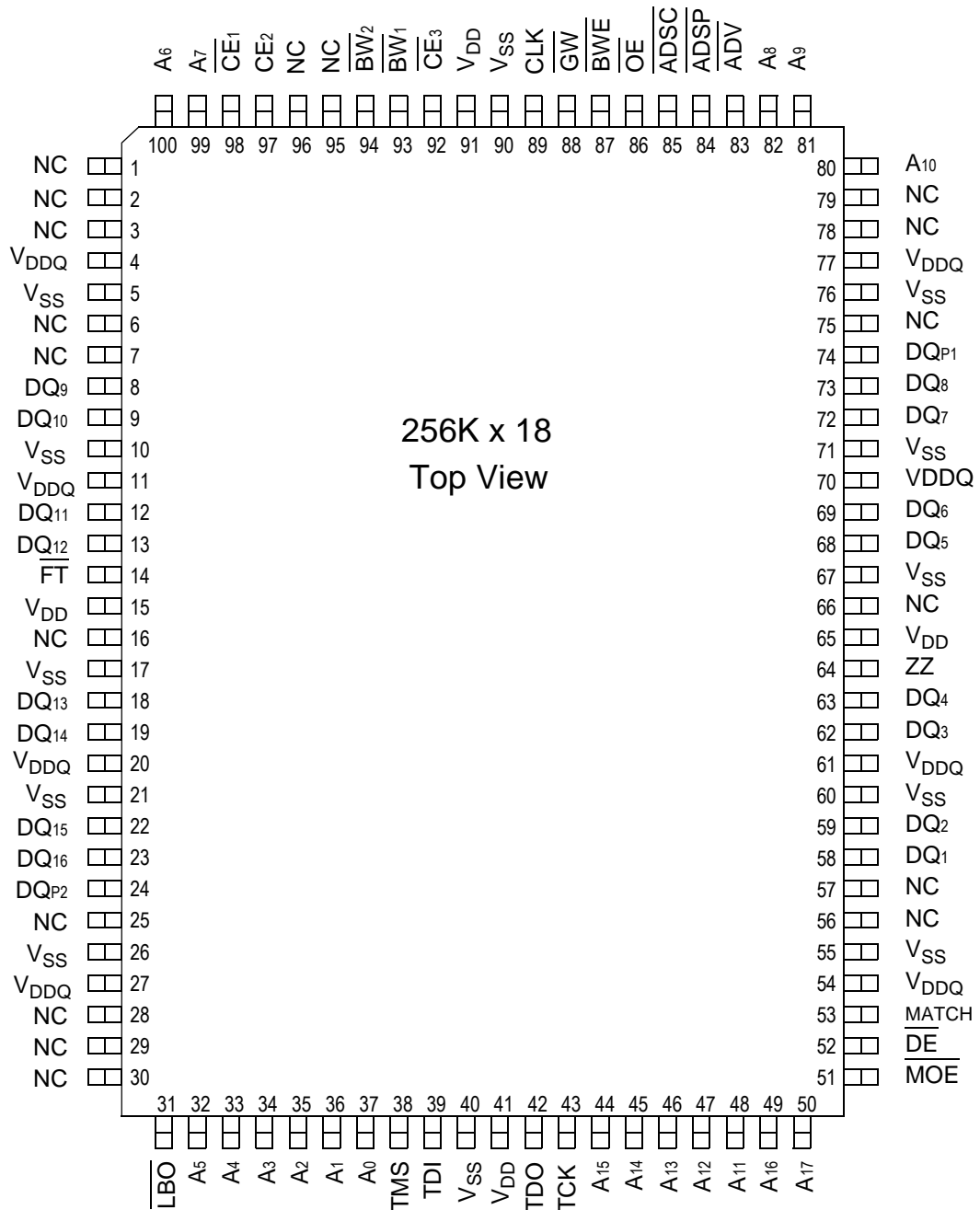

84118 PadOut
119-Bump BGA—Top View

	1	2	3	4	5	6	7
A	V _{DDQ}	A6	A7	$\overline{\text{ADSP}}$	A8	A9	V _{DDQ}
B	NC	E2	A4	$\overline{\text{ADSC}}$	A15	$\overline{\text{E}}_3$	NC
C	NC	A5	A3	V _{DD}	A14	A16	NC
D	DQB1	NC	V _{SS}	NC	V _{SS}	DQP1	NC
E	NC	DQB2	V _{SS}	$\overline{\text{E}}_1$	V _{SS}	NC	DQA8
F	V _{DDQ}	NC	V _{SS}	$\overline{\text{G}}$	V _{SS}	DQA7	V _{DDQ}
G	NC	DQB3	$\overline{\text{B}}_B$	$\overline{\text{ADV}}$	NC	NC	DQA6
H	DQB4	NC	V _{SS}	$\overline{\text{GW}}$	V _{SS}	DQA5	NC
J	V _{DDQ}	V _{DD}	NC	V _{DD}	NC	V _{DD}	V _{DDQ}
K	NC	DQB5	V _{SS}	CK	V _{SS}	NC	DQA4
L	DQB6	NC	NC	NC	$\overline{\text{B}}_A$	DQA3	NC
M	V _{DDQ}	DQB7	V _{SS}	$\overline{\text{BW}}$	V _{SS}	MATCH	V _{DDQ}
N	DQB8	NC	V _{SS}	A1	V _{SS}	DQA2	$\overline{\text{DE}}$
P	NC	DQP2	V _{SS}	A0	V _{SS}	$\overline{\text{MOE}}$	DQA1
R	NC	A2	$\overline{\text{LBO}}$	V _{DD}	$\overline{\text{FT}}$	A13	NC
T	NC	A10	A11	NC	A12	A17	ZZ
U	V _{DDQ}	TMS	TDI	NC	TDO	TCK	V _{DDQ}

TQFP Pin Description

Pin Location	Symbol	Description
37, 36, 35, 34, 33, 32, 100, 99, 82, 81, 80, 48, 47, 46, 45, 44, 49, 50	A0–A17	Address Input Signals—Inputs are registered and must meet setup and hold times, as specified on page 11 .
89	CLK	Clock Input Signal
87	$\overline{\text{BWE}}$	Byte Write Enable Signal—The byte write enable signal needs to be combined with one of the four byte write signals for a write operation to occur.
93	$\overline{\text{BW1}}$	Byte Write signal for data outputs 1 thru 8
94	$\overline{\text{BW2}}$	Byte Write signal for data outputs 9 thru 16
88	$\overline{\text{GW}}$	Global Write Enable
92, 97, 98	$\overline{\text{CE1}}, \overline{\text{CE2}}, \overline{\text{CE3}}$	Chip Enables
86	$\overline{\text{OE}}$	Output Enable
83	$\overline{\text{ADV}}$	Burst address advance
84, 85	$\overline{\text{ADSP}}, \overline{\text{ADSC}}$	Address status signals
58, 59, 62, 63, 68, 69, 72, 73, 8, 9, 12, 13, 18, 19, 22, 23	DQ1–DQ16	Data Input and Output pins
74, 24	DQP1–DQP2	Parity Input and Output pins
53	MATCH	Match Output
51	$\overline{\text{MOE}}$	Match Output Enable
52	$\overline{\text{DE}}$	Data Enable—Data input registers are updated only when $\overline{\text{DE}}$ is active.
64	ZZ	Power down control—Application of ZZ will result in a low standby power consumption.
14	$\overline{\text{FT}}$	Flow Through or Pipeline mode
31	$\overline{\text{LBO}}$	Linear Order Burst mode
38	TMS	Test Mode Select
39	TDI	Test Data In
42	TDO	Test Data Out
43	TCK	Test Clock
15, 41, 65, 91	V _{DD}	3.3 V power supply
5, 10, 17, 21, 26, 40, 55, 60, 67, 71, 76, 90	V _{SS}	Ground
4, 11, 20, 27, 54, 61, 70, 77	V _{DDQ}	2.5 V/3.3 V output power supply
1, 2, 3, 6, 7, 16, 25, 28, 29, 30, 56, 57, 66, 75, 78, 79, 95, 96	NC	No Connect

PBGA Pin Description

Pin Location	Symbol	Description
P4, N4, R2, C3, B3, C2, A2, A3, A5, A6, T6, C5, R6, T5, T2, T3, B5, C6	A0–A17	Address Input Signals—Inputs are registered and must meet setup and hold times, as specified on page 11 .
K4	CLK	Clock Input Signal
M4	$\overline{\text{BWE}}$	Byte Write Enable Signal—The byte write enable signal needs to be combined with one of the four byte write signals for a write operation to occur.
L5	$\overline{\text{BW1}}$	Byte Write signal for data outputs 1 thru 8
G3	$\overline{\text{BW2}}$	Byte Write signal for data outputs 9 thru 16
H4	$\overline{\text{GW}}$	Global Write Enable
E4, B2, B6	$\overline{\text{CE1}}, \overline{\text{CE2}}, \overline{\text{CE3}}$	Chip Enables
F4	$\overline{\text{OE}}$	Output Enable
G4	$\overline{\text{ADV}}$	Burst address advance
A4, B4	$\overline{\text{ADSP}}, \overline{\text{ADSC}}$	Address status signals
P7, N6, L6, K7, H6, G7, F6, E7, D1, E2, G2, H1, K2, L1, M2, N1	DQ1–DQ16	Data Input and Output pins
D6, P2	DQP1–DQP2	Parity Input and Output pins
M6	MATCH	Match Output
P6	$\overline{\text{MOE}}$	Match Output Enable
N7	$\overline{\text{DE}}$	Data Enable—Data input registers are updated only when $\overline{\text{DE}}$ is active.
T7	ZZ	Power down control—Application of ZZ will result in a low standby power consumption.
R5	$\overline{\text{FT}}$	Flow Through or Pipeline mode
R3	$\overline{\text{LBO}}$	Linear Order Burst mode
U2	TMS	Test Mode Select
U3	TDI	Test Data In
U5	TDO	Test Data Out
U4	TCK	Test Clock
C4, J2, J4, J6, R4	V_{DD}	3.3 V power supply
D3, D5, E3, E5, F3, F5, H3, H5, K3, K5, M3, M5, N3, N5, P3, P5	V_{SS}	Ground
A1, A7, F1, F7, J1, J7, M1, M7, U1, U7	V_{DDQ}	2.5 V/3.3 V output power supply
B1, B7, C1, C7, D2, D4, D7, E1, E6, F2, G1, G5, G6, H2, H7, J3, J5, K1, K6, L2, L3, L4, L7, N2, P1, RR1, R7, T1, T4, U6	NC	No Connect

Functional Block Diagram

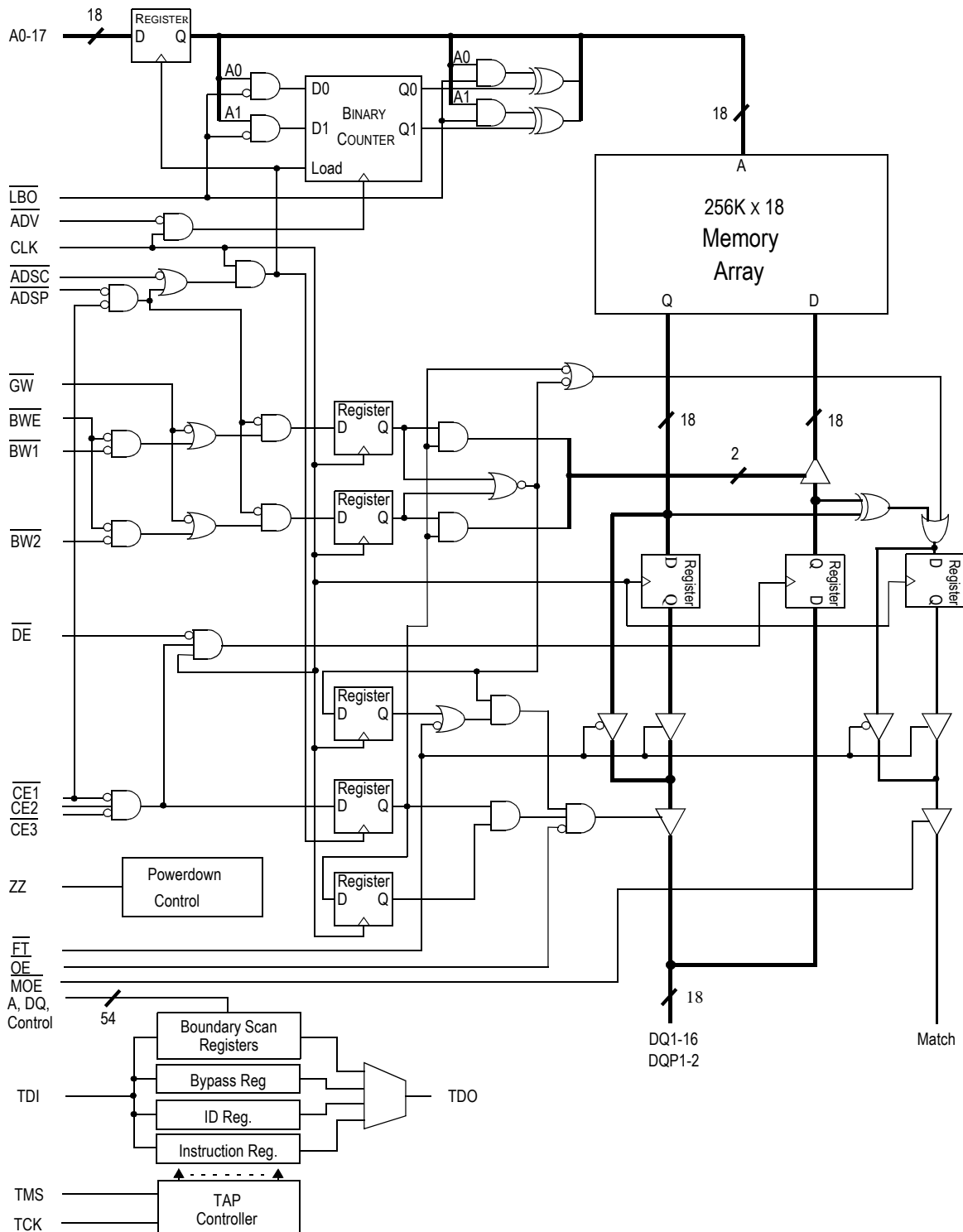

Mode Pin Function

$\overline{\text{LBO}}$	Function
L	Linear Burst
H or NC	Interleaved Burst

$\overline{\text{FT}}$	Function
L	Flow Through
H or NC	Pipeline

Power Down Control

ZZ	Function
L or NC	Active
H	Standby, $\text{IDD} = \text{ISB}$

Note:

There are pull up devices on $\overline{\text{LBO}}$ and $\overline{\text{FT}}$ pins and pull down device on ZZ pin, so those input pins can be unconnected and the chip will operate in the default states as specified in the above tables.

Linear Burst Sequence

	A[1:0]	A[1:0]	A[1:0]	A[1:0]
1st address	00	01	10	11
2nd address	01	10	11	00
3rd address	10	11	00	01
4th address	11	00	01	10

Interleaved Burst Sequence

	A[1:0]	A[1:0]	A[1:0]	A[1:0]
1st address	00	01	10	11
2nd address	01	00	11	10
3rd address	10	11	00	01
4th address	11	10	01	00

Byte Write Function

Function	$\overline{\text{GW}}$	$\overline{\text{BWE}}$	$\overline{\text{BW1}}$	$\overline{\text{BW2}}$
Read	H	H	X	X
Read	H	L	H	H
Write all bytes	L	X	X	X
Write all bytes	H	L	L	L
Write byte 1	H	L	L	H
Write byte 2	H	L	H	L

Note: H = logic high, L = logic low, NC = no connect

Synchronous Truth Table

Operation	Address Used	$\overline{CE1}$	$\overline{CE2}$	$\overline{CE3}$	\overline{ADSP}	\overline{ADSC}	\overline{ADV}	\overline{Write}	\overline{OE}	CLK	DQ
Deselect Cycle, Power Down	none	H	X	X	X	L	X	X	X	L-H	High-Z
Deselect Cycle, Power Down	none	L	L	X	L	X	X	X	X	L-H	High-Z
Deselect Cycle, Power Down	none	L	X	H	L	X	X	X	X	L-H	High-Z
Deselect Cycle, Power Down	none	L	L	X	H	L	X	X	X	L-H	High-Z
Deselect Cycle, Power Down	none	L	X	H	H	L	X	X	X	L-H	High-Z
Read Cycle, Begin Burst	external	L	H	L	L	X	X	X	L	L-H	Q
Read Cycle, Begin Burst	external	L	H	L	L	X	X	X	H	L-H	High-Z
Read Cycle, Begin Burst	external	L	H	L	H	L	X	H	L	L-H	Q
Read Cycle, Begin Burst	external	L	H	L	H	L	X	H	H	L-H	High-Z
Write Cycle, Begin Burst	external	L	H	L	H	L	X	L	X	L-H	D
Read Cycle, Continue Burst	next	X	X	X	H	H	L	H	L	L-H	Q
Read Cycle, Continue Burst	next	X	X	X	H	H	L	H	H	L-H	High-Z
Read Cycle, Continue Burst	next	H	X	X	X	H	L	H	L	L-H	Q
Read Cycle, Continue Burst	next	H	X	X	X	H	L	H	H	L-H	High-Z
Write Cycle, Continue Burst	next	X	X	X	H	H	L	L	X	L-H	D
Write Cycle, Continue Burst	next	H	X	X	X	H	L	L	X	L-H	D
Read Cycle, Suspend Burst	current	X	X	X	H	H	H	H	L	L-H	Q
Read Cycle, Suspend Burst	current	X	X	X	H	H	H	H	H	L-H	High-Z
Read Cycle, Suspend Burst	current	H	X	X	X	H	H	H	L	L-H	Q
Read Cycle, Suspend Burst	current	H	X	X	X	H	H	H	H	L-H	High-Z
Write Cycle, Suspend Burst	current	X	X	X	H	H	H	L	X	L-H	D
Write Cycle, Suspend Burst	current	H	X	X	X	H	H	L	X	L-H	D

Notes:

1. X means "don't care," H means "logic high," L means "logic low."
2. \overline{Write} is the logic function of \overline{GW} , \overline{BWE} , $\overline{BW1}$, $\overline{BW2}$. See Byte Write Function table for detail.
3. All inputs, except \overline{OE} , must meet setup and hold on rising edge of CLK.
4. Suspending burst generates a wait cycle.
5. \overline{ADSP} LOW along with SRAM being selected always initiates a Read cycle at the L-H edge of the clock (CLK).
6. A Write cycle can only be performed by setting \overline{Write} low for the clock L-H edge of the subsequent wait cycle.
Refer to **page 12** for the Write timing diagram.

Truth Table For Read/Write/Compare/Fill Write Operation

	$\overline{\text{CE}}$	$\overline{\text{Write}}$	$\overline{\text{DE}}$	$\overline{\text{MOE}}$	$\overline{\text{OE}}$	Match	DQ
Read	L	H	X	X	L	—	Q
Write	L	L	L	X	H	—	D
Compare	L	H	L	L	H	Data Out	D
Fill Write	L	L	H	X	X	—	X
Match Deselect	H	X	X	L	X	High	High Z
Deselect	H	X	X	H	X	High Z	High Z

Notes:

1. X means "don't care," H means "logic high," L means "logic low."
2. $\overline{\text{Write}}$ is the logic function of $\overline{\text{GW}}$, $\overline{\text{BWE}}$, $\overline{\text{BW1}}$, $\overline{\text{BW2}}$. See Byte Write Function table for detail.
3. $\overline{\text{CE}}$ is defined as $\overline{\text{CE1}}=\text{L}$, $\overline{\text{CE2}}=\text{H}$ and $\overline{\text{CE3}}=\text{L}$
4. All signals are synchronous and are sampled by CLK except $\overline{\text{OE}}$ and $\overline{\text{MOE}}$. $\overline{\text{OE}}$ and $\overline{\text{MOE}}$ are asynchronous and drive the bus immediately.

Absolute Maximum Ratings (Voltage reference to $V_{SS} = 0 \text{ V}$)

Symbol	Description	Commerical	Unit
V_{DD}	Supply Voltage	-0.5 to 4.6	V
V_{DDQ}	Output Supply Voltage	-0.5 to V_{DD}	V
V_{CLK}	CLK Input Voltage	-0.5 to 6	V
V_{in}	Input Voltage	-0.5 to $V_{DD} + 0.5$ ($\leq 4.6 \text{ V max.}$)	V
V_{out}	Output Voltage	-0.5 to $V_{DD} + 0.5$ ($\leq 4.6 \text{ V max.}$)	V
I_{out}	Output Current per I/O	+/-20	mA
P_D	Power Dissipation	1.5	W
T_{OPR}	Operating Temperature	0 to 70	°C
T_{STG}	Storage Temperature	-55 to 125	°C

Note: Permanent damage to the device may occur if the Absolute Maximun Ratings are exceeded. Functional operation should be restricted to the recommended operation conditions. Exposure to higher than recommended voltages, for an extended period of time, could effect the performance and reliability of this component.

Package Thermal Characteristics

Rating	Layer Board	Symbol	TQFP max	PBGA max	Unit	Notes
Junction to Ambient (at 200 lfm)	single	$R_{\theta JA}$	32	28	°C/W	1,2
Junction to Ambient (at 200 lfm)	four	$R_{\theta JA}$	20	18	°C/W	1,2
Junction to Case (TOP)	—	$R_{\theta JC}$	7	4	°C/W	3

Notes:

- Junction temperature is a function of SRAM power dissipation, package thermal resistance, mounting board temperature, ambient. Temperature air flow, board density, and PCB thermal resistance.
- SCMI G-38-87.
- Average thermal resistance between die and top surface, MIL SPEC-883, Method 1012.1.

AC Test Conditions
 $(V_{DD} = 3.135\text{ V} - 3.6\text{ V}, T_A = 0 - 70^\circ\text{C})$

Parameter	Conditions
Input high level	$V_{IH} = 2.3\text{ V}$
Input low level	$V_{IL} = 0.2\text{ V}$
Input slew rate	$TR = 1\text{ V/ns}$
Input reference level	1.25 V
Output reference level	1.25 V
Output load	Fig. 1 & 2

Notes:

- Include scope and jig capacitance.
- Test conditions as specified with output loading as shown in **Fig. 1** unless otherwise noted.
- Output load 2 for t_{LZ} , t_{HZ} , t_{OLZ} and t_{OHZ} .
- Device is deselected as defined by the Truth Table.

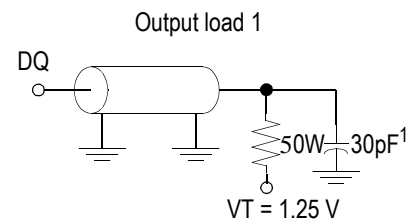

FIG. 1

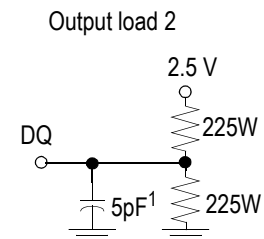

FIG. 2

DC Characteristics and Supply Currents (Voltage reference to $V_{SS} = 0\text{ V}$)

 ($V_{DD} = 3.135\text{ V} - 3.6\text{ V}$, $T_a = 0 - 70^\circ\text{C}$ for Commercial Temperature Offering)

Parameter	Symbol	Test Conditions	Min	Max
Input Leakage Current (except ZZ, FT, LBO pins)	I_{IL}	$V_{IN} = 0$ to V_{DD}	-1 μA	1 μA
ZZ Input Current	I_{inZZ}	$V_{DD} \geq V_{IN} \geq V_{IH}$ $0\text{ V} \leq V_{IN} \leq V_{IH}$	-1 μA -1 μA	1 μA 300 μA
Mode Input Current (FT & LBO pins)	I_{inM}	$V_{DD} \geq V_{IN} \geq V_{IL}$ $0\text{ V} \leq V_{IN} \leq V_{IL}$	-30 $0\mu\text{A}$ -1 μA	1 μA 1 μA
Output Leakage Current	I_{ol}	Output Disable, $V_{OUT} = 0$ to V_{DD}	-1 μA	1 μA
Output High Voltage	V_{OH}	$I_{OH} = -4\text{ mA}$, $V_{DDQ} = 2.375\text{ V}$	1.7 V	
Output High Voltage	V_{OH}	$I_{OH} = -4\text{ mA}$, $V_{DDQ} = 3.135\text{ V}$	2.4 V	
Output Low Voltage	V_{OL}	$I_{OL} = +4\text{ mA}$		0.4 V

Operating Currents

Parameter	Test Conditions	Symbol	-166		-150		-133		-100		Unit
			0 to 70°C	-40 to +85°C	0 to 70°C	-40 to +85°C	0 to 70°C	-40 to +85°C	0 to 70°C	-40 to +85°C	
Operating Current	Device Selected; All other inputs $\geq V_{IH}$ or $\leq V_{IL}$ Output open	I_{DD} Pipeline	310	320	275	285	250	260	190	200	mA
		I_{DD} Flow Through	190	200	190	200	140	150	140	150	mA
Standby Current	$ZZ \geq V_{DD} - 0.2 V$	I_{SB} Pipeline	30	40	30	40	30	40	30	40	mA
		I_{SB} Flow Through	30	40	30	40	30	40	30	40	mA
Deselect Supply Current	Device Deselected; All other inputs $\geq V_{IH}$ OR $\leq V_{IL}$	I_{DD} Pipeline	110	120	105	115	100	110	80	90	mA
		I_{DD} Flow Through	80	90	80	90	65	75	65	75	mA

AC Electrical Characteristics

	Parameter	Symbol	-166		-150		-133		-100		Unit
			Min	Max	Min	Max	Min	Max	Min	Max	
Pipeline	Clock Cycle Time	tKC	6.0	—	6.7	—	7.5	—	10	—	ns
	Clock to Output Valid	tKQ	—	3.5	—	3.8	—	4	—	4.5	ns
	Clock to Output Invalid	tKQX	1.5	—	1.5	—	1.5	—	1.5	—	ns
	Clock to Output in Low-Z	tLZ ¹	1.5	—	1.5	—	1.5	—	1.5	—	ns
	Clock to Match Valid	tKM	—	3.5	—	3.8	—	4	—	4.5	ns
	Clock to Match Invalid	tKMX	1.5	—	1.5	—	1.5	—	1.5	—	ns
	Clock to Match in Low-Z	tMLZ ¹	1.5	—	1.5	—	1.5	—	1.5	—	ns
Flow-Thru	Clock Cycle Time	tKC	10.0	—	10.0	—	15.0	—	15.0	—	ns
	Clock to Output Valid	tKQ	—	8.5	—	10.0	—	11.0	—	12.0	ns
	Clock to Output Invalid	tKQX	3.0	—	3.0	—	3.0	—	3.0	—	ns
	Clock to Output in Low-Z	tLZ ¹	3.0	—	3.0	—	3.0	—	3.0	—	ns
	Clock to Match Valid	tKM	—	8.5	—	10.0	—	11.0	—	12.0	ns
	Clock to Match Invalid	tKMX	3.0	—	3.0	—	3.0	—	3.0	—	ns
	Clock to Match in Low-Z	tMLZ ¹	3.0	—	3.0	—	3.0	—	3.0	—	ns
	Clock HIGH Time	tKH	1.3	—	1.5	—	1.7	—	2	—	ns
	Clock LOW Time	tKL	1.5	—	1.7	—	1.9	—	2.2	—	ns
	Clock to Output in High-Z	tHZ ¹	1.5	3.5	1.5	3.8	1.5	4	1.5	5	ns
	$\overline{\text{OE}}$ to Output Valid	tOE	—	3.5	—	3.8	—	4	—	5	ns
	$\overline{\text{OE}}$ to output in Low-Z	tOLZ ¹	0	—	0	—	0	—	0	—	ns
	$\overline{\text{OE}}$ to output in High-Z	tOHZ ¹	—	3.5	—	3.8	—	4	—	5	ns
	$\overline{\text{MOE}}$ to Match Valid	tMOE	—	3.5	—	3.8	—	4	—	5	ns
	$\overline{\text{MOE}}$ to Match in Low-Z	tMOLZ ¹	0	—	0	—	0	—	0	—	ns
	$\overline{\text{MOE}}$ to Match in High-Z	tMOHZ ¹	—	3.5	—	3.8	—	4	—	5	ns

AC Electrical Characteristics

Parameter	Symbol	-166		-150		-133		-100		Unit
		Min	Max	Min	Max	Min	Max	Min	Max	
Setup time	tS	1.5	—	1.5	—	2.0	—	2.0	—	ns
Hold time	tH	0.5	—	0.5	—	0.5	—	0.5	—	ns
ZZ setup time	tZZS ²	5	—	5	—	5	—	5	—	ns
ZZ hold time	tZZH ²	1	—	1	—	1	—	1	—	ns
ZZ recovery	tZZR	20	—	20	—	20	—	20	—	ns

Notes:

1. These parameters are sampled and are not 100% tested
2. ZZ is an asynchronous signal. However, in order to be recognized on any given clock cycle, ZZ must meet the specified setup and hold times as specified above.

Write Cycle Timing

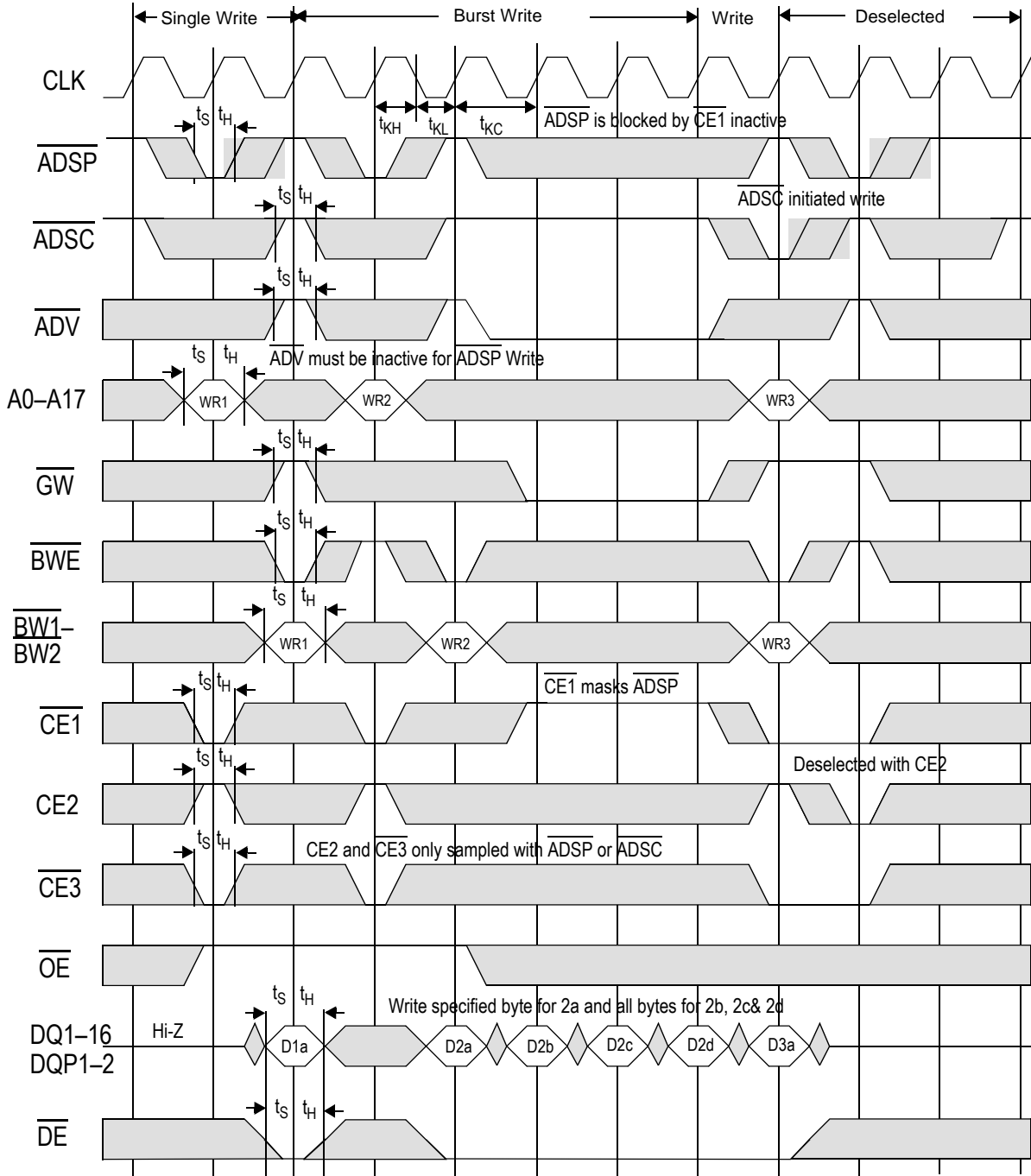

Flow Through—Read Cycle Timing

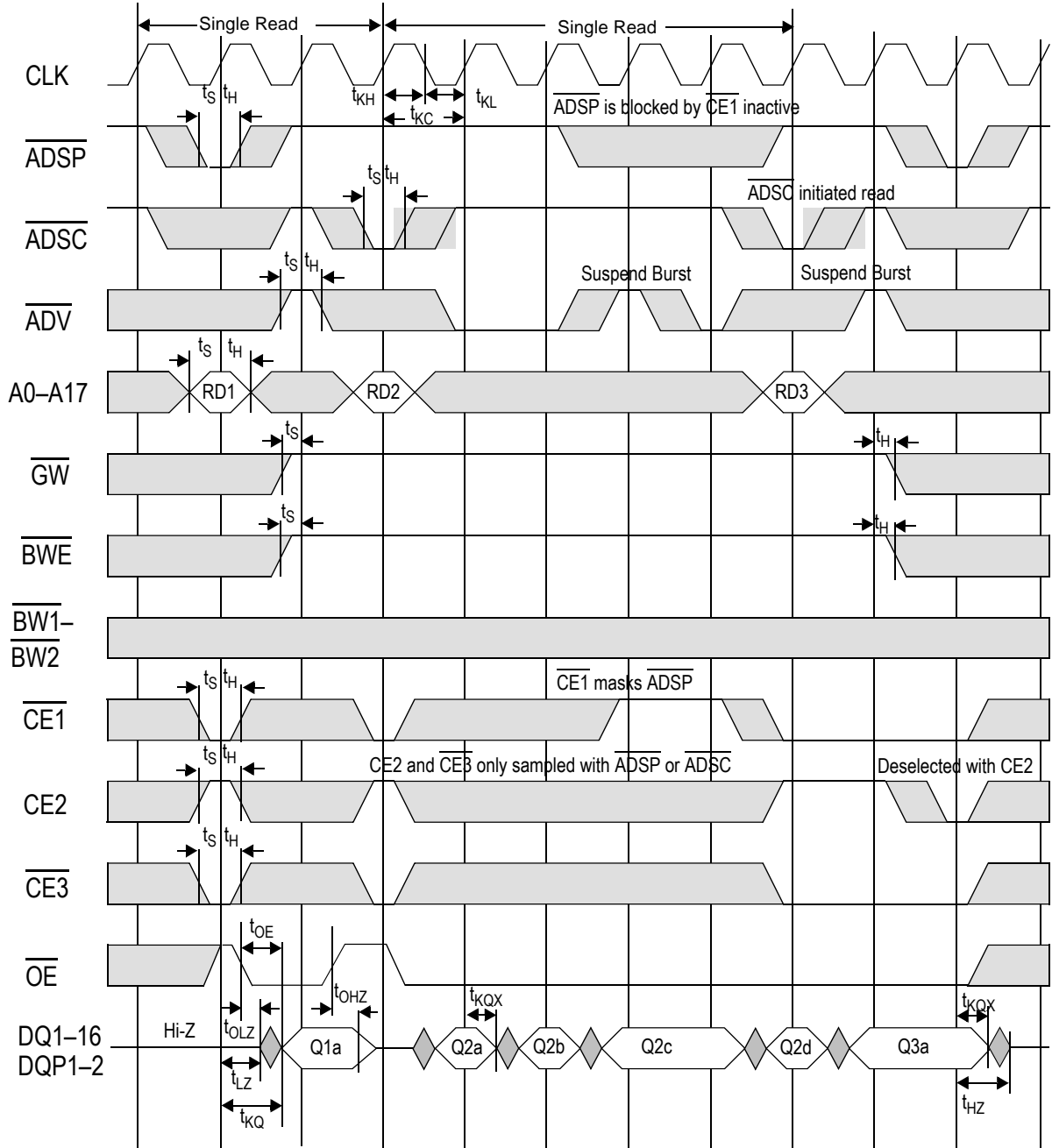

Flow Through—Read/Write Cycle Timing

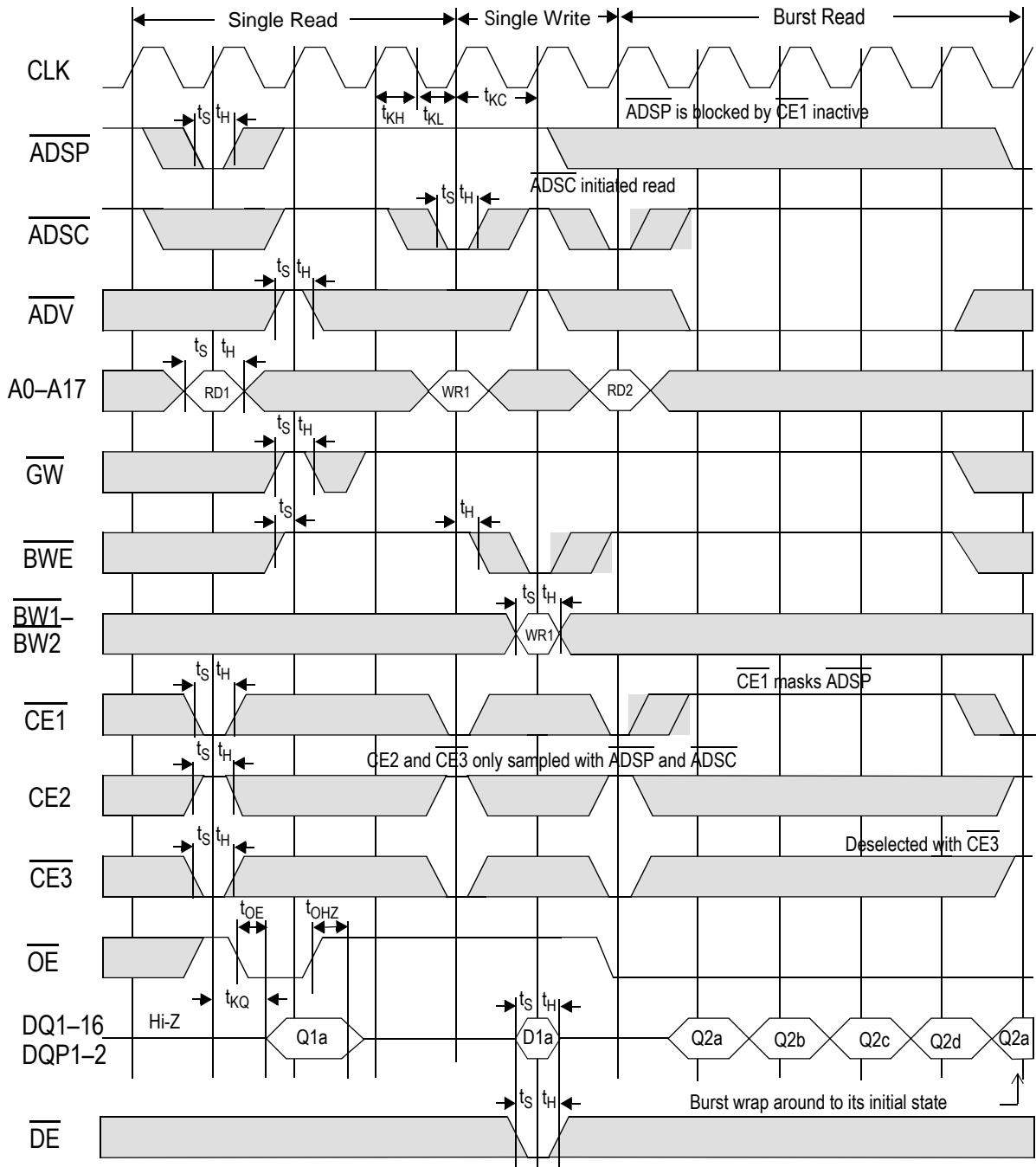

Pipeline—Read Cycle Timing

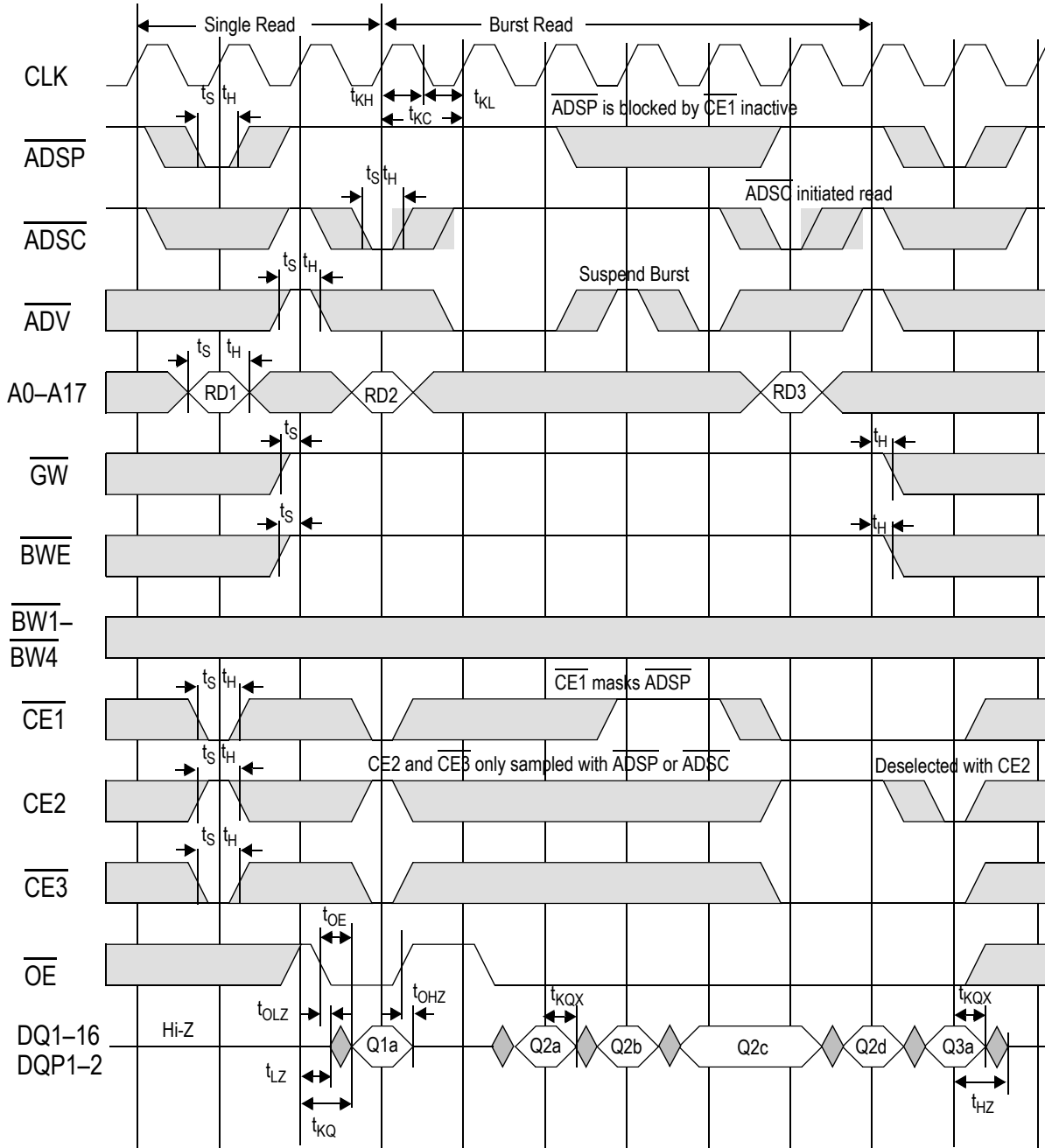

Pipeline—Read/Write Cycle Timing

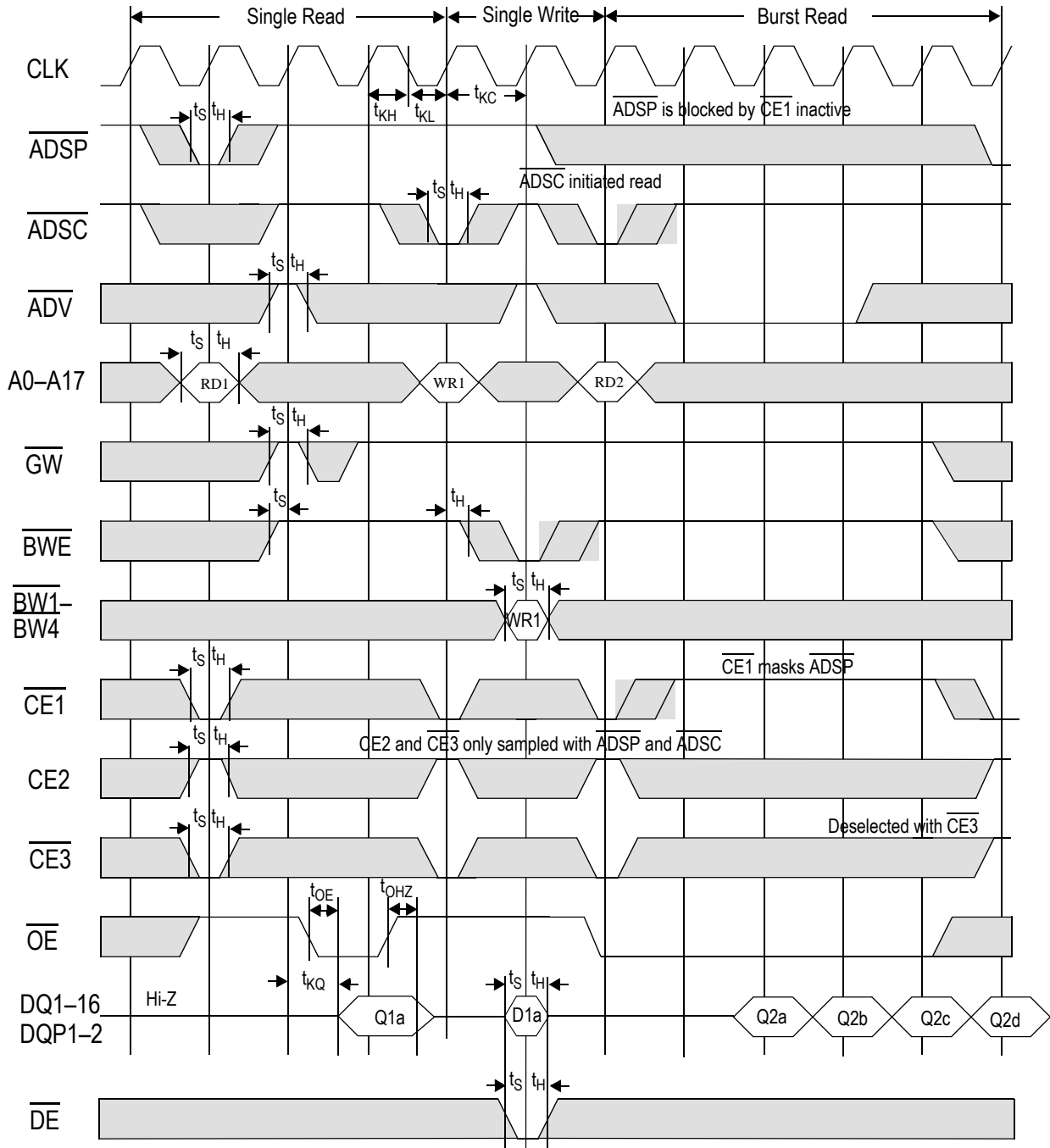

Flow Through—Compare/Fill Write Cycle Timing

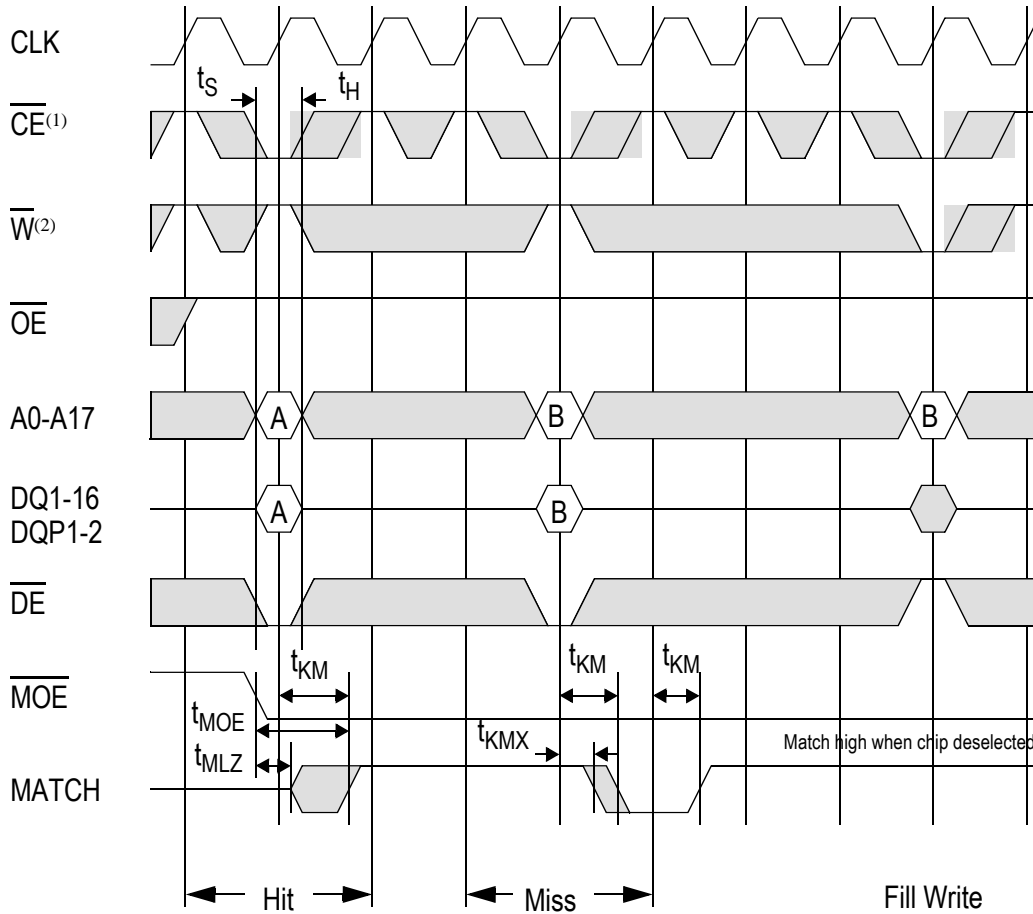

Notes:

1. $\overline{CE} = L$ is defined as $\overline{CE1}=L$, $CE2=H$ and $\overline{CE3}=L$
2. $\overline{W} = L$ is the Assertive function of \overline{GW} , \overline{BWE} , $\overline{BW1}$, $\overline{BW2}$. See Byte Write Function table for detail.

Pipeline—Compare/Fill Write Cycle Timing

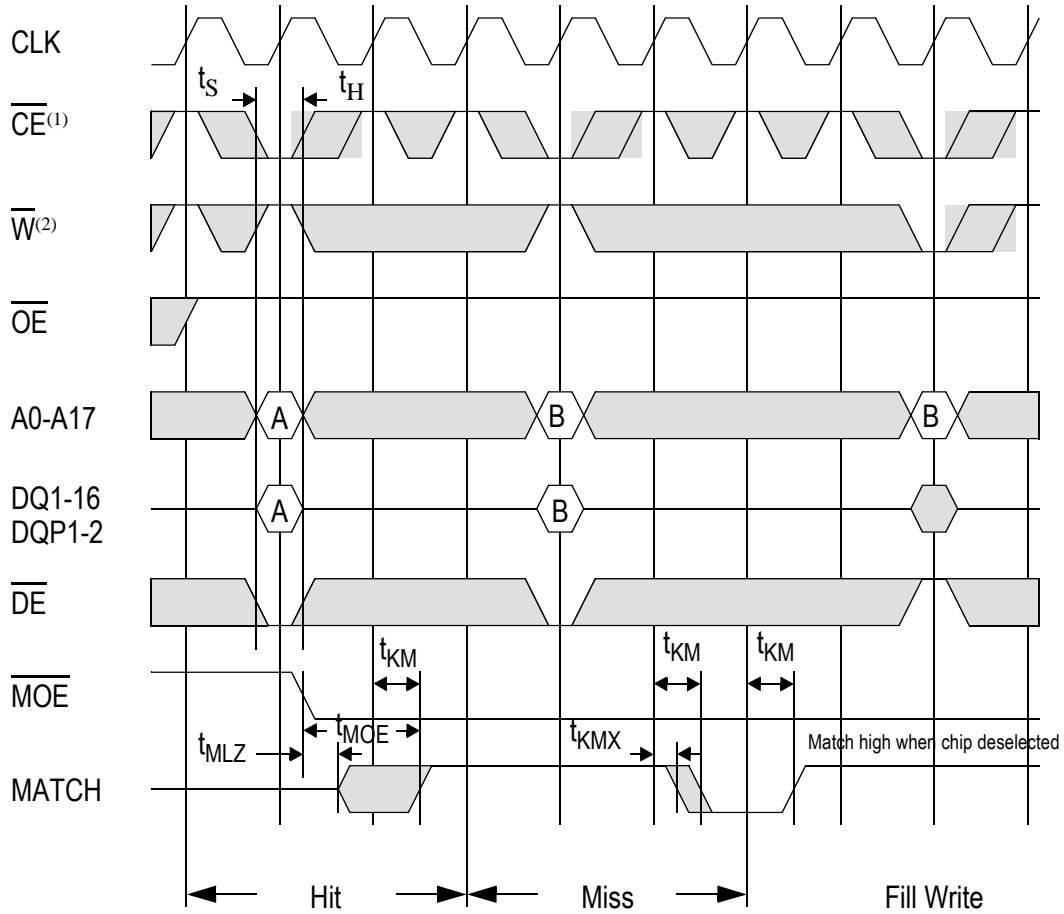

Notes:

1. $\overline{CE} = L$ is defined as $CE1=L$, $CE2=H$ and $CE3=L$
2. $\overline{W} = L$ is the Asertive function of \overline{GW} , \overline{BWE} , $\overline{BW1}$, $\overline{BW2}$. See Byte Write Function table for detail.

ZZ Timing

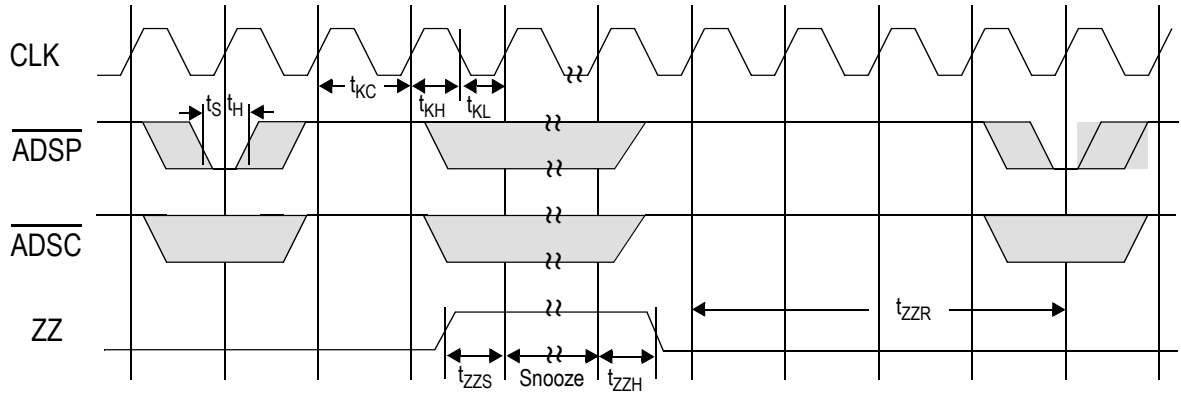

Test Mode Description

Functional Description

The GS84118 provides JTAG boundary scan interface using IEEE standard 1149.1 protocol. The Test mode is intended to provide a mechanism for testing the interconnect between master (processor, controller, etc.), SRAM, other components and the Printed Circuit Board.

Test Access Port (TAP)

Four pins (as defined in Pin Description Tables) are used to performed JTAG functions. TDI input is used to scan test data serially into one of three registers (Instruction Register, Boundary Scan Register and Bypass Register). TDO is the output pin to serially output scan test data. The TDI sends the data into the LSB of the selected register and the MSB of that register feeds the data to TDO. TMS input pin controls the state transition of 16 state TAP controllers, as specified in IEEE standard 1149.1. Inputs on TDI and TMS are registered on the rising edge of TCK clock, and the output data on TDO is presented on the falling edge of TCK. The TDO driver is in active state only when TAP controller is in Shift-IR state or in Shift -DR state.

TAP Controller

Sixteen state controllers are implemented as specified in IEEE standard 1149.1.

The controller enters the Reset state either through

- Power up or
- Apply logic 1 on TMS input pin on 5 consecutive rising edges.

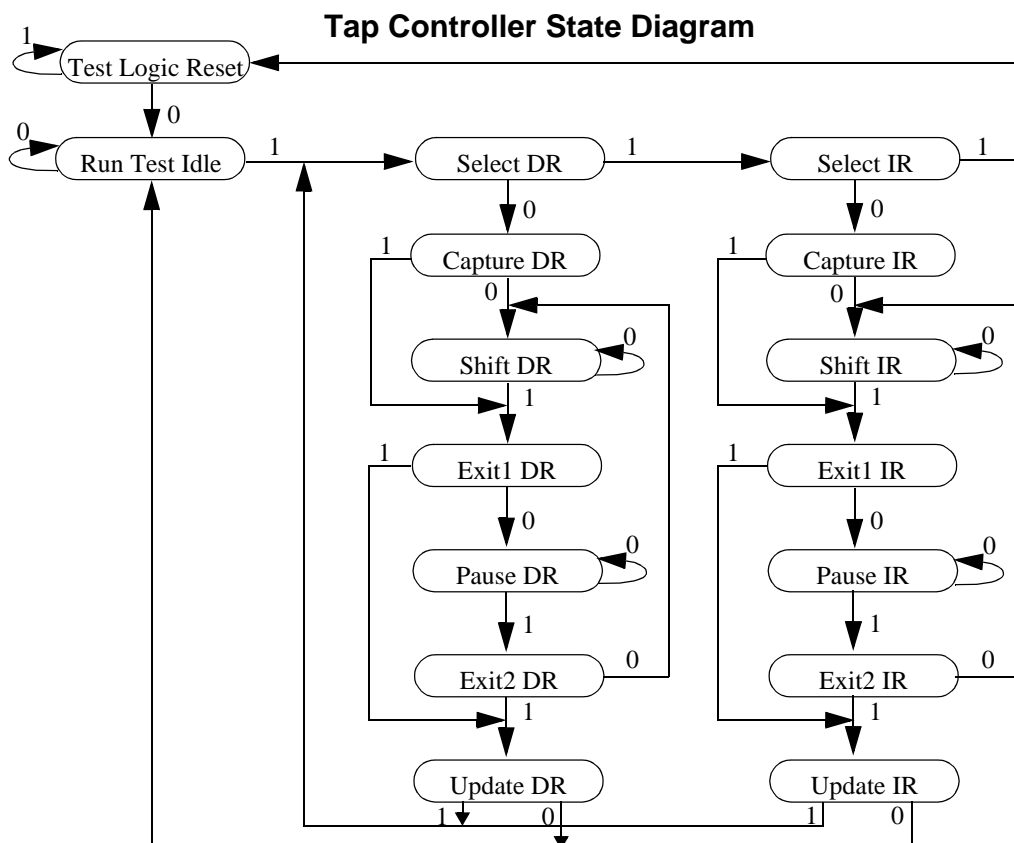

Instruction Register (3 Bits)

The JTAG Instruction register is consisted of shift register stage and parallel output latch. The register is 3 bits wide and is encoded as follow:

Octal	MSB	—	LSB	Instruction
0	0	0	0	Bypass
1	0	0	1	IDCODE—Read device ID
2	0	1	0	Sample-Z—Sample Inputs and tri-state DQs, Match
3	0	1	1	Bypass
4	1	0	0	Sample—Sample Inputs
5	1	0	1	Private—Manufacturer use only
6	1	1	0	Bypass
7	1	1	1	Bypass

Bypass Register (1 Bit)

The Bypass Register is one bit wide and is connected electrically between TDI and TDO and provides the minimum length serially path between TDI and TDO.

ID Register (32 Bits)

The ID Register are 32 bits wide and are listed as follow:

Header	ID[0]	1
GSI ID (89 decimal in bank 2)	ID[7:1]	101 1001
	ID[11:8]	0001
Part Number	ID[27:12]	0000 0000 0000 0000
Revision Number	ID[31:28]	xxxx

Boundary Scan Register (54 Bits)

The Boundary Scan Register are 54 bits wide and are listed as follow:

DQx, Match	19
Address	18
\overline{GW} , \overline{BWE} , $\overline{BW1-2}$, \overline{DE}	5
$\overline{CE1}$, $\overline{CE2}$, $\overline{CE3}$	3
\overline{OE} , \overline{MOE}	2
\overline{ADSP} , \overline{ADSC} , \overline{ADV}	3
\overline{ZZ} , \overline{FT} , \overline{LBO}	3
CLK	1
Total	54

Scan Order (Order by exit sequence)

Order	Signal	TQFP	BGA
1	A15	44	3T
2	A14	45	2T
3	A13	46	5T
4	A12	47	6R
5	A11	48	5C
6	A16	49	5B
7	$\overline{A17}$	50	6C
8	\overline{MOE}	51	6P
9	\overline{DE}	52	7N
10	MATCH	53	6M
11	DQ1	58	7P
12	DQ2	59	6N
13	DQ3	62	6L
14	DQ4	63	7K
15	\overline{ZZ}	64	7T
16	DQ5	68	6H
17	DQ6	69	7G
18	DQ7	72	6F
19	DQ8	73	7E
20	DQP1	74	6D
21	A10	80	6T
22	A9	81	6A
23	$\overline{A8}$	82	5A
24	\overline{ADV}	83	4G
25	\overline{ADSP}	84	4A
26	\overline{ADSC}	85	4B
27	\overline{OE}	86	4F

Order	Signal	TQFP	BGA
28	\overline{BWE}	87	4M
29	\overline{GW}	88	4H
30	CLK	89	4K
31	$\overline{CE3}$	92	6B
32	$\overline{BW1}$	93	5L
33	$\overline{BW2}$	94	3G
34	$\overline{CE2}$	97	2B
35	$\overline{CE1}$	98	4E
36	A7	99	3A
37	A6	100	2A
38	DQ9	8	1D
39	DQ10	9	2E
40	DQ11	12	2G
41	DQ12	13	1H
42	\overline{FT}	14	5R
43	DQ13	18	2K
44	DQ14	19	1L
45	DQ15	22	2M
46	DQ16	23	1N
47	$\overline{DQP2}$	24	2P
48	\overline{LBO}	31	3R
49	A5	32	2C
50	A4	33	3B
51	A3	34	3C
52	A2	35	2R
53	A1	36	4N
54	A0	37	4P

Test Mode AC Electrical Characteristics

Parameter	Symbol	Min	Max	Unit
TCK Cycle Time	tTKC	20	—	ns
TCK Low to TDO Valid	tTKQ	—	10	ns
TCK High Pulse Width	tTKH	10	—	ns
TCK Low Pulse Width	tTKL	10	—	ns
TDI & TMS Set Up Time	tTS	5	—	ns
TDI & TMS Hold Time	tTH	5	—	ns

Test Mode Timing Diagram

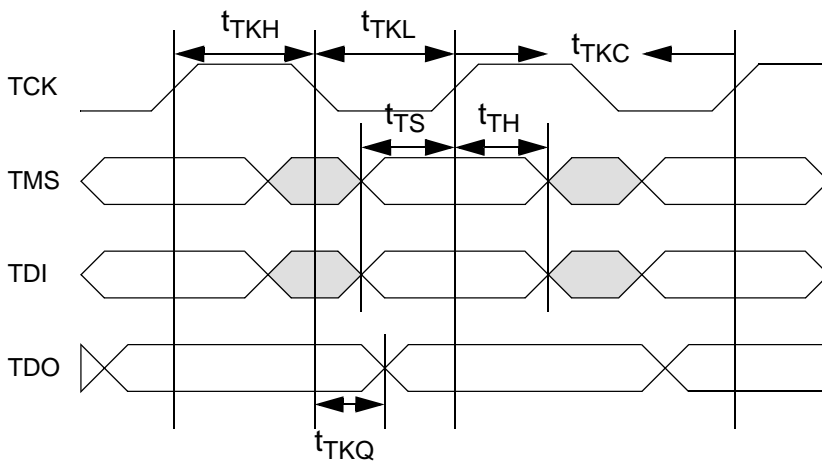

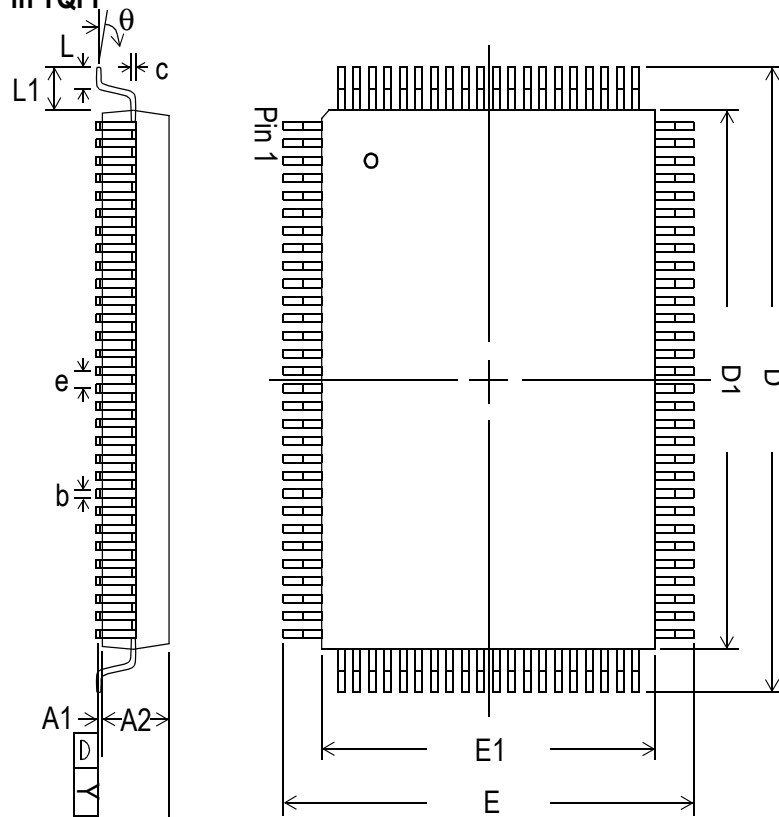
Package Dimensions—100-Pin TQFP

Symbol	Description	Min.	Nom.	Max
A1	Standoff	0.05	0.10	0.15
A2	Body Thickness	1.35	1.40	1.45
B	Lead Width	0.20	0.30	0.40
C	Lead Thickness	0.09		0.20
D	Terminal Dimension	21.9	22.0	22.1
D1	Package Body	19.9	20.0	20.1
E	Terminal Dimension	15.9	16.0	16.1
E1	Package Body	13.9	14.0	14.1
E	Lead Pitch		0.65	
L	Foot Length	0.45	0.60	0.75
L1	Lead Length		1.00	
Y	Coplanarity			0.10
Q	Lead Angle	0°		7°

Notes:

1. All dimensions are in millimeters (mm).
2. Package width and length do not include mold protrusion.

Package Dimesions - 119 Pin PBGA

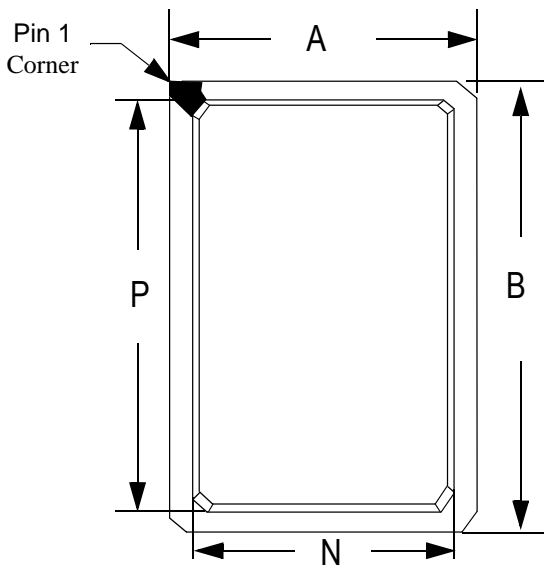

Top View

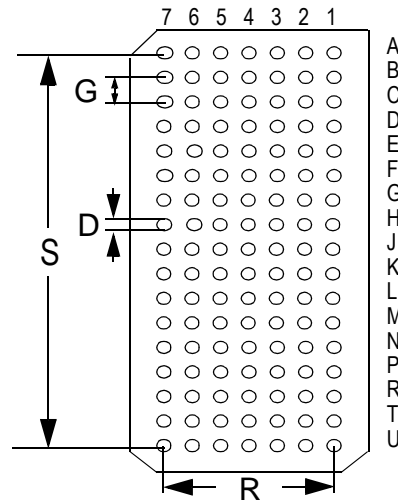

Bottom View

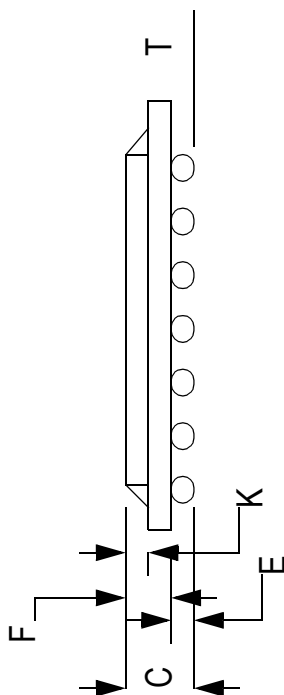

Side View

Package Dimesions - 119 Pin PBGA

Symbol	Description	Min	Nom	Max
A	Width	13.8	14.0	14.2
B	Length	21.8	22.0	22.2
C	Package Height (including ball)	-		2.40
D	Ball Size	0.60	0.75	0.90
E	Ball Height	0.50	0.60	0.70
F	Package Height (excluding balls)		1.46	1.70
G	Width between Balls		1.27	
K	Package Height above board	0.80	0.90	1.00
N	Cut-out Package Width		12.00	
P	Foot Length		19.50	
R	Width of package between balls		7.62	
S	Length of package between balls		20.32	
T	Variance of Ball Height		0.15	

Unit: mm

Ordering Information

Org	Part Number ¹	Type	Package	Speed ² (MHz/ns)	T _A 3	Status
256K x 18	GS84118T-166	Pipeline/Flow Through	TQFP	166/8.5	C	
256K x 18	GS84118T-150	Pipeline/Flow Through	TQFP	150/10	C	
256K x 18	GS84118T-133	Pipeline/Flow Through	TQFP	133/11	C	
256K x 18	GS84118T-100	Pipeline/Flow Through	TQFP	100/12	C	
256K x 18	GS84118T-166I	Pipeline/Flow Through	TQFP	166/8.5	I	
256K x 18	GS84118T-150I	Pipeline/Flow Through	TQFP	150/10	I	
256K x 18	GS84118T-133I	Pipeline/Flow Through	TQFP	133/11	C	
256K x 18	GS84118T-100I	Pipeline/Flow Through	TQFP	100/12	I	
256K x 18	GS84118B-166	Pipeline/Flow Through	BGA	166/8.5	C	
256K x 18	GS84118B-150	Pipeline/Flow Through	BGA	150/10	C	
256K x 18	GS84118B-133	Pipeline/Flow Through	BGA	133/11	C	
256K x 18	GS84118B-100	Pipeline/Flow Through	BGA	100/12	C	
256K x 18	GS84118B-166I	Pipeline/Flow Through	BGA	166/8.5	I	
256K x 18	GS84118B-150I	Pipeline/Flow Through	BGA	150/10	I	
256K x 18	GS84118I-133I	Pipeline/Flow Through	BGA	133/11	C	
256K x 18	GS84118B-100I	Pipeline/Flow Through	BGA	100/12	I	

Notes:

1. Customers requiring delivery in Tape and Reel should add the character "T" to the end of the part number. Example: GS84032T-7.5T.
2. The speed column indicates the cycle frequency (Mhz) of the device in Pipelined mode and the latency (ns) in Flow Through mode. Each device is Pipeline / Flow through mode selectable by the user.
3. T_A = C = Commercial Temperature Range. T_A = I = Industrial Temperature Range.
4. GSI offers other versions this type of device in many different configurations and with a variety of different features, only some of which are covered in this data sheet. See the GSI Technology web site for a complete listing of current offerings.

4Mb Synchronous Tag RAM Datasheet Revision History

Rev. Code: Old;New	Types of Changes Format or Content	Page /Revisions;Reason
GS84118-2000207; 84118_r1_01	Content	<ul style="list-style-type: none"> • Updated BGA Pin Description to meet JEDEC standard
84118_r1_02; 84118_r1_03	Content/Format	<ul style="list-style-type: none"> • Updated format to comply with Technical Publications standards • Corrected typo in TQFP Package Description table on page 27
84118_r1_03; 84118_r1_04	Content	<ul style="list-style-type: none"> • Updated Pinout on page 3 • Updated Pin Description tables for TQFP and PBGA • Added overbar to all references of \overline{BWE}, $\overline{BW1}$, $\overline{BW2}$, \overline{GW}, $\overline{CE1}$, $\overline{CE3}$, \overline{OE}, \overline{ADV}, \overline{ADSP}, \overline{ADSC}, \overline{MOE}, \overline{DE}, \overline{FT}, and \overline{LBO} • Removed V_{DD} note from AC Electrical Characteristics table • Imported up-to-date Package Drawing for 119 PBGA
84118_r1_04; 84118_r1_05	Content	<ul style="list-style-type: none"> • Reordered pin location listings in pin description tables on pages 4 and 5 • Removed Global Write reference from \overline{BWE} description in pin description tables • Removed \overline{BWE} reference from \overline{GW} description in pin description tables • Placed overbars on Write references in Synchronous Truth Table