

100-Pin TQFP  
Commercial Temp  
Industrial Temp

**512K x 18, 256K x 36 ByteSafe™**  
**8Mb Sync Burst SRAMs**

100 MHz–66 MHz  
3.3 V V<sub>DD</sub>  
3.3 V and 2.5 V I/O

### 1.11 9/2000 Features

- $\overline{FT}$  pin for user-configurable flow through or pipelined operation
- Single Cycle Deselect (SCD) Operation
- IEEE 1149.1 JTAG-compatible Boundary Scan
- On-chip write parity checking; even or odd selectable
- 3.3 V +10%/–5% core power supply
- 2.5 V or 3.3 V I/O supply
- $\overline{LBO}$  pin for Linear or Interleaved Burst mode
- Internal input resistors on mode pins allow floating mode pins
- Default to Interleaved Pipeline mode
- Byte Write ( $\overline{BW}$ ) and/or Global Write ( $\overline{GW}$ ) operation
- Common data inputs and data outputs
- Clock Control, registered, address, data, and control
- Internal self-timed write cycle
- Automatic power-down for portable applications
- 100-lead TQFP package

		-11	-11.5	-100	-80	-66
Pipeline	tCycle	10 ns	10 ns	10 ns	12.5 ns	15 ns
3-1-1-1	t <sub>KQ</sub>	4.0 ns	4.0 ns	4.0 ns	4.5 ns	5.0 ns
	I <sub>DD</sub>	225 mA	225 mA	225 mA	200 mA	185 mA
Flow Through	t <sub>KQ</sub>	11 ns	11.5 ns	12 ns	14 ns	18 ns
	tCycle	15 ns	15 ns	15 ns	15 ns	20 ns
2-1-1-1	I <sub>DD</sub>	180 mA	180 mA	180 mA	175 mA	165 mA

## Functional Description

### Applications

The GS88118//36T is a 9,437,184-bit high performance synchronous SRAM with a 2-bit burst address counter. Although of a type originally developed for Level 2 Cache applications supporting high performance CPUs, the device now finds application in synchronous SRAM applications, ranging from DSP main store to networking chip set support.

### Controls

Addresses, data I/Os, chip enables ( $\overline{E1}$ , E2), address burst control inputs (ADSP, ADSC, ADV) and write control inputs (Bx, BW, GW) are synchronous and are controlled by a positive-edge-triggered clock input (CK). Output enable ( $\overline{G}$ ) and power down control (ZZ) are asynchronous inputs. Burst cycles can be initiated with either ADSP or ADSC inputs. In Burst mode, subsequent burst addresses are generated internally and are controlled by ADV. The burst address

counter may be configured to count in either linear or interleave order with the Linear Burst Order ( $\overline{LBO}$ ) input. The Burst function need not be used. New addresses can be loaded on every cycle with no degradation of chip performance.

### Flow Through/Pipeline Reads

The function of the Data Output register can be controlled by the user via the  $\overline{FT}$  mode pin (Pin 14). Holding the  $\overline{FT}$  mode pin low places the RAM in Flow Through mode, causing output data to bypass the Data Output Register. Holding  $\overline{FT}$  high places the RAM in Pipeline mode, activating the rising-edge-triggered Data Output Register.

### SCD Pipelined Reads

The GS88118//36T is a SCD (Single Cycle Deselect) pipelined synchronous SRAM. DCD (Dual Cycle Deselect) versions are also available. SCD SRAMs pipeline deselect commands one stage less than read commands. SCD RAMs begin turning off their outputs immediately after the deselect command has been captured in the input registers.

### Byte Write and Global Write

Byte write operation is performed by using Byte Write enable ( $\overline{BW}$ ) input combined with one or more individual byte write signals (Bx). In addition, Global Write ( $\overline{GW}$ ) is available for writing all bytes at one time, regardless of the byte write control inputs.

### ByteSafe™ Parity Functions

The GS88118//36T features ByteSafe data security functions. See detailed discussion following.

### Sleep Mode

Low power (Sleep mode) is attained through the assertion (high) of the ZZ signal, or by stopping the clock (CK). Memory data is retained during Sleep mode.

### Core and Interface Voltages

The GS88118//36T operates on a 3.3 V power supply, and all inputs/outputs are 3.3 V- and 2.5 V-compatible. Separate output power (V<sub>DDQ</sub>) pins are used to decouple output noise from the internal circuit.

GS88118 100-Pin TQFP Pinout

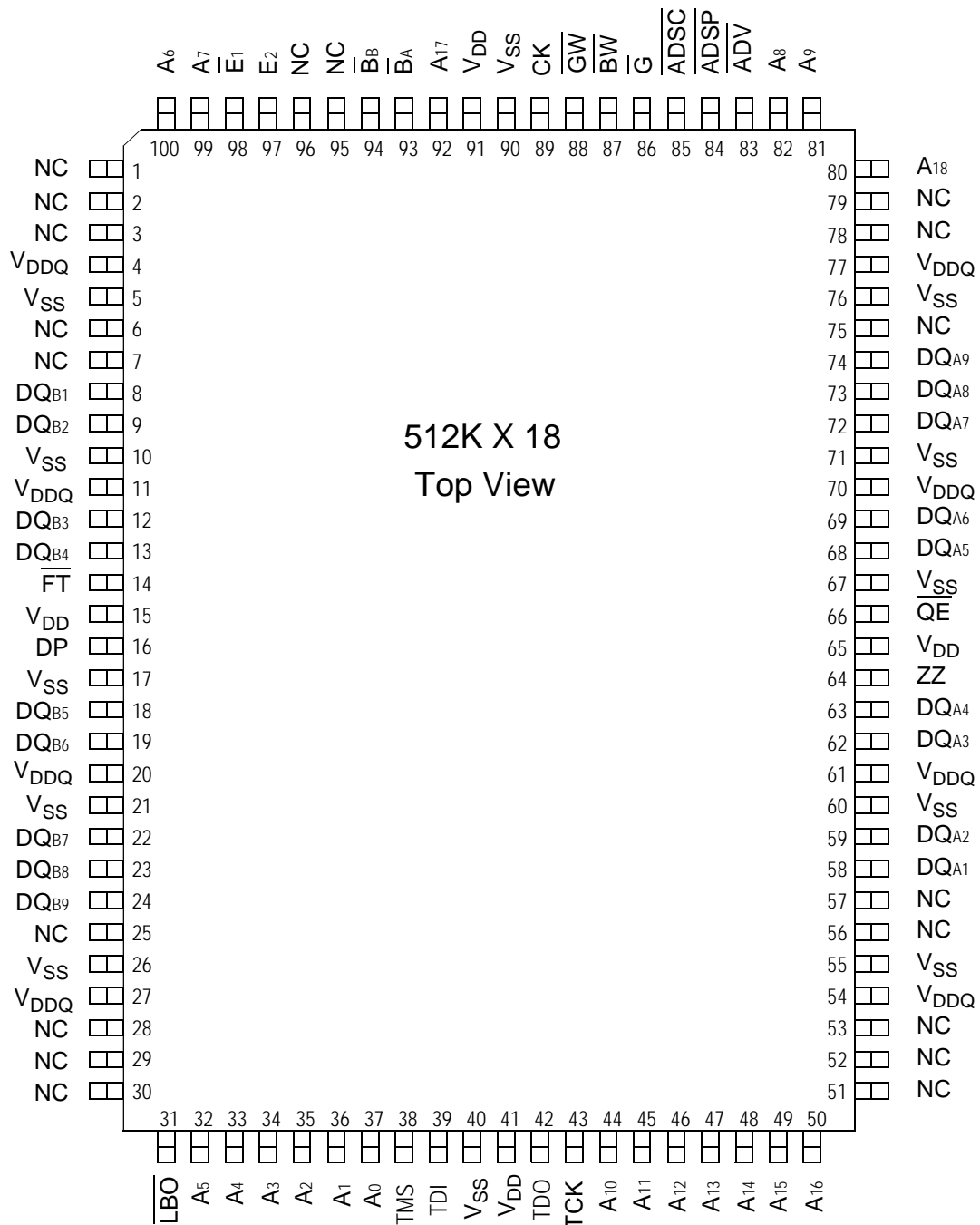

GS88136 100-Pin TQFP Pinout

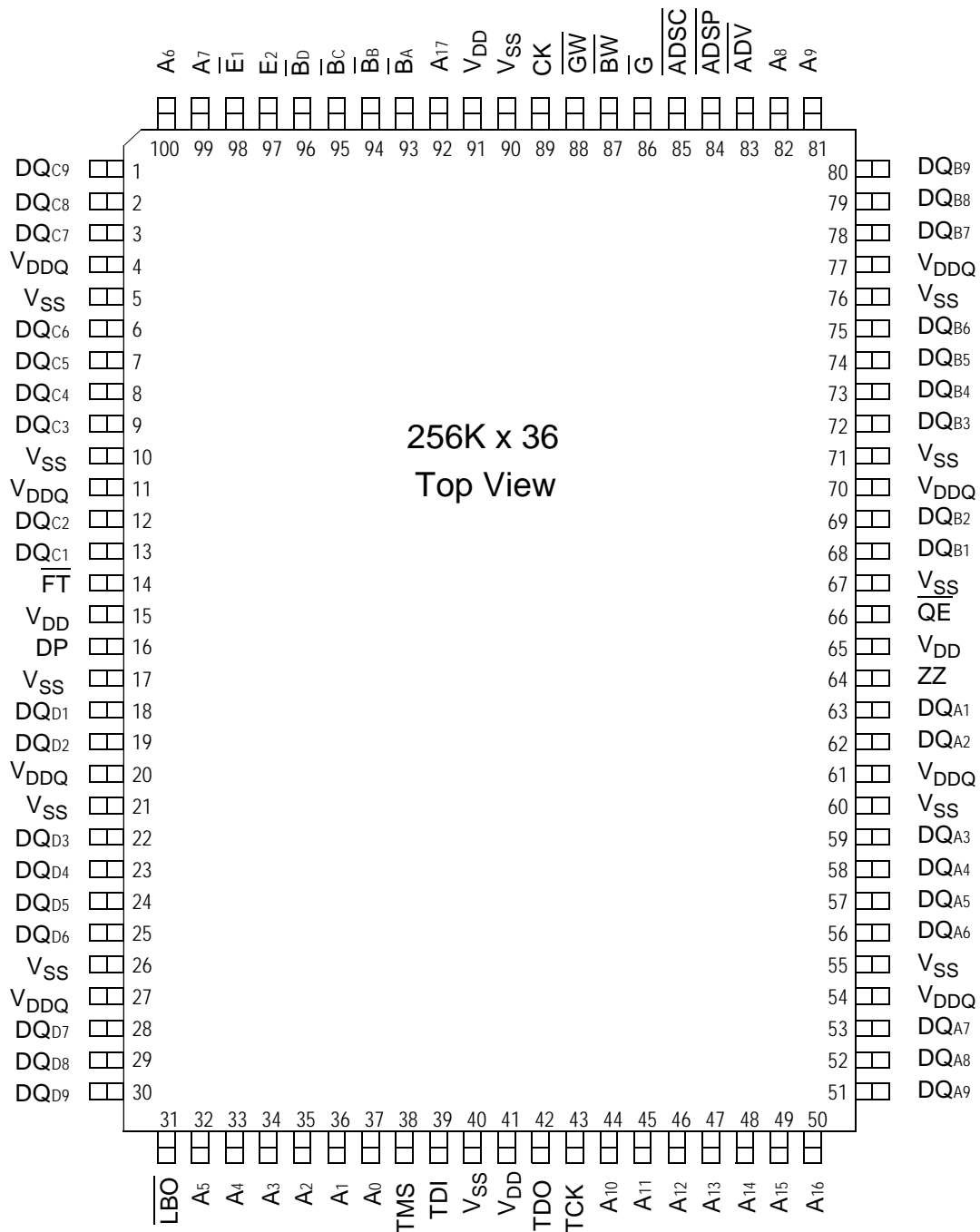

### TQFP Pin Description

Pin Location	Symbol	Type	Description
37, 36	A <sub>0</sub> , A <sub>1</sub>	I	Address field LSBs and Address Counter preset Inputs
35, 34, 33, 32, 100, 99, 82, 81, 44, 45, 46, 47, 48, 49, 50, 92	A <sub>2</sub> –A <sub>17</sub>	I	Address Inputs
80	A <sub>18</sub>	I	Address Inputs
63, 62, 59, 58, 57, 56, 53, 52 68, 69, 72, 73, 74, 75, 78, 79 13, 12, 9, 8, 7, 6, 3, 2 18, 19, 22, 23, 24, 25, 28, 29	DQA <sub>1</sub> –DQA <sub>8</sub> DQB <sub>1</sub> –DQB <sub>8</sub> DQC <sub>1</sub> –DQC <sub>8</sub> DQD <sub>1</sub> –DQD <sub>8</sub>	I/O	Data Input and Output pins ( x36 Version)
51, 80, 1, 30	DQA <sub>9</sub> , DQB <sub>9</sub> , DQC <sub>9</sub> , DQD <sub>9</sub>	I/O	Data Input and Output pins
58, 59, 62, 63, 68, 69, 72, 73, 74 8, 9, 12, 13, 18, 19, 22, 23, 24	DQA <sub>1</sub> –DQA <sub>9</sub> DQB <sub>1</sub> –DQB <sub>9</sub>	I/O	Data Input and Output pins
51, 52, 53, 56, 57 75, 78, 79, 1, 2, 3, 6, 7 25, 28, 29, 30	NC	—	No Connect
16	DP	I	Parity Input; 1 = Even, 0 = Odd
66	QE	O	Parity Error Out; Open Drain Output
87	BW	I	Byte Write—Writes all enabled bytes; active low
93, 94	B <sub>A</sub> , B <sub>B</sub>	I	Byte Write Enable for DQA, DQB Data I/Os; active low
95, 96	B <sub>C</sub> , B <sub>D</sub>	I	Byte Write Enable for DQC, DQD Data I/Os; active low ( x36 Version)
95, 96	NC	—	No Connect (x18 Version)
89	CK	I	Clock Input Signal; active high
88	GW	I	Global Write Enable—Writes all bytes; active low
98	E <sub>1</sub>	I	Chip Enable; active low
97	E <sub>2</sub>	I	Chip Enable; active high
86	G	I	Output Enable; active low
83	ADV	I	Burst address counter advance enable; active low
84, 85	ADSP, ADSC	I	Address Strobe (Processor, Cache Controller); active low

Pin Location	Symbol	Type	Description
64	$\overline{ZZ}$	I	Sleep mode control; active high
14	$\overline{FT}$	I	Flow Through or Pipeline mode; active low
31	$\overline{LBO}$	I	Linear Burst Order mode; active low
38	TMS	I	Scan Test Mode Select
39	TDI	I	Scan Test Data In
42	TDO	O	Scan Test Data Out
43	TCK	I	Scan Test Clock
15, 41, 65, 91	$V_{DD}$	I	Core power supply
5, 10, 17, 21, 26, 40, 55, 60, 67, 71, 76, 90	$V_{SS}$	I	I/O and Core Ground
4, 11, 20, 27, 54, 61, 70, 77	$V_{DDQ}$	I	Output driver power supply

### GS881881E18/36 Block Diagram

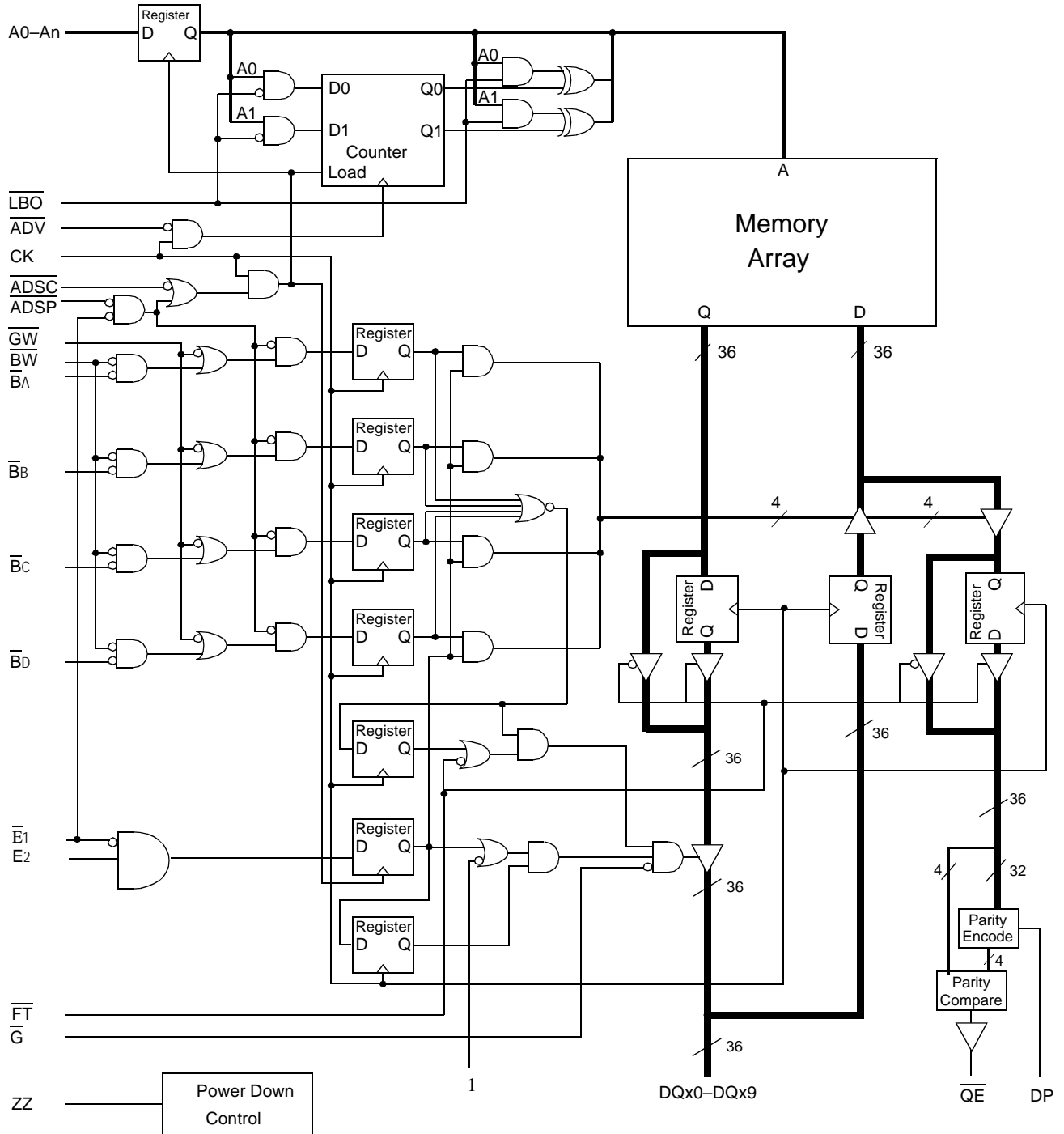

Note: Only x36 version shown for simplicity.

### ByteSafe™ Parity Functions

This SRAM includes a write data parity check that checks the validity of data coming into the RAM on write cycles. In Flow Through mode, write data errors are reported in the cycle following the data input cycle. In Pipeline mode, write data errors are reported one clock cycle later. (See **Write Parity Error Output Timing Diagram**.) The Data Parity Mode (DP) pin must be tied high to set the RAM to check for even parity or low to check for odd parity. Read data parity is not checked by the RAM as data. Validity is best established at the data's destination. The Parity Error Output is an open drain output and drives low to indicate a parity error. Multiple Parity Error Output pins may share a common pull-up resistor.

### Write Parity Error Output Timing Diagram

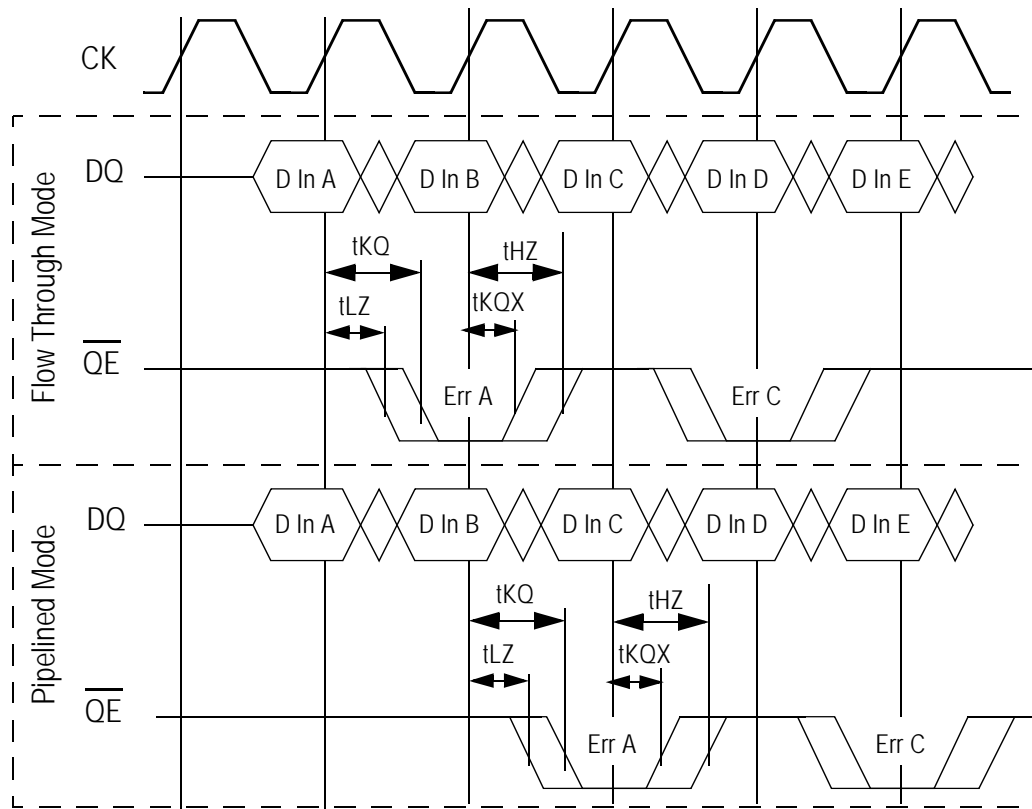

BPR 1999.05.18

### Mode Pin Functions

Mode Name	Pin Name	State	Function
Burst Order Control	$\overline{\text{LBO}}$	L	Linear Burst
		H or NC	Interleaved Burst
Output Register Control	$\overline{\text{FT}}$	L	Flow Through
		H or NC	Pipeline
Power Down Control	ZZ	L or NC	Active
		H	Standby, $I_{DD} = I_{SB}$
ByteSafe Data Parity Control	DP	L	Check for Odd Parity
		H or NC	Check for Even Parity

Note:

There are pull-up devices on the  $\overline{LBO}$ ,  $\overline{DP}$  and  $\overline{FT}$  pins and a pull down device on the  $\overline{ZZ}$  pin, so those input pins can be unconnected and the chip will operate in the default states as specified in the above table.

## Burst Counter Sequences

### Linear Burst Sequence

	A[1:0]	A[1:0]	A[1:0]	A[1:0]
1st address	00	01	10	11
2nd address	01	10	11	00
3rd address	10	11	00	01
4th address	11	00	01	10

Note: The burst counter wraps to initial state on the 5th clock.

### Interleaved Burst Sequence

	A[1:0]	A[1:0]	A[1:0]	A[1:0]
1st address	00	01	10	11
2nd address	01	00	11	10
3rd address	10	11	00	01
4th address	11	10	01	00

Note: The burst counter wraps to initial state on the 5th clock.

BPR 1999.05.18

## Byte Write Truth Table

Function	$\overline{GW}$	$\overline{BW}$	$\overline{B_A}$	$\overline{B_B}$	$\overline{B_C}$	$\overline{B_D}$	Notes
Read	H	H	X	X	X	X	1
Read	H	L	H	H	H	H	1
Write byte a	H	L	L	H	H	H	2, 3
Write byte b	H	L	H	L	H	H	2, 3
Write byte c	H	L	H	H	L	H	2, 3, 4
Write byte d	H	L	H	H	H	L	2, 3, 4
Write all bytes	H	L	L	L	L	L	2, 3, 4
Write all bytes	L	X	X	X	X	X	

Notes:

1. All byte outputs are active in read cycles regardless of the state of Byte Write Enable inputs.
2. Byte Write Enable inputs  $\overline{B_A}$ ,  $\overline{B_B}$ ,  $\overline{B_C}$ , and/or  $\overline{B_D}$  may be used in any combination with  $\overline{BW}$  to write single or multiple bytes.
3. All byte I/Os remain High-Z during all write operations regardless of the state of Byte Write Enable inputs.
4. Bytes "c" and "d" are only available on the x36 version.



### Synchronous Truth Table

Operation	Address Used	State Diagram Key <sup>5</sup>	$\overline{E1}$	$E2^2$ (x36only)	$\overline{ADSP}$	$\overline{ADSC}$	$\overline{ADV}$	$W^3$	$DQ^4$
<b>Deselect Cycle, Power Down</b>	<b>None</b>	<b>X</b>	<b>H</b>	<b>X</b>	<b>X</b>	<b>L</b>	<b>X</b>	<b>X</b>	<b>High-Z</b>
Deselect Cycle, Power Down	None	X	L	F	L	X	X	X	High-Z
<b>Deselect Cycle, Power Down</b>	<b>None</b>	<b>X</b>	<b>L</b>	<b>F</b>	<b>H</b>	<b>L</b>	<b>X</b>	<b>X</b>	<b>High-Z</b>
Read Cycle, Begin Burst	External	R	L	T	L	X	X	X	Q
<b>Read Cycle, Begin Burst</b>	<b>External</b>	<b>R</b>	<b>L</b>	<b>T</b>	<b>H</b>	<b>L</b>	<b>X</b>	<b>F</b>	<b>Q</b>
<b>Write Cycle, Begin Burst</b>	<b>External</b>	<b>W</b>	<b>L</b>	<b>T</b>	<b>H</b>	<b>L</b>	<b>X</b>	<b>T</b>	<b>D</b>
<i>Read Cycle, Continue Burst</i>	<i>Next</i>	<i>CR</i>	<i>X</i>	<i>X</i>	<i>H</i>	<i>H</i>	<i>L</i>	<i>F</i>	<i>Q</i>
Read Cycle, Continue Burst	Next	CR	H	X	X	H	L	F	Q
<i>Write Cycle, Continue Burst</i>	<i>Next</i>	<i>CW</i>	<i>X</i>	<i>X</i>	<i>H</i>	<i>H</i>	<i>L</i>	<i>T</i>	<i>D</i>
Write Cycle, Continue Burst	Next	CW	H	X	X	H	L	T	D
Read Cycle, Suspend Burst	Current		X	X	H	H	H	F	Q
Read Cycle, Suspend Burst	Current		H	X	X	H	H	F	Q
Write Cycle, Suspend Burst	Current		X	X	H	H	H	T	D
Write Cycle, Suspend Burst	Current		H	X	X	H	H	T	D

Notes:

1. X = Don't Care, H = High, L = Low.
2. For x36 Version, E = T (True) if E2 = 1; E = F (False) if E2 = 0.
3.  $\overline{W}$  = T (True) and F (False) is defined in the Byte Write Truth Table preceding.
4.  $\overline{G}$  is an asynchronous input.  $\overline{G}$  can be driven high at any time to disable active output drivers.  $\overline{G}$  low can only enable active drivers (shown as "Q" in the Truth Table above).
5. All input combinations shown above are tested and supported. Input combinations shown in gray boxes need not be used to accomplish basic synchronous or synchronous burst operations and may be avoided for simplicity.
6. Tying  $\overline{ADSP}$  high and  $\overline{ADSC}$  low allows simple non-burst synchronous operations. See **BOLD** items above.
7. Tying  $\overline{ADSP}$  high and  $\overline{ADV}$  low while using  $\overline{ADSC}$  to load new addresses allows simple burst operations. See *ITALIC* items above.

## Simplified State Diagram

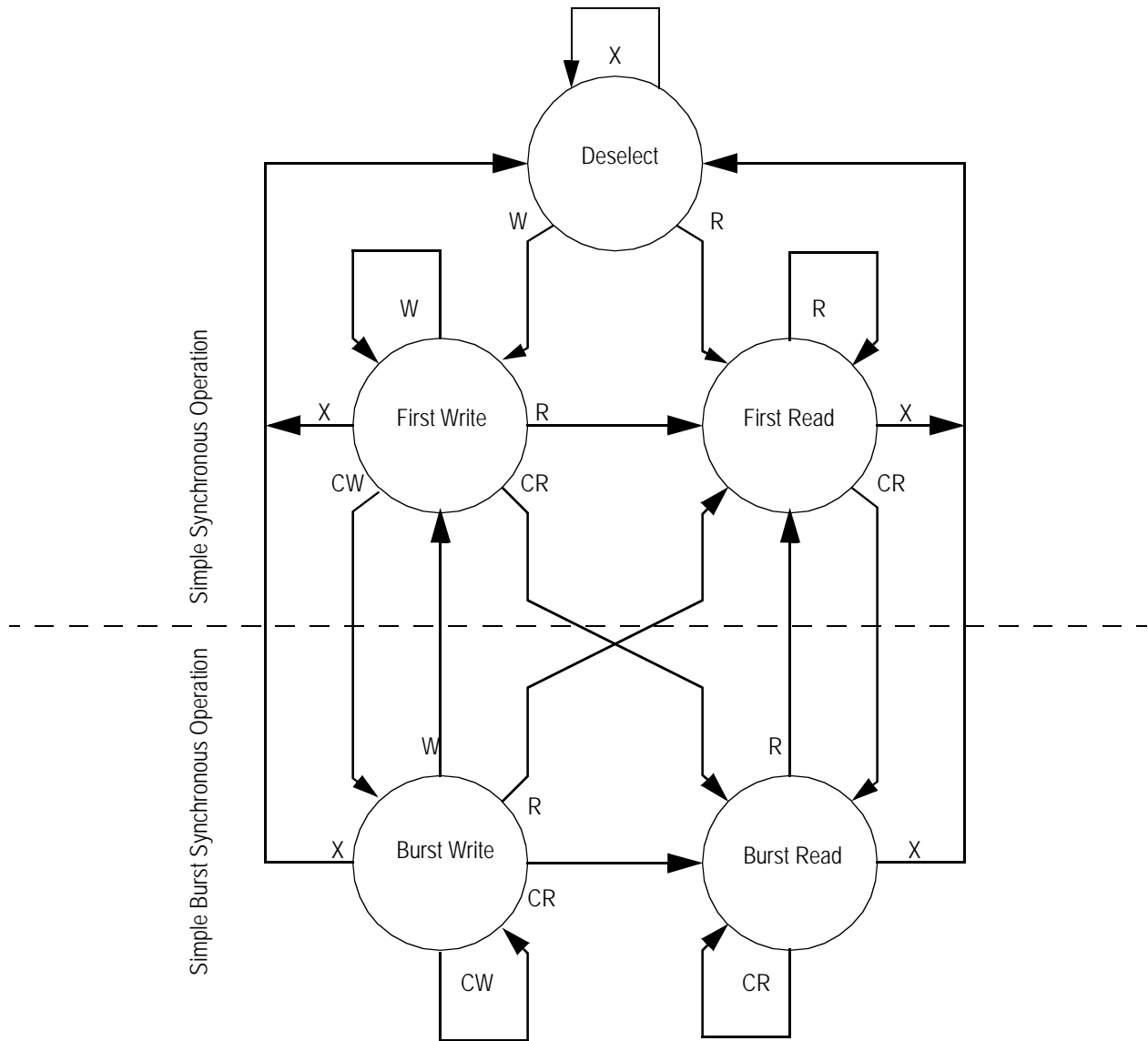

Notes:

1. The diagram shows only supported (tested) synchronous state transitions. The diagram presumes  $\overline{G}$  is tied low.
2. The upper portion of the diagram assumes active use of only the Enable ( $\overline{E1}$  and  $\overline{E2}$ ) and Write ( $\overline{B_A}$ ,  $\overline{B_B}$ ,  $\overline{B_C}$ ,  $\overline{B_D}$ ,  $\overline{B_W}$ , and  $\overline{G_W}$ ) control inputs, and that  $\overline{ADSP}$  is tied high and  $\overline{ADSC}$  is tied low.
3. The upper and lower portions of the diagram together assume active use of only the Enable, Write, and  $\overline{ADSC}$  control inputs, and assumes  $\overline{ADSP}$  is tied high and  $\overline{ADV}$  is tied low.

## Simplified State Diagram with $\overline{G}$

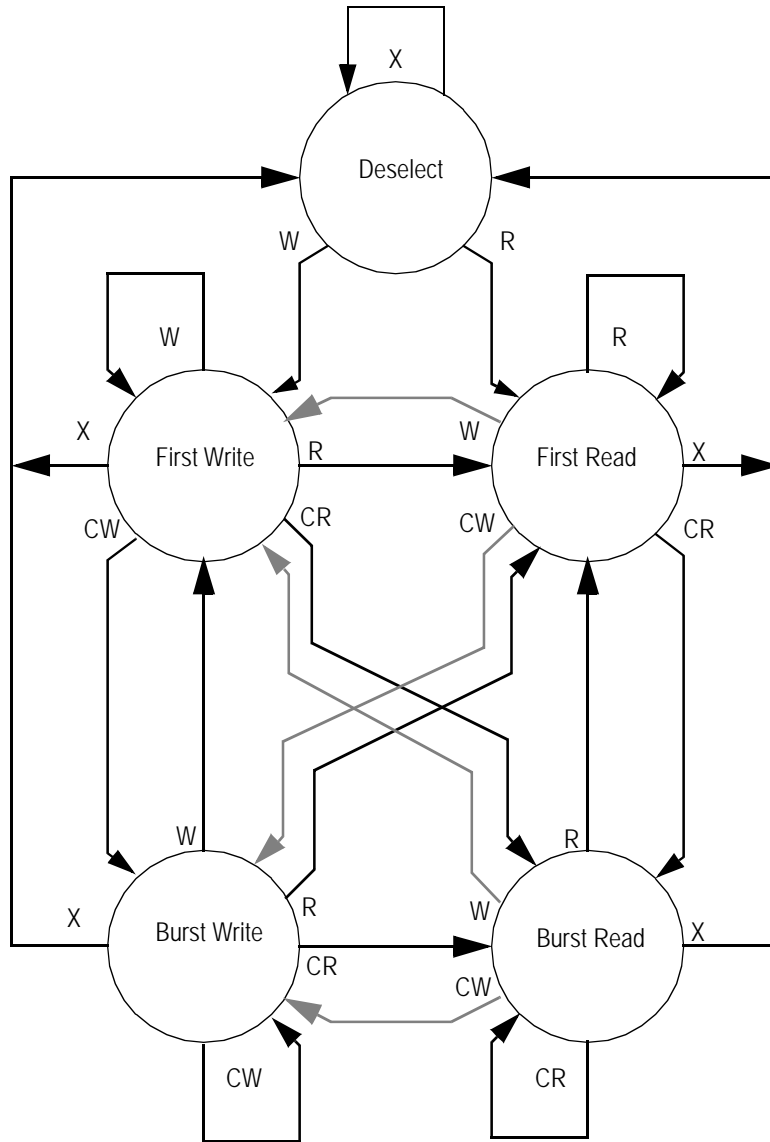

### Notes:

1. The diagram shows supported (tested) synchronous state transitions plus supported transitions that depend upon the use of  $\overline{G}$ .
2. Use of "Dummy Reads" (Read Cycles with  $\overline{G}$  High) may be used to make the transition from Read cycles to Write cycles without passing through a Deselect cycle. Dummy Read cycles increment the address counter just like normal Read cycles.
3. Transitions shown in grey tone assume  $\overline{G}$  has been pulsed high long enough to turn the RAM's drivers off and for incoming data to meet Data Input Set Up Time.

### Absolute Maximum Ratings

(All voltages reference to  $V_{SS}$ )

Symbol	Description	Value	Unit
$V_{DD}$	Voltage on $V_{DD}$ Pins	-0.5 to 4.6	V
$V_{DDQ}$	Voltage in $V_{DDQ}$ Pins	-0.5 to $V_{DD}$	V
$V_{CK}$	Voltage on Clock Input Pin	-0.5 to 6	V
$V_{I/O}$	Voltage on I/O Pins	-0.5 to $V_{DDQ} + 0.5$ ( $\leq 4.6$ V max.)	V
$V_{IN}$	Voltage on Other Input Pins	-0.5 to $V_{DD} + 0.5$ ( $\leq 4.6$ V max.)	V
$I_{IN}$	Input Current on Any Pin	+/-20	mA
$I_{OUT}$	Output Current on Any I/O Pin	+/-20	mA
$P_D$	Package Power Dissipation	1.5	W
$T_{STG}$	Storage Temperature	-55 to 125	$^{\circ}C$
$T_{BIAS}$	Temperature Under Bias	-55 to 125	$^{\circ}C$

**Note:**

Permanent damage to the device may occur if the Absolute Maximum Ratings are exceeded. Operation should be restricted to Recommended Operating Conditions. Exposure to conditions exceeding the Absolute Maximum Ratings, for an extended period of time, may affect reliability of this component.

### Recommended Operating Conditions

Parameter	Symbol	Min.	Typ.	Max.	Unit	Notes
Supply Voltage	$V_{DD}$	3.135	3.3	3.6	V	
I/O Supply Voltage	$V_{DDQ}$	2.375	2.5	$V_{DD}$	V	1
Input High Voltage	$V_{IH}$	1.7	—	$V_{DD} + 0.3$	V	2
Input Low Voltage	$V_{IL}$	-0.3	—	0.8	V	2
Ambient Temperature (Commercial Range Versions)	$T_A$	0	25	70	$^{\circ}C$	3
Ambient Temperature (Industrial Range Versions)	$T_A$	-40	25	85	$^{\circ}C$	3

**Notes:**

- Unless otherwise noted, all performance specifications quoted are evaluated for worst case at both  $2.75\text{ V} \leq V_{DDQ} \leq 2.375\text{ V}$  (i.e., 2.5 V I/O) and  $3.6\text{ V} \leq V_{DD} \leq 3.135\text{ V}$  (i.e., 3.3 V I/O), and quoted at whichever condition is worst case.
- This device features input buffers compatible with both 3.3 V and 2.5 V I/O drivers.
- Most speed grades and configurations of this device are offered in both Commercial and Industrial Temperature ranges. The part number of Industrial Temperature Range versions end the character "I". Unless otherwise noted, all performance specifications quoted are evaluated for worst case in the temperature range marked on the device.
- Input Under/overshoot voltage must be  $-2\text{ V} > V_i < V_{DD} + 2\text{ V}$  with a pulse width not to exceed 20% tKC.

### Undershoot Measurement and Timing

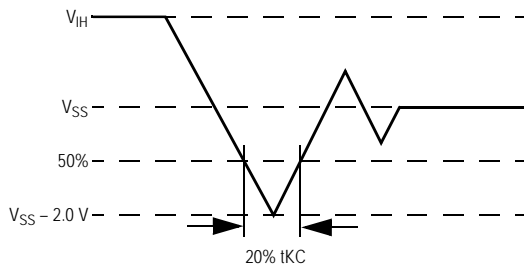

### Overshoot Measurement and Timing

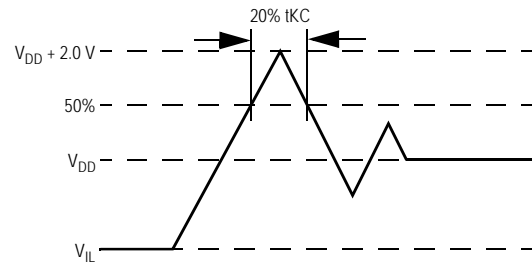

### Capacitance

( $T_A = 25^\circ\text{C}$ ,  $f = 1\text{ MHz}$ ,  $V_{DD} = 3.3\text{ V}$ )

Parameter	Symbol	Test conditions	Typ.	Max.	Unit
Input Capacitance	$C_{IN}$	$V_{IN} = 0\text{ V}$	4	5	pF
Input/Output Capacitance	$C_{I/O}$	$V_{OUT} = 0\text{ V}$	6	7	pF

Note: These parameters are sample tested.

### Package Thermal Characteristics

Rating	Layer Board	Symbol	Max	Unit	Notes
Junction to Ambient (at 200 lfm)	single	$R_{\theta JA}$	40	$^\circ\text{C/W}$	1,2
Junction to Ambient (at 200 lfm)	four	$R_{\theta JA}$	24	$^\circ\text{C/W}$	1,2
Junction to Case (TOP)	—	$R_{\theta JC}$	9	$^\circ\text{C/W}$	3

Notes:

- Junction temperature is a function of SRAM power dissipation, package thermal resistance, mounting board temperature, ambient. Temperature air flow, board density, and PCB thermal resistance.
- SCMI G-38-87
- Average thermal resistance between die and top surface, MIL SPEC-883, Method 1012.1

### AC Test Conditions

Parameter	Conditions
Input high level	2.3 V
Input low level	0.2 V
Input slew rate	1 V/ns
Input reference level	1.25 V
Output reference level	1.25 V
Output load	<b>Fig. 1 &amp; 2</b>

Notes:

1. Include scope and jig capacitance.
2. Test conditions as specified with output loading as shown in **Fig. 1** unless otherwise noted.
3. Output Load 2 for  $t_{LZ}$ ,  $t_{HZ}$ ,  $t_{OLZ}$  and  $t_{OHZ}$
4. Device is deselected as defined by the Truth Table.

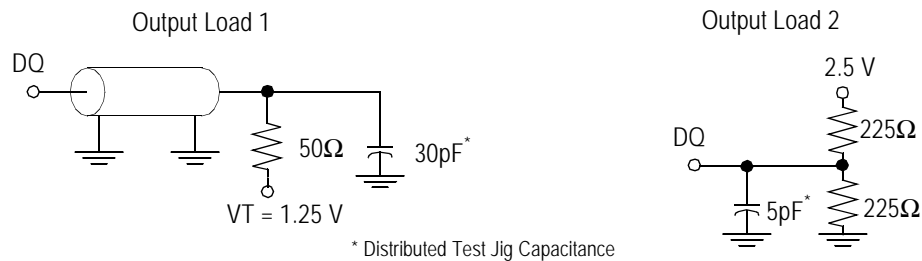

### DC Electrical Characteristics

Parameter	Symbol	Test Conditions	Min	Max
Input Leakage Current (except mode pins)	$I_{IL}$	$V_{IN} = 0 \text{ to } V_{DD}$	-1 $\mu\text{A}$	1 $\mu\text{A}$
ZZ Input Current	$I_{INZZ}$	$V_{DD} \geq V_{IN} \geq V_{IH}$ $0 \text{ V} \leq V_{IN} \leq V_{IH}$	-1 $\mu\text{A}$ -1 $\mu\text{A}$	1 $\mu\text{A}$ 300 $\mu\text{A}$
Mode Pin Input Current	$I_{INM}$	$V_{DD} \geq V_{IN} \geq V_{IL}$ $0 \text{ V} \leq V_{IN} \leq V_{IL}$	-300 $\mu\text{A}$ -1 $\mu\text{A}$	1 $\mu\text{A}$ 1 $\mu\text{A}$
Output Leakage Current	$I_{OL}$	Output Disable, $V_{OUT} = 0 \text{ to } V_{DD}$	-1 $\mu\text{A}$	1 $\mu\text{A}$
Output High Voltage	$V_{OH}$	$I_{OH} = -8 \text{ mA}$ , $V_{DDQ} = 2.375 \text{ V}$	1.7 V	—
Output High Voltage	$V_{OH}$	$I_{OH} = -8 \text{ mA}$ , $V_{DDQ} = 3.135 \text{ V}$	2.4 V	—
Output Low Voltage	$V_{OL}$	$I_{OL} = 8 \text{ mA}$	—	0.4 V

### Operating Currents

Parameter	Test Conditions	Symbol	-11		-11.5		-100		-80		-66		Unit
			0 to 70°C	-40 to 85°C	0 to 70°C	-40 to 85°C	0 to 70°C	-40 to 85°C	0 to 70°C	-40 to 85°C	0 to 70°C	-40 to 85°C	
Operating Current	Device Selected; All other inputs $\geq V_{IH}$ or $\leq V_{IL}$ Output open	$I_{DD}$ Pipeline	225	235	225	235	225	235	200	210	185	195	mA
		$I_{DD}$ Flow-Thru	180	190	180	190	180	190	175	185	165	175	mA
Standby Current	$ZZ \geq V_{DD} - 0.2V$	$I_{SB}$ Pipeline	30	40	30	40	30	40	30	40	30	40	mA
		$I_{SB}$ Flow-Thru	30	40	30	40	30	40	30	40	30	40	mA
Deselect Current	Device Deselected; All other inputs $\geq V_{IH}$ or $\leq V_{IL}$	$I_{DD}$ Pipeline	80	90	80	90	80	90	70	80	60	70	mA
		$I_{DD}$ Flow-Thru	65	75	65	75	65	75	55	65	50	60	mA

## AC Electrical Characteristics

	Parameter	Symbol	-11		-11.5		-100		-80		-66		Unit
			Min	Max	Min	Max	Min	Max	Min	Max	Min	Max	
Pipeline	Clock Cycle Time	t <sub>KC</sub>	10	—	10	—	10	—	12.5	—	15	—	ns
	Clock to Output Valid	t <sub>KQ</sub>	—	4.0	—	4.0	—	4.0	—	4.5	—	5	ns
	Clock to Output Invalid	t <sub>KQX</sub>	1.5	—	1.5	—	1.5	—	1.5	—	1.5	—	ns
	Clock to Output in Low-Z	t <sub>LZ</sub> <sup>1</sup>	1.5	—	1.5	—	1.5	—	1.5	—	1.5	—	ns
Flow-Thru	Clock Cycle Time	t <sub>KC</sub>	15.0	—	15.0	—	15.0	—	15.0	—	20	—	ns
	Clock to Output Valid	t <sub>KQ</sub>	—	11.0	—	11.5	—	12.0	—	14.0	—	18	ns
	Clock to Output Invalid	t <sub>KQX</sub>	3.0	—	3.0	—	3.0	—	3.0	—	3.0	—	ns
	Clock to Output in Low-Z	t <sub>LZ</sub> <sup>1</sup>	3.0	—	3.0	—	3.0	—	3.0	—	3.0	—	ns
	Clock HIGH Time	t <sub>KH</sub>	1.7	—	1.7	—	2	—	2	—	2.3	—	ns
	Clock LOW Time	t <sub>KL</sub>	2	—	2	—	2.2	—	2.2	—	2.5	—	ns
	Clock to Output in High-Z	t <sub>HZ</sub> <sup>1</sup>	1.5	4.0	1.5	4.2	1.5	4.5	1.5	4.5	1.5	4.8	ns
	$\bar{G}$ to Output Valid	t <sub>OE</sub>	—	4.0	—	4.2	—	4.5	—	4.5	—	4.8	ns
	$\bar{G}$ to output in Low-Z	t <sub>OLZ</sub> <sup>1</sup>	0	—	0	—	0	—	0	—	0	—	ns
	$\bar{G}$ to output in High-Z	t <sub>OHZ</sub> <sup>1</sup>	—	4.0	—	4.2	—	4.5	—	4.5	—	4.8	ns
	Setup time	t <sub>S</sub>	1.5	—	2.0	—	2.0	—	2.0	—	2.0	—	ns
	Hold time	t <sub>H</sub>	0.5	—	0.5	—	0.5	—	0.5	—	0.5	—	ns
	ZZ setup time	t <sub>ZZS</sub> <sup>2</sup>	5	—	5	—	5	—	5	—	5	—	ns
	ZZ hold time	t <sub>ZZH</sub> <sup>2</sup>	1	—	1	—	1	—	1	—	1	—	ns
	ZZ recovery	t <sub>ZZR</sub>	20	—	20	—	20	—	20	—	20	—	ns

Notes:

1. These parameters are sampled and are not 100% tested.
2. ZZ is an asynchronous signal. However, in order to be recognized on any given clock cycle, ZZ must meet the specified setup and hold times as specified above.



## Write Cycle Timing

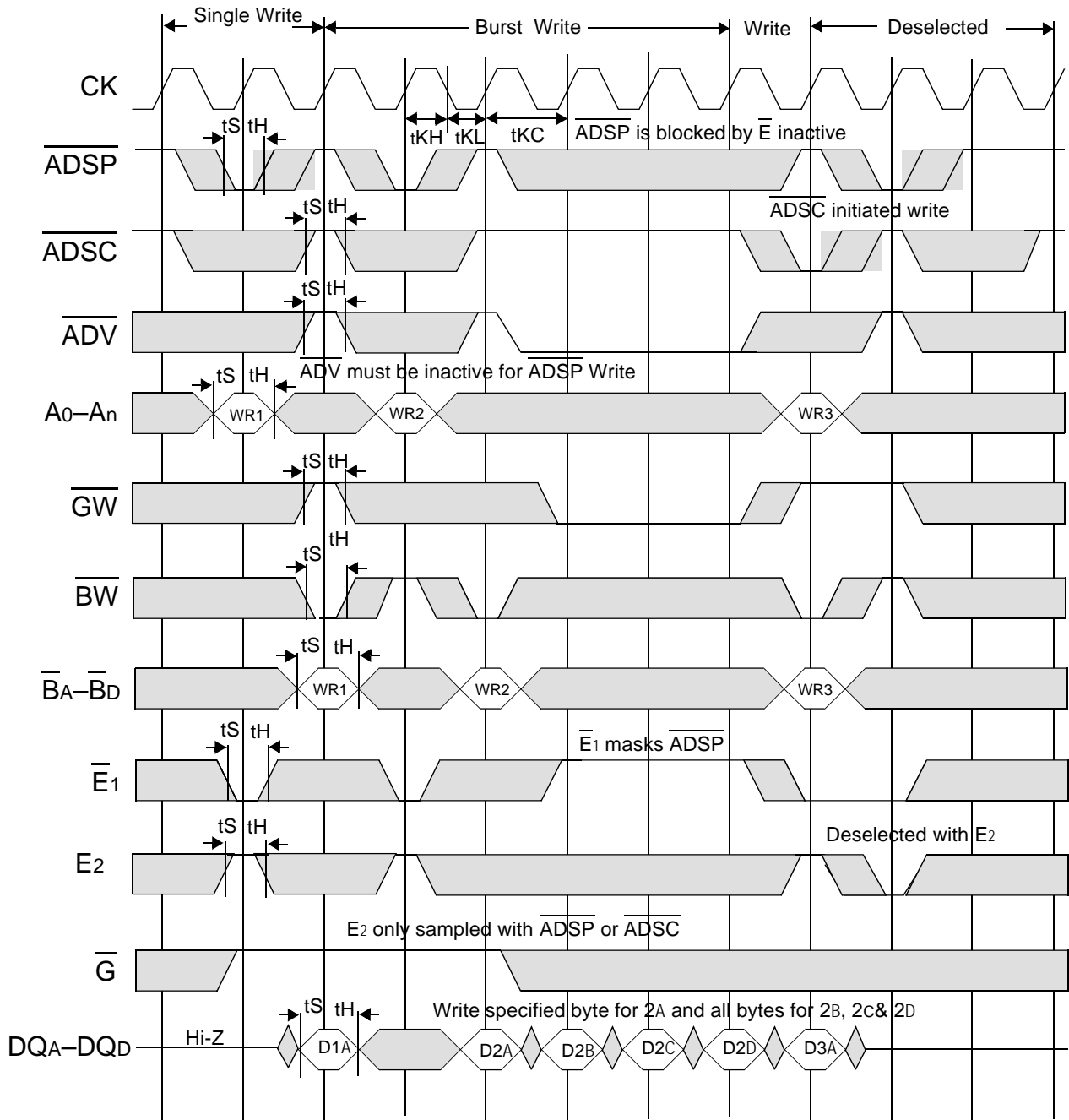

## Flow Through Read Cycle Timing

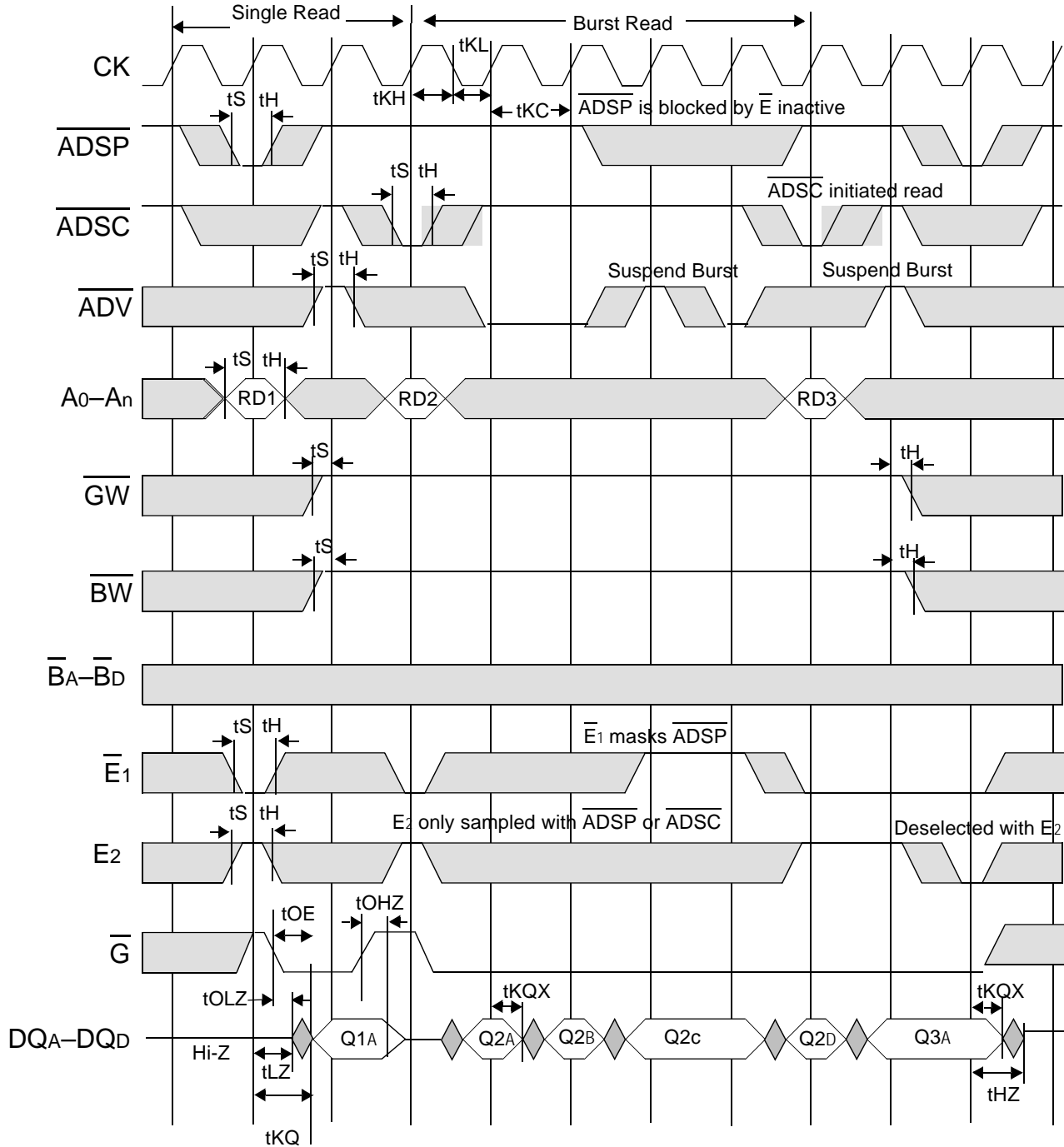

### Flow Through Read-Write Cycle Timing

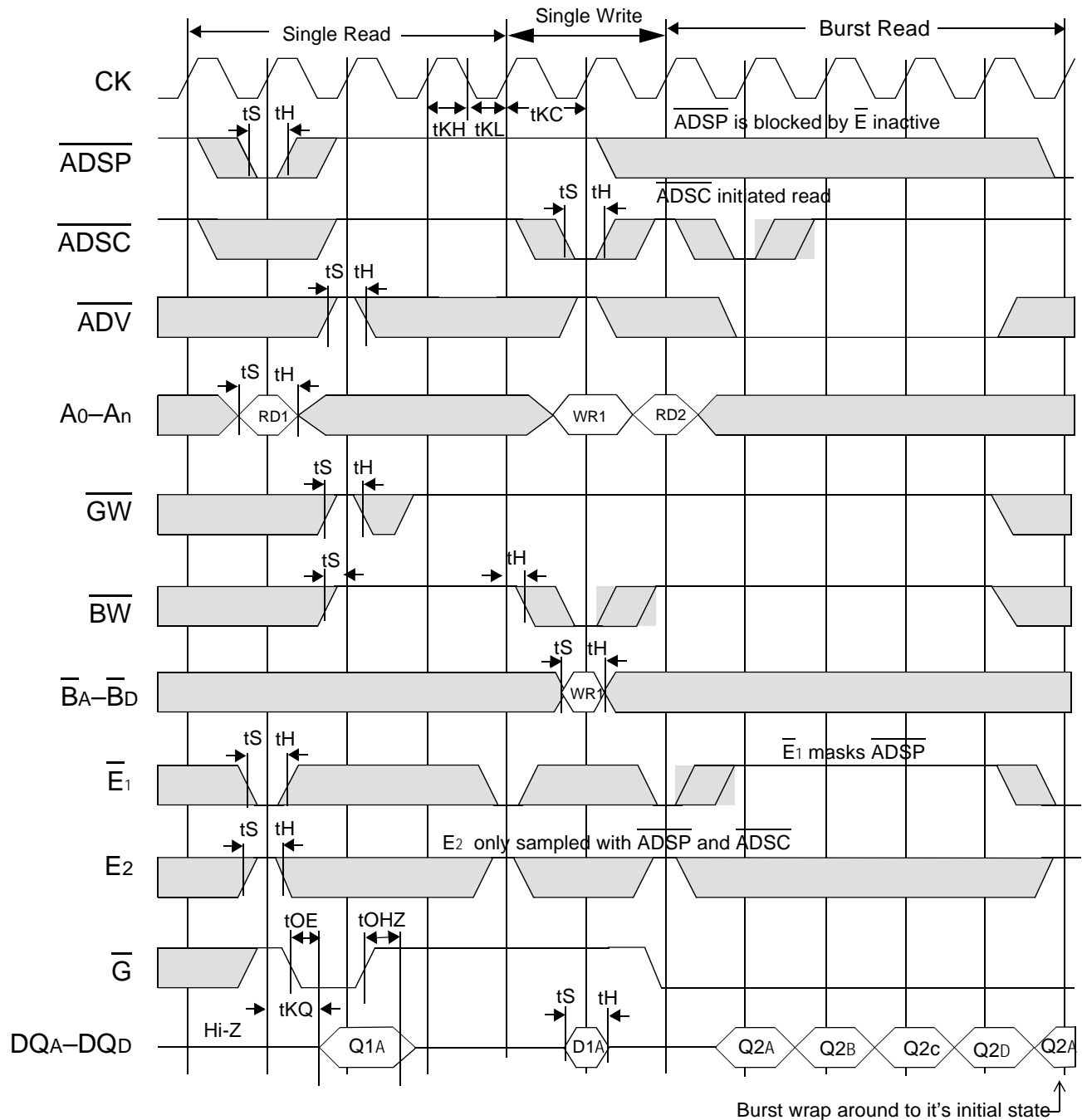

### Pipelined SCD Read-Write Cycle Timing

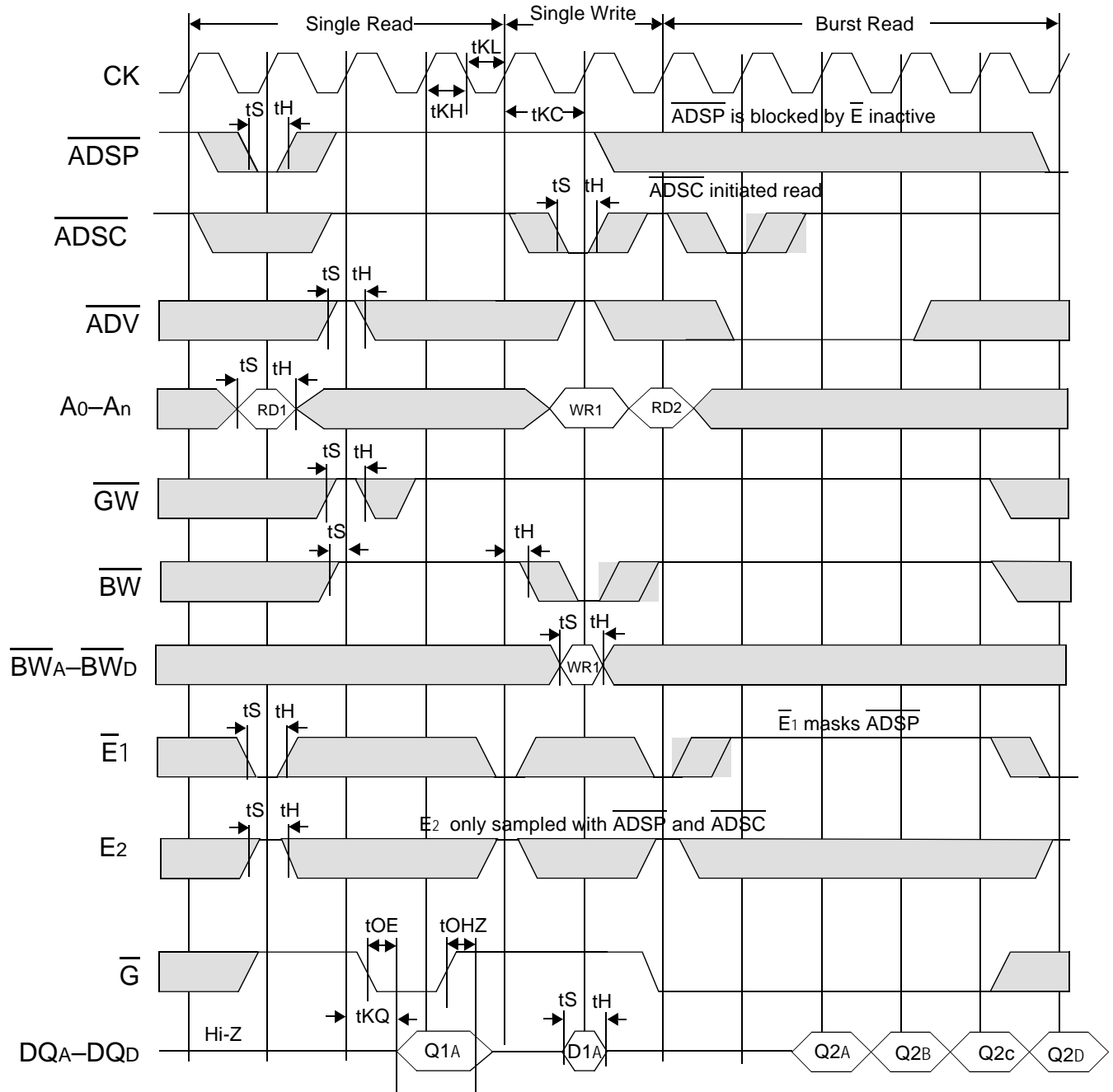

### Pipelined SCD Read Cycle Timing

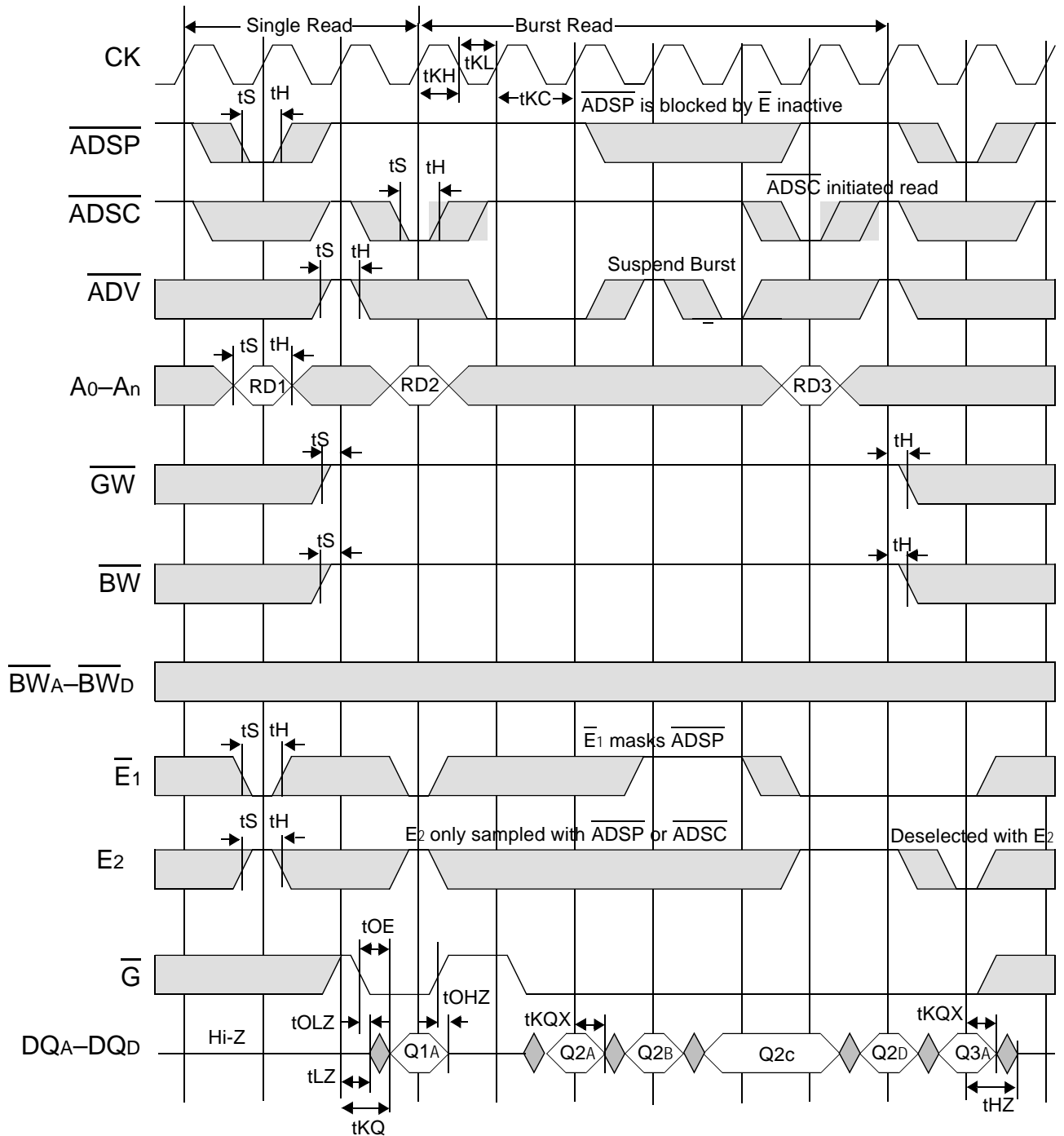

## Sleep Mode Timing Diagram

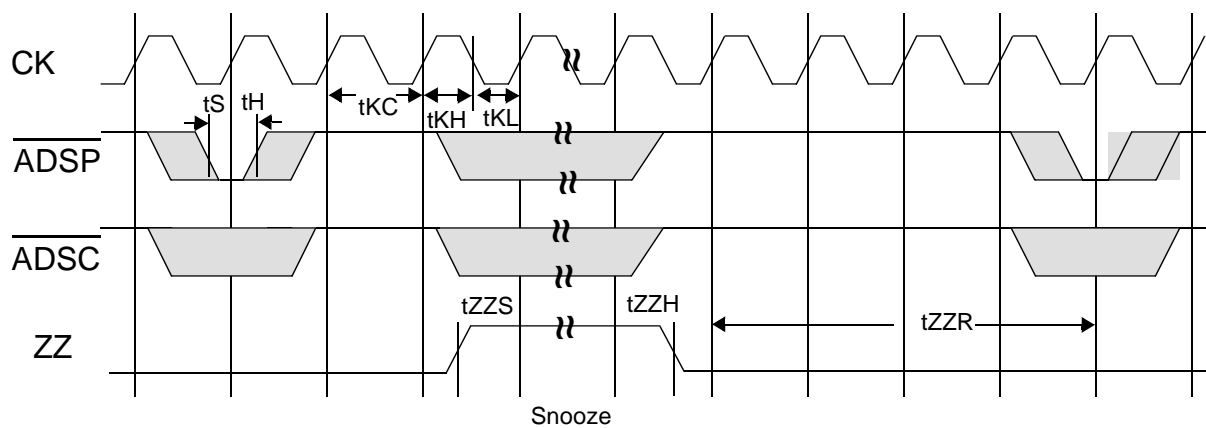

## Application Tips

### Single and Dual Cycle Deselect

SCD devices force the use of “dummy read cycles” (read cycles that are launched normally but that are ended with the output drivers inactive) in a fully synchronous environment. Dummy read cycles waste performance but their use usually assures there will be no bus contention in transitions from reads to writes or between banks of RAMs. DCD SRAMs do not waste bandwidth on dummy cycles and are logically simpler to manage in a multiple bank application (wait states need not be inserted at bank address boundary crossings) but greater care must be exercised to avoid excessive bus contention.

## JTAG Port Operation

### Overview

The JTAG Port on this RAM operates in a manner consistent with IEEE Standard 1149.1-1990, a serial boundary scan interface standard (commonly referred to as JTAG), but does not implement all of the functions required for 1149.1 compliance. Some functions have been modified or eliminated because they can slow the RAM. Nevertheless, the RAM supports 1149.1-1990 TAP (Test Access Port) Controller architecture, and can be expected to function in a manner that does not conflict with the operation of Standard 1149.1 compliant devices. The JTAG Port interfaces with conventional TTL / CMOS logic level signaling.

### Disabling the JTAG Port

It is possible to use this device without utilizing the JTAG port. The port is reset at power-up and will remain inactive unless clocked. TCK, TDI, and TMS are designed with internal pull-up circuits. To assure normal operation of the RAM with the JTAG Port unused, TCK, TDI, and TMS may be left floating or tied to either  $V_{DD}$  or  $V_{SS}$ . TDO should be left unconnected.

## JTAG Pin Descriptions

Pin	Pin Name	I/O	Description
TCK	Test Clock	In	Clocks all TAP events. All inputs are captured on the rising edge of TCK and all outputs propagate from the falling edge of TCK.
TMS	Test Mode Select	In	The TMS input is sampled on the rising edge of TCK. This is the command input for the TAP controller state machine. An undriven TMS input will produce the same result as a logic one input level.
TDI	Test Data In	In	The TDI input is sampled on the rising edge of TCK. This is the input side of the serial registers placed between TDI and TDO. The register placed between TDI and TDO is determined by the state of the TAP Controller state machine and the instruction that is currently loaded in the TAP Instruction Register (refer to the TAP Controller State Diagram). An undriven TDI pin will produce the same result as a logic one input level.
TDO	Test Data Out	Out	Output that is active depending on the state of the TAP state machine. Output changes in response to the falling edge of TCK. This is the output side of the serial registers placed between TDI and TDO.

**Note:**

This device does not have a TRST (TAP Reset) pin. TRST is optional in IEEE 1149.1. The Test-Logic-Reset state is entered while TMS is held high for five rising edges of TCK. The TAP Controller is also reset automatically at power-up.

## JTAG Port Registers

### Overview

The various JTAG registers, referred to as TAP Registers, are selected (one at a time) via the sequences of 1s and 0s applied to TMS as TCK is strobed. Each of the TAP Registers are serial shift registers that capture serial input data on the rising edge of TCK and push serial data out on the next falling edge of TCK. When a register is selected it is placed between the TDI and TDO pins.

### Instruction Register

The Instruction Register holds the instructions that are executed by the TAP controller when it is moved into the Run, Test/Idle or the various data register states. Instructions are 3 bits long. The Instruction Register can be loaded when it is placed between the TDI and TDO pins. The Instruction Register is automatically preloaded with the IDCODE instruction at power-up or whenever the controller is placed in Test-Logic-Reset state.

### Bypass Register

The Bypass Register is a single-bit register that can be placed between TDI and TDO. It allows serial test data to be passed through the RAMs JTAG Port to another device in the scan chain with as little delay as possible.

### Boundary Scan Register

Boundary Scan Register is a collection of flip flops that can be preset by the logic level found on the RAM's input or I/O pins. The flip flops are then daisy chained together so the levels found can be shifted serially out of the JTAG Port's TDO pin. The Boundary Scan Register also includes a number of place holder flip flops (always set to a logic 1). The relationship between the device pins and the bits in the Boundary Scan Register is described in the Scan Order Table following. The Boundary Scan Register, under the control of the TAP Controller, is loaded with the contents of the RAMs I/O ring when the controller is in Capture-DR state and then is placed between the TDI and TDO pins when the controller is moved to Shift-DR state. Two TAP instructions can be used to activate the Boundary Scan Register.

## JTAG TAP Block Diagram

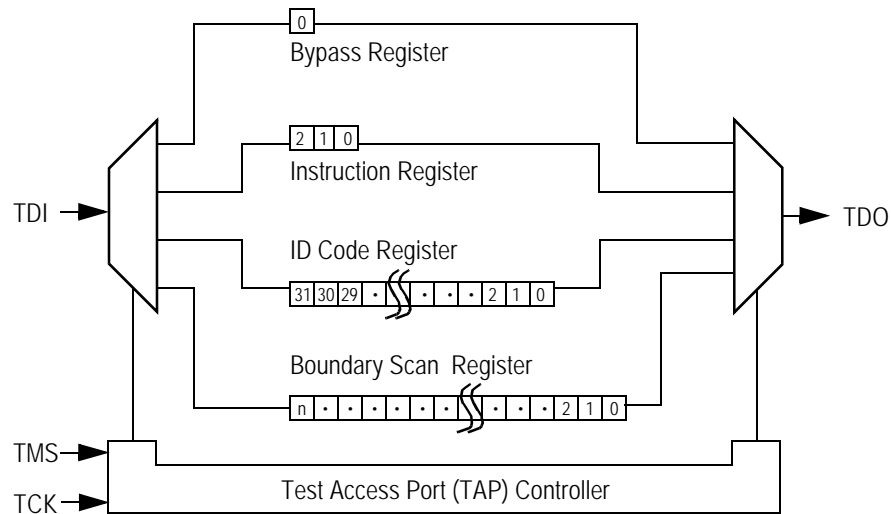

### Identification (ID) Register

The ID Register is a 32-bit register that is loaded with a device and vendor specific 32-bit code when the controller is put in Capture-DR state with the IDCODE command loaded in the Instruction Register. The code is loaded from a 32-bit on-chip ROM. It describes various attributes of the RAM as indicated below. The register is then placed between the TDI and TDO pins when the controller is moved into Shift-DR state. Bit 0 in the register is the LSB and the first to reach TDO when shifting begins.

### ID Register Contents

Bit #	Die Revision Code				Not Used												I/O Configuration				GSI Technology JEDEC Vendor ID Code								Presence Register			
	31	30	29	28	27	26	25	24	23	22	21	20	19	18	17	16	15	14	13	12	1	10	9	8	7	6	5	4		3	2	1
x36	X	X	X	X	0	0	0	0	0	0	0	0	0	0	0	0	0	0	0	1	0	0	0	1	1	0	1	1	0	0	1	1
x18	X	X	X	X	0	0	0	0	0	0	0	0	0	0	0	0	0	1	1	0	0	0	1	1	0	1	1	0	0	1	1	

### Tap Controller Instruction Set

#### Overview

There are two classes of instructions defined in the Standard 1149.1-1990; the standard (Public) instructions, and device specific (Private) instructions. Some Public instructions, are mandatory for 1149.1 compliance. Optional Public instructions must be implemented in prescribed ways. Although the TAP controller in this device follows the 1149.1 conventions, it is not 1194.1-compliant because some of the mandatory instructions are not fully implemented. The TAP on this device may be used to monitor all input and I/O pads, but cannot be used to load address, data or control signals into the RAM or to preload the I/O buffers. This device will not perform EXTEST, INTEST or the SAMPLE/PRELOAD command.

When the TAP controller is placed in Capture-IR state the two least significant bits of the instruction register are loaded with 01. When the controller is moved to the Shift-IR state the Instruction Register is placed between TDI and TDO. In this state the desired



instruction is serially loaded through the TDI input (while the previous contents are shifted out at TDO). For all instructions, the TAP executes newly loaded instructions only when the controller is moved to Update-IR state. The TAP instruction set for this device is listed in the following table.

### JTAG Tap Controller State Diagram

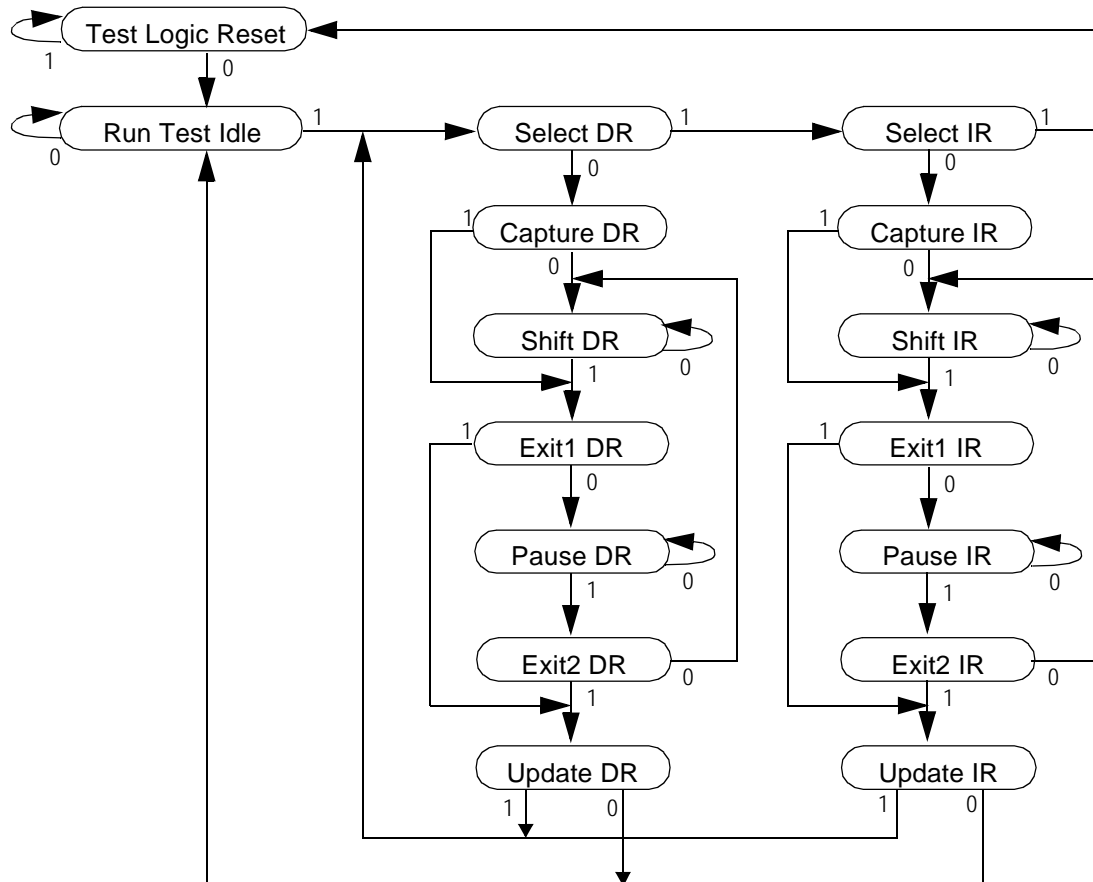

### Instruction Descriptions

#### BYPASS

When the BYPASS instruction is loaded in the Instruction Register the Bypass Register is placed between TDI and TDO. This occurs when the TAP controller is moved to the Shift-DR state. This allows the board level scan path to be shortened to facilitate testing of other devices in the scan path.

#### SAMPLE/PRELOAD

SAMPLE/PRELOAD is a Standard 1149.1 mandatory public instruction. When the SAMPLe/PRELOAD instruction is loaded in the Instruction Register, moving the TAP controller into the Capture-DR state loads the data in the RAMs input and I/O buffers into the Boundary Scan Register. Because the RAM clock is independent from the TAP Clock (TCK) it is possible for the TAP to attempt to capture the I/O ring contents while the input buffers are in transition (i.e. in a metastable state). Although allowing the TAP to sample metastable inputs will not harm the device, repeatable results cannot be expected. RAM input signals must be stabilized for long enough to meet the TAPs input data capture set-up plus hold time (t<sub>TS</sub> plus t<sub>TH</sub>). The RAMs clock inputs need not be paused for any other TAP operation except capturing the I/O ring contents into the Boundary Scan Register. Moving the controller to Shift-DR state then places the boundary scan register between the TDI and TDO pins. Because the PRELOAD portion of the command is not implemented in this device, moving the controller to the Update-DR state with the SAMPLe / PRELOAD instruction loaded in the Instruction Register has the same effect as the Pause-DR command. This functionality is not Standard 1149.1-compliant.

#### EXTEST

EXTEST is an IEEE 1149.1 mandatory public instruction. It is to be executed whenever the instruction register, whatever length it may be in the device, is loaded with all logic 0s. EXTEST is not implemented in this device. Therefore, this device is not 1149.1-compliant. Nevertheless, this RAM's TAP does respond to an all zeros instruction, as follows. With the EXTEST (000) instruction loaded in the instruction register the RAM responds just as it does in response to the BYPASS instruction described above.

#### IDCODE

The IDCODE instruction causes the ID ROM to be loaded into the ID register when the controller is in Capture-DR mode and places the ID register between the TDI and TDO pins in Shift-DR mode. The IDCODE instruction is the default instruction loaded in at power up and any time the controller is placed in the Test-Logic-Reset state.

#### SAMPLE-Z

If the SAMPLE-Z instruction is loaded in the instruction register, all RAM outputs are forced to an inactive drive state (high-Z) and the Boundary Scan Register is connected between TDI and TDO when the TAP controller is moved to the Shift-DR state.

#### RFU

These instructions are Reserved for Future Use. In this device they replicate the BYPASS instruction.

#### JTAG TAP Instruction Set Summary

Instruction	Code	Description	Notes
EXTEST	000	Replicates BYPASS instruction. Places Bypass Register between TDI and TDO. This RAM does not implement 1149.1 EXTEST function. *Not 1149.1 Compliant *	1
IDCODE	001	Preloads ID Register and places it between TDI and TDO.	1, 2
SAMPLE-Z	010	Captures I/O ring contents. Places the Boundary Scan Register between TDI and TDO. Forces all RAM output drivers to High-Z.	1
RFU	011	Do not use this instruction; Reserved for Future Use. Replicates BYPASS instruction. Places Bypass Register between TDI and TDO.	1
SAMPLE/ PRELOAD	100	Captures I/O ring contents. Places the Boundary Scan Register between TDI and TDO. This RAM does not implement 1149.1 PRELOAD function. *Not 1149.1 Compliant *	1
GSI	101	GSI private instruction.	1
RFU	110	Do not use this instruction; Reserved for Future Use. Replicates BYPASS instruction. Places Bypass Register between TDI and TDO.	1
BYPASS	111	Places Bypass Register between TDI and TDO.	1

#### Notes:

1. Instruction codes expressed in binary, MSB on left, LSB on right.
2. Default instruction automatically loaded at power-up and in test-logic-reset state.

### JTAG Port Recommended Operating Conditions and DC Characteristics

Parameter	Symbol	Min.	Max.	Unit	Notes
Test Port Input High Voltage	$V_{IHT}$	1.7	$V_{DD} + 0.3$	V	1, 2
Test Port Input Low Voltage	$V_{ILT}$	-0.3	0.8	V	1, 2
TMS, TCK and TDI Input Leakage Current	$I_{INTH}$	-300	1	uA	3
TMS, TCK and TDI Input Leakage Current	$I_{INTL}$	-1	1	uA	4
TDO Output Leakage Current	$I_{OLT}$	-1	1	uA	5
Test Port Output High Voltage	$V_{OHT}$	2.4	—	V	6, 7
Test Port Output Low Voltage	$V_{OLT}$	—	0.4	V	6, 8

**Notes:**

1. This device features input buffers compatible with both 3.3 V and 2.5 V I/O drivers.
2. Input Under/overshoot voltage must be  $-2\text{ V} > V_i < V_{DD} + 2\text{ V}$  with a pulse width not to exceed 20%  $t_{TKC}$ .
3.  $V_{DD} \geq V_{IN} \geq V_{IL}$
4.  $0\text{ V} \leq V_{IN} \leq V_{IL}$
5. Output Disable,  $V_{OUT} = 0$  to  $V_{DD}$
6. The TDO output driver is served by the  $V_{DD}$  supply.
7.  $I_{OH} = -4\text{ mA}$
8.  $I_{OL} = +4\text{ mA}$

### JTAG Port AC Test Conditions

Parameter	Conditions
Input high level	2.3 V
Input low level	0.2 V
Input slew rate	1 V/ns
Input reference level	1.25 V
Output reference level	1.25 V

**Notes:**

1. Include scope and jig capacitance.

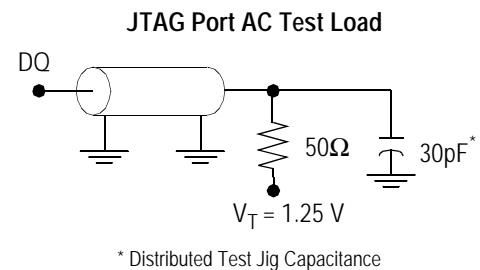

### JTAG Port Timing Diagram

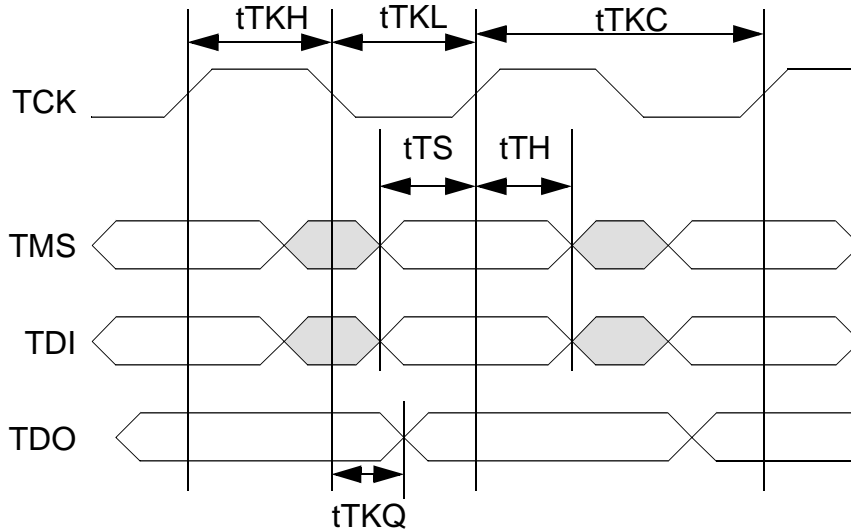

### JTAG Port AC Electrical Characteristics

Parameter	Symbol	Min	Max	Unit
TCK Cycle Time	$t_{TKC}$	20	—	ns
TCK Low to TDO Valid	$t_{TKQ}$	—	10	ns
TCK High Pulse Width	$t_{TKH}$	10	—	ns
TCK Low Pulse Width	$t_{TKL}$	10	—	ns
TDI & TMS Set Up Time	$t_{TS}$	5	—	ns
TDI & TMS Hold Time	$t_{TH}$	5	—	ns

## GS88118/36T TQFP Boundary Scan Register

Order	x36	x18	Pin
1	PH = 0		n/a
2	PH = 0		n/a
3	A10		44
4	A11		45
5	A12		46
6	A13		47
7	A14		48
8	A15		49
9	A16		50
10	x36 = DQA9	NC = 1	51
11	DQA8	NC = 1	52
12	DQA7	NC = 1	53
13	DQA6	NC = 1	56
14	DQA5	NC = 1	57
15	DQA4	DQA1	58
16	DQA3	DQA2	59
17	DQA2	DQA3	62
18	DQA1	DQA4	63
19	ZZ		64
20	QE		66
21	DQB1	DQA5	68
22	DQB2	DQA6	69
23	DQB3	DQA7	72
24	DQB4	DQA8	73
25	DQB5	DQA9	74
26	DQB6	NC = 1	75
27	DQB7	NC = 1	78
28	DQB8	NC = 1	79
29	x36 = DQB9	A18	80

Order	x36	x18	Pin
30	A9		81
31	A8		82
32	ADV		83
33	ADSP		84
34	ADSC		85
35	G		86
36	BW		87
37	GW		88
38	CK		89
39	PH = 0		n/a
40	PH = 0		n/a
41	A17		92
42	BA		93
43	BB		94
44	Bc	NC = 1	95
45	Bd	NC = 1	96
46	E2		97
47	E1		98
48	A7		99
49	A6		100
50	x36 = DQC9	NC = 1	1
51	DQC8	NC = 1	2
52	DQC7	NC = 1	3
53	DQC6	NC = 1	6
54	DQC5	NC = 1	7
55	DQC4	DQB1	8
56	DQC3	DQB2	9
57	DQC2	DQB3	12
58	DQC1	DQB4	13

Order	x36	x18	Pin
59	FT		14
60	DP		16
61	PH = 1		n/a
62	DQD1	DQB5	18
63	DQD2	DQB6	19
64	DQD3	DQB7	22
65	DQD4	DQB8	23
66	DQD5	DQB9	24
67	DQD6	NC = 1	25
68	DQD7	NC = 1	28
69	DQD8	NC = 1	29
70	x36 = DQD9	NC = 1	30
71	LBO		31
72	A5		32
73	A4		33
74	A3		34
75	A2		35
76	A1		36
77	A0		37
78	PH = 0		n/a

BPR 1999.08.11

Notes:

1. The Boundary Scan Register contains a number of registers that are not connected to any pin. They default to the value shown at reset.
2. Registers are listed in exit order (i.e. Location 1 is the first out of the TDO pin).
3. NC = No Connect, NA = Not Active, PH = Place Holder (No associated pin)

## Output Driver Characteristics

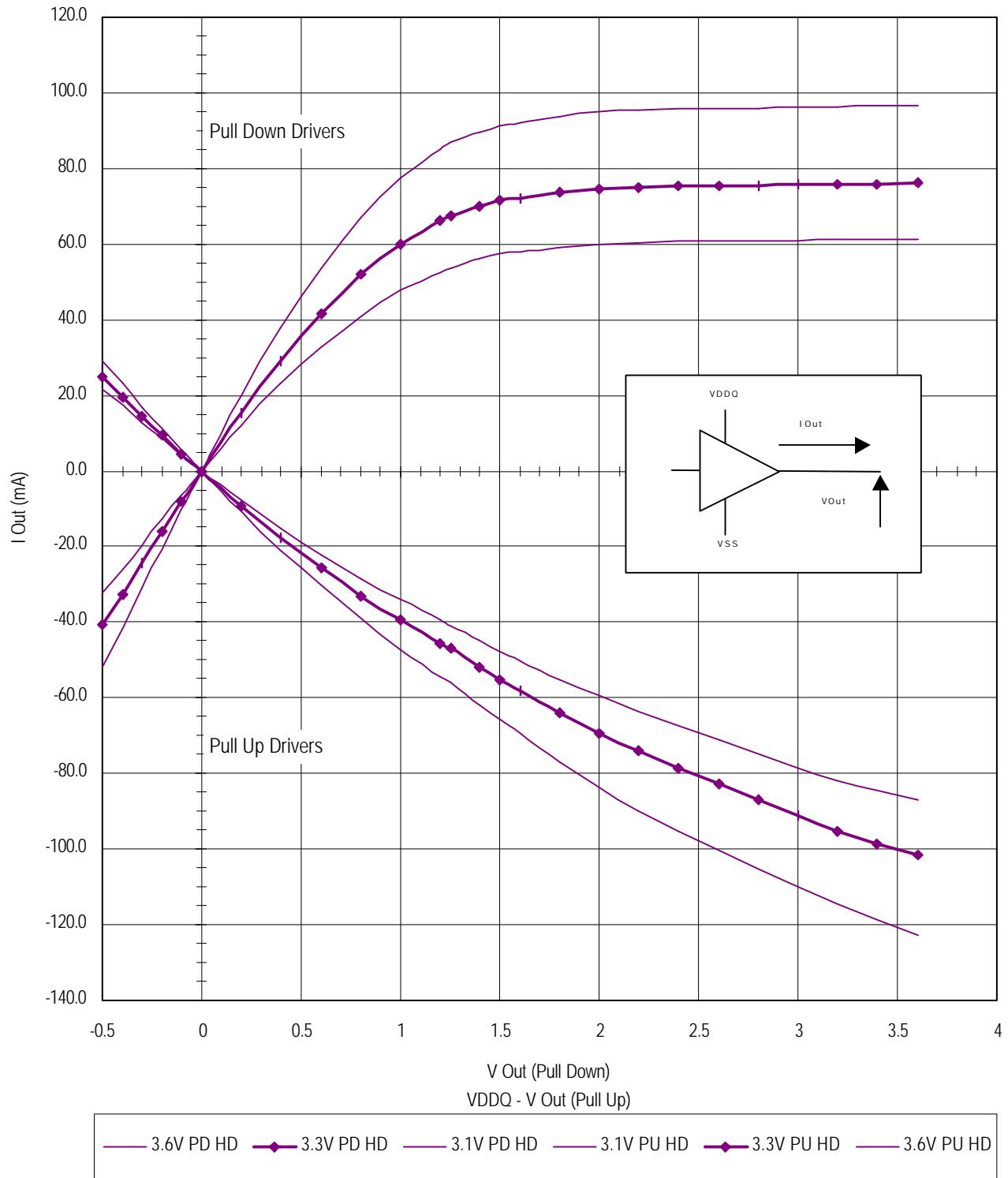

BPR 1999.05.18

### TQFP Package Drawing

Symbol	Description	Min.	Nom.	Max
A1	Standoff	0.05	0.10	0.15
A2	Body Thickness	1.35	1.40	1.45
b	Lead Width	0.20	0.30	0.40
c	Lead Thickness	0.09	—	0.20
D	Terminal Dimension	21.9	22.0	22.1
D1	Package Body	19.9	20.0	20.1
E	Terminal Dimension	15.9	16.0	16.1
E1	Package Body	13.9	14.0	14.1
e	Lead Pitch	—	0.65	—
L	Foot Length	0.45	0.60	0.75
L1	Lead Length	—	1.00	—
Y	Coplanarity	—	—	0.10
$\theta$	Lead Angle	0°	—	7°

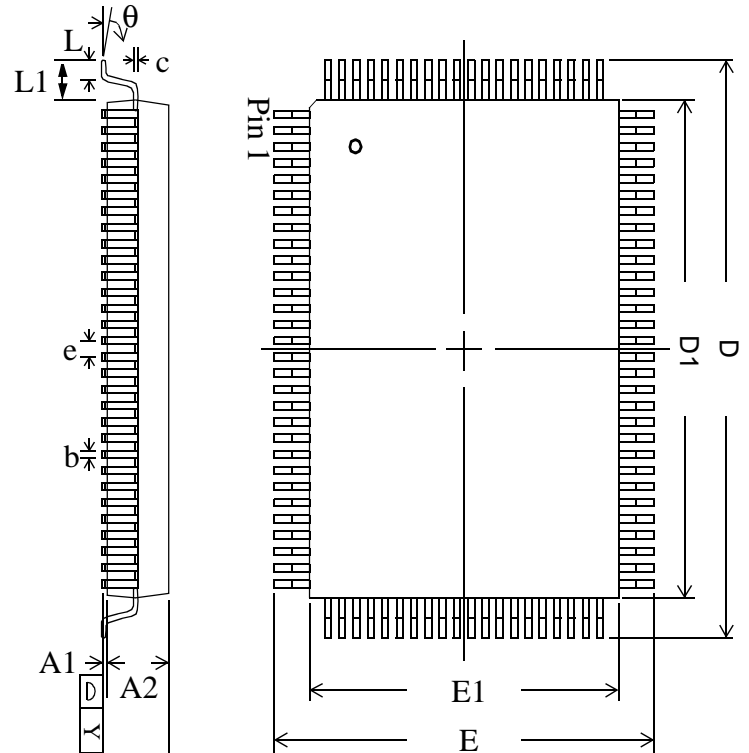

**Notes:**

1. All dimensions are in millimeters (mm).
2. Package width and length do not include mold protrusion.

BPR 1999.05.18

### Ordering Information for GSI Synchronous Burst RAMs

Org	Part Number <sup>1</sup>	Type	Package	Speed <sup>2</sup> (MHz/ns)	T <sub>A</sub> <sup>3</sup>	Status
514K x 18	GS88118T-11	ByteSafe Pipeline/Flow Through	TQFP	100/11	C	
514K x 18	GS88118T-11.5	ByteSafe Pipeline/Flow Through	TQFP	100/11.5	C	
514K x 18	GS88118T-100	ByteSafe Pipeline/Flow Through	TQFP	100/12	C	
514K x 18	GS88118T-80	ByteSafe Pipeline/Flow Through	TQFP	80/14	C	
514K x 18	GS88118T-66	ByteSafe Pipeline/Flow Through	TQFP	66/18	C	
256K x 36	GS88136T-11	ByteSafe Pipeline/Flow Through	TQFP	100/11	C	
256K x 36	GS88136T-11.5	ByteSafe Pipeline/Flow Through	TQFP	100/11.5	C	
256K x 36	GS88136T-100	ByteSafe Pipeline/Flow Through	TQFP	100/12	C	
256K x 36	GS88136T-80	ByteSafe Pipeline/Flow Through	TQFP	80/14	C	
256K x 36	GS88136T-66	ByteSafe Pipeline/Flow Through	TQFP	66/18	C	
514K x 18	GS88118T-11I	ByteSafe Pipeline/Flow Through	TQFP	100/11	I	
514K x 18	GS88118T-11.5I	ByteSafe Pipeline/Flow Through	TQFP	100/11.5	I	
514K x 18	GS88118T-100I	ByteSafe Pipeline/Flow Through	TQFP	100/12	I	
514K x 18	GS88118T-80I	ByteSafe Pipeline/Flow Through	TQFP	80/14	I	
514K x 18	GS88118T-66I	ByteSafe Pipeline/Flow Through	TQFP	66/18	I	
256K x 36	GS88136T-11I	ByteSafe Pipeline/Flow Through	TQFP	100/11	I	
256K x 36	GS88136T-11.5I	ByteSafe Pipeline/Flow Through	TQFP	100/11.5	I	
256K x 36	GS88136T-100I	ByteSafe Pipeline/Flow Through	TQFP	100/12	I	
256K x 36	GS88136T-80I	ByteSafe Pipeline/Flow Through	TQFP	80/14	I	
256K x 36	GS88136T-66I	ByteSafe Pipeline/Flow Through	TQFP	66/18	I	

Notes:

- Customers requiring delivery in Tape and Reel should add the character "T" to the end of the part number. Example: GS88118TT.
- The speed column indicates the cycle frequency (MHz) of the device in Pipeline mode and the latency (ns) in Flow Through mode. Each device is Pipeline/Flow Through mode-selectable by the user.
- T<sub>A</sub> = C = Commercial Temperature Range. T<sub>A</sub> = I = Industrial Temperature Range.
- GSI offers other versions this type of device in many different configurations and with a variety of different features, only some of which are covered in this data sheet. See the GSI Technology web site ([www.gsistechnology.com](http://www.gsistechnology.com)) for a complete listing of current offerings.



## Revision History

DS/Date Rev. Code: Old; New	Types of Changes Format or Content	Page;Revisions;Reason
<b>GS88118/36T</b> Rev1.04h 5/ 1999; 1.05 9/1999I	Format/Typos	<ul style="list-style-type: none"> <li>• Last Page/Fixed "GSGS.." in Ordering Information Note.</li> <li>• Formatted Pin Outs and Pin Description to new small caps.</li> <li>• Formatted Block diagrams to new small caps.</li> <li>• Formatted Timing Diagrams to new small caps.</li> <li>• Changed "Flow thru" to "Flow Through" in Timing Diagrams.</li> <li>• Boundary Scan Register/Formatted to new small caps.</li> <li>• Package Diagram/Changed "Dimesion" to "Dimension".</li> </ul>
	Content	<ul style="list-style-type: none"> <li>• 5/Fixed pin description table to match pinouts.</li> <li>• Pin Description/Changed chip enables to match pins.</li> <li>• Pin Description/Changed pin 80 from NC to Address Input.</li> <li>• Pin Description/Rearranged Address Inputs to match order of Pinout</li> <li>• Package Diagram/Changed Dimension D Max from 20.1 to 22.1</li> </ul>
<b>GS88118/36T</b> 1.05 9/ 1999I;1.06 11/1999J	Content	<ul style="list-style-type: none"> <li>• Took out wrong Pinout on page 2 (256K x 32).</li> <li>• First Release of 880 F.</li> </ul>
<b>GS88118/36T</b> 1.06 11/ 1999J;1.06 11/1999K	content	<ul style="list-style-type: none"> <li>• Changed Bump 3C to 4L on first page to correspond SCD pin in BGA pinout.</li> </ul>
<b>GS88118/36T</b> 1.06 11/ 1999K <b>88118/36T</b> 1.07 1/ 2000L	Content	<ul style="list-style-type: none"> <li>• Changed order of TQFP Address Inputs to match pinout.</li> <li>• Changed order of TQFP DATA Input and Output pins to match pinout.</li> <li>• New GSI Logo.</li> </ul>
GS88118/36T1.07 1/2000M; GS88118/36T1.08 3/2000N;	Content	<ul style="list-style-type: none"> <li>• Changed all speed bin information (headings, references, tables, ordering info..) to reflect 150 - 80Mhz</li> </ul>
GS88118/36T1.08 3/2000N; GS88118/36T1.09 3/2000O;	Content	<ul style="list-style-type: none"> <li>• Corrections to AC Electrical Characteristics Table -</li> <li>• Fixed Boundary Scan Register Added Pin 29</li> </ul>
8818 NGS88118/36T1.09 3/ 2000O; 8811836_r1_10	Content/Format	<ul style="list-style-type: none"> <li>• Removed 150 MHz speed bin</li> <li>• Changed 133 MHz and 117 MHz speed bins to 11 ns and 11.5 ns (100 MHz) numbers</li> <li>• Updated format to comply with Technical Publications standards</li> </ul>
88118_r1_10; 88118_r1_11	Content	<ul style="list-style-type: none"> <li>• Updated Capacitance table—removed Input row and changed Output row to I/O</li> </ul>