

## X-Ray CCD Camera C6086 Series



The C6086 series is a compact, lightweight, high resolution X-ray CCD camera. It consists of an X-ray sensitive scintillator (P43) coated on a tapered fiberoptic bundle direct coupled to a CCD camera.

The C6086-90 camera controller incorporates a 10-bit A/D converter for precise image acquisition and is also capable of a number of realtime image processing functions such as averaging, background subtraction and edge enhancement.



▲ Dedicated Control Box A6649 is Optional.

### FEATURES

- High Spatial Resolution
  - 25  $\mu\text{m}$  (C6086-03, 04)
  - 30  $\mu\text{m}$  (C6086-53, 54)
  - 43  $\mu\text{m}$  (C6086-13, 14)
  - 62  $\mu\text{m}$  (C6086-23, 24)
- Effective X-ray tube voltage range  
10 to 100 kVp
- 10-bit A/D converter
- Contrast Enhancement
- Real Time Image Processing

# SPECIFICATIONS

## • Camera head

Type. number	C6086-03	C6086-04	C6086-13	C6086-14	C6086-23	C6086-24	C6086-53	C6086-54
Material of X-ray scintillator	P43 (GdO <sub>2</sub> S:Tb)( Window material : Aluminum )							
Effective X-ray tube voltage range (kVp)	10 to 100							
Spatial resolution (μm)	25		43		62		30	
Effective field of view (mm <sup>2</sup> )	8.8 × 6.5	8.6 × 6.4	19.9 × 14.9	19.5 × 14.6	32.4 × 24.2	31.6 × 23.8	12.7 × 9.5	12.4 × 9.3
Fiber type	Straight fiber		2.27:1 tapered fiber		3.69:1 tapered fiber		1.45:1 tapered fiber	
Imaging device	Interline-type CCD							
Video system	EIA	CCIR	EIA	CCIR	EIA	CCIR	EIA	CCIR
Video output	1.0Vp-p 75Ω terminated							
Power requirements / consumption	DC +12 V (12P) / 1.6 W							

## • Camera Controller C6086-90

A/D converter	10-bit
Frame memory	16-bit memory × 2 planes
Digital interface	SCSI II (optional)
Image processing functions	Gain/Offset, On-chip integration, Image accumulation, Recursive average, Zoom, Background subtraction, Edge enhancement mask (selectable)
Operating / Storage temperature	0°C to 40 °C / -10 °C to 40 °C
Operating / Storage humidity	Less than 70% (no condensation)
Line voltage / Power consumption	AC 100V, 117V, 220V, 240V ±10% 50/60Hz / Approx. 60VA

# DIMENSIONAL OUTLINE (UNIT:mm)

## • Camera head

**C6086-03,04** (Weight : Approx. 0.4 kg)

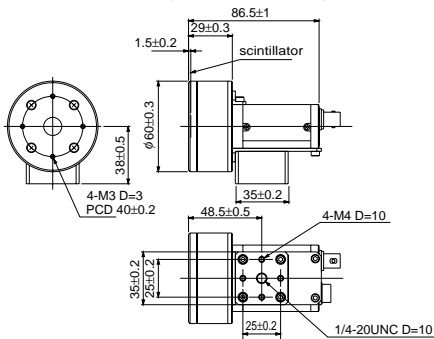

**C6086-13,14** (Weight : Approx. 0.6 kg)

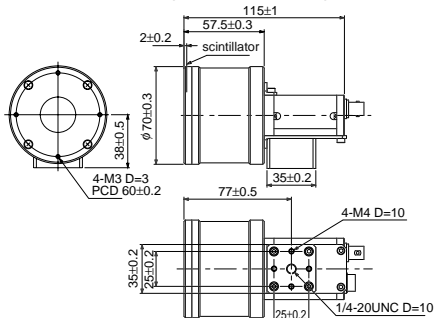

**C6086-23,24** (Weight : Approx. 0.7 kg)

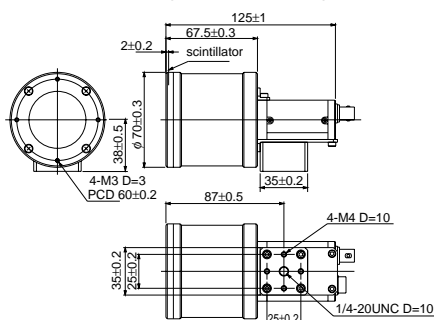

**C6086-53,54** (Weight : Approx. 0.5 kg)

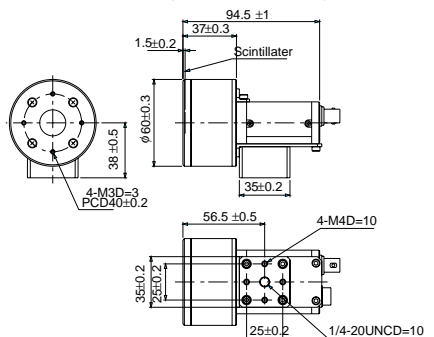

## • Control Box A6649

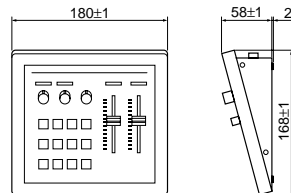

(Weight : Approx. 0.9 kg)

## • Camera Controller

**C6086-90** (Weight : Approx. 5.0 kg)

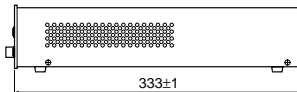
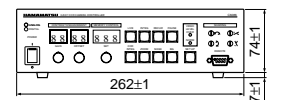

★ Product and software package names noted in this documentation are trademarks or registered trademarks of their respective manufacturers.

- Subject to local technical requirements and regulations, availability of products included in this promotional material may vary. Please consult with our sales office.
- Information furnished by HAMAMATSU is believed to be reliable. However, no responsibility is assumed for possible inaccuracies or omissions. Specifications and external appearance are subject to change without notice.

© 2001Hamamatsu Photonics K.K.

# HAMAMATSU

Homepage Address <http://www.hamamatsu.com>

HAMAMATSU PHOTONICS K.K., Systems Division

812 Joko-cho, Hamamatsu City, 431-3196, Japan, Telephone: (81)53-431-0124, Fax: (81)53-435-1574, E-mail: [export@sys.hpk.co.jp](mailto:export@sys.hpk.co.jp)

U.S.A. and Canada: Hamamatsu Photonic Systems: 360 Foothill Road, Bridgewater, N.J. 08807-0910, U.S.A., Telephone: (1)908-231-1116, Fax: (1)908-231-0852, E-mail: [usa@hamamatsu.com](mailto:usa@hamamatsu.com)

Germany: Hamamatsu Photonics Deutschland GmbH: Arzbergerstr. 10, D-82211 Herrsching am Ammersee, Germany, Telephone: (49)8152-375-0, Fax: (49)8152-2658, E-mail: [info@hamamatsu.de](mailto:info@hamamatsu.de)

France: Hamamatsu Photonics France S.A.R.L.: 8, Rue du Saule Trapu, Parc du Moulin de Massy, 91882 Massy Cedex, France, Telephone: (33)1 69 53 71 00, Fax: (33)1 69 53 71 10, E-mail: [infos@hamamatsu.fr](mailto:infos@hamamatsu.fr)

United Kingdom: Hamamatsu Photonics UK Limited: 2 Howard Court, Welwyn Garden City, Hertfordshire, AL7 1BW, U.K., Telephone: (44) 1707-294888, Fax: (44) 1707-325777, E-mail: [info@hamamatsu.co.uk](mailto:info@hamamatsu.co.uk)

North Europe: Hamamatsu Photonics Norden AB: Smidsvägen 12, SE-171-41 Solna, Sweden, Telephone: (46)8-509-031-00, Fax: (46)8-509-031-01, E-mail: [info@hamamatsu.se](mailto:info@hamamatsu.se)

Italy: Hamamatsu Photonics Italia S.R.L.: Strada della Moia, 1/E 20020 Arese (Milano), Italy, Telephone: (39)02-935 81 733, Fax: (39)02-935 81 741, E-mail: [info@hamamatsu.it](mailto:info@hamamatsu.it)

Cat. No. SICS1042E07

SEP/2001 HPK

Created in Japan (PDF)