

A microchannel plate (MCP) is a secondary-electron multiplier which detects and amplifies electrons in two-dimensions. The MCP is sensitive not only to electrons but to ions, vacuum ultraviolet light, X-rays and γ -rays, making it useful in a wide range of detection applications.

Hamamatsu has available seven types of circular MCPs, ranging in outer diameter from 18mm to 114mm. MCP assemblies with electrode leads are also available to facilitate use of the MCPs. These MCP assemblies offer three types of read-out devices; a phosphor screen (optical image conversion), a multi-anode (electrical output signals responding to the position of the incident signals), and a single-anode (an electrical output signal within the effective area), providing a variety of readout functions to handle a range of applications. From one to three MCPs can be selected as required to provide the necessary electron gain.

These MCPs and MCP assemblies are finding wide application in fields including image intensifiers, fast time response photomultiplier tubes, and analytical instruments.

FEATURES

- Sensitive to electrons, ions, VUV lights, X-rays and γ -rays
- Two-dimensional image intensification
- Fast time response
- Immunity to magnetic fields
- Small size and lightweight

APPLICATIONS

- Analytical Instruments
 - Electron Beam Measuring System (EBMS)
 - FIM, AP-FIM
 - ESCA
 - Mass Spectrometer (MS)
 - TOF-MS
 - LEED, MEED, etc.
- Electron Tube
 - Image Intensifier
 - Fast Time Response PMT
 - Streak Camera
- Cosmic Measurement
 - Detection of Plasma Ions, Soft X-rays and VUV lights
- High Energy Physics
 - Detection of Ions, Electrons, Positrons, High Energy Particles and X-rays

CIRCULAR MCP SERIES

MCP DIMENSIONAL OUTLINES (Unit: mm)

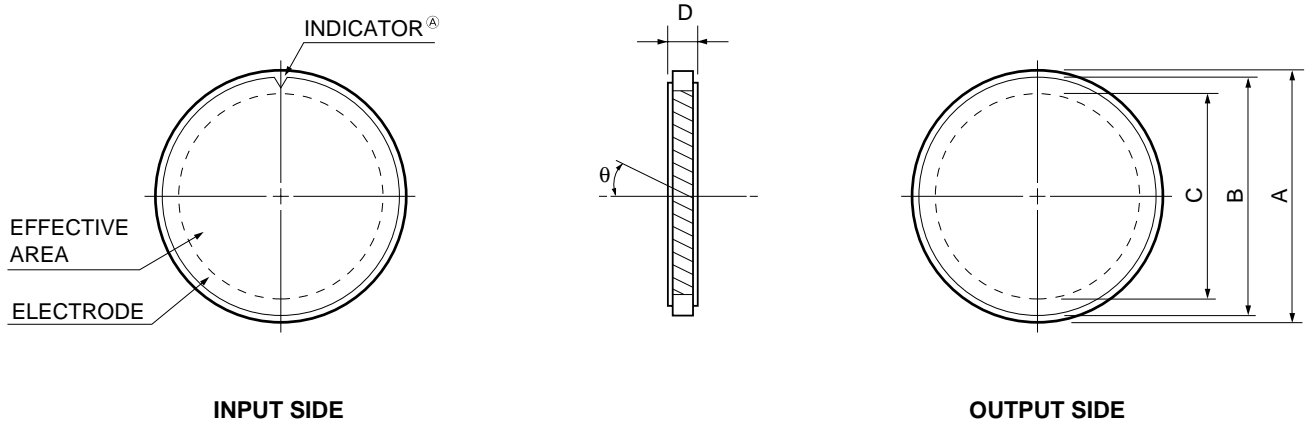

TMCPA0025EB

Parameter	Type No.	F1551			F1094			F1552		F1208	F1217	F1942	F2395		Unit
		-01	-07	-09	-01	-09	-01			-01		-04			
Outer Diameter	A	17.9	24.8			32.8		38.5	49.9	86.7	114			mm	
Electrode Diameter	B	17	23.9			31.8		36.5	49	84.7	112			mm	
Effective Diameter	C	14.5	20			27		32	42	77	105			mm	
Thickness	D	0.48	0.24	0.41	0.48	0.41	0.48	0.48		1.00				mm	
Channel Diameter		12	6	10	12	10	12	12		25				μm	
Channel Pitch		15	7.5	12	15	12	15	15		31				μm	
Bias Angle	θ	8	13	5,15	5,8,15	8,12		8		8				degrees	
Open Area Ratio		60												%	
Electrode Material		Inconel												—	

ELECTRICAL CHARACTERISTICS

(Supply Voltage: 1000V, Vacuum: 1.3×10^{-4} Pa (1×10^{-6} Torr), Ambient Temperature: +25°C)

Gain	More than 10^4							—
Plate Resistance	100 to 700	50 to 500	30 to 300	20 to 200	10 to 200	10 to 100	5 to 50	MΩ
Dark Current	Less than 5×10^{-13}							A/cm ³
Max. Linear Output Signal	Up to 7% of the strip current [ⓑ]							—

MAXIMUM RATINGS

Supply Voltage [ⓒ]	1000 (Channel Diameter: 6μm, 10μm, 12μm): 1200 (Channel Diameter: 25μm)	V
Ambient Temperature	-50 to +70	-50 to +30 °C
Baking Temperature	400	°C

Ⓐ This indicator shows the MCP input side and the direction of channel bias.

Ⓑ The strip current is the current which flows along the channel wall when a voltage is applied between the MCP input and output and is given by applied voltage/plate resistance.

Ⓒ At a vacuum of 1.3×10^{-4} Pa (1×10^{-6} Torr) or less.

Consult us for more details on MCP dimensions and tolerances.

OPERATING PRINCIPLE

As shown in the figure, when a voltage V_D is applied across the input-side and output-side electrodes of the MCP, a potential gradient is built up along the channel direction. If an incident electron strikes an inner wall on the input side, a number of secondary electrons are emitted. These secondary electrons are accelerated by the potential gradient and travel along a parabolic path determined by the initial velocity. They then collide with the opposing wall surface, causing secondary electrons to be emitted again. In this manner, the electrons collide repeatedly within the channel as they pass towards the output side. The result is a large multiplication of the incident electron.

MCP CONFIGURATION

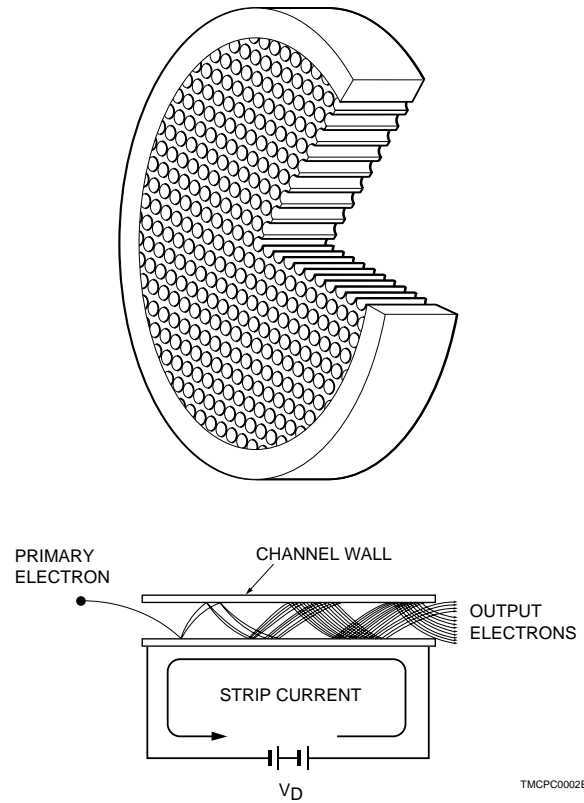

TMCP0002EC

GAIN AND LIFE CHARACTERISTICS

• Gain vs. Supply Voltage

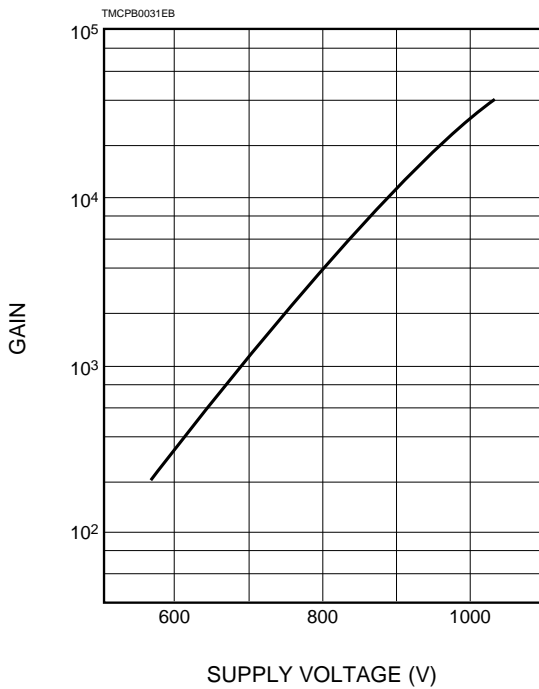

• Life

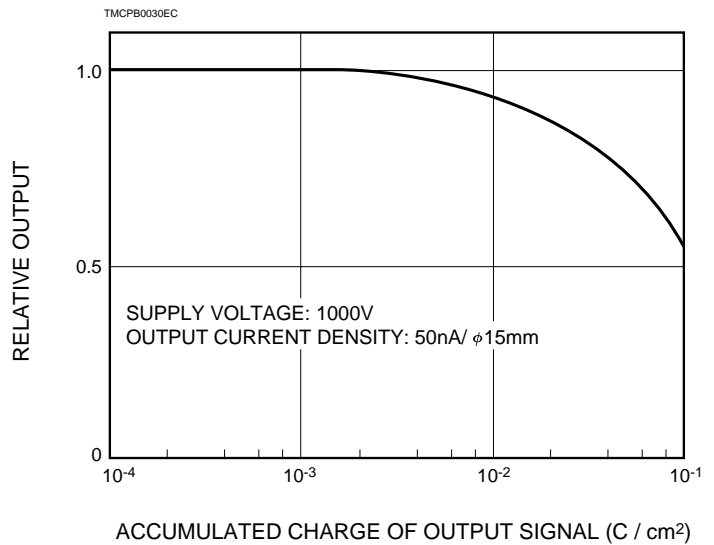

MCP ASSEMBLIES

Demountable Type Series (The MCP and the Read-Out Device Can be Easily Replaced)

ASSEMBLY DIMENSIONS (Unit: mm)

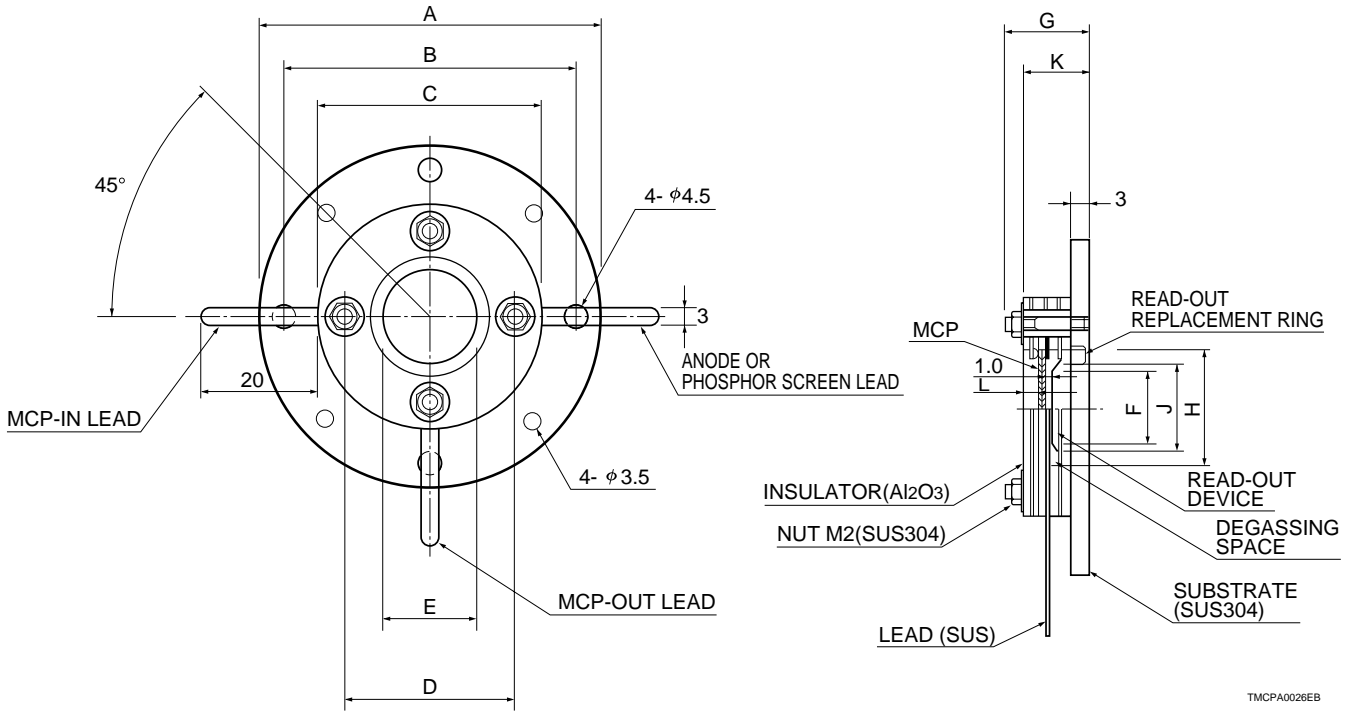

TMCPA0026EB

Note: SUS and SUS304 are stainless steels of Japanese Industrial Standards (JIS) code.

Code	Parameter	F2221	F2222	F2223	F2224	F2225	F2226	Unit	
A	Assembly Outer Diameter	φ 54	φ 61	φ 69	φ 75	φ 86	φ 123	mm	
B	Mounting Screw Hole Pitch	φ 46	φ 53	φ 61	φ 67	φ 78	φ 115	mm	
C	Insulator Outer Diameter	φ 34	φ 41	φ 49	φ 55	φ 66	φ 103	mm	
D	Assembly Screw Pitch	φ 26	φ 33	φ 41	φ 47	φ 58	φ 95	mm	
E	MCP Effective Diameter	φ 14.5	φ 20	φ 27	φ 32	φ 42	φ 77	mm	
F	Readout Device Effective Diameter	φ 10	φ 17	φ 24	φ 30	φ 40	φ 75	mm	
G	Maximum Height	15	15	15	15	15	17	mm	
H	Replacement Ring Screw Diameter for Readout Device	M19	M26	M33.8	M39.5	M51	M88	—	
J	Replacement Ring Inside Diameter for Readout Device	φ 13	φ 20	φ 27	φ 33	φ 44	φ 78	mm	
K	Distance from Bottom of Substrate to Insulator Surface	(Number of MCP stages)							—
		Single-stage: 10.9					12.9		mm
		Two-stage : 11.9					14.4		mm
		Three-stage : 11.9					15.9		mm
L	Distance from MCP Input Surface to Insulator Surface	(Number of MCP stages)		(Channel diameter)					—
				10μm	12μm	25μm			—
		Single-stage:		2.9	2.8	3.8			mm
		Two-stage :		3.5	3.3	4.3			mm
Three-stage :		3.1	2.9	4.8			mm		

Non-Demountable Type Series (Compact and Lightweight)

ASSEMBLY DIMENSIONS (Unit: mm)

WITHOUT ANODE

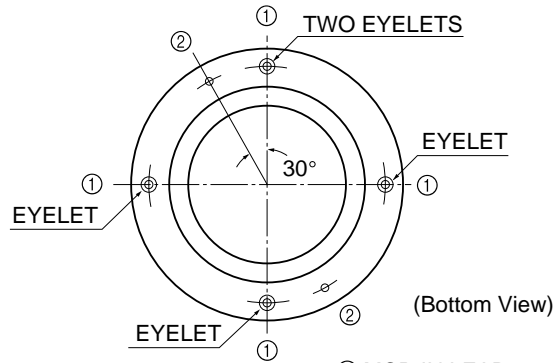
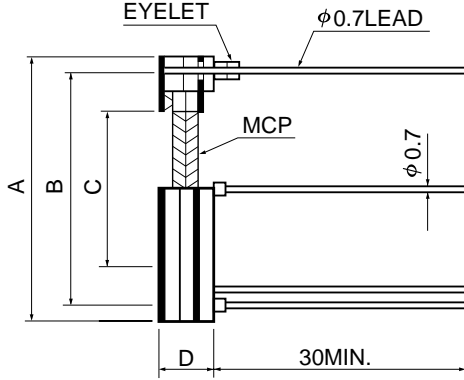

- ① MCP-IN LEAD: 4pcs.
- ② MCP-OUT LEAD: 2pcs.

WITH ANODE

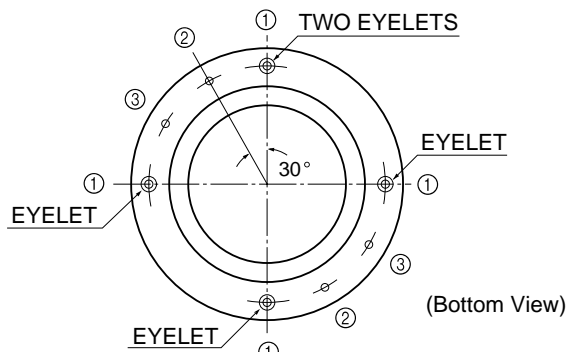
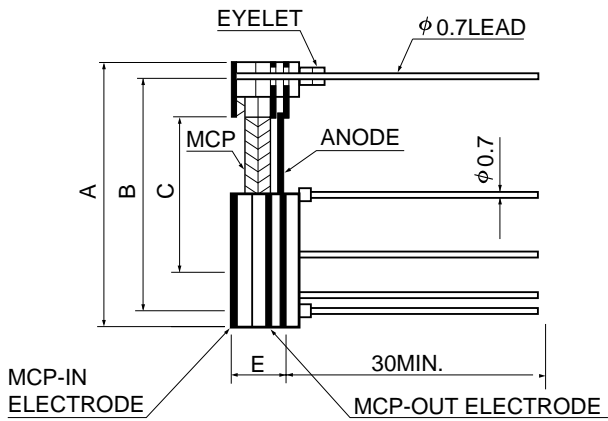

- ① MCP-IN LEAD: 4pcs.
- ② MCP-OUT LEAD: 2pcs.
- ③ ANODE LEAD: 2pcs.

TMCPA0027EB

Type No.		F1551	F1094	F1552	F1208	F1217	Unit
Parameter							
Assembly Outer Diameter	A	$\phi 27$	$\phi 34$	$\phi 42$	$\phi 49$	$\phi 62$	mm
Lead Pin Circle	B	$\phi 22.5$	$\phi 29.5$	$\phi 37.5$	$\phi 44$	$\phi 56$	mm
MCP Effective Diameter	C	$\phi 14.5$	$\phi 20$	$\phi 27$	$\phi 32$	$\phi 40$	mm
Assembly Height	D without anode	(Number of MCP stages) Single-stage: 3 Two-stage : 4.2 Three-stage : 4.2					mm
	E with anode	(Number of MCP stages) Single-stage: 4.5 Two-stage : 5.7 Three-stage : 5.7					mm

MCP ASSEMBLIES

Characteristics of MCP Assemblies

• Typical Gain and Pulse Height Distribution Characteristics Comparison for Different Stage MCP

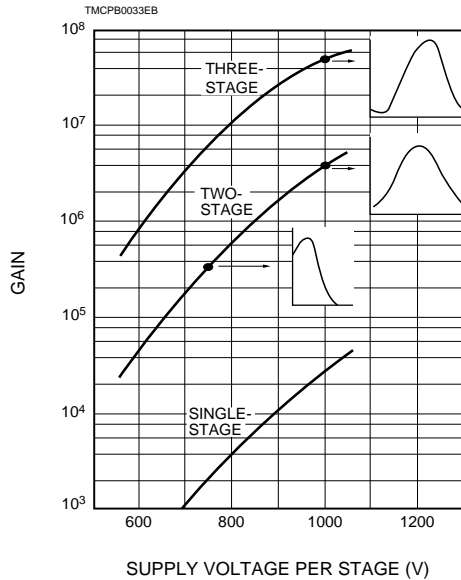

• Typical Pulse Height Distributions for Two- and Three-Stage MCP

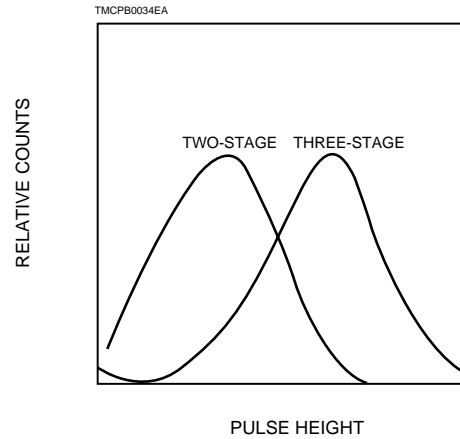

GENERAL

Parameter	MCP	Single-Stage	Two-Stage	Three-Stage
Channel Diameter	(μm)	10 to 25 (Refer to the table on page 2.)		
Read-Out Device		Without read-out device, with single anode, multianode or phosphor screen (P-11, P-20, P-47) ^(A)		

(A) The phosphor screen read-out type is not available for non-demountable type or three-stage series.

ELECTRICAL CHARACTERISTICS

(Supply Voltage: 1000V per stage, Vacuum: In the order of 1.3×10^{-5} Pa (1×10^{-7} Torr), Ambient Temperature: +25°C)

Gain		10^4	10^6	10^7 to 10^8
Dark Noise		Less than 5×10^{-13} A/cm ²	Less than $3 \text{ s}^{-1}/\text{cm}^2$ (cps/cm ²) ^(B)	Less than $3 \text{ s}^{-1}/\text{cm}^2$ (cps/cm ²) ^(B)
Pulse Height Resolution	(%)	—	Less than 120	Less than 80
Max. Linear Output Signal		Up to 7% of the strip current		

(B) Dark noise lower than the valley of pulse height distribution for the signal is not taken into account.

MAXIMUM RATINGS^(C)

MCP Supply Voltage	(V)	1000	2000	3000
MCP-OUT — Anode Voltage	(V)		1000	
MCP-OUT — Phosphor Screen Voltage	(V)		4000	
Substrate — Other Terminals Voltage	(V)		7000	
Baking Temperature	(°C)		350	

(C) At a vacuum of 1.3×10^{-5} Pa (1×10^{-7} Torr) and an ambient temperature of +25°C.

The phosphor screen read-out type assemblies should be operated in a vacuum below 2.6×10^{-5} Pa (2×10^{-7} Torr).

PHOSPHOR SCREEN EMISSION CHARACTERISTICS

Parameter	Phosphor type	P-11	P-20	P-47
Wavelength at Peak Emission	(nm)	450	530 to 560	410
Decay Time <10%>	(μs)	460	50 to 2000	0.08

• Pulse Height Resolution

The pulse height resolution is defined as follows.

$$\text{Pulse Height Resolution} = \frac{\text{FWHM (Full Width at Half Maximum)}}{\text{Pulse Height Peak: A}} \times 100 (\%)$$

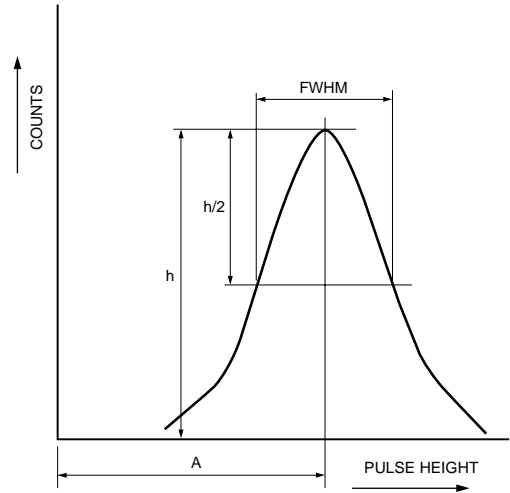

TMCPB0035EA

WIRING EXAMPLES

(For assembly types, either MCP-IN, MCP-OUT, anode or phosphor screen can be ground potential)

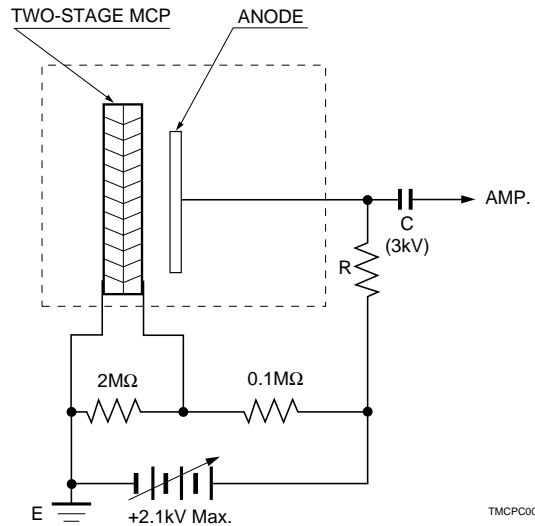
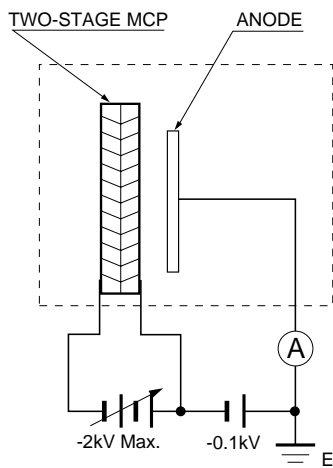

TMCPC0005EC

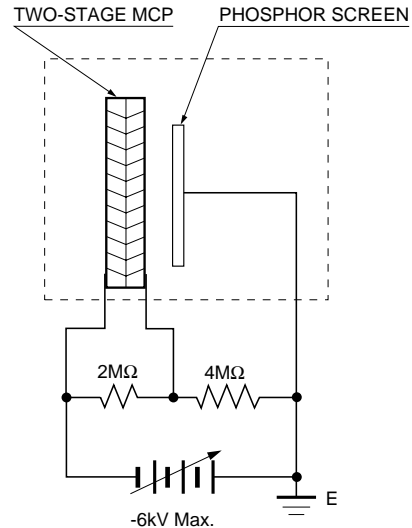
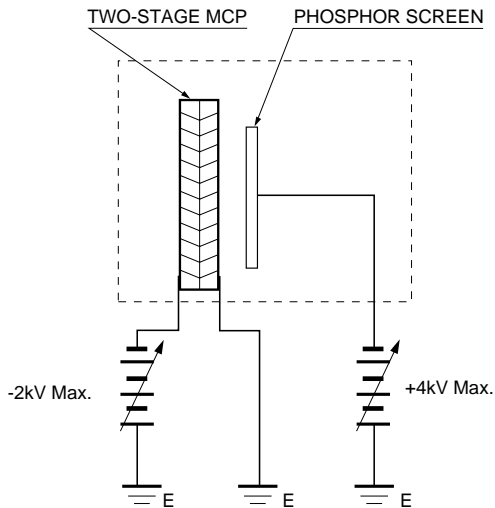

TMCPC0007EC

CIRCULAR MCP AND ASSEMBLY SERIES

ORDERING INFORMATION (Type No. Designation)

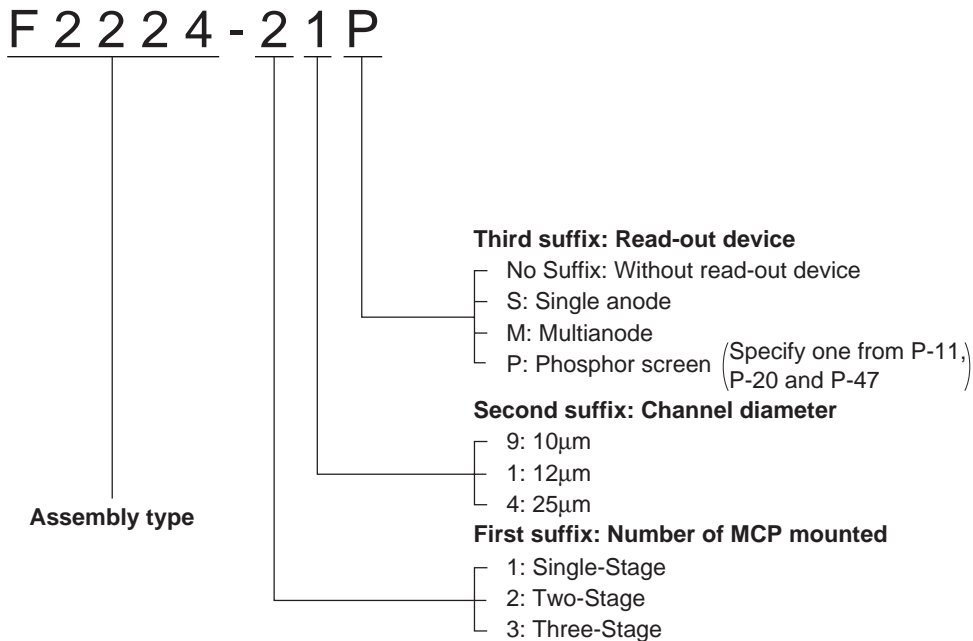

Note: In ordering the MCP only, specify only the type No. of MCP

SPECIAL MCPs AND ASSEMBLIES

- Hamamatsu accepts order for special MCPs not included in the standard line. Please specify the shape, effective dimensions, thickness and the other parameters.
- Feel free to consult us on MCPs with an aperture (for use with reflecting electron microscopes), CsI coating (to increase quantum efficiency in the VUV to X-ray range), aluminum coating (to prevent ion feedback), MgO coating (to obtain high gain) and other special type MCPs.
- For multianode types, specify the desired anode pattern.
- Assemblies with a phosphor-coated fiber plate are available to enable fiber coupling to solid state imaging devices (CCD and MOS Linear Image Sensor) and position sensitive detectors (PSD).
- Assemblies with the MCP, read-out device and terminals mounted on vacuum flanges are also available.

PRECAUTIONS FOR USE

- Avoid touching the MCP or its assembly parts with bare hands.
- Handle the MCP only in a clean room since dust and humidity may adversely affect MCP characteristics.
- The MCP should be kept in vacuum or nitrogen atmosphere if a long period of storage is contemplated.
- When outgassing from the MCP occurs, baking the MCP at 350°C maximum in an evacuating system is recommended. In addition electron bombarding may be effective.
- The MCP should be operated in vacuum below 1.3×10^{-4} Pa (1×10^{-6} Torr).

HAMAMATSU

HOME PAGE URL <http://www.hamamatsu.com>

HAMAMATSU PHOTONICS K.K., Electron Tube Center

314-5, Shimokanzo, Toyooka-village, Iwata-gun, Shizuoka-ken, 438-0193, Japan, Telephone: (81)539/62-5248, Fax: (81)539/62-2205

U.S.A.: Hamamatsu Corporation: 360 Foothill Road, P. O. Box 6910, Bridgewater, N.J. 08807-0910, U.S.A., Telephone: (1)908-231-0960, Fax: (1)908-231-1218

Germany: Hamamatsu Photonics Deutschland GmbH: Arzbergerstr. 10, D-82211 Herrsching am Ammersee, Germany, Telephone: (49)8152-375-0, Fax: (49)8152-2658

France: Hamamatsu Photonics France S.A.R.L.: 8, Rue du Saule Trapu, Parc du Moulin de Massy, 91882 Massy Cedex, France, Telephone: (33)1 69 53 71 00, Fax: (33)1 69 53 71 10

United Kingdom: Hamamatsu Photonics UK Limited: Lough Point, 2 Gladbeck Way, Windmill Hill, Enfield, Middlesex EN2 7JA, United Kingdom, Telephone: 44(20)8-367-3560, Fax: 44(20)8-367-6384

North Europe: Hamamatsu Photonics Norden AB: Smidesvägen 12, SE-171-41 SOLNA, Sweden, Telephone: (46)8-509-031-00, Fax: (46)8-509-031-01

Italy: Hamamatsu Photonics Italia: S.R.L.: Strada della Moia, 1/E, 20020 Arese, (Milano), Italy, Telephone: (39)02-935 81 733, Fax: (39)02-935 81 741

TMCP1007E04
DEC. 1999 IP
Printed in Japan (500)