

LOW-LIGHT-LEVEL MEASUREMENT OF NIR

NIR (NEAR INFRARED:1.4 μ m/1.7 μ m) PHOTOMULTIPLIER TUBES R5509-43/R5509-73

and EXCLUSIVE COOLERS

OVER VIEW

Hamamatsu near infrared photomultiplier tubes (NIR-PMT) R5509-43 and -73 have photocathodes with extended spectral response ranges to 1.4 μ m or 1.7 μ m where beyond 1.1 μ m have been the limit of conventional photocathodes.

The new structure ensures higher sensitivity measurements with lower noise. The R5509-43 is recommended for detection up to 1.35 μ m, while the R5509-73 is up to 1.7 μ m.



TPMHF0484

FEATURES

- **New structure ensures lower noise.**
- **Using a "low power excitation light" allows high-precision measurement not affected by strong excitation light.**
High gain and low noise improve the detection limit.
- **Flat response from visible to near IR minimize spectral sensitivity correction.**
The spectral response covers a wide range from 300 nm to 1.4 μ m or 1.7 μ m.
- **Photoluminescence from a room temperature sample can be measured.**
High sensitivity enables weak light emission measurement.
- **Time resolved measurement in near IR is realized.**
Fast time response (Rise time: 3 ns).

SPECIFICATIONS

●GENERAL

Parameter		R5509-43	R5509-73	Unit
Spectral Response		300 to 1400	300 to 1700	nm
Photocathode	Material	InP/InGaAsP	InP/InGaAs	—
	Minimum Effective Area	3 × 8		mm
Window	Material	Borosilicate glass		—
Dynode	Secondary Emitting Surface	Cu-BeO		—
	Structure	Line focused		—
	Number of Stage	10		—
Base	21-pin base		—	
Recommended Operating Ambient Temperature		-80		°C

●MAXIMUM RATING (Absolute maximum values)

Parameter		Value	Unit
Supply Voltage	Between Anode and Cathode	1750	V dc
Average Anode Current		2	μ A
Storage Ambient Temperature		-90 to +50	°C
Operating Ambient Temperature		-90 to -70	°C

●CHARACTERISTICS (at -80 °C, Supply voltage: -1500 V dc)

Parameter		R5509-43			R5509-73			Unit
		Min.	Typ.	Max.	Min.	Typ.	Max.	
Cathode Sensitivity	Quantum Efficiency ^(a)	0.48	—	—	0.29	—	—	%
	Radiant ^(a)	5	—	—	3.5	—	—	mA/W
Anode Sensitivity	Radiant ^(a)	1000	—	—	700	—	—	A/W
Gain		2×10^5	1×10^6	—	2×10^5	1×10^6	—	—
Anode Dark Current ^(b)		—	4	10	—	40	100	nA
Anode Dark Counts ^(b)		—	1.6×10^4	—	—	1.6×10^5	—	s ⁻¹
Time Response	Anode Pulse Rise Time	—	3	—	—	3	—	ns
	Electron Transit Time	—	23	—	—	23	—	ns
	Transit Time Spread	—	1.5	—	—	1.5	—	ns

NOTE: ^(a)at 1300 nm (R5509-43), at 1500 nm (R5509-73) ^(b)After 30 minutes' storage in darkness

The dedicated coolers PC176TSCE005 and PC176TSCE006 are shipped after adjusting the voltage divider circuit to provide the optimum voltage distribution ratio that best matches the PMT.

CHARACTERISTICS FIGURES

●Spectral Response

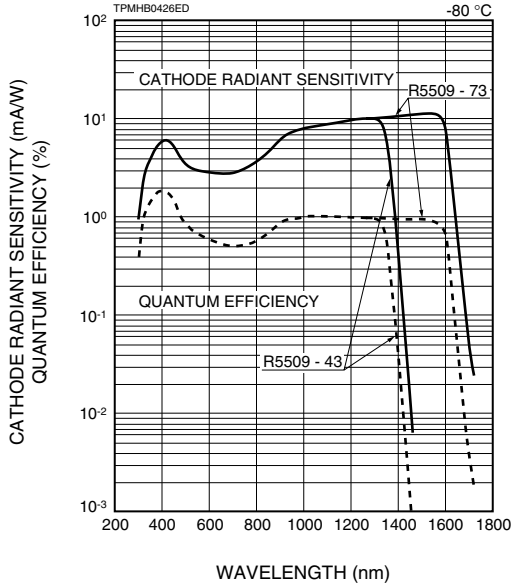

* Spectral response characteristics when used with the dedicated cooler

●Typical Gain (R5509-43, -73)

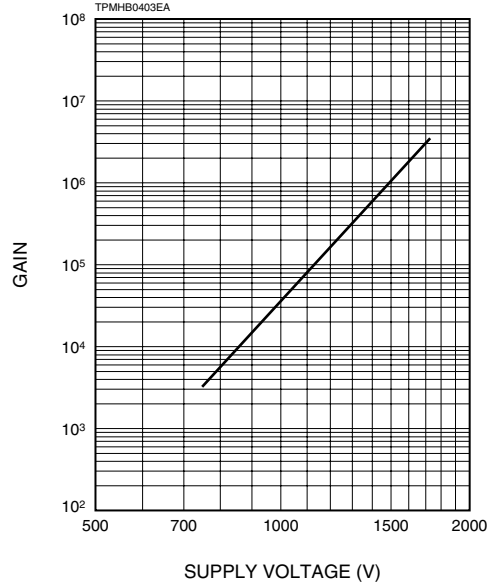

●Temperature Characteristics of Dark Current (After 30 minutes storage in darkness)

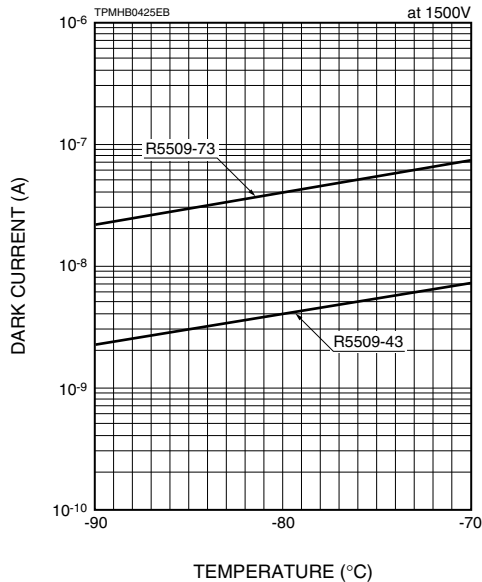

●Output Waveform (R5509-43)

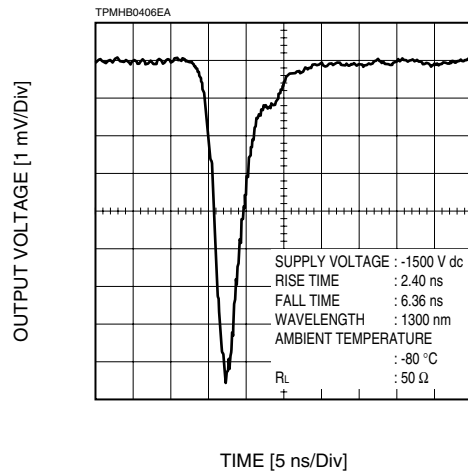

●Single Photoelectron Pulse Height Distribution (PHD)

R5509-43

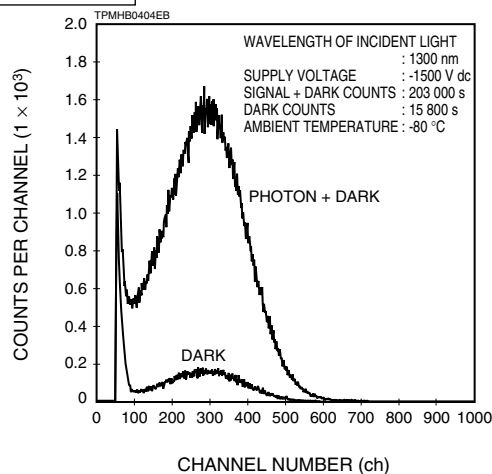

R5509-73

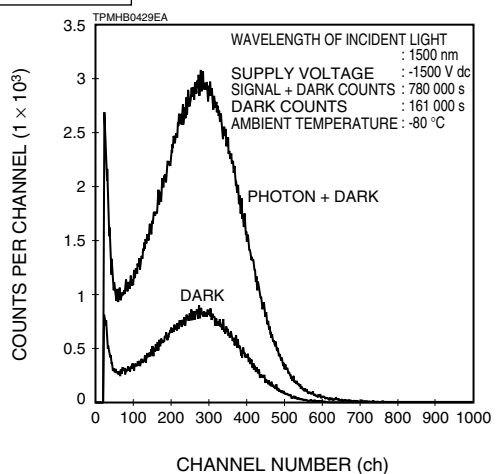

DIMENSIONAL OUTLINE AND BASING DIAGRAM (Unit: mm)

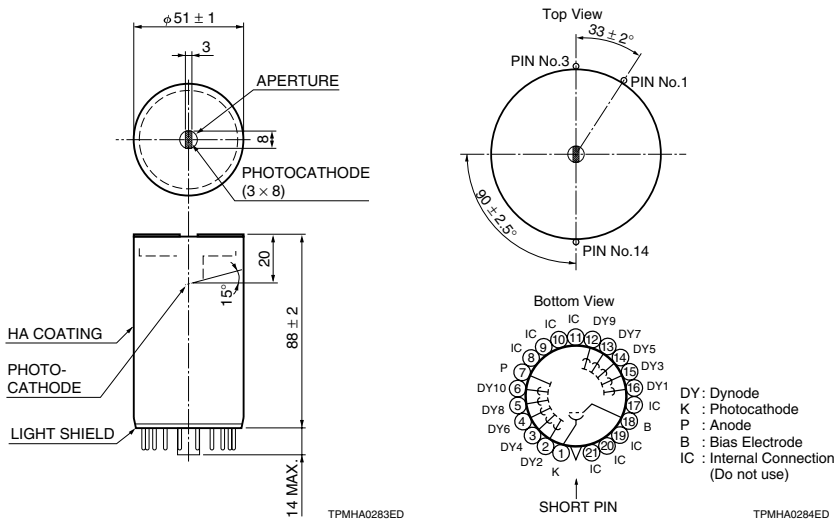

[Cautions for operation]

- Operate the tube at the anode current less than 2 μA while the entire photocathode is illuminated in order to avoid the photocathode damage due to excessive cathode current.
- In order to protect the photocathode, the high voltage should be increased or decreased gradually.
- When the R5509-43 or -73 shall be operated, do not supply the high voltage before the tube is cooled down to -70°C at least.
- Use the exclusive cooler **PC176TSCE005** or **PC176TSCE006** for cooling.

[Warranty]

- A cooler other than specified may cause a trouble in the tube like loss of performance or a mechanical damage. Any trouble caused in association with a cooler other than specified shall not be subject to warranty.
- Hamamatsu photomultiplier tubes are warranted to the original purchase for a period of 12 months following the date of shipment. The warranty is limited to repair or replacement of any defective material due to defects in workmanship or materials used in manufacture.

RELATED PRODUCTS

Exclusive cooler PC176TSCE005, PC176TSCE006 for R5509-43, -73

PC176TSCE005 and PC176TSCE006 are exclusively designed coolers for R5509-43 and -73 using liquid nitrogen. The dark current of R5509-43 and -73 will be reduced drastically by cooling so that the PMT will be able to detect very weak light.

The cooler housing is magnetically and electrostatically shielded excluding external noises to provide very stable and high S/N ratio measurement. Hamamatsu also provides the PC176TSCE006 cooler suitable for a self-pressurized liquid nitrogen container.

■ FEATURES

- Temperature controllable range: 0°C to -100°C (R5509-43, -73 operating range shall be: -70°C to -90°C)
- Exclusive socket assembly with load resistor selectable circuit
- Built-in magnetic electrostatic shield
- Built-in warning buzzer for liquid nitrogen supply shortage

■ SPECIFICATIONS

Parameter	PC176TSCE005	PC176TSCE006
Coolant medium	Liquid Nitrogen Vaporization	
Temperature Controllable Range	0°C to -100°C (continuously adjustable)	
Cool-down Time	Approx. 2 h (-80°C setting)	
Liquid Nitrogen Consumption rate (Max.)	0.75 L/h (-100°C setting)	
Dry Nitrogen	Gas Pressure	35 kPa
	Consumption rate	47 L (14.7 MPa)/100 h
Socket Assembly	Voltage Divider Current	158 μA (PMT Supply Voltage: -1750 V)
	-HV Connector	SHV-R
	Signal Connector	BNC-R
	Load Resistor	50 Ω / 1 k Ω / 100 k Ω / 10 M Ω / Open
AC Input Voltage	100 V to 120 V, 220 V to 240 V (50/60 Hz)	
Power Consumption	15 VA	
Operating Ambient Temperature	Less than $+30^\circ\text{C}$	
Weight	Cooling Unit	Approx. 6 kg
	Controller and others	Approx. 11 kg
Components	Cooling Unit, Controller, Solenoid Control Cable, Solenoid Valve, 3/8" OD Rubber Tube, Insulated Transfer Hose, LN ₂ Transfer Head for 35 mm to 40 mm Neck OD LN ₂ Dewar	Cooling unit, Controller, Solenoid Control Cable, Flow Limit Valve, Solenoid Valve, Insulated Transfer Hose, Control Solenoid with Connecting Hose with 3/4-16UNF or PT 1/4 Screws in End

■ DIMENSIONAL OUTLINE (Unit: mm)

Cooling unit

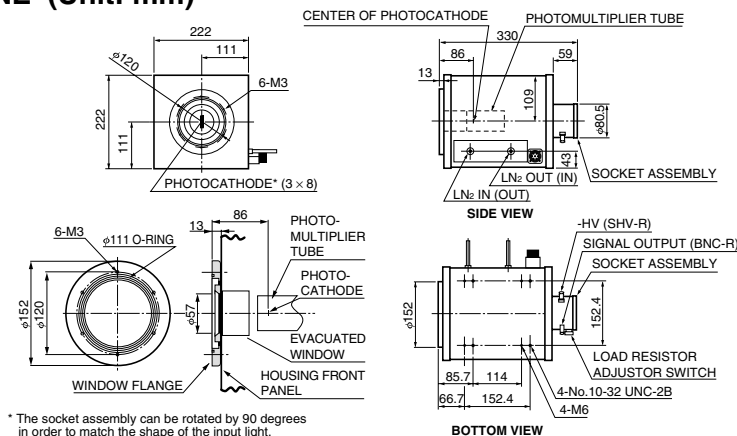

* The socket assembly can be rotated by 90 degrees in order to match the shape of the input light.

RELATED PRODUCTS

Exclusive cooler PC176TSCE005, PC176TSCE006 for R5509-43, -73

CONNECTION DIAGRAM

PC176TSCE005 *NOT SUPPLIED

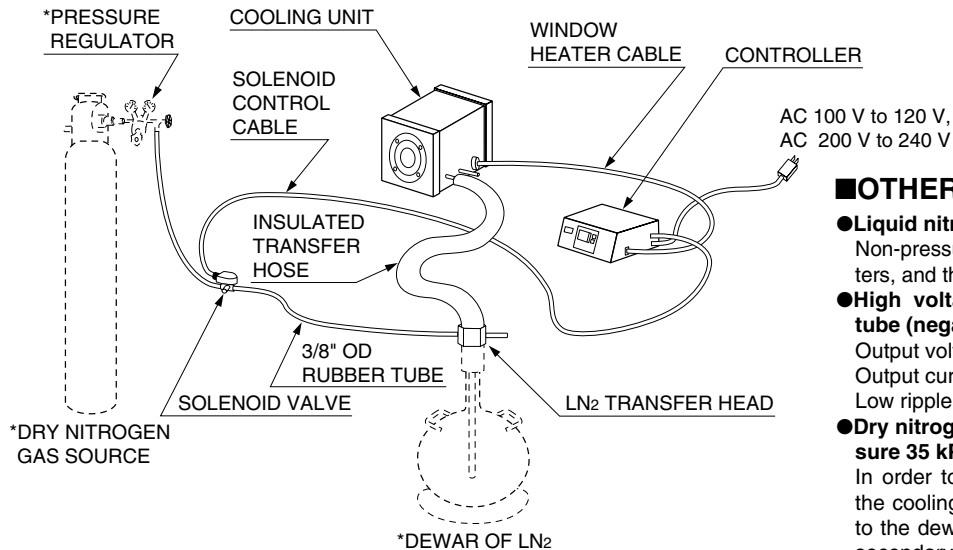

OTHER ACCESSORIES REQUIRED

Liquid nitrogen dewar

Non-pressurized dewar having a capacity of 10 to 50 liters, and the neck outer diameter between 35 and 40 mm.

High voltage power supply for the photomultiplier tube (negative high voltage)

Output voltage: more than -1750 V

Output current: more than 0.2 mA

Low ripple, High stability

Dry nitrogen gas, pressure regulator (secondary pressure 35 kPa), pressure gauge

In order to supply a proper amount of liquid nitrogen to the cooling unit, an external pressure needs to be added to the dewar. A pressure regulator capable of reducing a secondary pressure to 35 kPa is necessary when used with a dry nitrogen gas container. Connect the 3/8" rubber tube to the exit of the pressure regulator.

PC176TSCE006 *NOT SUPPLIED

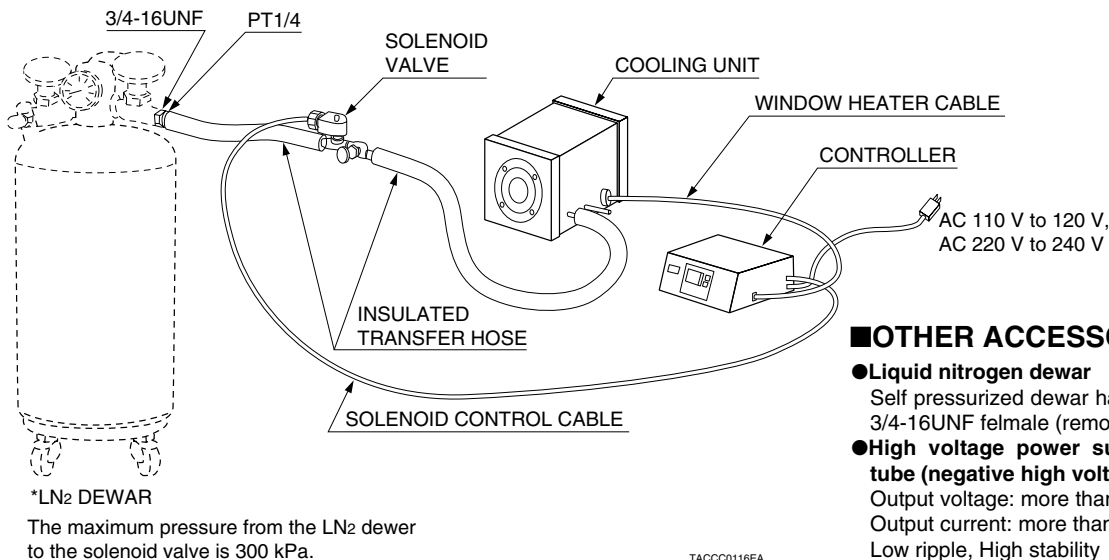

OTHER ACCESSORIES REQUIRED

Liquid nitrogen dewar

Self pressurized dewar having a matching screw of either 3/4-16UNF female (removable) or PT 1/4 male.

High voltage power supply for the photomultiplier tube (negative high voltage)

Output voltage: more than -1750 V

Output current: more than 0.2 mA

Low ripple, High stability

* Peripheral equipments such as the relay optics for connecting a monochromator (A8996), insulating window with lens or high voltage power supply can be provided.

For photon counting, preamp, photon counting unit and photon counting board or counter are necessary.

Please consult with Hamamatsu for assistance.

Subject to local technical requirements and regulations, availability of products included in this promotional material may vary. Please consult with our sales office. Information furnished by HAMAMATSU is believed to be reliable. However, no responsibility is assumed for possible inaccuracies or omissions. Specifications are subject to change without notice. No patent rights are granted to any of the circuits described herein. ©2003 Hamamatsu Photonics K.K.

HAMAMATSU

WEB SITE <http://www.hamamatsu.com>

HAMAMATSU PHOTONICS K.K., Electron Tube Center

314-5, Shimokanzo, Toyooka-village, Iwata-gun, Shizuoka-ken, 438-0193, Japan, Telephone: (81)539/62-5248, Fax: (81)539/62-2205

U.S.A.: Hamamatsu Corporation: 360 Foothill Road, P. O. Box 6910, Bridgewater, N.J. 08807-0910, U.S.A., Telephone: (1)908-231-0960, Fax: (1)908-231-1218 E-mail: usa@hamamatsu.com

Germany: Hamamatsu Photonics Deutschland GmbH: Arzbergerstr. 10, D-82211 Herrsching am Ammersee, Germany, Telephone: (49)8152-375-0, Fax: (49)8152-2658 E-mail: info@hamamatsu.de

France: Hamamatsu Photonics France S.A.R.L.: 8, Rue du Saule Trapu, Parc du Moulin de Massy, 91882 Massy Cedex, France, Telephone: (33)1 69 53 71 00, Fax: (33)1 69 53 71 10 E-mail: infos@hamamatsu.fr

United Kingdom: Hamamatsu Photonics UK Limited: 2 Howard Court, 10 Tewin Road Welwyn Garden City Hertfordshire AL7 1BW, United Kingdom, Telephone: 44-(0)1707-294888, Fax: 44(0)1707-325777 E-mail: info@hamamatsu.co.uk

North Europe: Hamamatsu Photonics Norden AB: Smidesvägen 12, SE-171-41 SOLNA, Sweden, Telephone: (46)8-509-031-00, Fax: (46)8-509-031-01 E-mail: info@hamamatsu.se

Italy: Hamamatsu Photonics Italia: S.R.L.: Strada della Moia, 1/E, 20020 Arese, (Milano), Italy, Telephone: (39)02-935 81 733, Fax: (39)02-935 81 741 E-mail: info@hamamatsu.it

TPMH1284E03
FEB. 2003 IP