

Flat panel sensor C7942CA, C7943CA

Acquire digital X-ray image in real time and 170 & 176 mm diagonal size

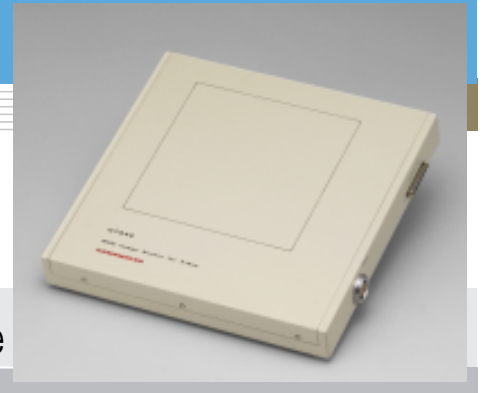

Hamamatsu C7942CA and C7943CA Flat Panel Sensors are digital X-ray image sensors newly developed as key devices for non-destructive inspection, biomedical imaging, X-ray microscopy and other real-time X-ray imaging applications requiring high resolution and high image quality. C7942CA and C7943CA consist of a sensor board and a control board, both assembled in a thin, flat and compact package. The sensor board contains a CsI scintillator plate, a two-dimensional photodiode array with FET switches and a signal processing IC chip. The photodiode array has a 2400 × 2400 (C7942CA) or 1248 × 1248 (C7943CA) pixel format with minimized blooming and is highly sensitive to bluish green light emitted from the CsI scintillator. Each row of pixels is addressed in sequence by the vertical shift register connected to the gate line.

Light emission occurs when X-rays are absorbed in the CsI scintillator. This light emission enters directly into the two-dimensional photodiode array where an electric charge is stored in each pixel according to the light intensity. This charge is then transferred to the corresponding data line by applying a control signal to the vertical shift register.

The sensor board also has 8 charge sensitive amplifier arrays each having 300 channel (C7942CA) or 156 channel (C7943CA) amplifiers with a horizontal shift register. These amplifiers with a total of 2400 channels (C7942CA) or 1248 channels (C7943CA) are connected to a CDS (Correlated Double Sampling) circuit that senses the charge on each video line and sends it as the analog video signal from each amplifier array. The control board converts the analog video signal into a 12-bit digital signal and outputs it to an external frame grabber from a 12-bit parallel port. C7943CA delivers a frame rate of 30 frames per second using 4 × 4 binning and is ideal for high frame rate applications. On the other hand, C7942CA is ideal for applications requiring high resolution because of its 50 μm pixel size. Massive digital image data can easily be monitored on a display unit by using a frame grabber board and video memory installed in the PC. C7942CA and C7943CA will prove ideal tools for real-time X-ray imaging and processing where easy-to-use, high-resolution X-ray digital image sensors are needed.

Applications

- Non-destructive inspection
- Digital X-ray photography

Features

- C7942CA: 2400 × 2400 pixels
C7943CA: 1248 × 1248 pixels
- Digital output (12 bit)
- Dynamic picture image
C7942CA: 9 frame/s (4 × 4 binning)
C7943CA: 30 frame/s (4 × 4 binning)
- Low noise and wide dynamic range
- Compact package
- Easy use

■ Block diagram (C7942CA)

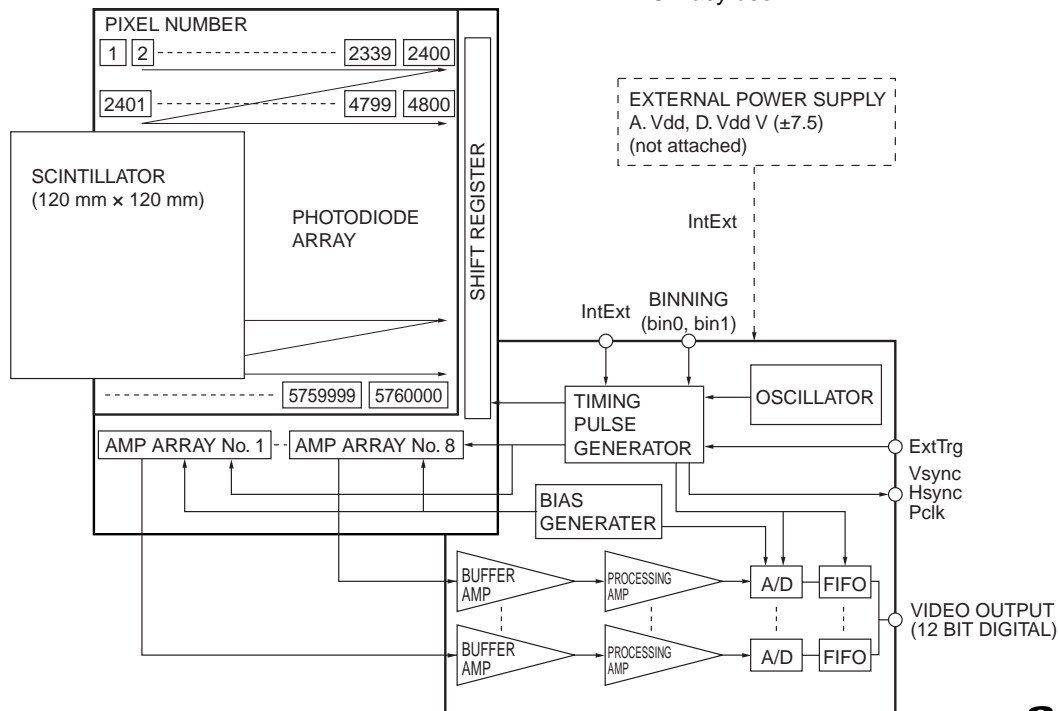

KACCC0137EA

SOLID STATE DIVISION

Functional specification

| Parameter | C7942CA | C7943CA |
|---|------------------------------|---------|
| Readout | Charge amplifier array | |
| Feedback capacitance of each amplifier | 0.15 pF | 0.6 pF |
| Video output (Data1 - 12) | RS-422 (differential) 12 bit | |
| Output data rate | 15.15 MHz | |
| Synchronous signal (Vsync, Hsync, Pclk) | RS-422 (differential) | |
| bin0, 1, ExtTrg, IntExt | TTL | |

Absolute maximum ratings (Ta=25 °C)

| Parameter | Symbol | Value | Unit |
|--|-----------|----------|------|
| Supply voltage for digital circuitry (+5 V) | D.vdd | +6.0 | V |
| Supply voltage for analog circuitry (+5 V) | A.vdd | +6.0 | V |
| Supply voltage for analog circuitry (±7.5 V) | V(+/-7.5) | ±12 | V |
| Input voltage (bin0, 1, ExtTrg, IntExt) | Vin | 0 to 6.0 | V |
| Operating temperature (not condensed) | Topr | 0 to +35 | °C |
| Storage temperature (not condensed) | Tstg | 0 to +50 | °C |

Specification (Unless otherwise noted, Typ. Ta=25 °C A.vdd= 5.0 V, D.vdd= 5.0 V, V (±7.5)= ±7.5 V)

| Parameter | Symbol | C7942CA | C7943CA | Unit |
|---|----------|-----------------------|-----------------------|---------------|
| Pixel size | | 50 | 100 | µm |
| Active area | | 120 × 120 | 124.8 × 124.8 | mm |
| Pixel number | | 5.76 (2400 × 2400) | 1.56 (1248 × 1248) | M pixels |
| Number of active pixels (horizontal × vertical) | - | 2240 × 2368 | 1216 × 1232 | pixels |
| Frame speed (single operation) | Sf (int) | 2 | 7 | frame/s |
| Frame speed (2 × 2 binning) | | 4 | 15 | frame/s |
| Frame speed (4 × 4 binning) | | 9 | 30 | frame/s |
| Frame speed external (single operation) | Sf (ext) | Sf (int) to 0.1 | Sf (int) to 0.1 | frame/s |
| Noise (rms.) | N (rms.) | 1100 | 2300 | electrons |
| Saturation charge | Csat | 2.2 | 10 | M electrons |
| Resolution | Reso | 8 | 5 | line pairs/mm |
| Dynamic range | | 2000 | 4300 | - |
| Defect line * | - | 20 Max. | 10 Max. | lines |
| Scintillator | - | CsI | | - |

* Without a couple of adjacent defect line that has no response.

Timing chart

To acquire images through an image grabber board, parameters that match the following timing chart should be described in the software program or parameter file.

Internal mode

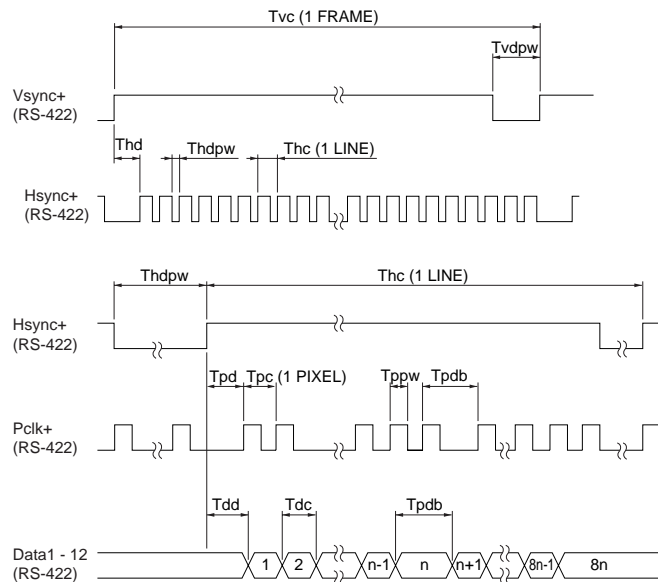

In case of C7942CA, the number of n is 300.
In case of C7943CA the number of n is 156.

External mode

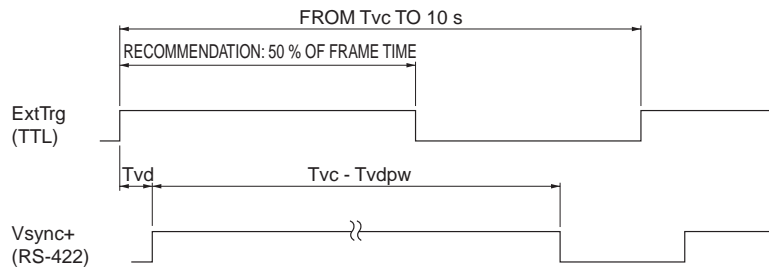

Hsync+, Pclk and Data 1-12 are the same as internal trigger mode.

KACCC0139EB

C7942CA

1 × 1 mode (Typ.)

| Parameter | | Symbol | Value | Unit |
|-----------|---|--------|-------|------|
| Vsync | Delay time (only external trigger mode) | Tvd | 390 | μs |
| | Cycle time | Tvc | 470 | ms |
| | Dummy pulse width | Tvdpw | 770 | μs |
| Hsync | Delay time | Thd | 1.4 | μs |
| | Cycle time | Thc | 190 | μs |
| | Dummy pulse width | Thdpw | 35 | μs |
| Pclk | Delay time | Tpd | 65 | ns |
| | Cycle time | Tpc | 66 | ns |
| | Pulse width | Tppw | 33 | ns |
| | Delay time between each block | Tpdb | 200 | ns |
| Data1-12 | Delay time | Tdd | 34 | ns |
| | Cycle time | Tdc | 66 | ns |

2 × 2 mode (Typ.)

| Parameter | | Symbol | Value | Unit |
|-----------|---|--------|-------|------|
| Vsync | Delay time (only external trigger mode) | Tvd | 390 | μs |
| | Cycle time | Tvc | 230 | ms |
| | Dummy pulse width | Tvdpw | 770 | μs |
| Hsync | Delay time | Thd | 1.4 | μs |
| | Cycle time | Thc | 190 | μs |
| | Dummy pulse width | Thdpw | 110 | μs |
| Pclk | Delay time | Tpd | 65 | ns |
| | Cycle time | Tpc | 66 | ns |
| | Pulse width | Tppw | 33 | ns |
| | Delay time between each block | Tpdb | 200 | ns |
| Data1-12 | Delay time | Tdd | 34 | ns |
| | Cycle time | Tdc | 66 | ns |

4 × 4 mode (Typ.)

| Parameter | | Symbol | Value | Unit |
|-----------|---|--------|-------|------|
| Vsync | Delay time (only external trigger mode) | Tvd | 390 | μs |
| | Cycle time | Tvc | 117 | ms |
| | Dummy pulse width | Tvdpw | 770 | μs |
| Hsync | Delay time | Thd | 1.4 | μs |
| | Cycle time | Thc | 190 | μs |
| | Dummy pulse width | Thdpw | 150 | μs |
| Pclk | Delay time | Tpd | 65 | ns |
| | Cycle time | Tpc | 66 | ns |
| | Pulse width | Tppw | 33 | ns |
| | Delay time between each block | Tpdb | 200 | ns |
| Data1-12 | Delay time | Tdd | 34 | ns |
| | Cycle time | Tdc | 66 | ns |

Note) The numbers of significant figures is two. (except Tvc)

C7943CA

1 × 1 mode (Typ.)

| | Parameter | Symbol | Value | Unit |
|----------|---|--------|-------|------|
| Vsync | Delay time (only external trigger mode) | Tvd | 210 | μs |
| | Cycle time | Tvc | 130 | ms |
| | Dummy pulse width | Tvdpw | 420 | μs |
| Hsync | Delay time | Thd | 1.8 | μs |
| | Cycle time | Thc | 110 | μs |
| | Dummy pulse width | Thdpw | 22 | μs |
| Pclk | Delay time | Tpd | 65 | ns |
| | Cycle time | Tpc | 66 | ns |
| | Pulse width | Tppw | 33 | ns |
| | Delay time between each block | Tpdb | 200 | ns |
| Data1-12 | Delay time | Tdd | 33 | ns |
| | Cycle time | Tdc | 66 | ns |

2 × 2 mode (Typ.)

| | Parameter | Symbol | Value | Unit |
|----------|---|--------|-------|------|
| Vsync | Delay time (only external trigger mode) | Tvd | 210 | μs |
| | Cycle time | Tvc | 66 | ms |
| | Dummy pulse width | Tvdpw | 420 | μs |
| Hsync | Delay time | Thd | 1.8 | μs |
| | Cycle time | Thc | 110 | μs |
| | Dummy pulse width | Thdpw | 63 | μs |
| Pclk | Delay time | Tpd | 65 | ns |
| | Cycle time | Tpc | 66 | ns |
| | Pulse width | Tppw | 33 | ns |
| | Delay time between each block | Tpdb | 200 | ns |
| Data1-12 | Delay time | Tdd | 33 | ns |
| | Cycle time | Tdc | 66 | ns |

4 × 4 mode (Typ.)

| | Parameter | Symbol | Value | Unit |
|----------|---|--------|-------|------|
| Vsync | Delay time (only external trigger mode) | Tvd | 210 | μs |
| | Cycle time | Tvc | 33 | ms |
| | Dummy pulse width | Tvdpw | 420 | μs |
| Hsync | Delay time | Thd | 1.8 | μs |
| | Cycle time | Thc | 110 | μs |
| | Dummy pulse width | Thdpw | 84 | μs |
| Pclk | Delay time | Tpd | 65 | ns |
| | Cycle time | Tpc | 66 | ns |
| | Pulse width | Tppw | 33 | ns |
| | Delay time between each block | Tpdb | 200 | ns |
| Data1-12 | Delay time | Tdd | 33 | ns |
| | Cycle time | Tdc | 66 | ns |

Note) The numbers of significant figures is two.

■ System requirements

To operate C7942CA and C7943CA Flat Panel Sensors at full performance, the following system and peripherals are required.

PC: IBM compatible PC running on Windows 98 or later operating system

Digital frame grabber card: Monochrome 16 bits or more, pixel clock 16 MHz or more, RS-422 interface synchronous signal (See the frame grabber manual.)

The National Instruments IMAQ PCI-1424 (NI parts No. 777662-01) frame grabber with optional memory 64 MB (NI parts No. 920130-64) has been verified to successfully acquire 12-bit digital images from both C7942CA and C7943CA. The IMAQ PCI-1422 (NI parts No. 777959-01) also acquires satisfactory images from C7943CA. You can utilize the demonstration software that comes with the frame grabber as a simple viewer, to acquire and save an image. To do so, refer to the frame grabber user's guide for how to use the camera information file for the demonstration software.

Power source: A. V_{dd} = +5.0 ± 0.1 V (700 mA), D. V_{dd} = +5.0 ± 0.1 V (1000 mA), V (±7.5) = ±7.5 ± 0.5 V (±100 mA). Use of a series power supply is recommended. (Avoid using a switching power supply.) A power cable (terminated with an FGG.2B.307.CLAD92Z plug at one end and open at the other end; 2 m; see Table 2.) comes supplied with C7942CA and C7943CA. An optional 36-pin cable for interface with the 36-pin receptacle (see Table 1) on C7942CA and C7943CA is also available for synchronous signal input, video output and external control.

The voltages described above are specified at the flat panel sensor side. The impedance of the power cable attached with the flat panel sensor is low enough but it causes 0.1 V approx. drop. Therefore the voltage at the power source side should be set 0.1 V higher than the voltage specified above.

Table 1 Pin assignment of 36-pin receptacle

| Pin No. | Signal | Pin No. | Signal |
|---------|--------------|---------|---------------|
| 1 | Data1+ (MSB) | 19 | Data1- (MSB) |
| 2 | Data2+ | 20 | Data2- |
| 3 | Data3+ | 21 | Data3- |
| 4 | Data4+ | 22 | Data4- |
| 5 | Data5+ | 23 | Data5- |
| 6 | Data6+ | 24 | Data6- |
| 7 | Data7+ | 25 | Data7- |
| 8 | Data8+ | 26 | Data8- |
| 9 | Data9+ | 27 | Data9- |
| 10 | Data10+ | 28 | Data10- |
| 11 | Data11+ | 29 | Data11- |
| 12 | Data12+(LSB) | 30 | Data12- (LSB) |
| 13 | bin0 (TTL) | 31 | Gnd |
| 14 | bin1 (TTL) | 32 | Gnd |
| 15 | ExtTrg (TTL) | 33 | IntExt (TTL) |
| 16 | Vsync+ | 34 | Vsync- |
| 17 | Hsync+ | 35 | Hsync- |
| 18 | Pclk+ | 36 | Pclk- |

Unless otherwise noted, signal level is RS-422.

36-pin receptacle: TX20A-36R-D2GF1-A1L made by JAE (Japan Aviation Electronics Industry limited)

36-pin mating plug: TX20A-36PH1-D2P1-D1 made by JAE (Japan Aviation Electronics Industry limited)

Table 2 Power pin assignment and cable color

| Pin No. | Color | Signal |
|---------|--------|--------------|
| 1 | Brown | +7.5 V |
| 2 | Red | Analog GND |
| 3 | Orange | -7.5 V |
| 4 | Yellow | Analog GND |
| 5 | Green | Analog +5 V |
| 6 | Blue | Digital GND |
| 7 | Purple | Digital +5 V |
| Shield | - | Analog GND |

7-pin power plug: FGG.2B.307.CLAD92Z made by LEMO S. A. (<http://www.lemo.ch>)

7-pin power receptacle: ECG.2B.307.CLV made by LEMO S. A.

■ Connection

Install the frame grabber board into the PC by following the manufacturer's instructions. When a general-purpose frame grabber board is used, binning or trigger operation for bin0, bin1, IntExt and ExtTrig can be controlled with its digital I/O control.

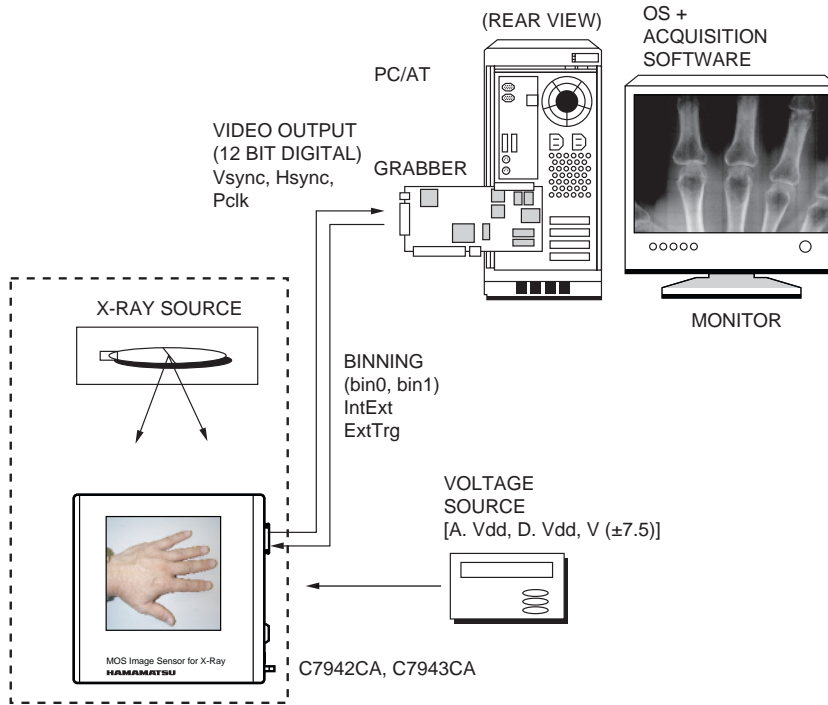

KACCC0140EA

■ Dimensional outline (unit: mm)

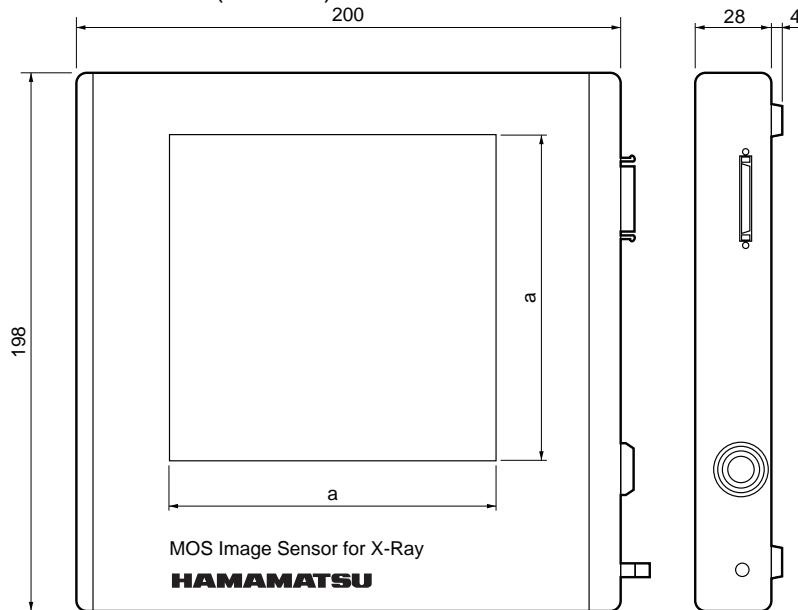

Top cover is made of aluminum 1.0 mm thick.

| | C7942CA | C7943CA |
|---|---------|---------|
| a | 120 | 124.8 |

KACCA0095EA

Optional 36-pin cables

Two types of 36-pin cables are provided as options for connecting to the frame grabber.

Type A (A8406-01): General-purpose interface cable for digital frame grabber.

Type B (A8406-02): Interface cable for IMAQ PCI-1424 grabber board.

| Type | Cable type No. | Cable length | Cable end | Cable end | |
|------|----------------|--------------|------------------------|------------------------|----------------|
| A | A8406-01 | 5 m | TX20A-36PH1-D2P1-D1 *1 | open | |
| | A8406-06 | 7 m | | | |
| | A8406-07 | 10 m | | | |
| | A8406-08 | 12 m | | | |
| B | A8406-02 | 5 m | | TX20A-36PH1-D2P1-D1 *1 | PCS-XE100MA *2 |
| | A8406-03 | 7 m | | | |
| | A8406-04 | 10 m | | | |
| | A8406-05 | 12 m | | | |

*1: Made by JAE (Japan Aviation Electronics Industry, Limited)

*2: Made by Honda Tsushin Kogyo Co. Ltd.

A8406-01/-06/-07/-08 cable for general frame grabber

A8406-01/-06/-07/-08 is a cable that connects the Flat Panel Sensor (C7942CA or C7943CA) to a general frame grabber. One end of this cable has a 36-pin plug mating with the C7942CA or C7943CA digital output receptacle, but the other end is left open. Connect the open end to a plug that mates with the frame grabber to be used. Cable color coding and specifications are shown in the table below.

■ Cable color coding and specifications

| Pin No. | Signal | Cable color | Marking color | Pin No. | Signal | Cable color | Marking color |
|---------|---------------|-------------|---------------|---------|---------------|-------------|---------------|
| 1 | Data1+ (MSB) | blue | - | 19 | Data1- (MSB) | orange | - |
| 2 | Data2+ | green | - | 20 | Data2- | brown | - |
| 3 | Data3+ | gray | - | 21 | Data3- | red | - |
| 4 | Data4+ | black | - | 22 | Data4- | yellow | - |
| 5 | Data5+ | pink | - | 23 | Data5- | purple | - |
| 6 | Data6+ | white | - | 24 | Data6- | blue | red |
| 7 | Data7+ | orange | white | 25 | Data7- | green | white |
| 8 | Data8+ | brown | white | 26 | Data8- | gray | white |
| 9 | Data9+ | red | white | 27 | Data9- | black | white |
| 10 | Data10+ | yellow | black | 28 | Data10- | pink | black |
| 11 | Data11+ | purple | white | 29 | Data11- | white | blue |
| 12 | Data12+ (LSB) | blue | red | 30 | Data12- (LSB) | orange | white |
| 13 | bin0 (TTL) | green | white | 31 | Gnd | brown | white |
| 14 | bin1 (TTL) | gray | white | 32 | Gnd | red | white |
| 15 | ExtTrg (TTL) | black | white | 33 | IntExt (TTL) | yellow | black |
| 16 | Vsync+ | pink | black | 34 | Vsync- | purple | white |
| 17 | Hsync+ | white | blue | 35 | Hsync- | blue | black |
| 18 | Pclk+ | orange | black | 36 | Pclk- | green | black |

■ Dimensional outline (unit: mm)

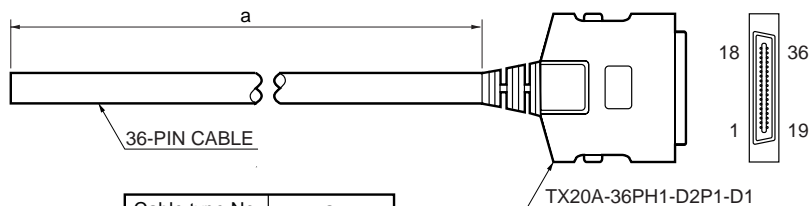

| Cable type No. | a |
|----------------|-------------|
| A8406-01 | 5000 ± 140 |
| A8406-06 | 7000 ± 140 |
| A8406-07 | 10000 ± 140 |
| A8406-08 | 12000 ± 140 |

KACCA0096EB

A8406-02/-03/-04/-05 cable for IMAQ PCI-1424 frame grabber

A8406-02/-03/-04/-05 cable is designed to connect the Flat Panel Sensor (C7942CA or C7943CA) to the National Instrument IMAQ PCI-1424 (NI parts No. 777662-01) digital frame grabber board. Both ends of this cable have connectors. One end is a 36-pin plug mating with the C7942CA or C7943CA digital output receptacle, while the other end is a 100-pin plug for the IMAQ PCI-1424.

Pin connection for A8406-02

| TX20A-36PH1-D2P1-D1 Pin No. | Signal | PCS-XE100MA Pin No. | TX20A-36PH1-D2P1-D1 Pin No. | Signal | PCS-XE100MA Pin No. |
|--------------------------------|---------------|------------------------|--------------------------------|---------------|------------------------|
| 1 | Data1+ (MSB) | 23 | 19 | Data1- (MSB) | 24 |
| 2 | Data2+ | 21 | 20 | Data2- | 22 |
| 3 | Data3+ | 19 | 21 | Data3- | 20 |
| 4 | Data4+ | 17 | 22 | Data4- | 18 |
| 5 | Data5+ | 15 | 23 | Data5- | 16 |
| 6 | Data6+ | 13 | 24 | Data6- | 14 |
| 7 | Data7+ | 11 | 25 | Data7- | 12 |
| 8 | Data8+ | 9 | 26 | Data8- | 10 |
| 9 | Data9+ | 7 | 27 | Data9- | 8 |
| 10 | Data10+ | 5 | 28 | Data10- | 6 |
| 11 | Data11+ | 3 | 29 | Data11- | 4 |
| 12 | Data12+ (LSB) | 1 | 30 | Data12- (LSB) | 2 |
| 13 | bin0 (TTL) | 33 | 31 | Gnd | 99 |
| 14 | bin1 (TTL) | 35 | 32 | Gnd | 100 |
| 15 | ExtTrg (TTL) | 37 | 33 | IntExt (TTL) | 39 |
| 16 | Vsync+ | 41 | 34 | Vsync- | 42 |
| 17 | Hsync+ | 43 | 35 | Hsync- | 44 |
| 18 | Pclk+ | 49 | 36 | Pclk- | 50 |

Dimensional outline (unit: mm)

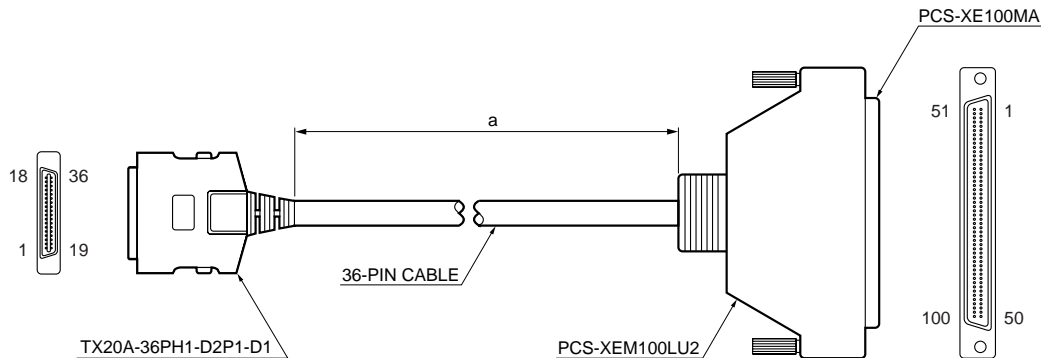

| Cable type No. | a |
|----------------|-------------|
| A8406-02 | 5000 ± 140 |
| A8406-03 | 7000 ± 140 |
| A8406-04 | 10000 ± 140 |
| A8406-05 | 12000 ± 140 |

KACCA0097EB

Notice) · Do not subject the Flat Panel Sensors to strong vibration or shock. (Strong shock such as drop impacts may cause permanent damage to these sensors.)

- Users must take responsibility for implementing X-ray shielding safety measures to avoid the risk of X-ray exposure.
- This product was not designed and manufactured for use as a medical X-ray device. System manufacturers must take responsibility for obtaining MHW or FDA approval when incorporating this product into a medical diagnostics system.
- This product is warranted for a period of 12 months after the date of the shipment.

The warranty is limited to make a replacement or repair of any defective material due to defects in workmanship or materials used in manufacture. It does not cover loss or damage of the product due to natural calamity, misuse or total radiation dose over 1 million Roentgen (80 kV) even within the warranty period.

HAMAMATSU

Information furnished by HAMAMATSU is believed to be reliable. However, no responsibility is assumed for possible inaccuracies or omissions. Specifications are subject to change without notice. No patent rights are granted to any of the circuits described herein. ©2003 Hamamatsu Photonics K.K.

HAMAMATSU PHOTONICS K.K., Solid State Division

1126-1 Ichino-cho, Hamamatsu City, 435-8558 Japan, Telephone: (81) 053-434-3311, Fax: (81) 053-434-5184, <http://www.hamamatsu.com>

U.S.A.: Hamamatsu Corporation: 360 Foothill Road, P.O.Box 6910, Bridgewater, N.J. 08807-0910, U.S.A., Telephone: (1) 908-231-0960, Fax: (1) 908-231-1218

Germany: Hamamatsu Photonics Deutschland GmbH: Arzbergerstr. 10, D-82211 Herrsching am Ammersee, Germany, Telephone: (49) 08152-3750, Fax: (49) 08152-2658

France: Hamamatsu Photonics France S.A.R.L.: 8, Rue du Saule Trapu, Parc du Moulin de Massy, 91882 Massy Cedex, France, Telephone: 33-(1) 69 53 71 00, Fax: 33-(1) 69 53 71 10

United Kingdom: Hamamatsu Photonics UK Limited: 2 Howard Court, 10 Tewin Road, Welwyn Garden City, Hertfordshire AL7 1BW, United Kingdom, Telephone: (44) 1707-294888, Fax: (44) 1707-325777

North Europe: Hamamatsu Photonics Norden AB: Smidesvägen 12, SE-171 41 Solna, Sweden, Telephone: (46) 8-509-031-00, Fax: (46) 8-509-031-01

Italy: Hamamatsu Photonics Italia S.R.L.: Strada della Moia, 1/E, 20020 Arese, (Milano), Italy, Telephone: (39) 02-935-81-733, Fax: (39) 02-935-81-741

Cat. No. KACC1056E12
Sep. 2003 DN