

Infrared LED

L7022

High power LED array for spatial light transmission



Features

- Small package
- High radiant output power
- Directivity suitable for automobile VICS

Applications

- Spatial light transmission (automobile VICS)

■ Absolute maximum ratings (Ta=25 °C, following figure external wiring diagram)

Parameter	Symbol	Condition	Value	Unit
Forward current	I_F		160	mA
Reverse voltage	V_R		4	V
Pulse forward current	I_{FP}	Pulse width =10 μ s Duty ratio =1 %	1.6	A
Operating temperature	T_{opr}		-30 to +85	°C
Storage temperature	T_{stg}		-40 to +110	°C

■ Electrical and optical characteristics (Ta=25 °C, following figure external wiring diagram)

Parameter	Symbol	Condition	Min.	Typ.	Max.	Unit
Peak emission wavelength	λ_p	$I_F=100$ mA	830	870	890	nm
Spectral half width	$\Delta\lambda$	$I_F=100$ mA	-	40	-	nm
Forward voltage	V_F	$I_F=100$ mA	-	4.6	5.0	V
Pulse forward voltage	V_{FP}	$I_F=900$ mA	-	7.3	8.3	V
Reverse current	I_R	$V_R=4$ V	-	-	10	μ A
Radiant flux	ϕ_e	$I_F=100$ mA	55	78	-	mW
Pulse radiant strength	I_{ep}	$I_F=900$ mA	1350	1600	-	mW/sr
Cut-off frequency	f_c	$I_F=50$ mA + 1 mAp-p	7	12	-	MHz

■ External wiring diagram

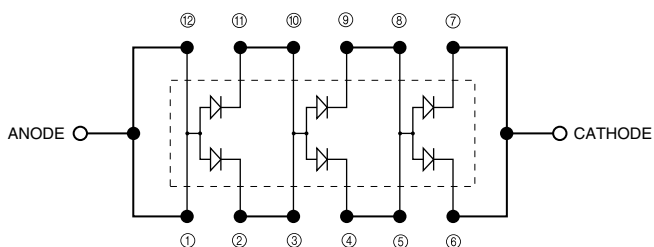

Bold solid line: External wiring
Thin solid line: Internal wiring
Broken line : Molded area

KLED0013EA

SOLID STATE DIVISION

■ Emission spectrum

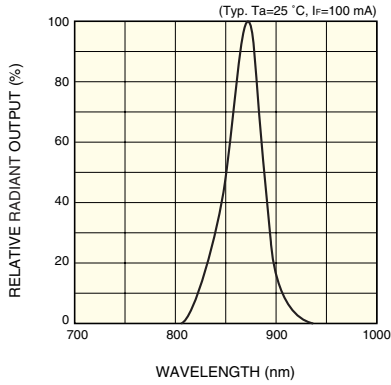

KLEDB0168EA

■ Radiant output vs. forward current

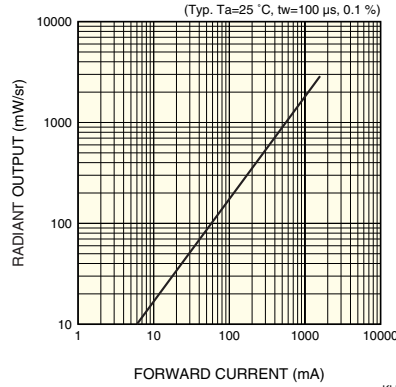

KLEDB0169EA

■ Forward current vs. forward voltage

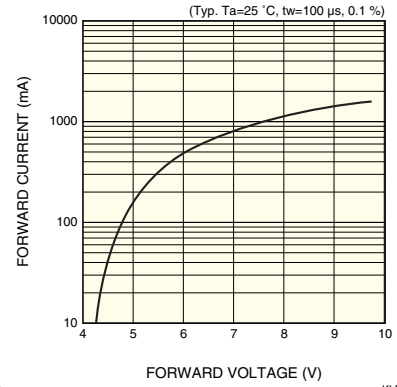

KLEDB0217EA

■ Directivity (direction in short side)

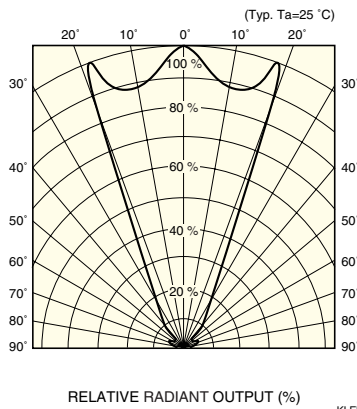

KLEDB0069EB

■ Directivity (direction in long side)

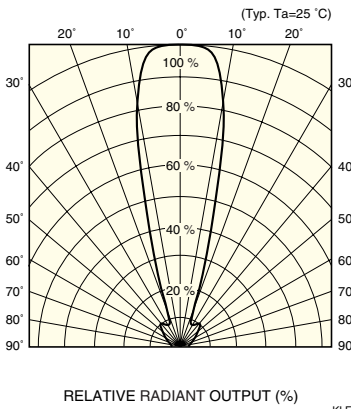

KLEDB0170EA

■ Radiant output vs. ambient temperature

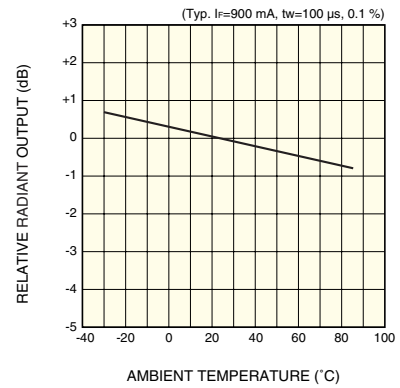

KLEDB0171EA

■ Allowable forward current vs. ambient temperature

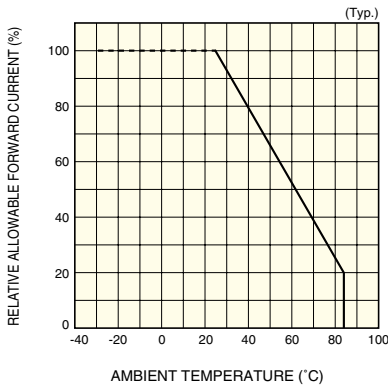

KLEDB0027EB

■ Dimensional outline (unit: mm)

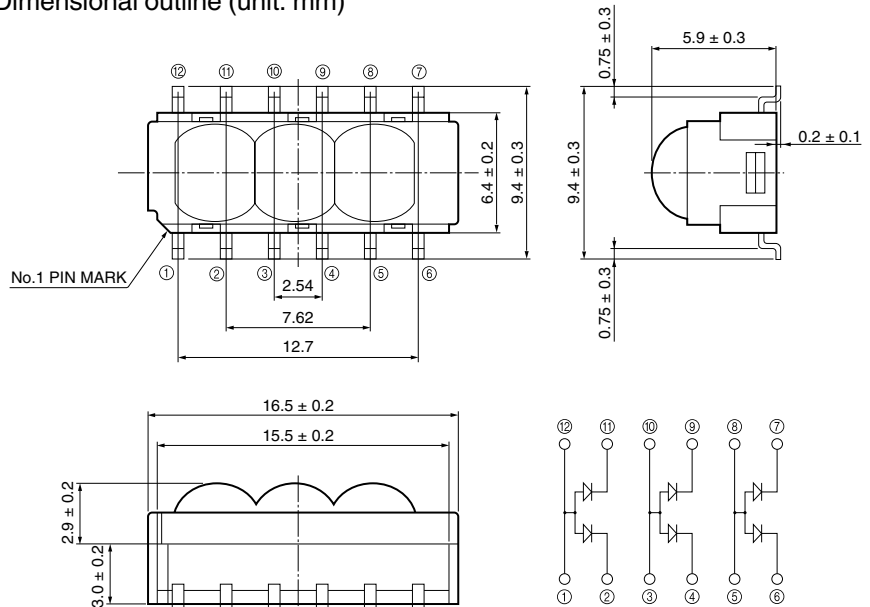

KLEDA0021EB

HAMAMATSU

HAMAMATSU PHOTONICS K.K., Solid State Division

1126-1 Ichino-cho, Hamamatsu City, 435-8558 Japan, Telephone: (81) 053-434-3311, Fax: (81) 053-434-5184, <http://www.hamamatsu.com>

U.S.A.: Hamamatsu Corporation: 360 Foothill Road, P.O.Box 6910, Bridgewater, N.J. 08807-0910, U.S.A., Telephone: (1) 908-231-0960, Fax: (1) 908-231-1218

Germany: Hamamatsu Photonics Deutschland GmbH: Arzbergerstr. 10, D-82211 Herrsching am Ammersee, Germany, Telephone: (49) 08152-3750, Fax: (49) 08152-2658

France: Hamamatsu Photonics France S.A.R.L.: 8, Rue du Saule Trapu, Parc du Moulin de Massy, 91882 Massy Cedex, France, Telephone: 33-(1) 69 53 71 00, Fax: 33-(1) 69 53 71 10

United Kingdom: Hamamatsu Photonics UK Limited: 2 Howard Court, 10 Tewin Road, Welwyn Garden City, Hertfordshire AL7 1BW, United Kingdom, Telephone: (44) 1707-294888, Fax: (44) 1707-325777

North Europe: Hamamatsu Photonics Norden AB: Smidesvägen 12, SE-171 41 Solna, Sweden, Telephone: (46) 8-509-031-00, Fax: (46) 8-509-031-01

Italy: Hamamatsu Photonics Italia S.R.L.: Strada della Moia, 1/E, 20020 Arese, (Milano), Italy, Telephone: (39) 02-935-81-733, Fax: (39) 02-935-81-741