

MCT photoconductive detector P3257/P3981/P2750 series

Non-cooled type and TE-cooled type suitable for long, continuous operation



Features

- Choice of spectral response (up to 12 μm)
The band gap can be adjusted by controlling the composition ratio of HgTe and CdTe. Utilizing this fact, various types are available in different spectral characteristics.
- Photoconductive element that decreases its resistance by input of infrared light
- Custom devices available
Custom devices not listed in this catalog are also available with different spectral response, active area size and number of element.
- Easy-to-use infrared detector modules with preamp available

Applications

- Radiation thermometer
- Gas analyzer
- Infrared spectrophotometer
- FTIR
- CO₂ laser monitor

Accessories (Optional)

- Heatsink for one-stage TE-cooler A3179
- Heatsink for two-stage TE-cooler A3179-01
- Heatsink for three-stage TE-cooler A3179-04
- Temperature controller C1103-05 (-25 to -75 °C)
C1103-07 (20 to -30 °C)
- Preamp C5185-01 (P3981/P2750 series)
- Infrared detector modules with preamp
P4631-10 (P3257-31)
P4631 (P3981)
P4631-04 (P2750)

General ratings / Absolute maximum ratings

Type No.	Dimensional outline/ Window material *1	Package	Cooling	Active area (mm)	Absolute maximum ratings					
					Thermistor power dissipation (mW)	TE-cooler allowable current (A)	Allowable current (mA)	Operating temperature Topr (°C)	Storage temperature Tstg (°C)	
P3257-30	①/Se	with BNC connector	Non-cooled	1 × 1	-	-	50	-40 to +60	-55 to +60	
P3257-31	②/Se	TO-8	One-stage TE-cooled		0.2	1.0	1.5			50
P3981	②/S	TO-8	Two-stage TE-cooled				3			
P3981-01	③/S	TO-66					3			
P2750-08	②/S	TO-8					6			
P2750	④/S	TO-3	Three-stage TE-cooled				0.25 × 0.25			6
P2750-06				3						

*1: Window material S : Sapphire glass
Se: ZnSe

Electrical and optical characteristics (Typ. unless otherwise noted)

Type No.	Measurement condition Element temperature T (°C)	Peak sensitivity wavelength λ_p (μm)	Cut-off wavelength λ_c (μm)	Photo sensitivity S $\lambda = \lambda_p$ *3 (V/W)	D* (500, 1200, 1) *4		D* (λ_p *3, 1200, 1)	NEP $\lambda = \lambda_p$ *3 (W/Hz ^{1/2})	Rise time tr 0 to 63 % (μs)	Dark resistance Rd (Ω)
					Min.	Typ.				
					($\text{cm} \cdot \text{Hz}^{1/2}/\text{W}$)	($\text{cm} \cdot \text{Hz}^{1/2}/\text{W}$)				
P3257-30	25	6.0	11.0	2×10^{-3}	5.0×10^5	3.0×10^6	2.0×10^5	5.0×10^{-7}	1 (ns)	30
P3257-31	0	6.5	11.5	5×10^{-3}	1.0×10^6	6.0×10^6	5.0×10^5	2.0×10^{-7}	1 (ns)	35
P3981	-30	3.6	4.6	1×10^4	2.0×10^8	2.0×10^9	5.0×10^{10}	2.0×10^{-12}	10	600
P3981-01										
P2750-08										
P2750	-60	4.8	5.5	2×10^3	5.0×10^8	3.0×10^9	2.0×10^{10}	5.0×10^{-12}	3	200
P2750-06										

*2: Photo sensitivity changes with the bias current. The values in the above table are measured with the optimum bias current.

*3: P3257-30/-31: $\lambda = 10.6 \mu\text{m}$

*4: P3257-30/-31: (800, 1200, 1)

SOLID STATE DIVISION

MCT photoconductive detector P3257/P3981/P2750 series

Spectral response

P3257-30/-31

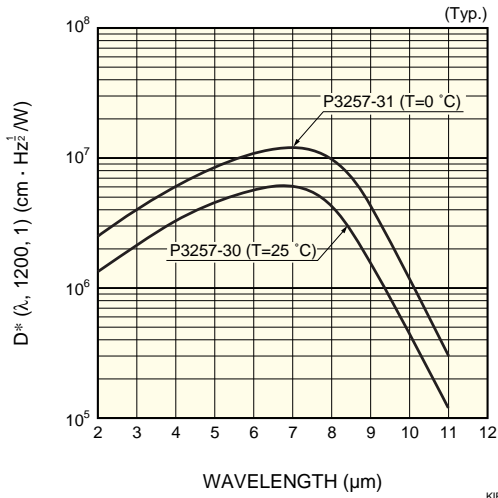

P3981/-01

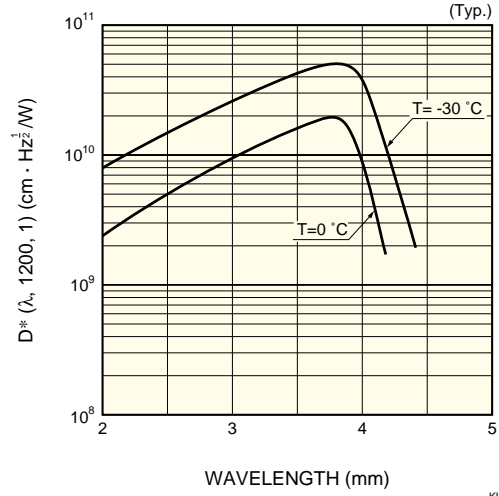

P2750-06/-08

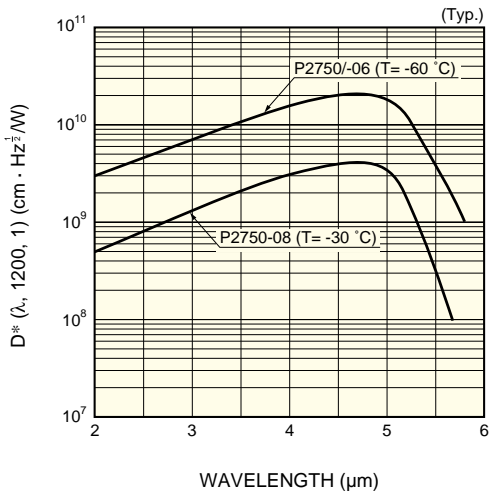

D* vs. element temperature

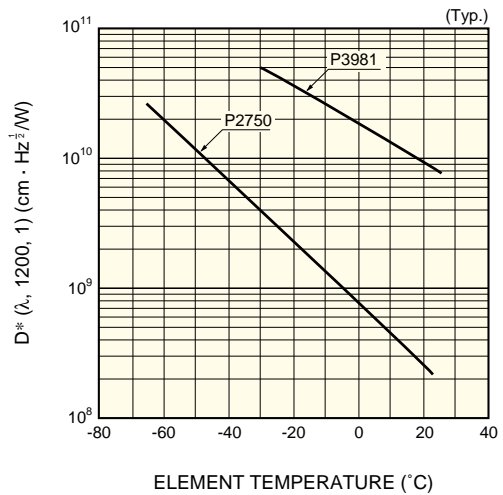

S/N vs. bias current (P2750)

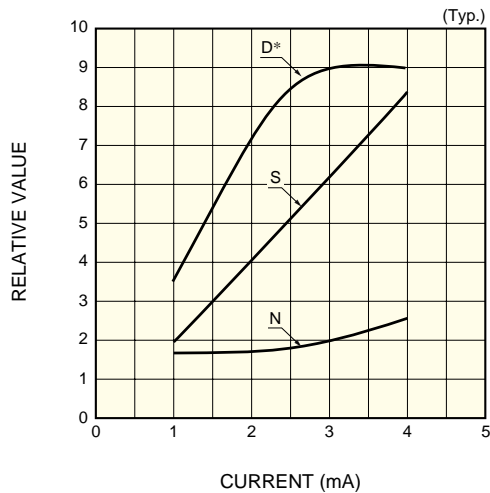

Cooling characteristics of TE-cooler

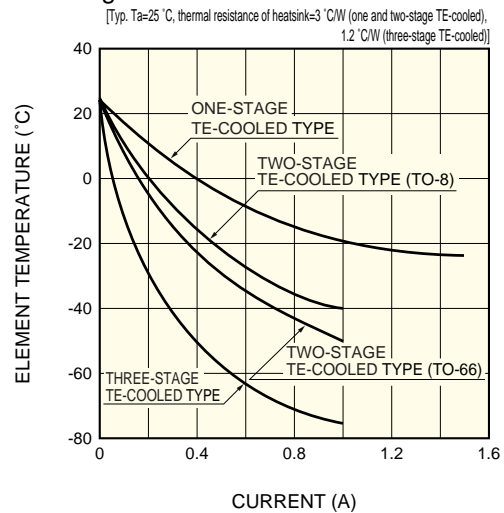

The detector must be operated in a range where the D^* becomes Max.

■ Current - voltage characteristics of TE-cooler

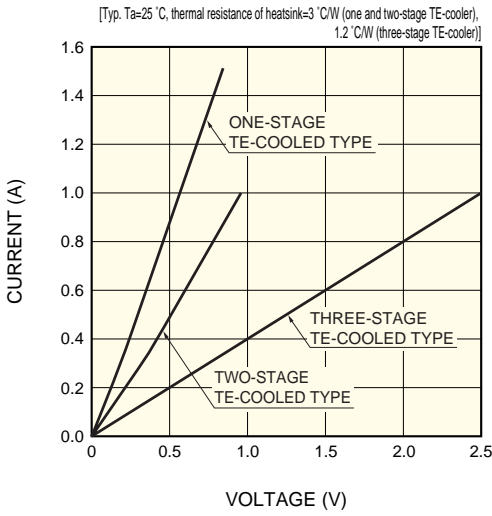

KIRD80176EB

■ Thermistor temperature characteristic

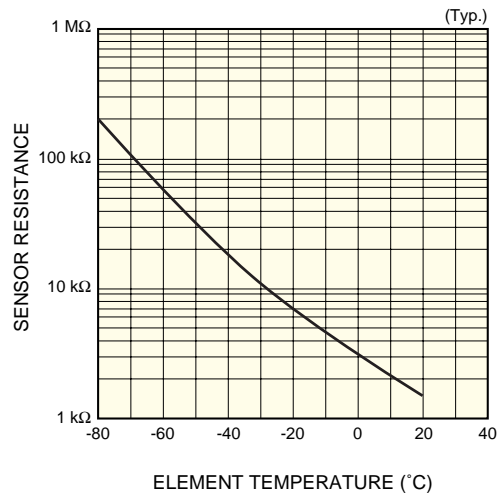

KIRD80071EB

■ Measurement circuit

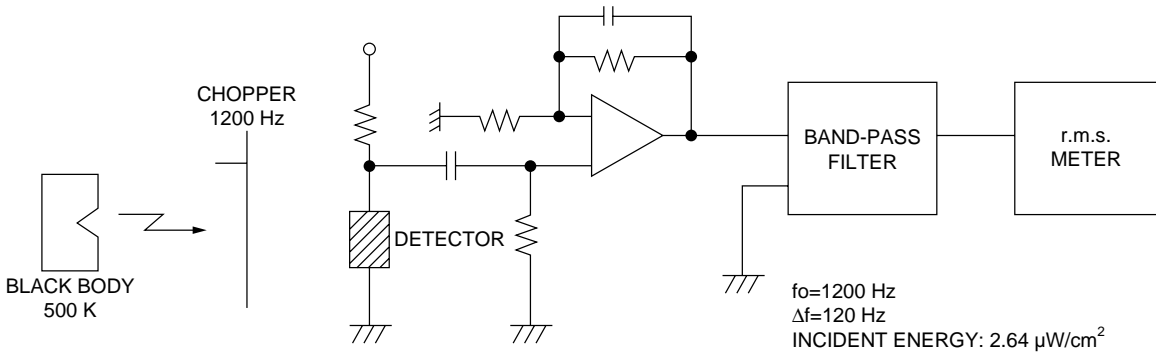

KIRD0005EA

■ Connection example (P3981)

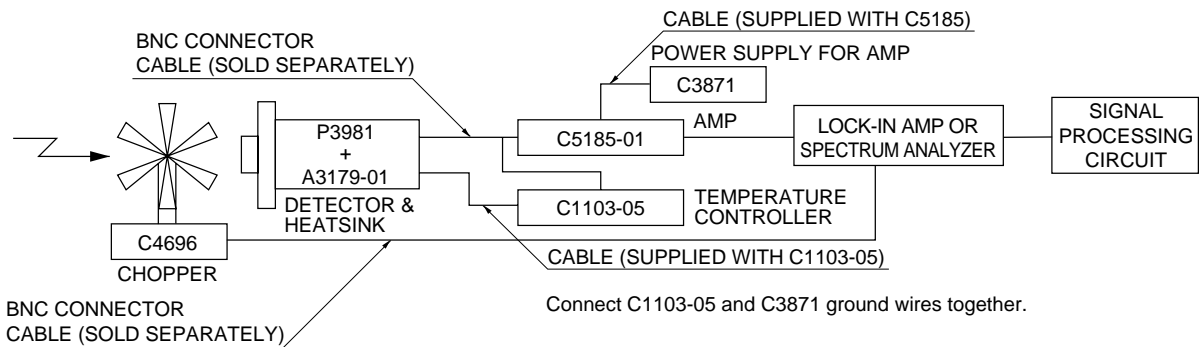

KIRD0006EA

MCT photoconductive detector P3257/P3981/P2750 series

Dimensional outlines (unit: mm)

① P3257-30

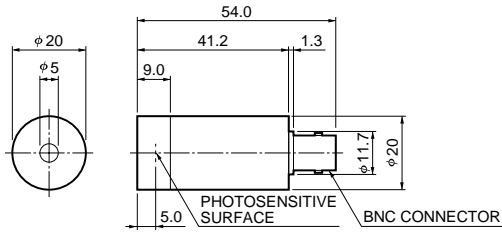

KIRDA0121EA

② P3257-31, P3981, P2750-08

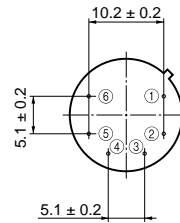
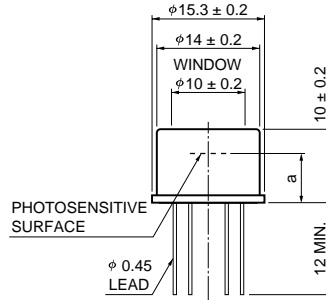

- ① DETECTOR
- ② DETECTOR
- ③ TE-COOLER (-)
- ④ TE-COOLER (+)
- ⑤ ⑥ THERMISTOR

	P3257-31	P3981, P2750-08
a	5.2 ± 0.2	6.6 ± 0.2

KIRDA0122EA

③ P3981-01

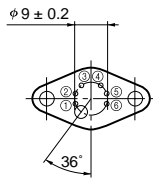
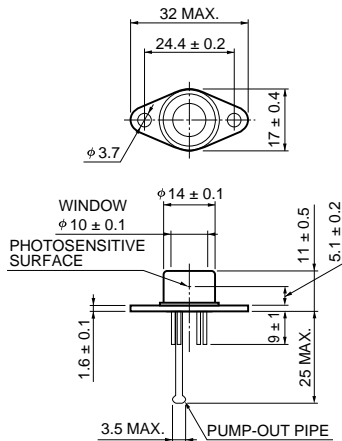

- ① ② THERMISTOR
- ③ DETECTOR
- ④ DETECTOR
- ⑤ TE-COOLER (-)
- ⑥ TE-COOLER (+)

KIRDA0123EB

④ P2750/-06

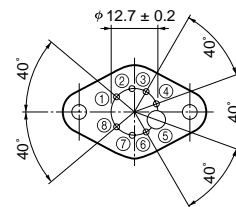
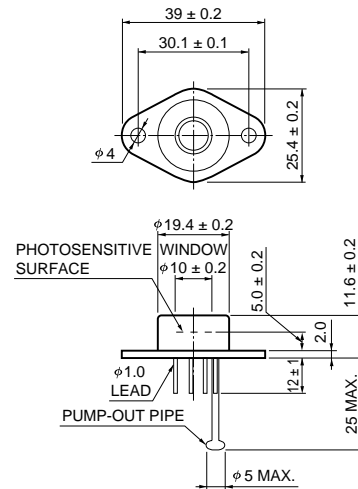

- ① TE-COOLER (+)
- ② ⑦ DETECTOR
- ③ ④ THERMISTOR
- ⑤ PUMP-OUT PIPE
- ⑥ NC
- ⑧ TE-COOLER (-)

KIRDA0045ED

HAMAMATSU

Information furnished by HAMAMATSU is believed to be reliable. However, no responsibility is assumed for possible inaccuracies or omissions. Specifications are subject to change without notice. No patent rights are granted to any of the circuits described herein. ©2003 Hamamatsu Photonics K.K.

HAMAMATSU PHOTONICS K.K., Solid State Division

1126-1 Ichino-cho, Hamamatsu City, 435-8558 Japan, Telephone: (81) 053-434-3311, Fax: (81) 053-434-5184, <http://www.hamamatsu.com>

U.S.A.: Hamamatsu Corporation: 360 Foothill Road, P.O.Box 6910, Bridgewater, N.J. 08807-0910, U.S.A., Telephone: (1) 908-231-0960, Fax: (1) 908-231-1218

Germany: Hamamatsu Photonics Deutschland GmbH: Arzbergerstr. 10, D-82211 Herrsching am Ammersee, Germany, Telephone: (49) 08152-3750, Fax: (49) 08152-2658

France: Hamamatsu Photonics France S.A.R.L.: 8, Rue du Saule Trapu, Parc du Moulin de Massy, 91882 Massy Cedex, France, Telephone: 33-(1) 69 53 71 00, Fax: 33-(1) 69 53 71 10

United Kingdom: Hamamatsu Photonics UK Limited: 2 Howard Court, 10 Tewin Road, Welwyn Garden City, Hertfordshire AL7 1BW, United Kingdom, Telephone: (44) 1707-294888, Fax: (44) 1707-325777

North Europe: Hamamatsu Photonics Norden AB: Smidesvägen 12, SE-171 41 Solna, Sweden, Telephone: (46) 8-509-031-00, Fax: (46) 8-509-031-01

Italy: Hamamatsu Photonics Italia S.R.L.: Strada della Moia, 1/E, 20020 Aresse, (Milano), Italy, Telephone: (39) 02-935-81-733, Fax: (39) 02-935-81-741