

GL6552**Low Voltage Compaander****General Descriptions**

The GL6552 is a Compaander IC, which contains two variable gain circuits configured for compressing and expanding the dynamic range, and improving of S/N ratio of audio signal. It consists of compressor, expander, Mic Amp, limiter, ALC(Automatic Level Control)and mute logic. The compressor circuit has the 2/1 ratio of input/output ratio by logarithm, and the expander circuit by logarithm. An internal, temperature stable bandgap reference provides the necessary precision voltage and current. Applications include cordless telephone and most voice RF links.

Features

- Operating Supply Voltage: 2 ~ 6 V
- Built in ALC circuit
- Built in Mute logic circuit
- Easy gain control to use external component

Absolute Maximum Ratings(Ta = 25; Ĥ)

Parameter	Symbol	Spec.	Unit	Remark
Max. Supply Voltage	V _{CC,MAX}	7	V	
Power Dissipation	P _{D,MAX}	600	mW	
Storage Temperature	T _{STG}	-55 ~+150	Ĥ	

Stress above those listed under “Absolute Maximum Rating” may cause permanent damage of device. This is stress rating only and functional operation of the device at these or any other conditions above those indicated in the operational sections of this specification is not implied. Exposure to absolute maximum rating conditions for longer periods may affect device reliability. During overload conditions (V_{IN} > V_{CC} or V_{IN} <GND), those voltage on V_{CC} pins with respect to ground must not exceed the values defined by the absolute maximum ratings.

Operating Conditions (Ta = 25; Ĥ)

Parameter	symbol	Spec.	Unit	Remark
Operating Voltage	V _{OP}	2 ~ 6	V	
Operating Temperature	T _{OP}	-20 ~ +70	Ĥ	

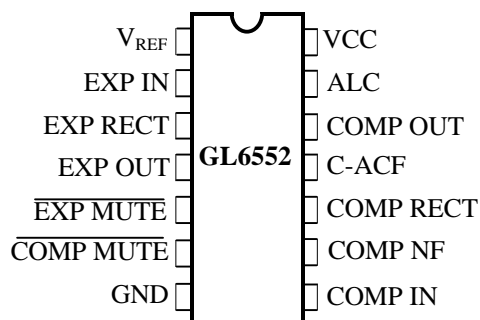
Pin Configuration

14 DIP, 14 SOP(150mil)

BLOCK DIAGRAM

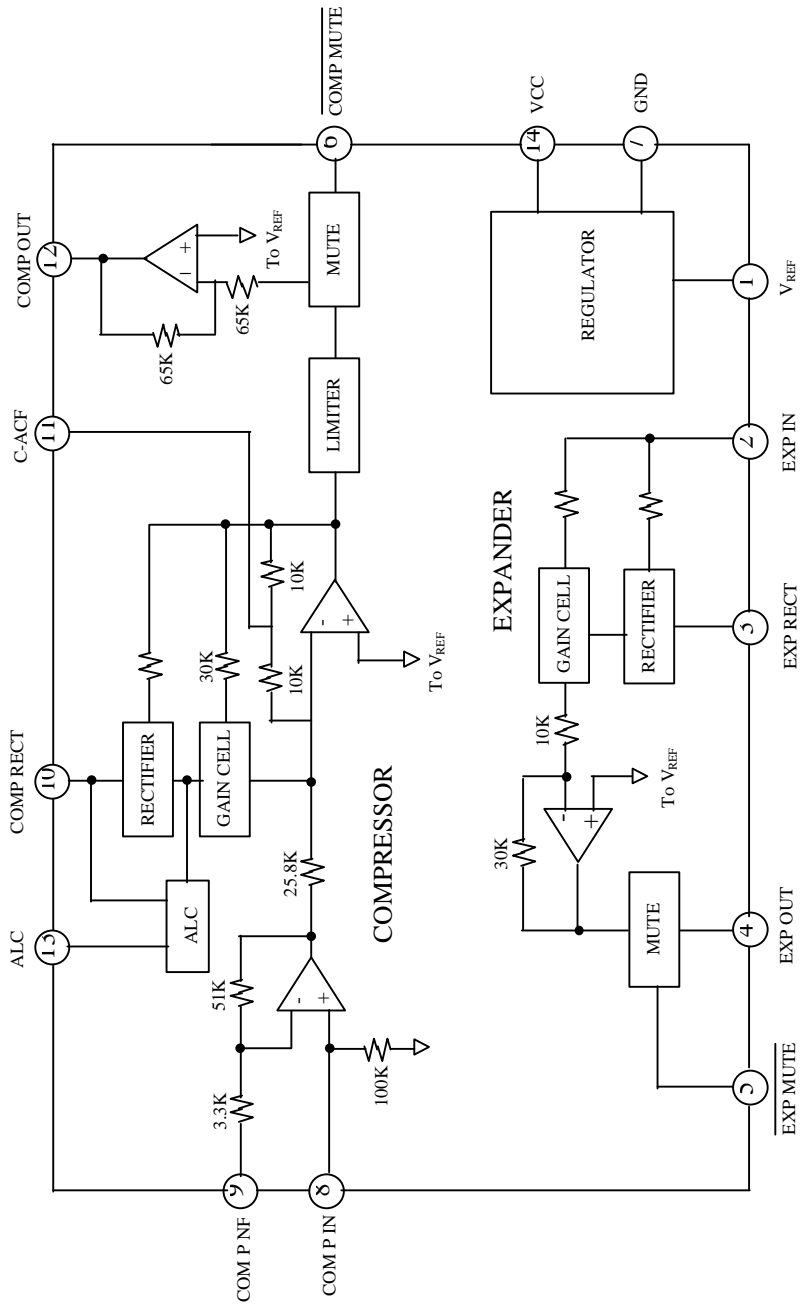

Pin Description

No.	Symbol	Function
1	V _{REF}	Output terminal of bias circuit (Band Gap of reference). It is an internal reference voltage used for supplying a constant voltage to the compressor and the expander.
2	EXP IN	Expander input terminal
3	EXP RECT	External rectifying capacitor is connected to this terminal. Attack and decay time of expander is determined by capacitor.
4	EXP OUT	Expander output terminal
5	$\overline{\text{EXP MUTE}}$	It is an expander mute terminal of a compander. “L” state – expander mute is executed. “H” state – expander is executed.
6	$\overline{\text{COMP MUTE}}$	It is an compander mute terminal of a compander. “L” state – compressor mute is executed. “H” state – compressor is executed.
7	GND	Ground terminal
8	COMP IN	Compressor Mic Amp noninverting input terminal. It is used as input terminal for voice signal.
9	COMP NF	Compressor Mic Amp inverting input terminal. It is used for determining Mic Amp gain by resistor
10	COMP RECT	External rectifying capacitor is connected to this terminal. Attack and decay time of expander is determined by capacitor.
11	C-ACF	Feedback coupling capacitor is connected to this terminal. Low cut-off frequency of compressor is determined by this capacitor.
12	COMP OUT	Compressor output terminal.
13	ALC	It is a reference voltage input terminal of ALC. ALC circuit may be turned off according to the ALC reference voltage.
14	VCC	Supply voltage terminal

Electrical Characteristics (VCC=3V, f=1KHz, Ta=25; Unless otherwise specified)

PARAMETER	SYMBOL	SPEC.			UNIT	CONDITION
		MIN.	TYP.	MAX.		
DC Electrical Characteristics						
Power Supply Current	I _{cc}	-	3.6	6	mA	No Signal
Reference voltage	V _{REF}	0.9	1	1.1	V	No Signal
Compressor part						
Standard Output Voltage	V _{OC}	240	300	340	mVrms	V _{INC} =13mVrms (=0dB)
Gain Difference	DG _{c1}	-1.0	0	1.0	dB	V _{INC} = -20dB
T.H.D	THD _c	-	0.5	1	%	V _{INC} =0dB, V _{CC} =-3V
Mute Attenuation Ratio	ATT _c	60	80	-	dB	V _{INC} =0dB
Max. Output Voltage	V _{C_{MAX}}	1.15	1.35	1.5	V _{p-p}	V _{INC} =Variable
ALC	V _{ALCO}	280	325	360	mVrms	V _{PIN13} =0.9V
Expander part						
Standard Output Voltage	V _{OE}	110	130	160	mVrms	V _{INE} =180mVrms (=0dB)
Gain Difference	DG _{E1}	-0.5	0	0.5	dB	V _{INE} =-10dB
	DG _{E1}	-1.0	0	1.0	dB	V _{INE} =-20dB
T.H.D	THD _E	-	0.5	1.5	%	V _{INE} =0dB
Mute Attenuation Ratio	ATT _E	60	85	-	dB	V _{INE} =0dB
Max. Output Voltage	V _{EMAX}	500	600	-	mVrms	V _{INE} =Variable

Test Circuit

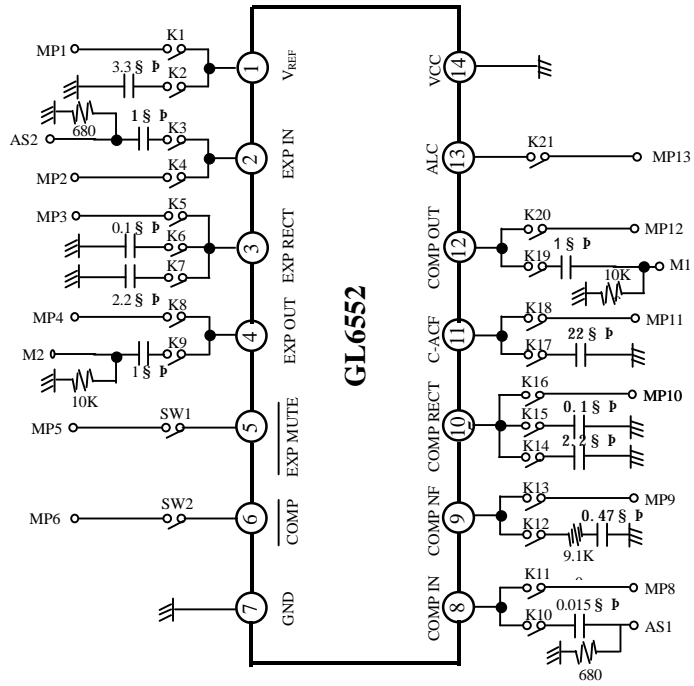

Application Circuit

