

HL14104

LCD Driver

Hyundai Electronics Industries

System IC Division

Contents

- 1. General Description**
- 2. Features**
- 3. Block Diagram**
- 4. Pin Diagram**
- 5. Pin Description**
- 6. Serial I/O Data Format**
- 7. Registers**
- 8. Key Scan Function**
- 9. LCD Function**
- 10. Power On Reset**
- 11. Power Down Mode**
- 12. Oscillator Port**
- 13. Electrical Characteristics**
- 14. Application**

1. General Description

The HL14104 is 1/4 duty LCD display driver. It can drive directly maximum 164 segments. Also it has four general purpose output ports and a key scan function that accepts input from up to 30 keys.

2. Features

- LCD display 41 segments x 4 commons
 1/4 duty - 1/2 bias
 1/4 duty - 1/3 bias
- Key scan Maximum 30 keys
 Input 5 pins, Output 6 pins
- Power down mode Sleep mode and all segments off mode
- Port
 Output 4 pins
 (Including the LCD segment port)
- Serial I/O Data transfer and receive
- Power on reset Supply voltage detection (SVD)
- RC oscillator
- Package 64QFP

Package Dimensions

64QFP (14×14)

64QFP (10×10)

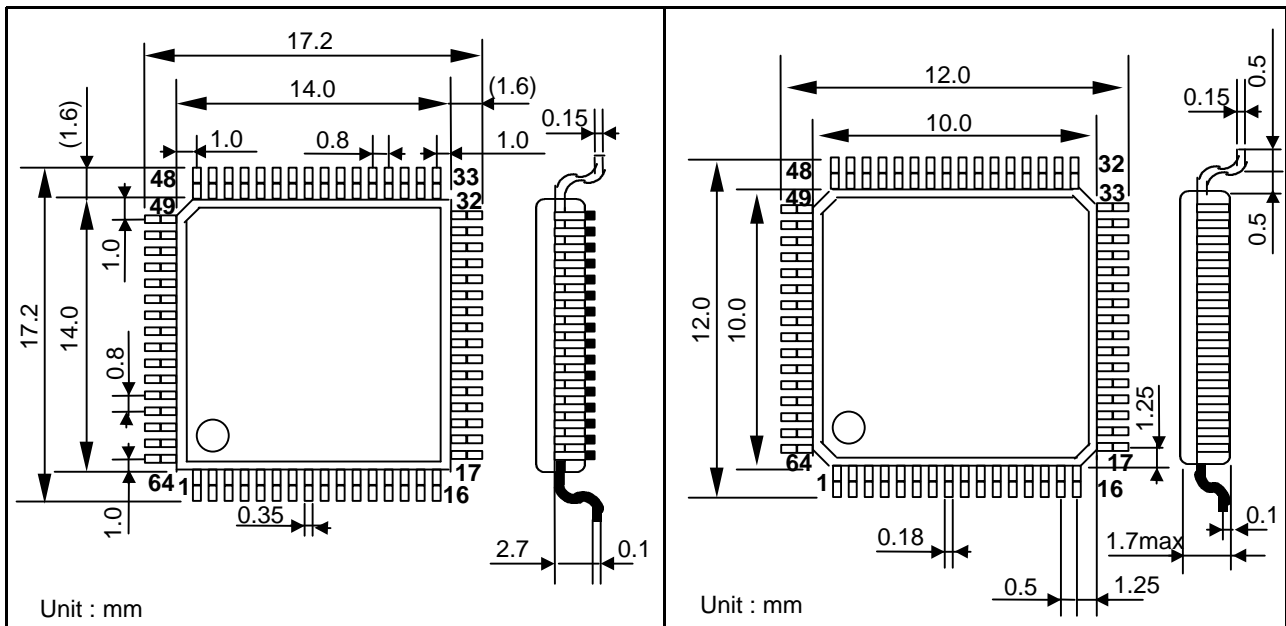

3. Block Diagram

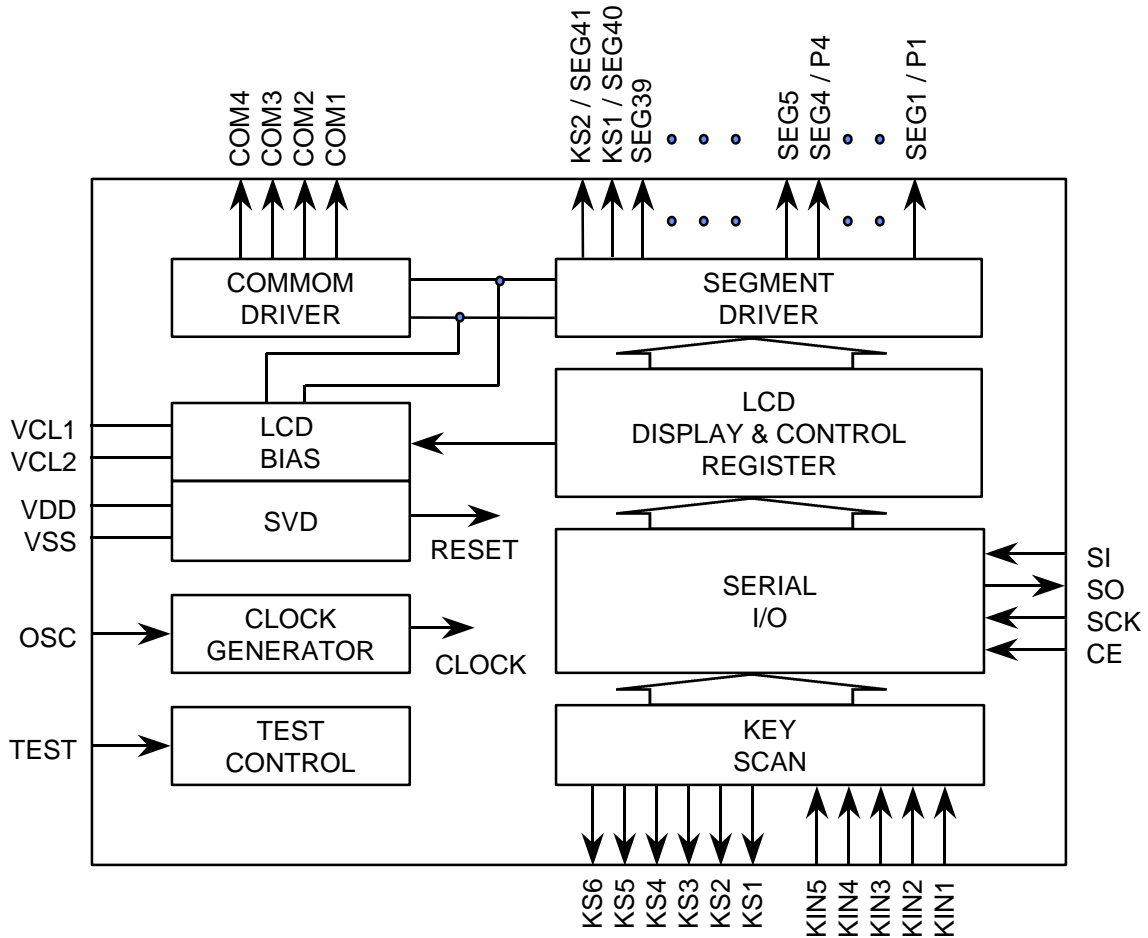

4. Pin Diagram

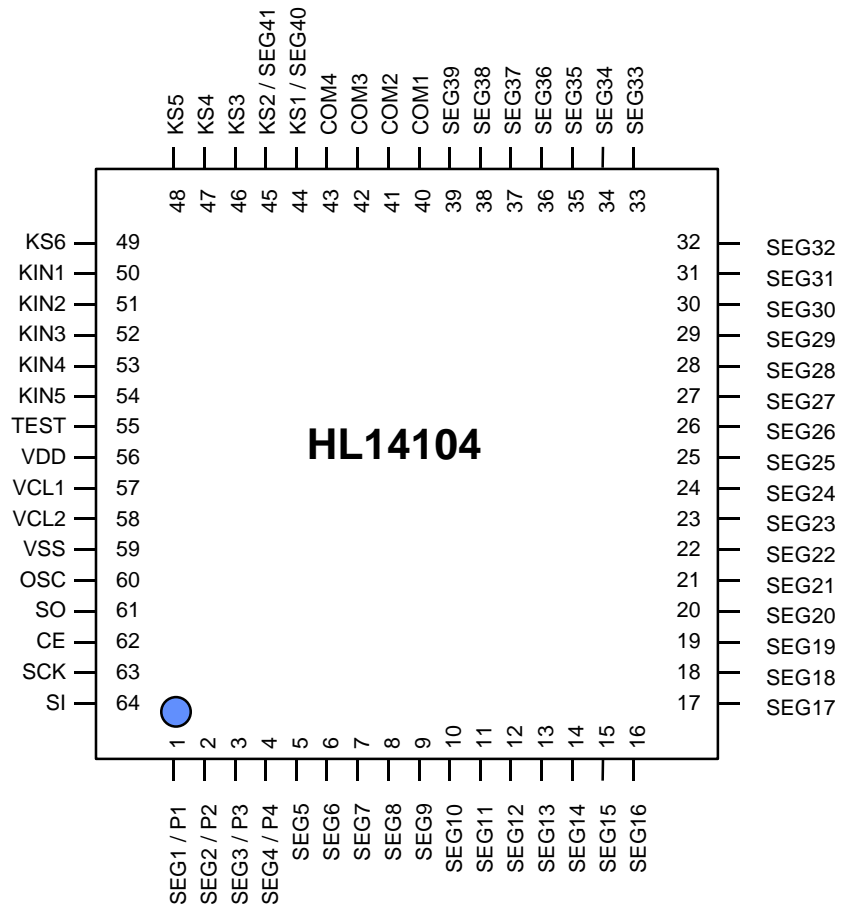

5. Pin Description

PIN Name	I/O	Pin Number	Contents
SEG[41:1]	O	41	LCD SEG Pins share P1,P2,P3 and P4
COM [4:1]	O	4	LCD Common Pins
VCL[2:1]	I	2	LCD Bias Pins
OSC	I/O	1	Oscillator Input Pin
KS[6:1]	O	6	Key Scan Output Pins
KIN[5:1]	I	5	Key Scan Input Pins
CE	I	1	Serial I/O Control Pin
SCK	I	1	Serial I/O Clock Pin
SO	O	1	Serial I/O Data Output Pin
SI	I	1	Serial I/O Data Input Pin
TEST	I	1	Test Pin. "1" Test mode , "0" Normal Mode
P[4:1]	O	4	Output Port share SEG[4:1]
VDD	I	1	Power Supply Pin
VSS	I	1	Ground Pin

6. Serial I/O Data Format

1) Writing Mode

i) SCK is stopped at the low level

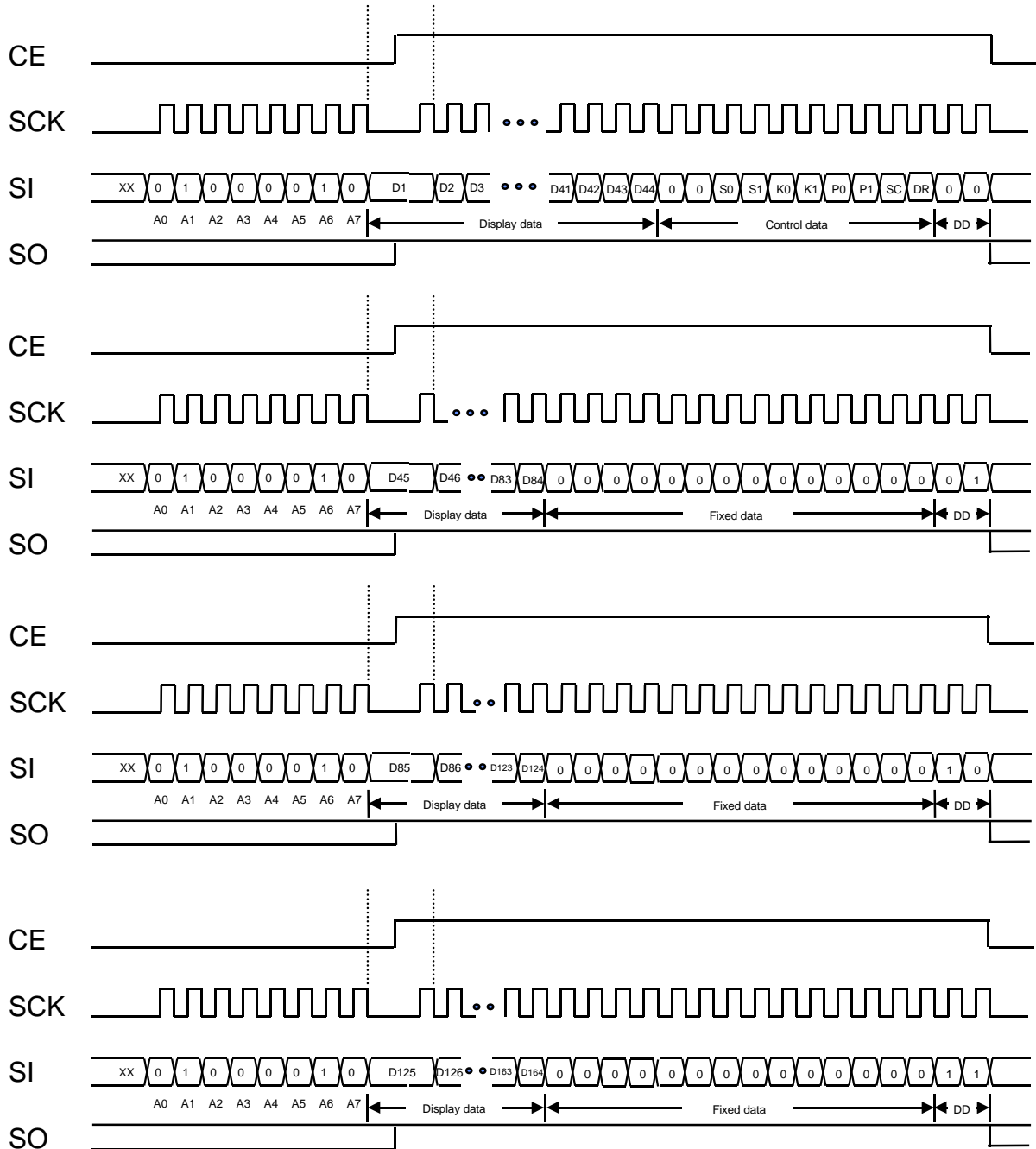

ii)SCK is stopped at the high level

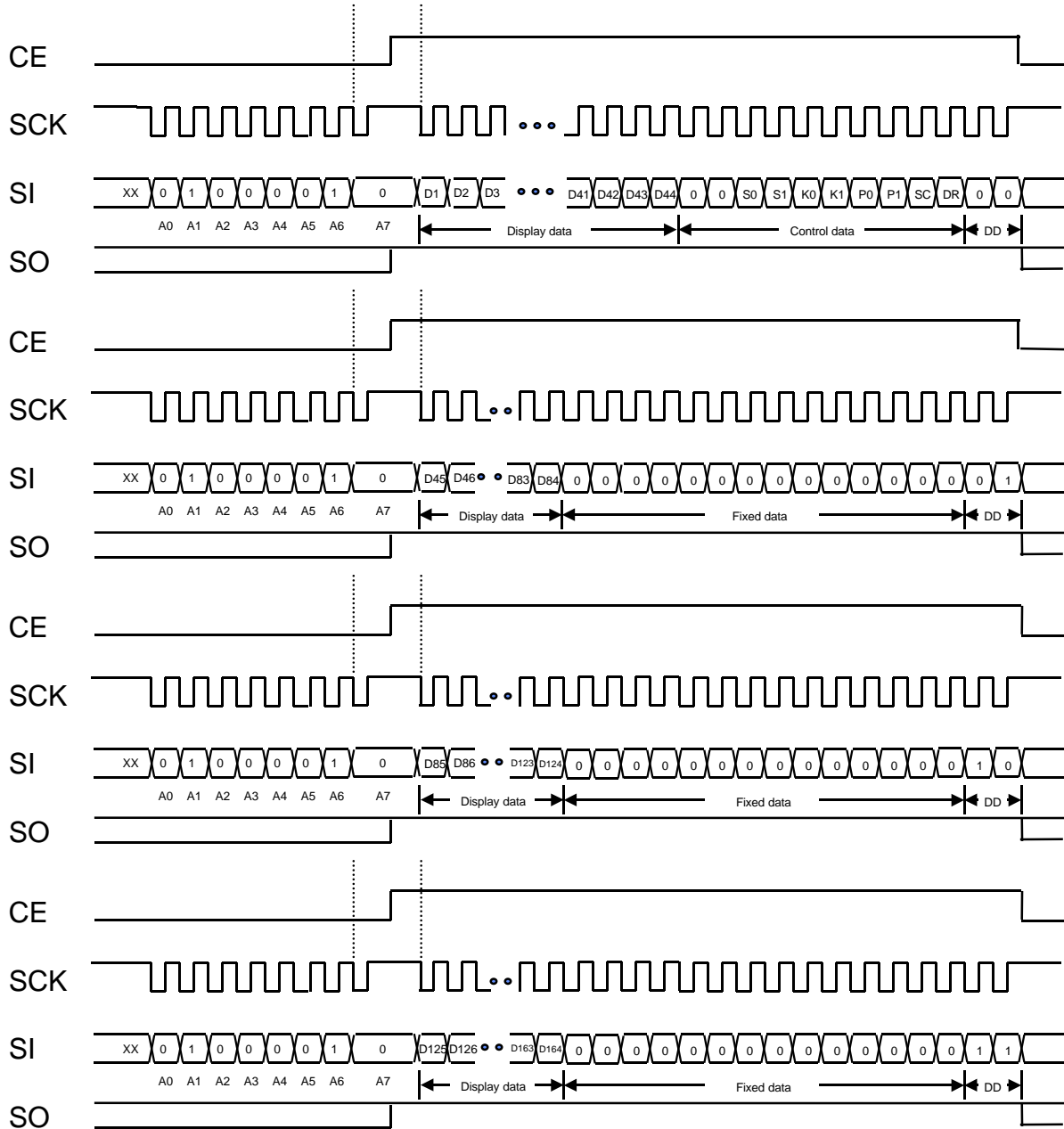

- A7~A0 : 42H address
- D164~D1 : Data of LCD display registers
- S0, S1 : Sleep control data
- K0, K1 : Key scan output / Segment output selection data
- P0, P1 : Segment output / general-purpose output port selection data
- SC : Segment on / off control data
- DR : 1/2 bias or 1/3 bias drive selection data

2) Reading Mode

i) SCK is stopped at the low level

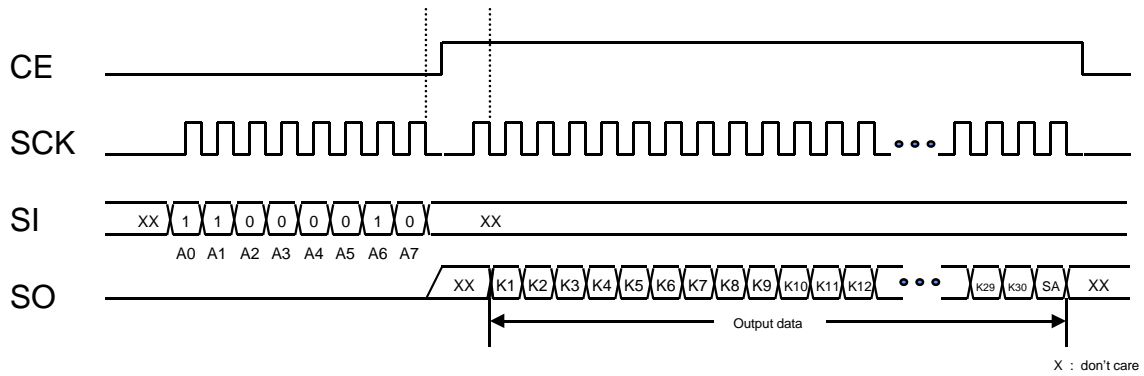

ii) SCK is stopped at the high level

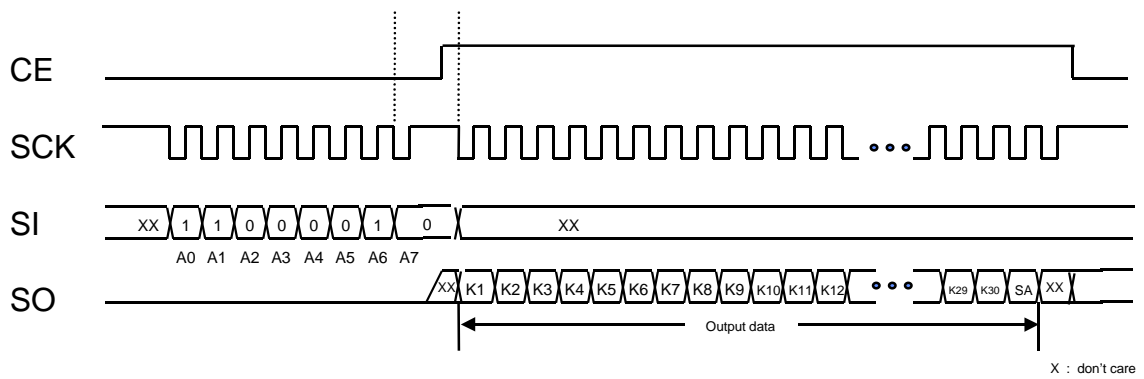

A7 ~ A0 : 43H address
 K30 ~ K1 : Key data
 SA : Sleep acknowledge

7. Registers

1) Display Registers

Output Pin	COM1	COM2	COM3	COM4
SEG1	D1	D2	D3	D4
SEG2	D5	D6	D7	D8
SEG3	D9	D10	D11	D12
SEG4	D13	D14	D15	D16
SEG5	D17	D18	D19	D20
SEG6	D21	D22	D23	D24
SEG7	D25	D26	D27	D28
SEG8	D29	D30	D31	D32
SEG9	D33	D34	D35	D36
SEG10	D37	D38	D39	D40
SEG11	D41	D42	D43	D44
SEG12	D45	D46	D47	D48
SEG13	D49	D50	D51	D52
SEG14	D53	D54	D55	D56
SEG15	D57	D58	D59	D60
SEG16	D61	D62	D63	D64
SEG17	D65	D66	D67	D68
SEG18	D69	D70	D71	D72
SEG19	D73	D74	D75	D76
SEG20	D77	D78	D79	D80
SEG21	D81	D82	D83	D84
SEG22	D85	D86	D87	D88
SEG23	D89	D90	D91	D92
SEG24	D93	D94	D95	D96
SEG25	D97	D98	D99	D100
SEG26	D101	D102	D103	D104
SEG27	D105	D106	D107	D108
SEG28	D109	D110	D111	D112
SEG29	D113	D114	D115	D116
SEG30	D117	D118	D119	D120
SEG31	D121	D122	D123	D124
SEG32	D125	D126	D127	D128
SEG33	D129	D130	D131	D132
SEG34	D133	D134	D135	D136
SEG35	D137	D138	D139	D140
SEG36	D141	D142	D143	D144
SEG37	D145	D146	D147	D148
SEG38	D149	D150	D151	D152
SEG39	D153	D154	D155	D156
SEG40	D157	D158	D159	D160
SEG41	D161	D162	D163	D164

2) Control Registers

Bias Selection Register

DR	Bias Selection
0	1/3 Bias
1	1/2 Bias

Key Scan / Segment output Selection Register

Control Data		Output Pin Status		Maximum number of Input Pins
K0	K1	KS1/SEG40	KS2/SEG41	
0	0	KS1	KS2	30
0	1	SEG40	KS2	25
1	X	SEG40	SEG41	20

Port Mode Register

Control Data		Output Pin Status			
P0	P1	SEG1/ P1	SEG2/ P2	SEG3/ P3	SEG4/ P4
0	0	SEG1	SEG2	SEG3	SEG4
0	1	P1	P2	SEG3	SEG4
1	0	P1	P2	P3	SEG4
1	1	P1	P2	P3	P4

Port Data Register

Output Pin	Port Data Register
SEG1 / P1	D1
SEG2 / P2	D5
SEG3 / P3	D9
SEG4 / P4	D13

Sleep Mode Control Register

Control Data		Mode	OSC Oscillator	SEG / COMMON Output	Output Pin Status					
S0	S1				KS1	KS2	KS3	KS4	KS5	KS6
0	0	Normal	Operating	Operating	H	H	H	H	H	H
0	1	Sleep	Stopped	L	L	L	L	L	L	H
1	0	Sleep	Stopped	L	L	L	L	L	H	H
1	1	Sleep	Stopped	L	H	H	H	H	H	H

Display On/Off Control Register

Control Data	Display Status
SC	SEG1 ~ SEG41
0	On
1	Off

Key Scan Data & Sleep Acknowledge Read

ADDRESS	Read Data
43H	K1 ~ K30, SA

	KIN1	KIN2	KIN3	KIN4	KIN5
KS1 / SEG40	K1	K2	K3	K4	K5
KS2 / SEG41	K6	K7	K8	K9	K10
KS3	K11	K12	K13	K14	K15
KS4	K16	K17	K18	K19	K20
KS5	K21	K22	K23	K24	K25
KS6	K26	K27	K28	K29	K30

8. Key Scan Function

1) Key Scan Timing

The key scan period is 384T. The HL14104 scans the key twice and determines that a key has been pressed when the key data agrees. It outputs a key data read request 800T after starting a key scan. If the key data does not agree and a key was pressed at that point, it scans the key again. Thus the HL14104 cannot detect a key press shorter than 800T.

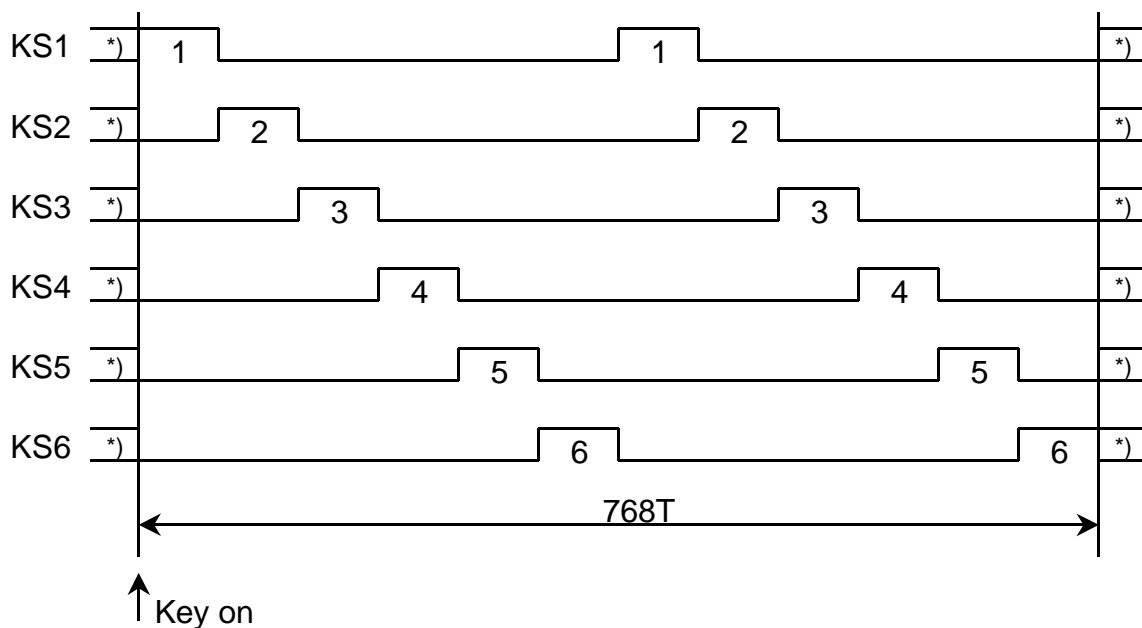

*) In sleep mode the high / low state of these pins is determined by the S0,S1 bits in the control data. Key scan output signals are not output from pins that are set low.

2) In normal mode

- The pins KS1 to KS6 are set high.
- When a key is pressed a key scan is started and the keys are scanned until all keys are released. Multiple key presses are recognized by determining whether multiple key data bits are set.
- If a key is pressed for longer than 800T (where $T=1/f_{osc}$) the HL14104 outputs a key data read request (a low level on SO pin) to the controller. The controller acknowledges this request and reads the key data. However, if CE is high during a serial data transfer, SO will be set high.
- After the controller reads the key data, the key data read requests is cleared (SO pin is set high) and the HL14104 performs another key scan. Also note that SO pin, being an open-drain output, requires a pull-up resistor.

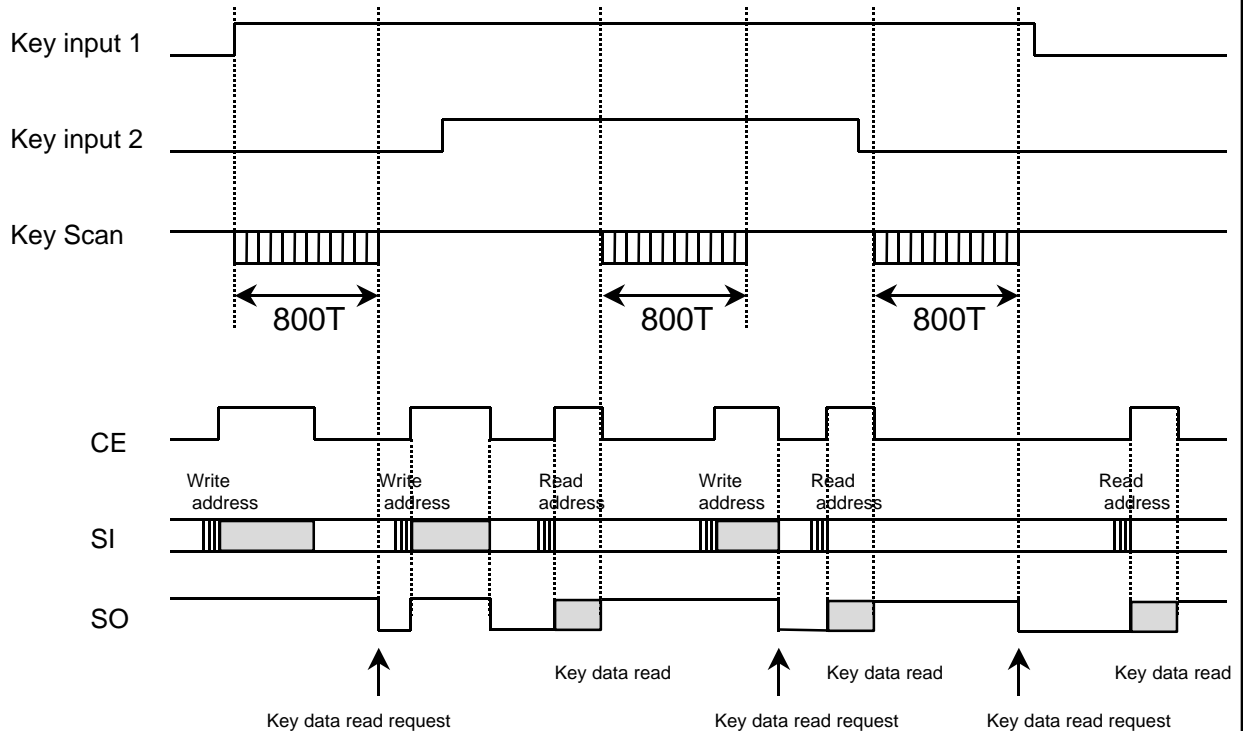

3) In sleep mode

- The pins KS1 to KS6 are set to high or low by the S0 and S1 bits in the sleep mode control register.
- If a key on one of the lines corresponding to a KS1 to KS6 pin which is set high is pressed, the oscillator on the OSC pin is started and a key scan is performed. Keys are scanned until all keys are released. Multiple key presses are recognized by determining whether multiple key data bits are set.
- If a key is pressed for longer than 800T (where $T=1/f_{osc}$) the HL14104 outputs a key data read request (a low level on SO) to the controller. The controller acknowledges this request and reads the key data. However, if CE is high during a serial data transfer, SO will be set high.
- After the controller reads the key data, the key data read request is cleared (SO is set high) and the HL14104 performs another key scan. However this does not clear sleep mode. Also note that SO, being an open-drain output, requires a pull-up resistor (between 1 and 10 K).
- Sleep mode key scan example
Example : S0 = 0, S1 = 1 (sleep with only KS6 high)

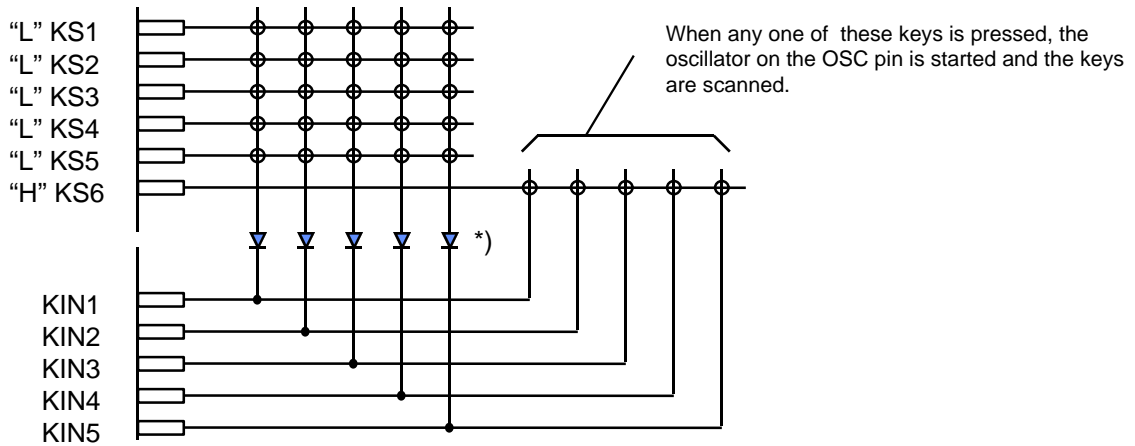

*) These diodes are required to reliably recognize multiple key presses on the KS6 line when sleep mode state with only KS6 high, as in the above example. That is, these diodes prevent incorrect operation due to sneak currents in the KS6 key scan output signal when keys on the KS1 to KS5 lines are pressed at the same time.

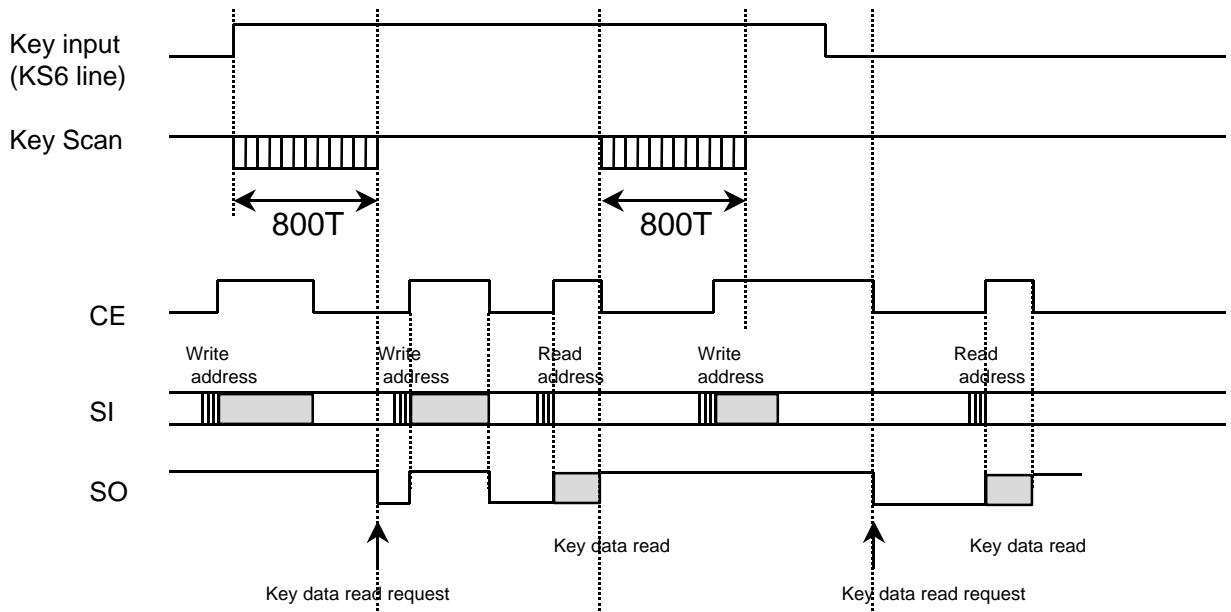

Multiple Key Presses

Although the HL14104 is capable of key scanning without inserting diodes for dual key presses, triple key presses on the KIN1 to KIN5 input pin lines, or multiple key presses on the KS1 to KS6 output pin lines, multiple presses other than these cases may result in keys that were not pressed recognized as having been pressed. Therefore, a diode must be inserted in series with each key. Application that do not recognize multiple key presses of threes or keys should check the key data for three or more 1 bits and ignore such data.

9. LCD Display Function

1) 1/4 Duty 1/2 Bias Waveforms

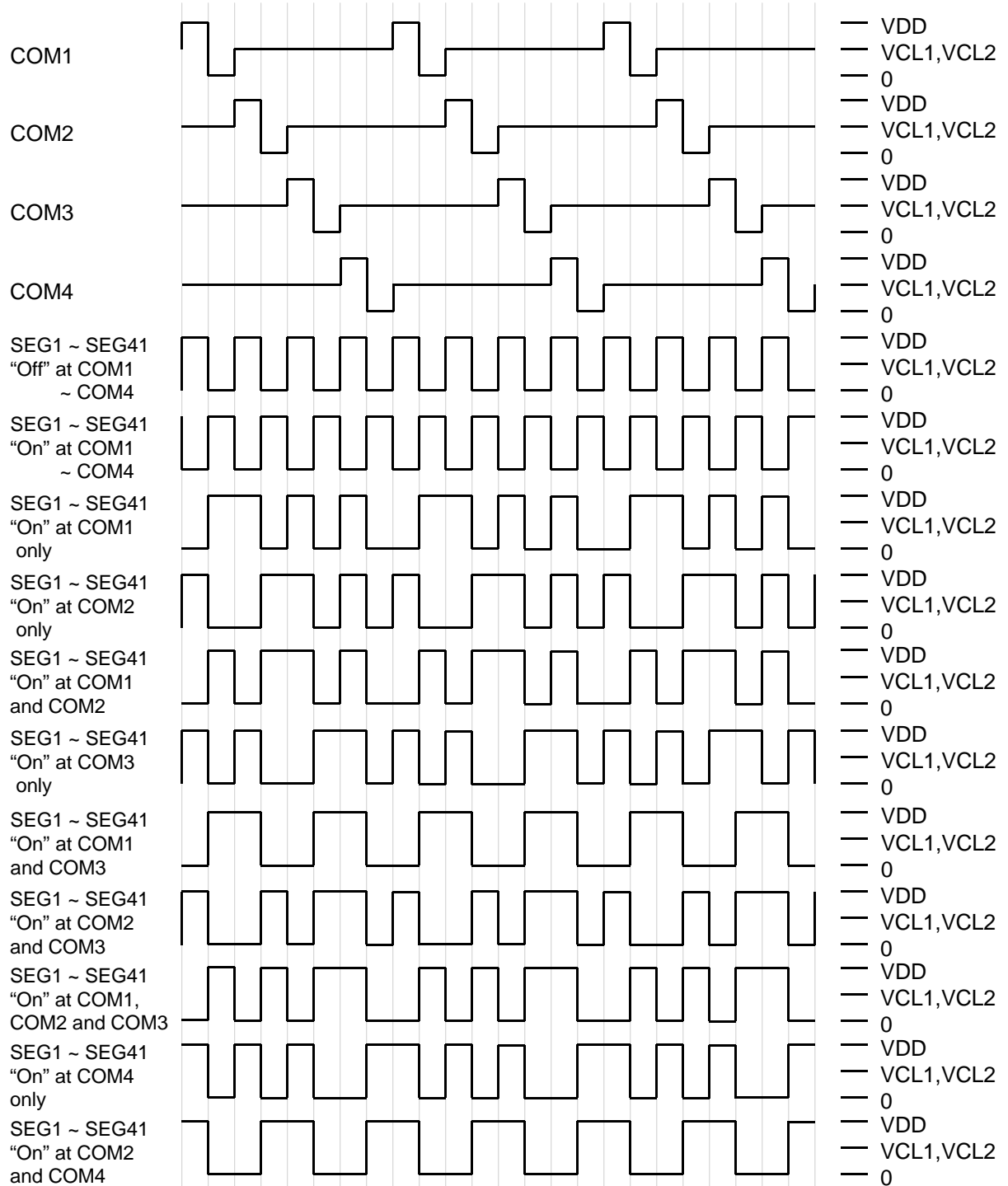

2) 1/4 Duty 1/3 Bias Waveforms

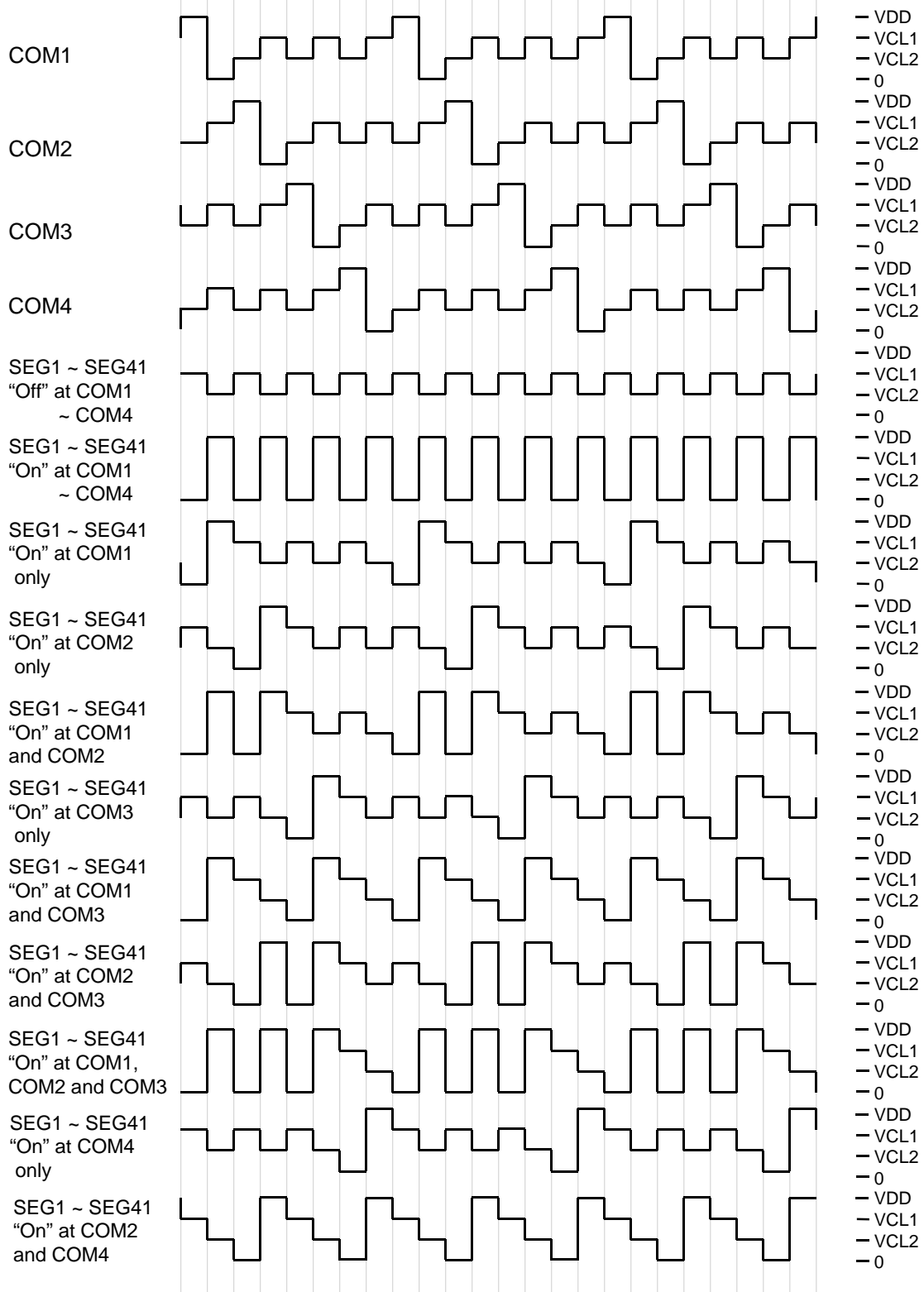

10. Power On Reset
1) Supply Voltage Detection (SVD)

The SVD generates an output signal and results the system when power is first applied and when the voltage drops. When the power supply voltage is less than or equal to the power down detection voltage, which is 2.0V, typical. To assure that this function operates reliably, a capacitor must be added to the power supply voltage Vdd rise time when power is first applied and the power supply voltage Vdd fall time when the voltage drops are both at least 1ms.

2) System Reset

If at least 1ms is assured as the supply voltage Vdd rise time when power is applied, a system reset will be applied by the SVD output signal when the supply voltage is brought up. If at least 1ms is assured as the supply voltage Vdd fall time when power drops, a system reset will be applied in the same manner by the SVD output signal when the supply voltage is lowered.

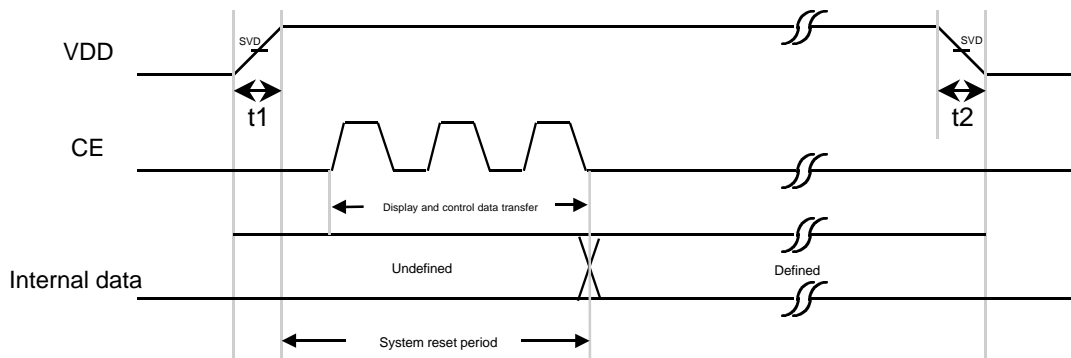

Power supply voltage Vdd rise time : $t_1 \geq 1\text{ms}$
 Power supply voltage Vdd fall time : $t_2 \geq 1\text{ms}$

3) Internal block states during the reset period

- Clock generator
Reset is applied and the base clock is stopped and OSC pin state is low.
- Common , segment drive and display data
Reset is applied and the display is turned off but display data is not cleared.
- Key scan
Reset is applied and all the key data is set to low.

4) Output pin states during the reset period

- SEG1/P1 to SEG4/P4 : Low *)
- SEG5 to SEG39 : Low
- COM1 to COM4 : Low
- KS1/SEG40, KS2/SEG41 : Low *)
- KS3 to KS5 : X **)
- KS6 : High
- SO : High ***)

*) These output pins are forcibly set to the segment output function and held low.

***) When power is first applied, these output pins are undefined until the S0 and S1 control data bits have been transferred.

****) Since this output pin is an open-drain output, a pull-up resistor of between 1 and 10 Ω is required. This pin remains high during the reset period even if a key data read operation is performed.

11. Power Down Mode

Sleep mode is set up by setting S0 or S1 in the control data to 1. The segment outputs will all go low and the common outputs will also go low, and the oscillator on the OSC pin will stop (it will be started by a key press). This reduces power dissipation. This mode is cleared by sending control data with both S0 and S1 set to 0. Note that the SEG1/P1 to SEG4/P4 outputs can be used as general purpose output ports according to the state of the P0 and P1 control data bits, even in sleep mode.

12. Oscillator Port

OSC Pin Diagram

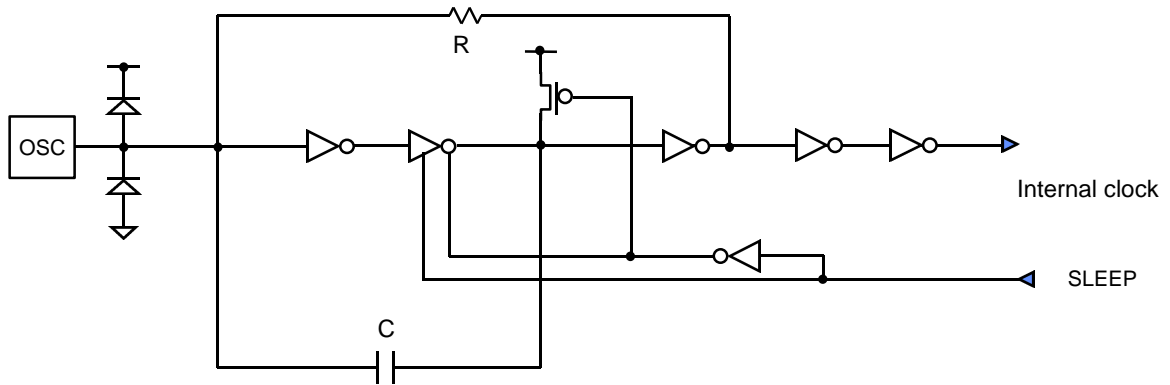

Oscillator circuit consists of internal R and C.

No Capacitor

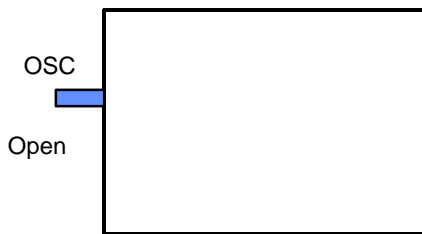

Using Capacitor

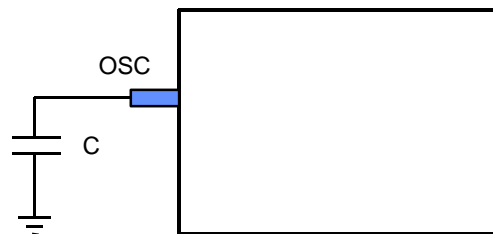

HL14104 has internal resistor and capacitor, so it can be oscillation without external capacitor. If you want to adjust the clock period then you adjust it using external capacitor.

13. Electrical Characteristics

Absolute Maximum Rating at $T_a=25$; $V_{ss} = 0V$

Parameter	Symbol	Condition	Rating	unit
Maximum supply voltage	VDD max	VDD	-0.3 to +7.0	V
Input voltage	Vin1	CE,SCK,SI	-0.3 to +7.0	V
	Vin2	OSC,KIN1 to KIN5, TEST,VCL1,2	-0.3 to VDD+0.3	V
Output voltage	Vout1	SO	-0.3 to +7.0	V
	Vout2	OSC, SEG1 to SEG41, COM1 to COM4, KS1 to KS6, P1 to P4	-0.3 to VDD+0.3	V
Output current	Iout1	SEG1 to SEG41	300	μA
	Iout2	COM1 to COM4	3	mA
	Iout3	KS1 to KS6	1	mA
	Iout4	P1 to P4	5	mA
Allowable power dissipation	Pd max	$T_a = 85$; \dot{E}	200	mW
Operating temperature	Topr		-40 to +85	$^{\circ}C$
Storage temperature	Tstg		-55 to +125	$^{\circ}C$

Recommend operating ranges at $T_a= -40$; $^{\circ}C$ to $+85$; $^{\circ}C$; $V_{ss} = 0V$

Parameter	Symbol	Condition	min	typ	max	unit
Supply voltage	VDD	VDD	4.5		6.0	V
Input voltage	VCL1	VCL1		2/3VDD	VDD	V
	VCL2	VCL2		1/3VDD	VDD	V
Input high level voltage	VIH1	CE,SCK,SI	0.8VDD		6.0	V
	VIH2	KIN1 to KIN5	0.6VDD		VDD	V
Input low level voltage	VIL	CE,SCK,SI,KIN1 to KIN5	0		0.2VDD	V
Recommended external capacitance	COSC	OSC	0		100	pF
Guaranteed oscillation range	f_{osc}	OSC	30	55	76	KHz
Data setup time	tds	SCK,SI	160			ns
Data hold time	tdh	SCK,SI	160			ns
CE wait time	tcp	CE,SCK	160			ns
CE setup time	tcs	CE,SCK	160			ns
CE hold time	tch	CE,SCK	160			ns
High level clock pulse width	t0H	SCK	160			ns
Low level clock pulse width	t0L	SCK	160			ns
Rise time	tr	CE,SCK,SI		160		ns
Fall time	tf	CE,SCK,SI		160		ns
SO output delay time	tdc	SO,RPU = 4.7k Ω , CL = 10pF*			1.5	μs
SO rise time	tdr	SO,RPU = 4.7k Ω , CL = 10pF*			1.5	μs

Note : *. Since SO is an open-drain output, these values depend on the resistance of the pull-up resistor RPU and load capacitance CL .

Electrical Characteristics for the Allowable Operating Ranges

Parameter	Symbol	Condition	min	typ	max	unit
Hysteresis	VH	CE,SCK,SI		0.1VDD		V
Supply voltage detection	SVD		1.5	2.0	3.0	V
Input high level current	I _{IH}	CE,SCK,SI : V _I = 6.0V			5.0	μA
Input low level current	I _{IL}	CE,SCK,SI : V _I = 0V	-5.0			μA
Input floating voltage	VIF	KIN1 to KIN5			0.05VDD	V
Pull-down resistance	RPD	KIN1 to KIN5 : VDD = 5.0V	50	100	250	kΩ
Output off leakage current	IOFFH	SO : V _O = 6.0V			6.0	μA
Output high level voltage	VOH1	KS1 to KS6 : I _O = -500μA	VDD -1.2	VDD -0.5		V
	VOH2	P1 to P4 : I _O = -1mA	VDD -1.0			V
	VOH3	SEG1 to SEG41 : I _O = -20μA	VDD -1.0			V
	VOH4	COM1 to COM4 : I _O = -100μA	VDD -1.0			V
Output low level voltage	VOL1	KS1 to KS6 : I _O = 25μA	0.2	0.5	1.5	V
	VOL2	P1 to P4 : I _O = 1mA			1.0	V
	VOL3	SEG1 to SEG41 : I _O = 20μA			1.0	V
	VOL4	COM1 to COM4 : I _O = 100μA			1.0	V
	VOL5	SO : I _O = 1 mA		0.1	0.5	V
Output middle level voltage*	VMID1	COM1 to COM4 : 1/2 bias, I _O = j 100μA	1/2 VDD -1.0		1/2VDD +1.0	V
	VMID2	SEG1 to SEG41 : 1/3 bias, I _O = j 20μA	2/3VDD -1.0		2/3VDD +1.0	V
	VMID3	SEG1 to SEG41 : 1/3 bias, I _O = j 20μA	1/3VDD -1.0		1/3VDD +1.0	V
	VMID4	COM1 to COM4 : 1/3 bias, I _O = j 100μA	2/3VDD -1.0		2/3VDD +1.0	V
	VMID5	COM1 to COM4 : 1/3 bias, I _O = j 100μA	1/3VDD -1.0		1/3VDD +1.0	V
Oscillator frequency	f _{OSC}	OSC : C = 0	45	55	70	KHz
Current drain	IDD1	Sleep mode			100	μA
	IDD2	VDD = 6.0V, output open, 1/2 bias, f _{OSC} = 38 KHz		350	700	μA
	IDD3	VDD = 6.0V, output open, 1/3 bias, f _{OSC} = 38 KHz		300	600	μA

Note : *. Excluding the bias voltage generation divider resistor built into VCL1 and VCL2

Timing diagram of SIO

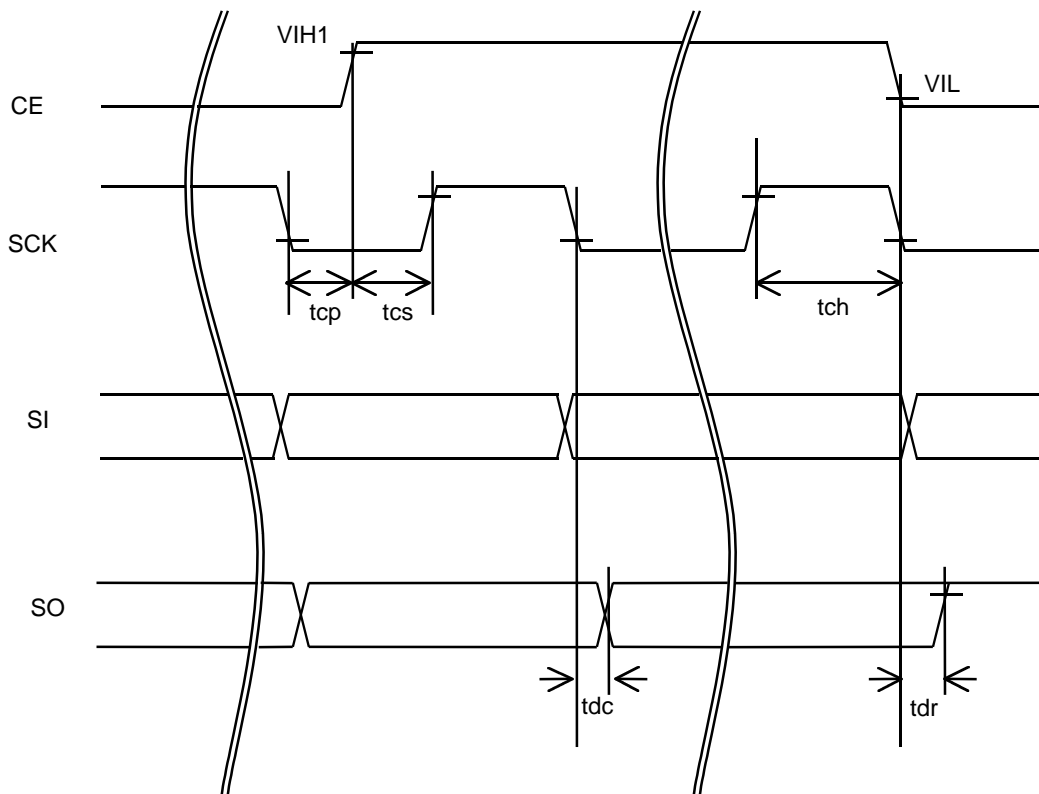
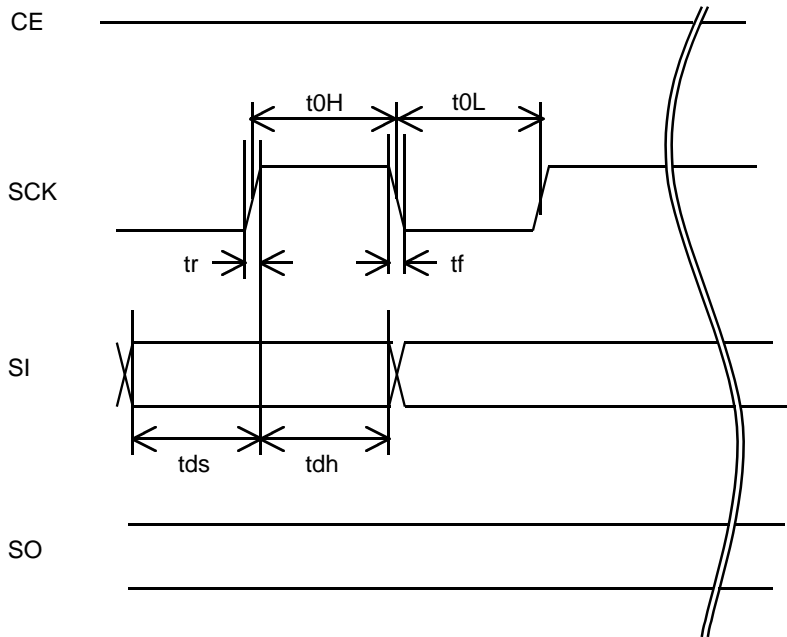

14. Application

1/2 bias (for use with normal panels)

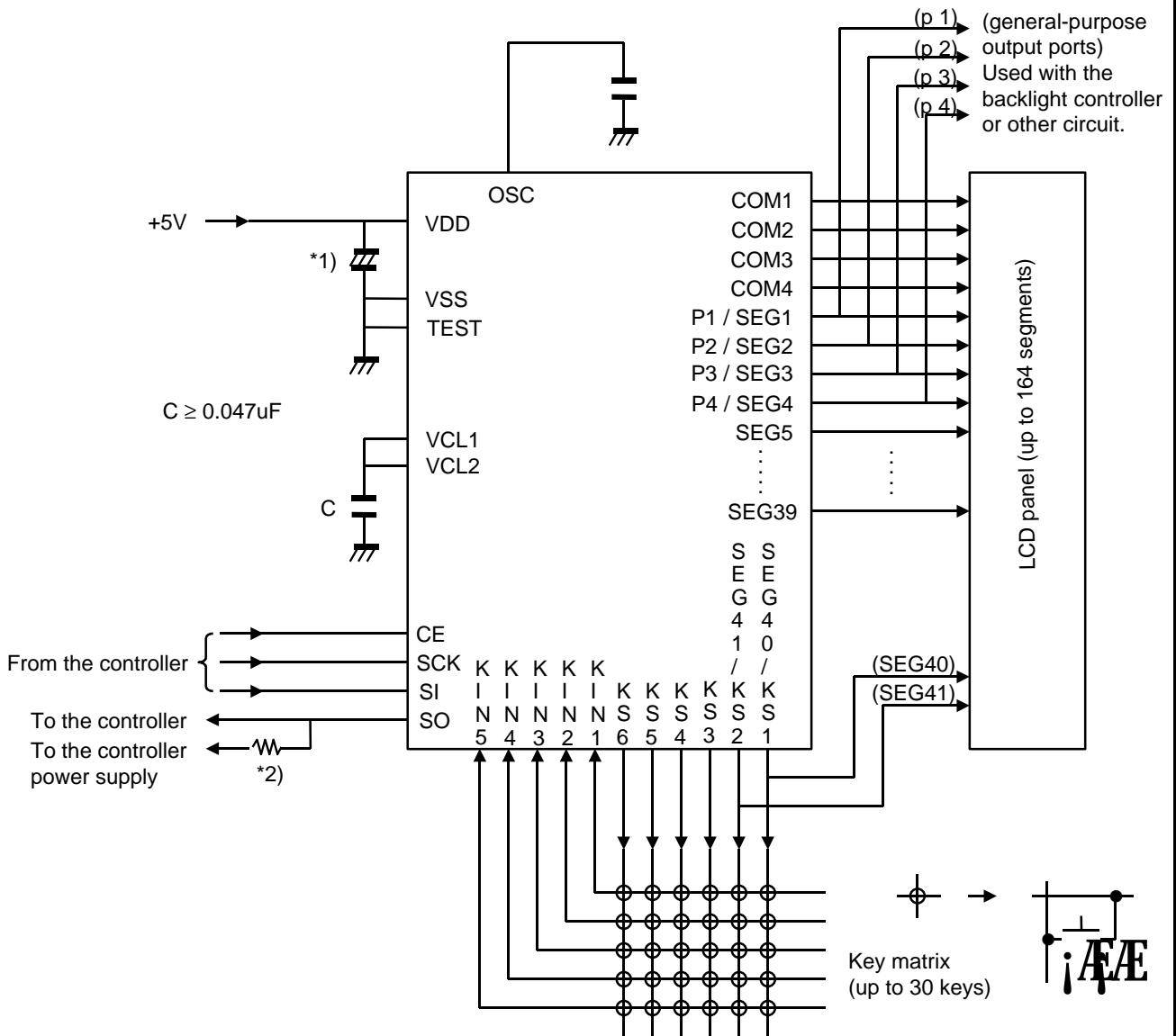

Note : *1). Add a capacitor to the power supply line so that the power supply voltage VDD rise time when power is applied and the power supply voltage VDD fall time when power drops are both at least 1 ms, as the HL14104 is reset by the SVD.

*2). The SO pin, being an open-drain output, requires a pull-up resistor, Select a resistance (between 1 to 10kΩ) appropriate for the capacitance of the external wiring so that signal waveforms are not degraded.

1/3 bias (for use with normal panels)

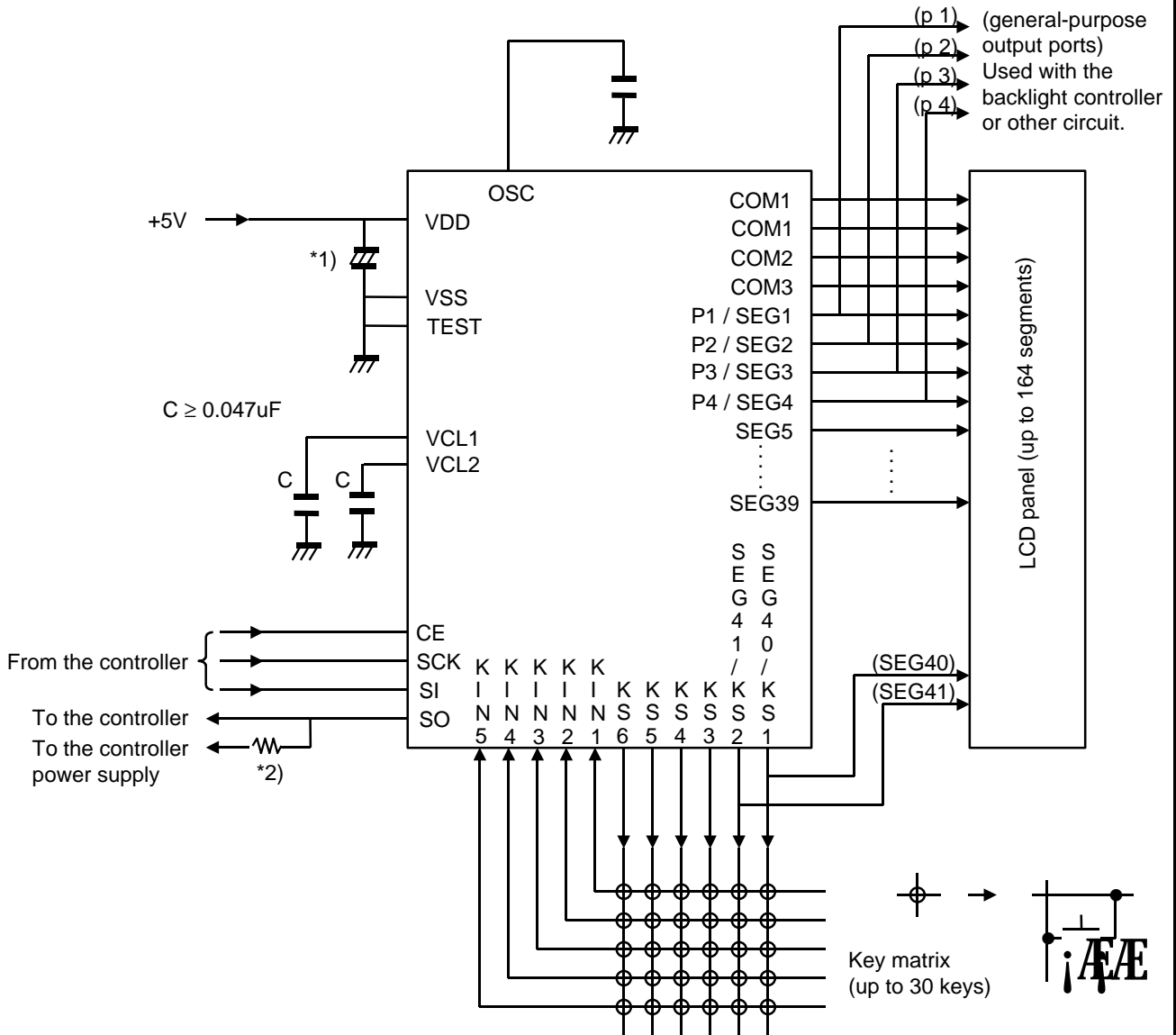

Note : *1). Add a capacitor to the power supply line so that the power supply voltage VDD rise time when power is applied and the power supply voltage VDD fall time when power drops are both at least 1 ms, as the HL14104 is reset by the SVD.

*2). The SO pin, being an open-drain output, requires a pull-up resistor, Select a resistance (between 1 to 10kΩ) appropriate for the capacitance of the external wiring so that signal waveforms are not degraded.

1/3 bias (for use with large panels)

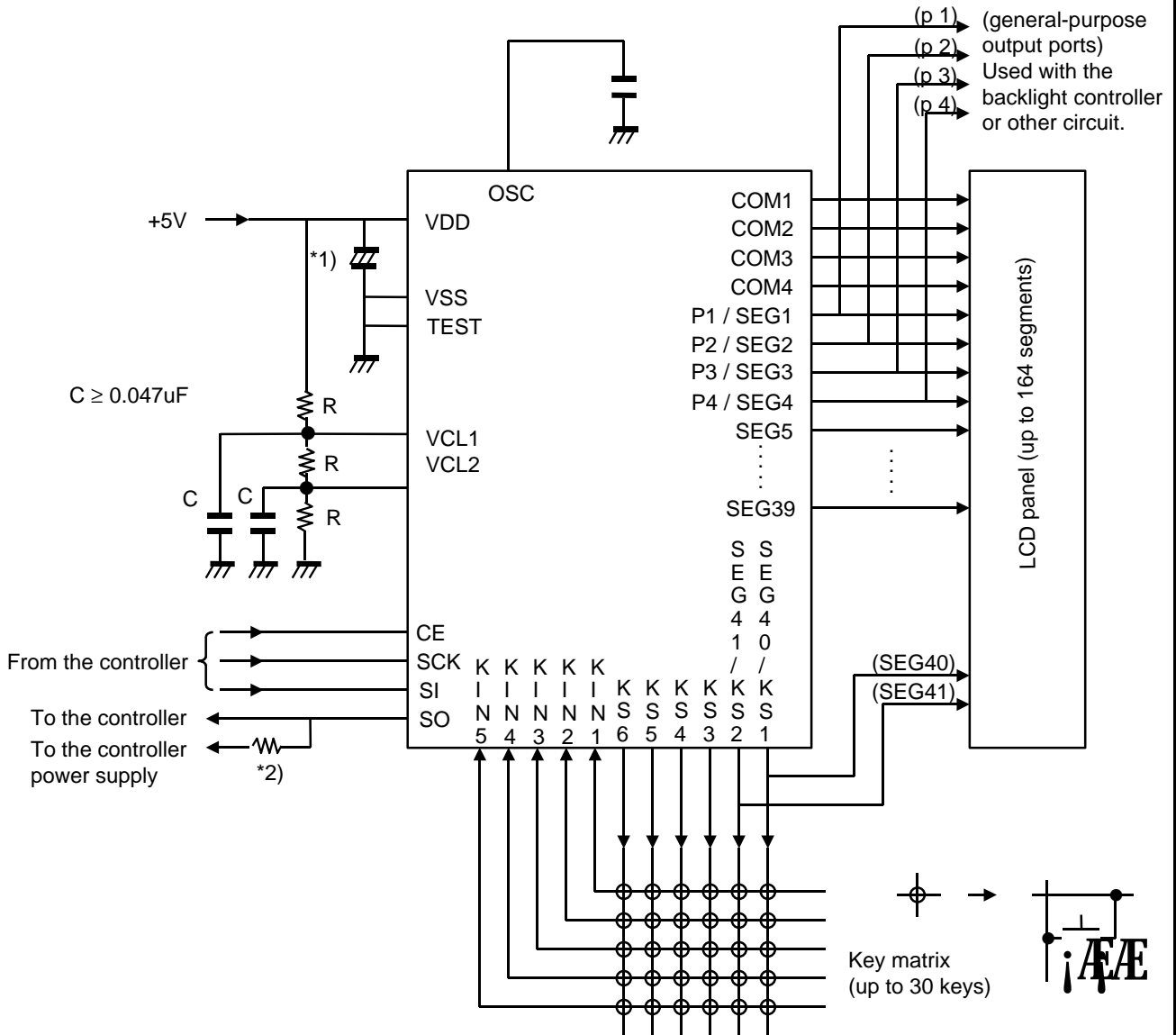

Note : *1). Add a capacitor to the power supply line so that the power supply voltage VDD rise time when power is applied and the power supply voltage VDD fall time when power drops are both at least 1 ms, as the HL14104 is reset by the SVD.

*2). The SO pin, being an open-drain output, requires a pull-up resistor, Select a resistance (between 1 to 10kΩ) appropriate for the capacitance of the external wiring so that signal waveforms are not degraded.