

# HD404719/HD404439/ HD4074719

## Description

The HD404719, HD404439, and HD4074719 are 4-bit single-chip microcomputers each incorporating five timers, two serial interfaces, an A/D converter, an input capture timer, and an output compare timer. Each also includes a 32.768-kHz oscillator and low-power dissipation modes. The HD404719 and HD404439 are mask ROM versions. The HD4074719 is a PROM version (ZTAT™ microcomputer), which can be programmed by a PROM programmer. The HD404719 has high-voltage pins, and the HD404439 has only standard pins.

## Features

- 16,384-word × 10-bit ROM (HD404719, HD404439)  
16,384-word × 10-bit PROM (HD4074719)  
ZTAT™ version is 27256-compatible
- 960-digit × 4-bit RAM
- 70 I/O pins including 36 high-voltage (40 V max.), high-current (15 mA max.) pins (except for HD404439 which has only standard pins)
- Five timer/counters
- Two 8-bit clock-synchronous serial interfaces
- 8-bit × 8-channel A/D converter
- Voltage comparator (with one input channel)
- Input capture timer/free-running counter
- 16-bit output compare timer
- Eight-level output buzzer line
- 14 interrupt sources
  - Six external sources, including three edge programmable type sources
  - Eight internal sources
- Subroutine stack up to 16 levels, including interrupts
- Four low-power dissipation modes
  - Subactive mode
  - Standby mode
  - Watch mode
  - Stop mode
- Built-in oscillator
  - Crystal or ceramic filter (external clock also enabled) main clock
  - 32.768-kHz crystal subclock
- Instruction cycle time: 0.89 μs (V<sub>CC</sub> = 3.5 to 6 V), 1.78 μs (V<sub>CC</sub> = 3.0 to 6 V)

## Ordering Information

Type	Product Name	ROM (Words)	Package
Mask ROM	HD404719FS	16,384	FP-80B
	HD404439FS		
	HD404719H	16,384	FP-80A
	HD404439H		
ZTAT™	HD4074719FS	16,384	FP-80B
	HD4074719H		

Pin Arrangement

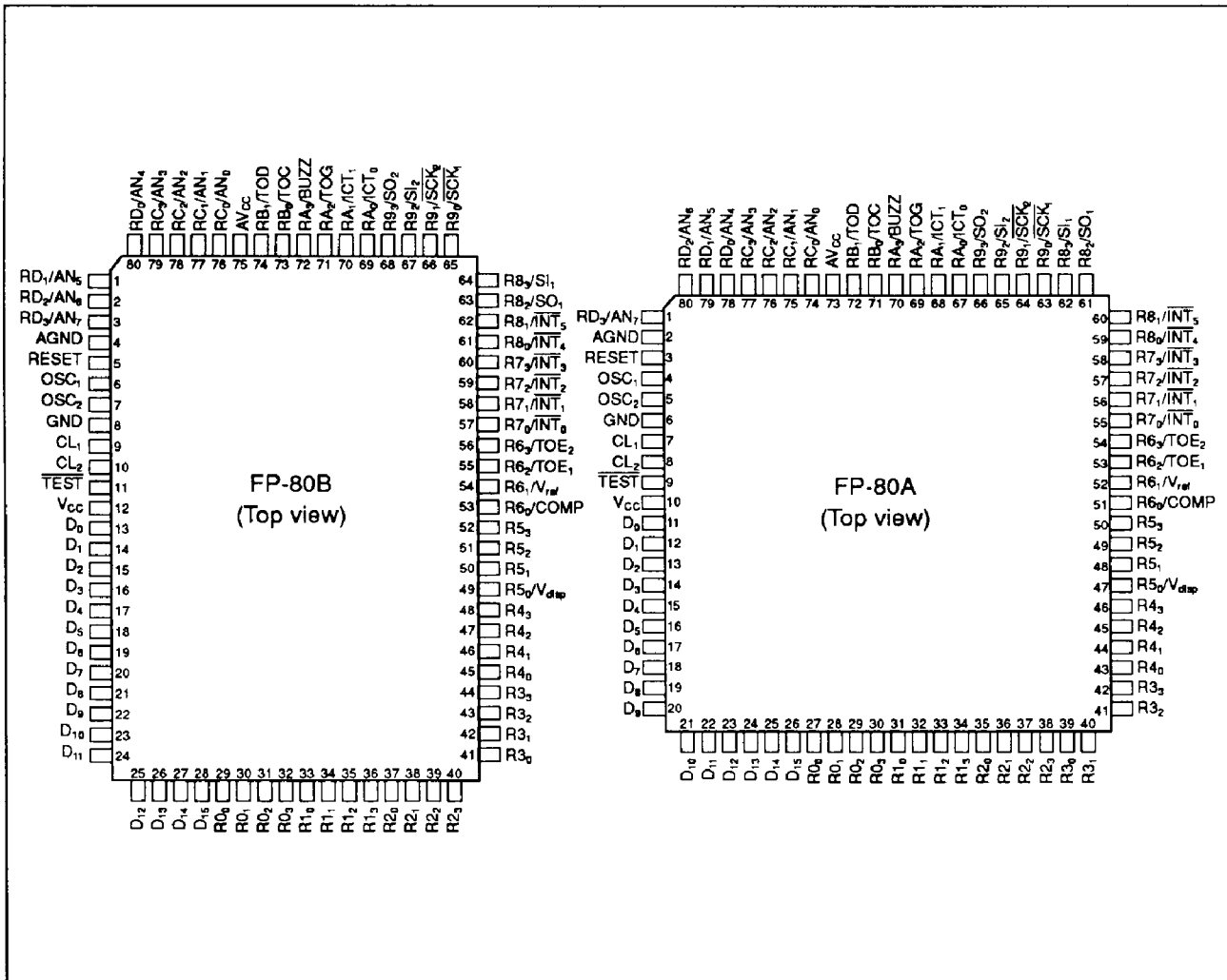

### Pin Description

Pin Number		Pin Name	Input/ Output	Pin Number		Pin Name	Input/ Output
FP-80B	FP-80A			FP-80B	FP-80A		
1	79	RD <sub>1</sub> /AN <sub>5</sub>	I	34	32	R1 <sub>1</sub>	I/O
2	80	RD <sub>2</sub> /AN <sub>6</sub>	I	35	33	R1 <sub>2</sub>	I/O
3	1	RD <sub>3</sub> /AN <sub>7</sub>	I	36	34	R1 <sub>3</sub>	I/O
4	2	AGND		37	35	R2 <sub>0</sub>	I/O
5	3	RESET	I	38	36	R2 <sub>1</sub>	I/O
6	4	OSC <sub>1</sub>	I	39	37	R2 <sub>2</sub>	I/O
7	5	OSC <sub>2</sub>	O	40	38	R2 <sub>3</sub>	I/O
8	6	GND		41	39	R3 <sub>0</sub>	I/O
9	7	CL <sub>1</sub>	I	42	40	R3 <sub>1</sub>	I/O
10	8	CL <sub>2</sub>	O	43	41	R3 <sub>2</sub>	I/O
11	9	TEST	I	44	42	R3 <sub>3</sub>	I/O
12	10	V <sub>CC</sub>		45	43	R4 <sub>0</sub>	I/O
13	11	D <sub>0</sub>	I/O	46	44	R4 <sub>1</sub>	I/O
14	12	D <sub>1</sub>	I/O	47	45	R4 <sub>2</sub>	I/O
15	13	D <sub>2</sub>	I/O	48	46	R4 <sub>3</sub>	I/O
16	14	D <sub>3</sub>	I/O	49	47	R5 <sub>0</sub> /V <sub>disp</sub>	I
17	15	D <sub>4</sub>	I/O	50	48	R5 <sub>1</sub>	I
18	16	D <sub>5</sub>	I/O	51	49	R5 <sub>2</sub>	I
19	17	D <sub>6</sub>	I/O	52	50	R5 <sub>3</sub>	I
20	18	D <sub>7</sub>	I/O	53	51	R6 <sub>0</sub> /COMP	I/O
21	19	D <sub>8</sub>	I/O	54	52	R6 <sub>1</sub> /V <sub>ref</sub>	I/O
22	20	D <sub>9</sub>	I/O	55	53	R6 <sub>2</sub> /TOE <sub>1</sub>	I/O
23	21	D <sub>10</sub>	I/O	56	54	R6 <sub>3</sub> /TOE <sub>2</sub>	I/O
24	22	D <sub>11</sub>	I/O	57	55	R7 <sub>0</sub> /INT <sub>0</sub>	I/O
25	23	D <sub>12</sub>	I/O	58	56	R7 <sub>1</sub> /INT <sub>1</sub>	I/O
26	24	D <sub>13</sub>	I/O	59	57	R7 <sub>2</sub> /INT <sub>2</sub>	I/O
27	25	D <sub>14</sub>	I/O	60	58	R7 <sub>3</sub> /INT <sub>3</sub>	I/O
28	26	D <sub>15</sub>	I/O	61	59	R8 <sub>0</sub> /INT <sub>4</sub>	I/O
29	27	R0 <sub>0</sub>	I/O	62	60	R8 <sub>1</sub> /INT <sub>5</sub>	I/O
30	28	R0 <sub>1</sub>	I/O	63	61	R8 <sub>2</sub> /SO <sub>1</sub>	I/O
31	29	R0 <sub>2</sub>	I/O	64	62	R8 <sub>3</sub> /SI <sub>1</sub>	I/O
32	30	R0 <sub>3</sub>	I/O	65	63	R9 <sub>0</sub> /SCK <sub>1</sub>	I/O
33	31	R1 <sub>0</sub>	I/O	66	64	R9 <sub>1</sub> /SCK <sub>2</sub>	I/O

Pin Description (cont)

Pin Number		Pin Name	Input/ Output	Pin Number		Pin Name	Input/ Output
FP-80B	FP-80A			FP-80B	FP-80A		
67	65	RA <sub>2</sub> /SI <sub>2</sub>	I/O	74	72	RB <sub>1</sub> /TOD	I/O
68	66	RA <sub>3</sub> /SO <sub>2</sub>	I/O	75	73	AV <sub>CC</sub>	
69	67	RA <sub>0</sub> /ICT <sub>0</sub>	I/O	76	74	RC <sub>0</sub> /AN <sub>0</sub>	I
70	68	RA <sub>1</sub> /ICT <sub>1</sub>	I/O	77	75	RC <sub>1</sub> /AN <sub>1</sub>	I
71	69	RA <sub>2</sub> /TOG	I/O	78	76	RC <sub>2</sub> /AN <sub>2</sub>	I
72	70	RA <sub>3</sub> /BUZZ	I/O	79	77	RC <sub>3</sub> /AN <sub>3</sub>	I
73	71	RB <sub>0</sub> /TOC	I/O	80	78	RD <sub>0</sub> /AN <sub>4</sub>	I

## Pin Functions

### Power Supply

**V<sub>CC</sub>**: Apply power voltage to this pin.

**GND**: Connect to ground.

**$\overline{\text{TEST}}$** : Used for test purposes only. Connect it to V<sub>CC</sub>.

**RESET**: Resets the MCU.

### Oscillators

**OSC<sub>1</sub>, OSC<sub>2</sub>**: Used as pins for the internal oscillator circuit. They can be connected to a crystal resonator or a ceramic filter resonator, or OSC<sub>1</sub> can be connected to an external oscillator circuit.

**CL<sub>1</sub>, CL<sub>2</sub>**: Used for a 32.768-kHz crystal oscillator that acts as a clock.

### Ports

**D<sub>0</sub>–D<sub>15</sub> (D Port)**: Input/output port addressable by individual bits. Each port output consists of an open-drain PMOS which enables high-voltage, high-current drive ability for its pin.

**R0–RD (R Ports)**: Input/output ports addressable in 4-bit units. R5, RC, and RD are input-only ports. The R5 to RD port pins are standard pins, but the R0 to R4 pins are high-voltage pins. Each of the R0 to R4 output pins consists of an open-drain PMOS which enables high-voltage drive ability for its pin. The R6 to RD pins are multiplexed with peripheral pins.

### Interrupts

**$\overline{\text{INT}}_0$ – $\overline{\text{INT}}_5$** : Input external interrupts to the MCU.  $\overline{\text{INT}}_0$  to  $\overline{\text{INT}}_5$  are multiplexed with R7<sub>0</sub> to R7<sub>3</sub> and R8<sub>0</sub> to R8<sub>1</sub>, respectively.

### Serial Communications Interface

**$\overline{\text{SCK}}_1$ ,  $\overline{\text{SCK}}_2$** : Input/output SCI clock pins that are multiplexed with pins R9<sub>0</sub> and R9<sub>1</sub>, respectively.

**SI<sub>1</sub>, SI<sub>2</sub>**: SCI receiving data input pins that are multiplexed with pins R8<sub>3</sub> and R9<sub>2</sub>, respectively.

**SO<sub>1</sub>, SO<sub>2</sub>**: SCI transmission data output pins that are multiplexed with pins R8<sub>2</sub> and R9<sub>3</sub>, respectively.

### Timers

**TOC, TOD**: Output variable-duty square waves. They are multiplexed with pins RB<sub>0</sub> and RB<sub>1</sub>, respectively.

**TOE<sub>1</sub>, TOE<sub>2</sub>**: Output square waves from the PWM. They are multiplexed with pins R6<sub>2</sub> and R6<sub>3</sub>, respectively.

**TOG**: Outputs a square wave specified by the output compare function. It is multiplexed with pin RA<sub>2</sub>.

### Buzzer

**Buzz**: Outputs a variable-duty square wave. It is multiplexed with RA<sub>3</sub>.

### A/D Converter

**AV<sub>CC</sub>**: V<sub>CC</sub> power supply for the A/D converter.

**AGND**: GND power supply for the A/D converter.

**AN<sub>0</sub>–AN<sub>7</sub>**: Analog data input pins for A/D conversion that are multiplexed with pins RC<sub>0</sub> to RC<sub>3</sub> and RD<sub>0</sub> to RD<sub>3</sub>, respectively.

### Comparator

**COMP**: Input pin for the comparator. It is multiplexed with pin R6<sub>0</sub>.

**V<sub>ref</sub>**: Inputs reference voltage for the analog comparator. It is multiplexed with pin R6<sub>1</sub>.

Note: The HD404439 has only standard pins.

Block Diagram

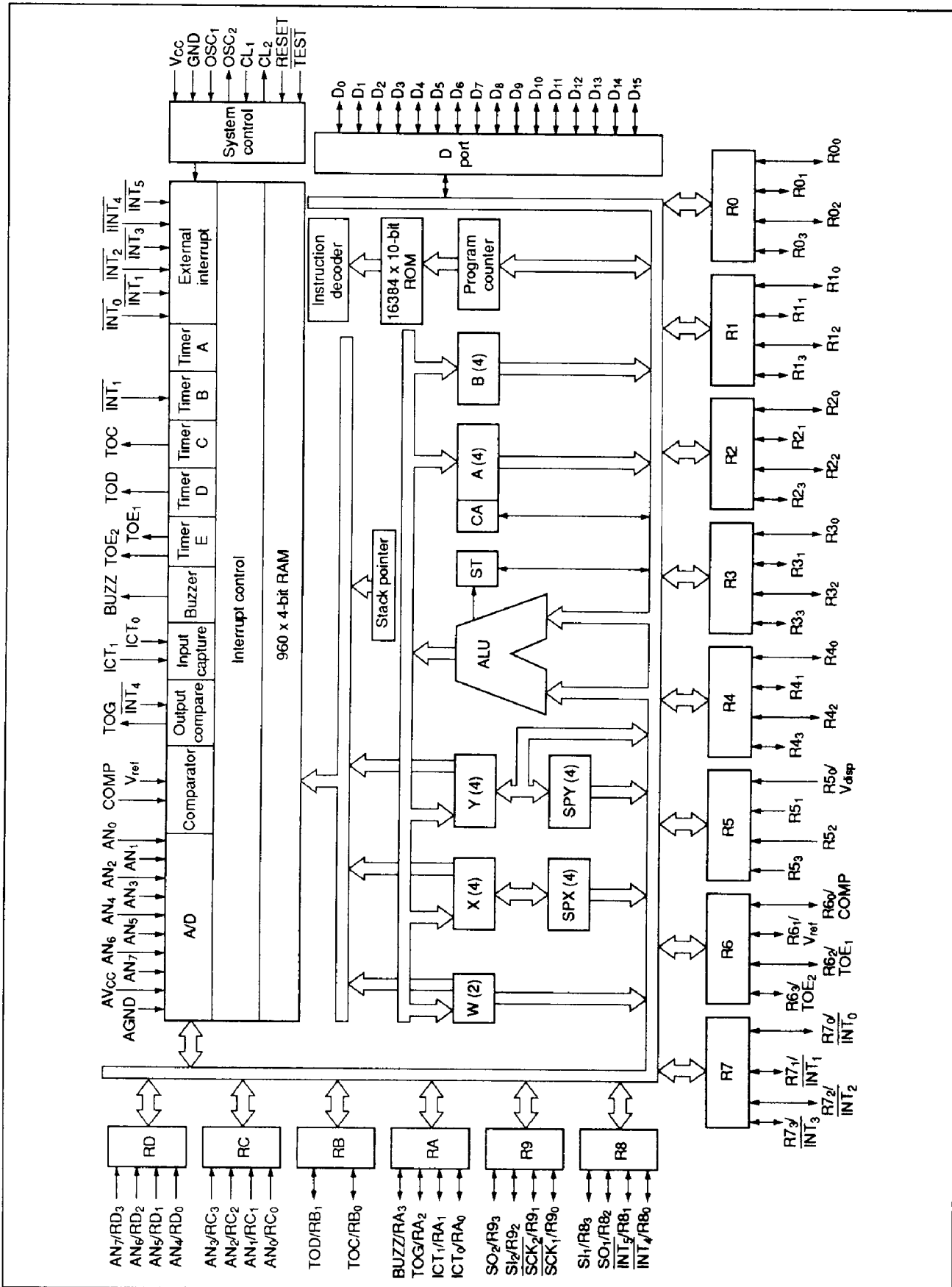

## Memory Map

### ROM Memory Map

The ROM memory map is shown in figure 1, and the ROM is described in detail below.

**Vector Address Area (\$0000–\$001F):** Reserved for JMPL instructions that branch to the start addresses of the reset and interrupt routines. After an MCU reset or interrupt execution, the program starts from the vector address.

**Zero-Page Subroutine Area (\$0000–\$003F):** Reserved for subroutines. The program branches to the subroutine in this area in response to the CAL instruction.

**Pattern Area (\$0000–\$0FFF):** Reserved for ROM data that is referenced as a pattern by the P instruction.

**Program Area (\$0000–\$3FFF):** Used for program code.

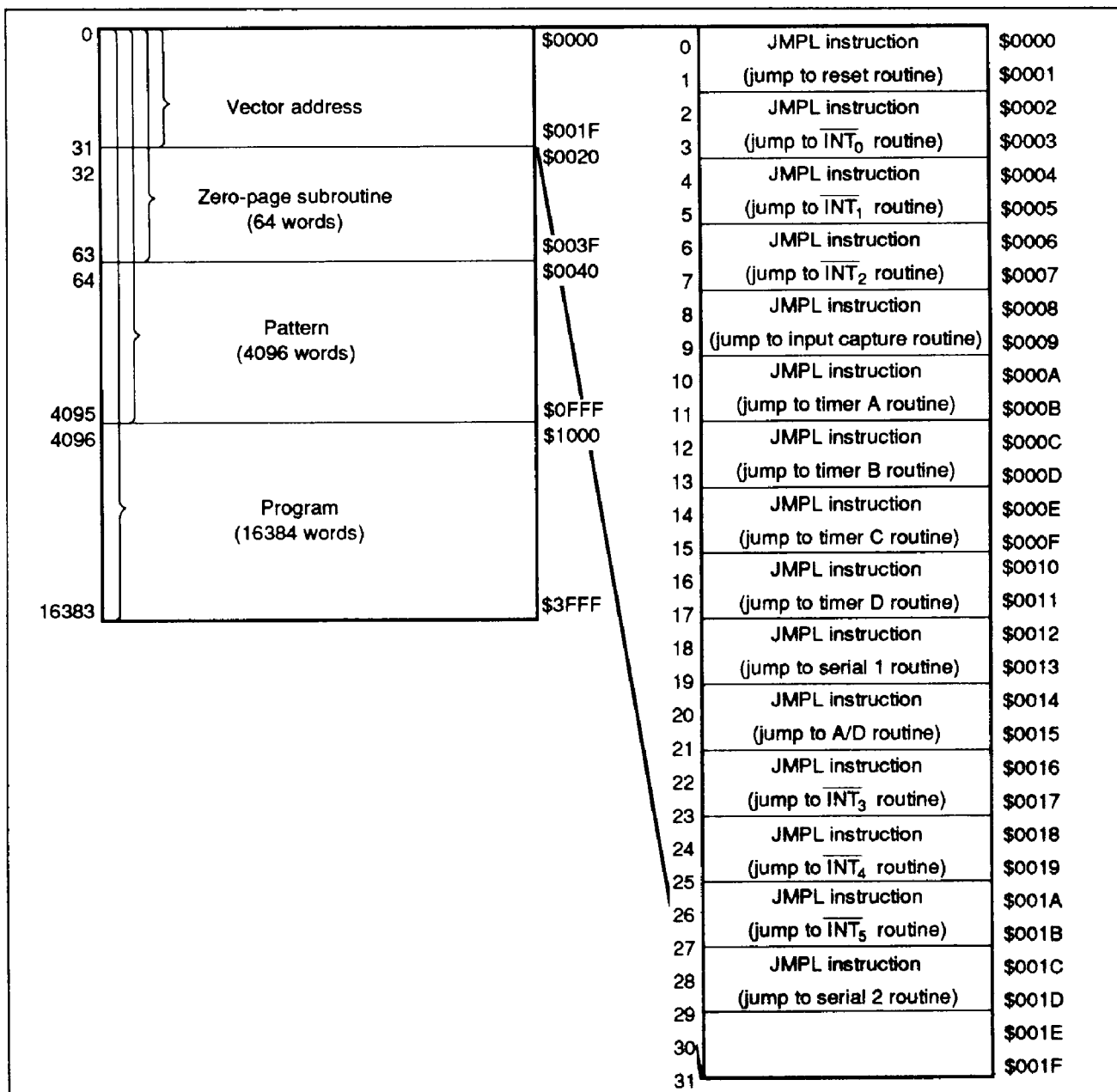

Figure 1 ROM Memory Map

## RAM Memory Map

The MCU contains a 960-digit  $\times$  4-bit RAM area for data and stack areas. In addition, interrupt control bits and special function registers are mapped onto the same RAM memory space outside this area. The RAM memory map is shown in figure 2 and the RAM area is described in detail below.

### Interrupt Control Bits Area (\$000–\$003, \$020–\$024)

: Used for interrupt control (figure 3). It can be accessed only by RAM bit manipulation instructions. However, note that the interrupt request flag cannot be set by software, the RSP bit is used only to reset the stack pointer, the DTON, LSON, and WDON flags are accessed only by RAM bit manipulation instructions, and the WDON flag can only be set to 1 by the SEM and SEMD instructions.

**Special Function Registers Area (\$004–\$01F, \$025–\$03F):** Used as mode registers for external interrupts, the serial interface, the timer/counters, and as data control registers and data registers for

I/O ports. As shown in figure 2, there are three types of registers: read-only, write-only, and read/write. These registers cannot be accessed by RAM bit manipulation instructions.

**Data Area (\$040–\$04F, \$050–\$3BF):** The memory registers (MR), which consist of 16 digits (\$040–\$04F), can also be accessed by the LAMR and XMRA instructions (figure 4).

**Stack Area (\$3C0–\$3FF):** Used for saving the contents of the program counter (PC), status flag (ST), and carry flag (CA) at subroutine call (CAL or CALL instruction) and interrupt processing. This area can be used as a 16-level nesting subroutine stack in which one level requires four digits. The stack area and data to be saved in it are shown in figure 4.

The program counter is popped from the stack by the RTN and RTNI instructions. The status and carry flags can only be popped from the stack by the RTNI instruction. Any unused area is available for data storage.



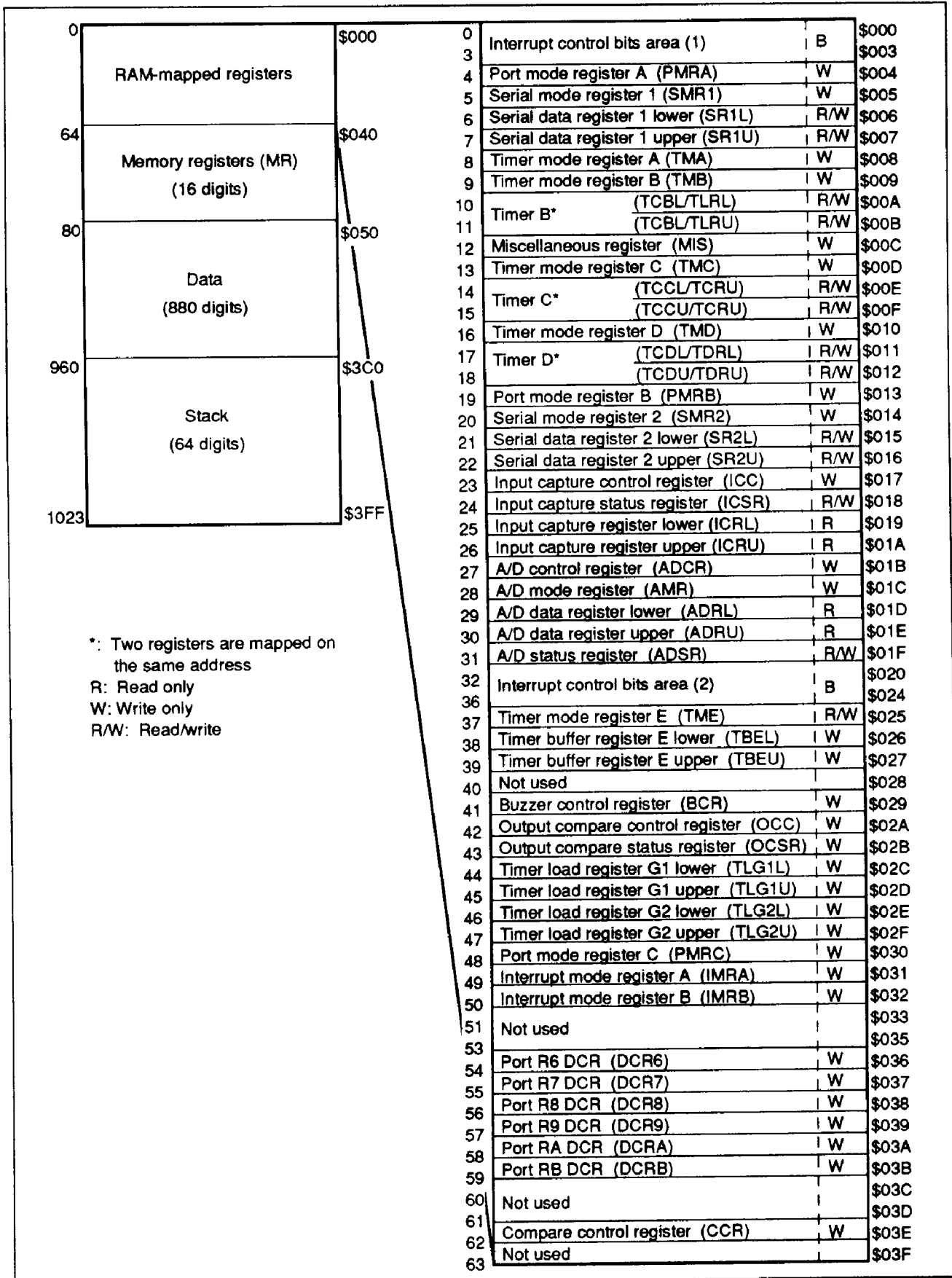

Figure 2 RAM Memory Map

	Bit 3	Bit 2	Bit 1	Bit 0	
0	IM0 (IM of INT <sub>0</sub> )	IF0 (IF of INT <sub>0</sub> )	RSP (Reset SP bit)	IE (Interrupt enable flag)	\$000
1	IM2 (IM of INT <sub>2</sub> )	IF2 (IF of INT <sub>2</sub> )	IM1 (IM of INT <sub>1</sub> )	IF1 (IF of INT <sub>1</sub> )	\$001
2	IMTA (IM of timer A)	IFTA (IF of timer A)	IMIC (IM of input capture)	IFIC (IF of input capture)	\$002
3	IMTC (IM of timer C)	IFTC (IF of timer C)	IMTB (IM of timer B)	IFTB (IF of timer B)	\$003
32	DTON (Direct transfer on flag)		WDON (Watchdog on flag)	LSON (Low speed on flag)	\$020
33	IMS1 (IM of serial 1)	IFS1 (IF of serial 1)	IMTD (IM of timer D)	IFTD (IF of timer D)	\$021
34	IM3 (IM of INT <sub>3</sub> )	IF3 (IF of INT <sub>3</sub> )	IMAD (IM of A/D)	IFAD (IF of A/D)	\$022
35	IM5 (IM of INT <sub>5</sub> )	IF5 (IF of INT <sub>5</sub> )	IM4 (IM of INT <sub>4</sub> )	IF4 (IF of INT <sub>4</sub> )	\$023
36			IMS2 (IM of serial 2)	IFS2 (IF of serial 2)	\$024

IF: Interrupt request flag  
 IM: Interrupt mask  
 IE: Interrupt enable flag  
 SP: Stack pointer

Note: Bits in the interrupt control bits area and register flag area are set by the SEM or SEMD instruction, reset by the REM or REMD instruction, and tested by the TM or TMD instruction. Other instructions have no effect.  
 However, note that the IF cannot be set by the SEM or SEMD instruction. If the RSP bit or a non-existent bit is tested by the TM or TMD instruction, its status is undefined.  
 The WDON flag can only be used by the SEM or SEMD instruction (it is reset only by MCU reset).

Figure 3 Configuration of Interrupt Control Bits and Register Flag Areas

Memory registers			Stack area		
64	MR (0)	\$040	960	Level 16	\$3C0
65	MR (1)	\$041		Level 15	
66	MR (2)	\$042		Level 14	
67	MR (3)	\$043		Level 13	
68	MR (4)	\$044		Level 12	
69	MR (5)	\$045		Level 11	
70	MR (6)	\$046		Level 10	
71	MR (7)	\$047		Level 9	
72	MR (8)	\$048		Level 8	
73	MR (9)	\$049		Level 7	
74	MR (10)	\$04A		Level 6	
75	MR (11)	\$04B		Level 5	
76	MR (12)	\$04C		Level 4	
77	MR (13)	\$04D		Level 3	
78	MR (14)	\$04E		Level 2	
79	MR (15)	\$04F	1023	Level 1	\$3FF

	Bit 3	Bit 2	Bit 1	Bit 0	
1020	ST	PC <sub>13</sub>	PC <sub>12</sub>	PC <sub>11</sub>	\$3FC
1021	PC <sub>10</sub>	PC <sub>9</sub>	PC <sub>8</sub>	PC <sub>7</sub>	\$3FD
1022	CA	PC <sub>6</sub>	PC <sub>5</sub>	PC <sub>4</sub>	\$3FE
1023	PC <sub>3</sub>	PC <sub>2</sub>	PC <sub>1</sub>	PC <sub>0</sub>	\$3FF

PC<sub>13</sub>–PC<sub>0</sub>: Program counter  
 ST: Status flag  
 CA: Carry flag

Figure 4 Configuration of Memory Registers and Stack Area, and Stack Position

## Functional Description

### Registers and Flags

The MCU has nine registers and two flags for CPU operations. They are shown in figure 5 and described below.

**Accumulator (A), B Register (B):** Four-bit registers used to hold results from the arithmetic logic unit (ALU) and to transfer data between memory, I/O, and other registers.

**W Register (W), X Register (X), Y Register (Y):** Two-bit (W) and four-bit (X and Y) registers used

for indirect RAM addressing. The Y register is also used for D-port addressing.

**SPX Register (SPX), SPY Register (SPY):** Four-bit registers used to supplement the X and Y registers.

**Carry Flag (CA):** One-bit flag that stores any ALU overflow generated by an arithmetic operation. CA is also affected by the SEC, REC, ROTL, and ROTR instructions. A carry is pushed onto the stack during an interrupt, and popped from the stack by the RTNI instruction—but not by the RTN instruction.

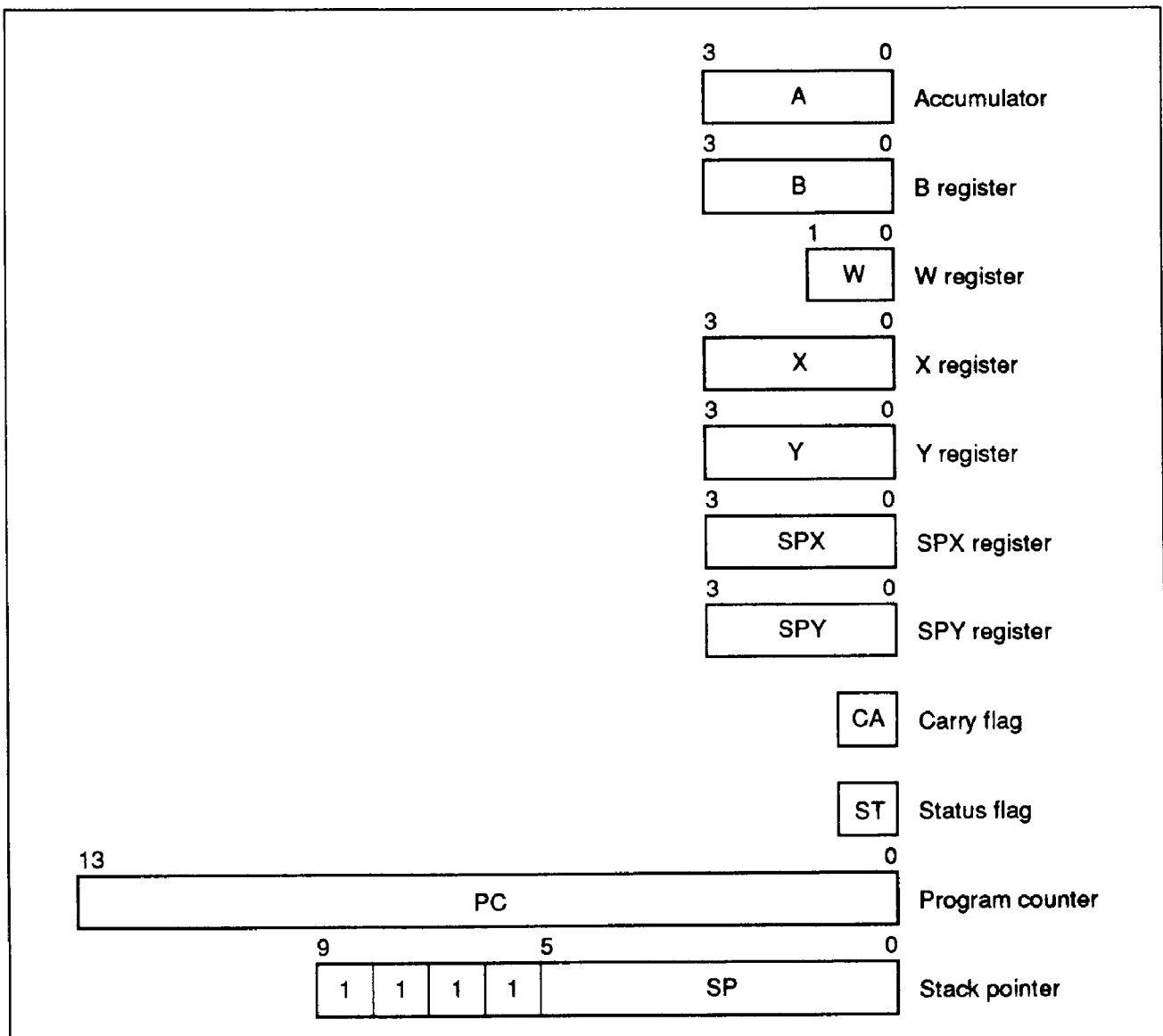

Figure 5 Registers and Flags

**Status Flag (ST):** One-bit flag that indicates an ALU overflow or ALU non-zero generated during an arithmetic or compare instruction, or the result of a bit test instruction. ST is used as a branch condition of the BR, BRL, CAL, and CALL instructions. The contents of ST remain unchanged until the next arithmetic, compare, or bit test instruction is executed, but become 1 after the BR, BRL, CAL, or CALL instruction is fetched, regardless of whether the instruction is executed or skipped. The contents of ST are pushed onto the stack during an interrupt, and popped from the stack by the RTNI instruction—but not by the RTN instruction.

**Program Counter (PC):** A 14-bit counter that points to the ROM address of the instruction being executed.

**Stack Pointer (SP):** Ten-bit pointer that contains the address of the stack area to be used next. The SP is initialized to \$3FF by MCU reset. It is decre-

mented by 4 when data is pushed onto the stack, and is incremented by 4 when data is popped from the stack. Since the top 4 bits of the SP are fixed to 1111, a stack of up to 16 levels can be used.

The SP is initialized to \$3FF in two ways: by MCU reset or by resetting the RSP bit with the REM or REMD instruction.

**Reset**

The MCU is reset by setting the RESET pin high. At power-on or when stop mode is cancelled, RESET must be high for at least one  $t_{RC}$  to enable the oscillator to stabilize. In other cases, a RESET input for two instruction cycles resets the MCU.

Initial values of the registers and counters after MCU reset are listed in table 1.

**Table 1 Initial Values after MCU Reset**

Item	Abbr.	Initial Value	Contents	
Program counter	(PC)	\$0000	Indicates program execution point from start address of ROM area	
Status flag	(ST)	1	Enables conditional branching	
Stack pointer	(SP)	\$3FF	Stack level 0	
Interrupt flags/mask	Interrupt enable flag	(IE)	0	Inhibits all interrupts
	Interrupt request flag	(IF)	0	Indicates there is no interrupt request
	Interrupt mask	(IM)	1	Prevents (masks) interrupt requests
I/O	Open-drain PMOS port data register	(PDR)	All bits 0	Enables output at level 0
	Standard port data register	(PDR)	All bits 1	Enables output at level 1
	Data control register	(DCR)	All bits 0	Turns output buffer off (to high impedance)
	Port mode register A	(PMRA)	0000	Refer to description of port mode register A
	Port mode register B	(PMRB)	0000	Refer to description of port mode register B
	Port mode register C	(PMRC)	0000	Refer to description of port mode register C
	Interrupt mode registers A, B	(IMRA, IMRB)	0000	Refer to description of interrupt mode registers A and B

**Table 1 Initial Values after MCU Reset (cont)**

Item	Abbr.	Initial Value	Contents	
Timer/ counters, serial interface	Timer mode register A	(TMA)	0000	Refer to description of timer mode register A
	Timer mode register B	(TMB)	0000	Refer to description of timer mode register B
	Timer mode register C	(TMC)	0000	Refer to description of timer mode register C
	Timer mode register D	(TMD)	0000	Refer to description of timer mode register D
	Timer mode register E	(TME)	0000	Refer to description of timer mode register E
	Serial mode register 1	(SMR1)	0000	Refer to description of serial mode register 1
	Serial mode register 2	(SMR2)	0000	Refer to description of serial mode register 2
	Prescaler S		\$000	—
	Prescaler W		\$00	—
	Timer counter A	(TCA)	\$00	—
	Timer counter B	(TCB)	\$00	—
	Timer counter C	(TCC)	\$00	—
	Timer counter D	(TCD)	\$00	—
	Timer buffer register E	(TBE)	\$00	Refer to description of timer buffer register E
	Timer load register B	(TLR)	\$00	Refer to description of timer load register B
	Timer load register C	(TCR)	\$00	Refer to description of timer load register C
	Timer load register D	(TDR)	\$00	Refer to description of timer load register D
	Octal counter (× 2)		000	—
	Timer load register G	(TLG)	\$0000	Refer to description of timer load register G
	A/D control register	(ADCR)	0000	Refer to description of A/D control register
Input capture control register	(ICC)	0000	Refer to description of input capture control register	
Input capture data register	(ICSR)	0000	Refer to description of input capture data register	
Buzzer control register	(BCR)	0000	Refer to description of buzzer control register	

**Table 1 Initial Values after MCU Reset (cont)**

Item		Abbr.	Initial Value	Contents
Timer/ counters, serial interface (cont)	Output compare control register	(OCC)	0000	Refer to description of output compare control register
	Output compare status register	(OCSR)	0000	Refer to description of output compare status register
	A/D status register	(ADSR)	0000	Refer to description of A/D status register
	A/D data register	(ADR)	\$80	Refer to description of A/D data register
	16-bit counter (timer counter G)	(TCG)	\$0000	—
	8-bit counter (timer counter F)	(TCF)	\$00	—
	Compare control register	(CCR)	0000	Refer to description of output compare control register
Bit register	Low speed on flag	(LSON)	0	Refer to description of operating modes
	Watchdog timer on flag	(WDON)	0	Refer to description of timer C
	Direct transfer on flag	(DTON)	0	Refer to description of operating modes
Miscellaneous register		(MIS)	0000	Refer to description of miscellaneous register

Note: The status of other registers and flags after MCU reset are shown below.

Item	Abbr.	Status after Cancellation of Stop Mode by MCU Reset	In Other Cases at MCU Reset
Carry flag	(CA)	Pre-MCU-reset values are not retained: values must be initialized by software	Pre-MCU-reset values are not retained: values must be initialized by software
Accumulator	(A)		
B register	(B)		
W register	(W)		
X/SPX register	(X/SPX)		
Y/SPY register	(Y/SPY)		
Serial 1 data register	(S1R)		
Serial 2 data register	(S2R)		
RAM		Pre-MCU-reset (pre-STOP-instruction) values are retained	

**Interrupts**

The MCU has 14 interrupt sources: six external signals ( $INT_0$ – $INT_5$ ), four timer/counters (timer A, timer B, timer C, and timer D), two serial interfaces (serial 1 and serial 2), an A/D converter, and an input capture. An interrupt request flag (IF), interrupt mask (IM), and vector address are provided for each interrupt source, and an interrupt enable flag (IE) controls the entire interrupt process.

**Interrupt Control Bits and Interrupt Processing:** Locations \$000 through \$003 and \$020 through \$024 in RAM are reserved for the interrupt control bits which can only be accessed by RAM bit manipulation instructions. The interrupt request flags (IFs) can only be set by signals from interrupt sources. MCU reset initializes the interrupt enable flag (IE) and interrupt request flags (IFs) to 0 and the interrupt masks (IMs) to 1.

A block diagram of the interrupt control circuit is

shown in figure 6, interrupt priorities and vector addresses are listed in table 2, and the interrupt processing conditions for the 14 interrupt sources are listed in table 3. An interrupt request occurs when the IF is set to 1 and the IM is set to 0. If the IE is 1 at that point, interrupt processing begins. A priority programmable logic array generates the vector address assigned to that interrupt source.

The interrupt processing sequence is shown in figure 7, and an interrupt processing flowchart is shown in figure 8. After an interrupt is acknowledged, the previous instruction is completed in the first cycle. The IE is reset in the second cycle, the carry flag, status flag, and program counter values are pushed onto the stack during the second and third cycles, and the program jumps to the vector address to execute the instruction in the third cycle.

Program the JMPL instruction at each vector address, to branch the program to the start address of the interrupt routine, and reset the IF by a software instruction within the interrupt routine.

**Table 2 Vector Addresses and Interrupt Priorities**

Reset/Interrupt	Priority	Vector Address
RESET	—	\$0000
$INT_0$	1	\$0002
$INT_1$	2	\$0004
$INT_2$	3	\$0006
Input capture	4	\$0008
Timer A	5	\$000A
Timer B	6	\$000C
Timer C	7	\$000E
Timer D	8	\$0010
Serial 1	9	\$0012
A/D	10	\$0014
$INT_3$	11	\$0016
$INT_4$	12	\$0018
$INT_5$	13	\$001A
Serial 2	14	\$001C

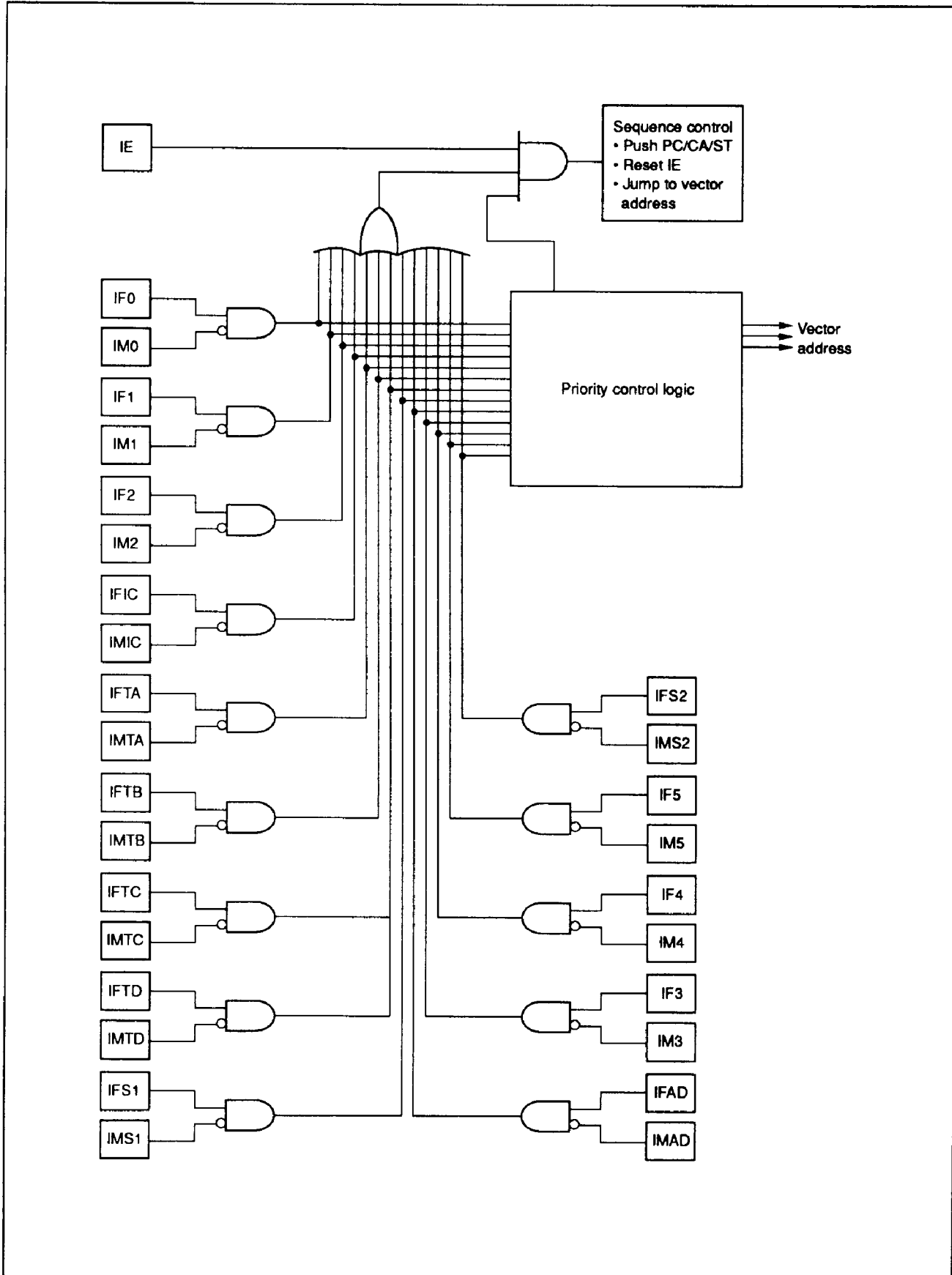

Figure 6 Block Diagram of Interrupt Control Circuit



**Table 3 Interrupt Conditions**

Interrupt Control Bit	Interrupt Source						
	INT <sub>0</sub>	INT <sub>1</sub>	INT <sub>2</sub>	Input Capture	Timer A	Timer B	Timer C
IE	1	1	1	1	1	1	1
IF0 • IM <sub>0</sub>	1	0	0	0	0	0	0
IF1 • IM <sub>1</sub>	*	1	0	0	0	0	0
IF2 • IM <sub>2</sub>	*	*	1	0	0	0	0
IFIC • IMIC	*	*	*	1	0	0	0
IFTA • IMTA	*	*	*	*	1	0	0
IFTB • IMTB	*	*	*	*	*	1	0
IFTC • IMTC	*	*	*	*	*	*	1
IFTD • IMTD	*	*	*	*	*	*	*
IFS1 • IMS1	*	*	*	*	*	*	*
IFAD • IMAD	*	*	*	*	*	*	*
IF3 • IM3	*	*	*	*	*	*	*
IF4 • IM4	*	*	*	*	*	*	*
IF5 • IM5	*	*	*	*	*	*	*
IFS2 • IMS2	*	*	*	*	*	*	*

\*: Bits marked by \* can be either 0 or 1. Their values have no effect on operation.

**Table 3 Interrupt Conditions (cont)**

Interrupt Control Bit	Interrupt Source						
	Timer D	Serial 1	A/D	TINT <sub>3</sub>	TINT <sub>4</sub>	TINT <sub>5</sub>	Serial 2
IE	1	1	1	1	1	1	1
IF0 • IM0	0	0	0	0	0	0	0
IF1 • IM1	0	0	0	0	0	0	0
IF2 • IM2	0	0	0	0	0	0	0
IFIC • IMIC	0	0	0	0	0	0	0
IFTA • IMTA	0	0	0	0	0	0	0
IFTB • IMTB	0	0	0	0	0	0	0
IFTC • IMTC	0	0	0	0	0	0	0
IFTD • IMTD	1	0	0	0	0	0	0
IFS1 • IMS1	*	1	0	0	0	0	0
IFAD • IMAD	*	*	1	0	0	0	0
IF3 • IM3	*	*	*	1	0	0	0
IF4 • IM4	*	*	*	*	1	0	0
IF5 • IM5	*	*	*	*	*	1	0
IFS2 • IMS2	*	*	*	*	*	*	1

\*: Bits marked by \* can be either 0 or 1. Their values have no effect on operation.

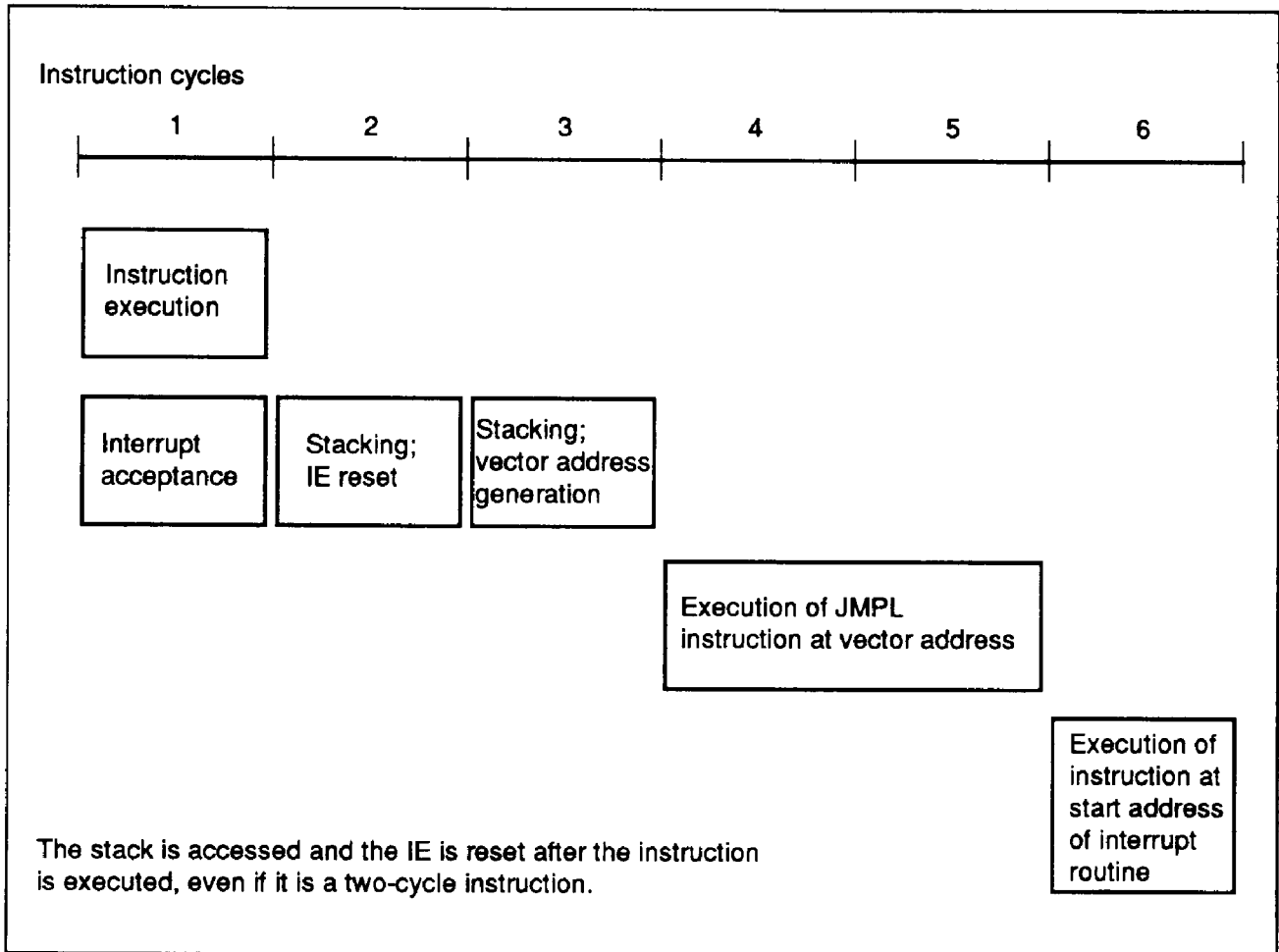

Figure 7 Interrupt Processing Sequence

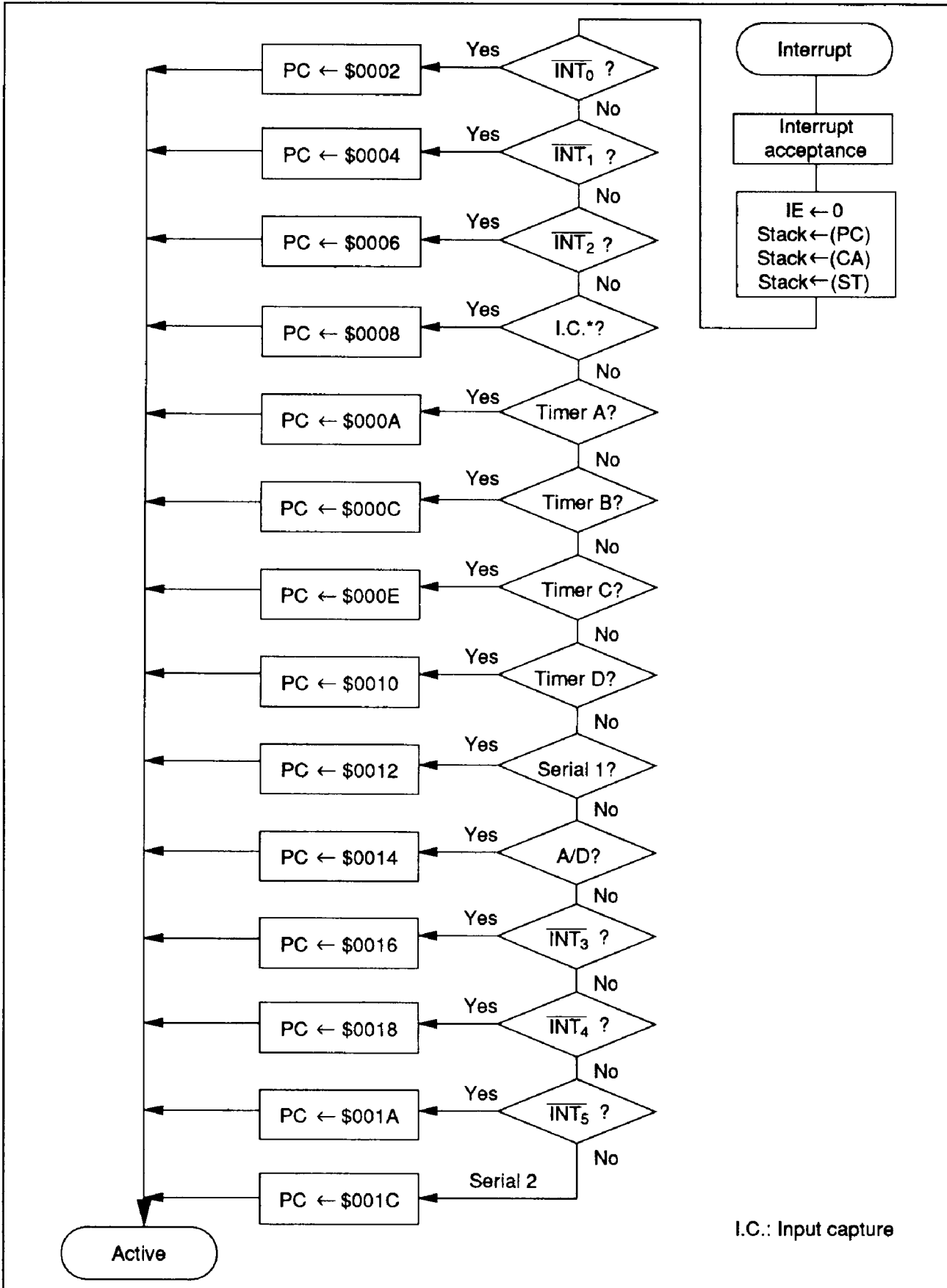

Figure 8 Interrupt Processing Flowchart

**Interrupt Enable Flag (IE: \$000, Bit 0):** Controls all interrupts (table 4). IE is reset to 0 by the interrupt processing and set to 1 by the RTNI instruction.

**External Interrupts ( $\overline{INT}_0$ – $\overline{INT}_5$ ):** The MCU has six external interrupt pins.

The  $\overline{INT}_1$  input can be used as a clock input for timer B in which case timer B increments at each edge selected by the interrupt mode register (IMRA). In this case, the external interrupt request flag (IM1) must be set to inhibit the  $\overline{INT}_1$  interrupt request. The  $\overline{INT}_4$  input can be used as an external trigger for the output compare timer.

**External Interrupt Request Flags (IF0: \$000, Bit 2; IF1: \$001, Bit 0; IF2: \$001, Bit 2; IF3: \$022, Bit 2; IF4: \$023, Bit 0; IF5: \$023, Bit 2):** Set at the rising or falling edges of the corresponding  $\overline{INT}_0$  to  $\overline{INT}_5$  inputs (table 5).

IF0, IF4, and IF5 are set at the falling edges of  $\overline{INT}_0$ ,  $\overline{INT}_4$ , and  $\overline{INT}_5$ , respectively, and IF1, IF2, and IF3 are set at either the rising or falling edges of  $\overline{INT}_1$ ,  $\overline{INT}_2$ , and  $\overline{INT}_3$ , respectively. The active edge is selected by the interrupt mode register (IMRA, IMRB).

**External Interrupt Masks (IM0: \$000, Bit 3; IM1: \$001, Bit 1; IM2: \$001, Bit 3; IM3: \$022, Bit 3; IM4: \$023, Bit 1; IM5: \$023, Bit 3):** Mask interrupt requests caused by the corresponding external interrupt request flags (table 6).

**Input Capture Interrupt Request Flag (IFIC: \$002, Bit 0):** Set by an overflow from the input capture timer and an input capture input (table 7).

**Input Capture Interrupt Mask (IMIC: \$002, Bit 1):** Masks an interrupt request caused by the input capture interrupt request flag (table 8).

**Table 4 Interrupt Enable Flag**

IE	Interrupt Enabled/Disabled
0	Disabled
1	Enabled

**Table 5 External Interrupt Request Flags**

IF0–IF5	Interrupt Request
0	Disabled
1	Enabled

**Table 6 External Interrupt Masks**

IM0–IM5	Interrupt Request
0	Enabled
1	Disabled (Masked)

**Table 7 Input Capture Interrupt Request Flag**

IFIC	Interrupt Request
0	Disabled
1	Enabled

**Table 8 Input Capture Interrupt Mask**

IMIC	Interrupt Request
0	Enabled
1	Disabled (Masked)

**Timer A Interrupt Request Flag (IFTA: \$002, Bit 2):** Set by an overflow from timer A (table 9).

**Timer C Interrupt Request Flag (IFTC: \$003, Bit 2):** Set by an overflow from timer C (table 13).

**Timer A Interrupt Mask (IMTA: \$002, Bit 3):** Masks an interrupt request caused by the timer A interrupt request flag (table 10).

**Timer C Interrupt Mask (IMTC: \$003, Bit 3):** Masks an interrupt request caused by the timer C interrupt request flag (table 14).

**Timer B Interrupt Request Flag (IFTB: \$003, Bit 0):** Set by an overflow from timer B (table 11).

**Timer D Interrupt Request Flag (IFTD: \$021, Bit 0):** Set by an overflow from timer D (table 15).

**Timer B Interrupt Mask (IMTB: \$003, Bit 1):** Masks an interrupt request caused by the timer B interrupt request flag (table 12).

**Timer D Interrupt Mask (IMTD: \$021, Bit 1):** Masks an interrupt request caused by the timer D interrupt request flag (table 16).

**Table 9 Timer A Interrupt Request Flag**

IFTA	Interrupt Request
0	Disabled
1	Enabled

**Table 13 Timer C Interrupt Request Flag**

IFTC	Interrupt Request
0	Disabled
1	Enabled

**Table 10 Timer A Interrupt Mask**

IMTA	Interrupt Request
0	Enabled
1	Disabled (Masked)

**Table 14 Timer C Interrupt Mask**

IMTC	Interrupt Request
0	Enabled
1	Disabled (Masked)

**Table 11 Timer B Interrupt Request Flag**

IFTB	Interrupt Request
0	Disabled
1	Enabled

**Table 15 Timer D Interrupt Request Flag**

IFTD	Interrupt Request
0	Disabled
1	Enabled

**Table 12 Timer B Interrupt Mask**

IMTB	Interrupt Request
0	Enabled
1	Disabled (Masked)

**Table 16 Timer D Interrupt Mask**

IMTD	Interrupt Request
0	Enabled
1	Disabled (Masked)

**Serial Interrupt Request Flags (IFS1: \$021, Bit 2; IFS2: \$024, Bit 0):** Set when the octal counter counts the eighth clock signal or when data transmission stops, resetting the octal counter (table 17).

**Serial Interrupt Masks (IMS1: \$021, Bit 3; IMS2: \$024, Bit 1):** Mask an interrupt request caused by the serial 1 and serial 2 interrupt request flags (table 18).

**A/D Interrupt Request Flag (IFAD: \$022, Bit 0):** Set by the completion of an A/D conversion (table 19).

**A/D Interrupt Mask (IMAD: \$022, Bit 1):** Masks an interrupt request caused by the A/D interrupt request flag (table 20).

---

**Table 17 Serial Interrupt Request Flags**

IFS1, IFS2	Interrupt Request
0	Disabled
1	Enabled

**Table 18 Serial Interrupt Masks**

IMS1, IMS2	Interrupt Request
0	Enabled
1	Disabled (Masked)

**Table 19 A/D Interrupt Request Flag**

IFAD	Interrupt Request
0	Disabled
1	Enabled

**Table 20 A/D Interrupt Mask**

IMAD	Interrupt Request
0	Enabled
1	Disabled (Masked)

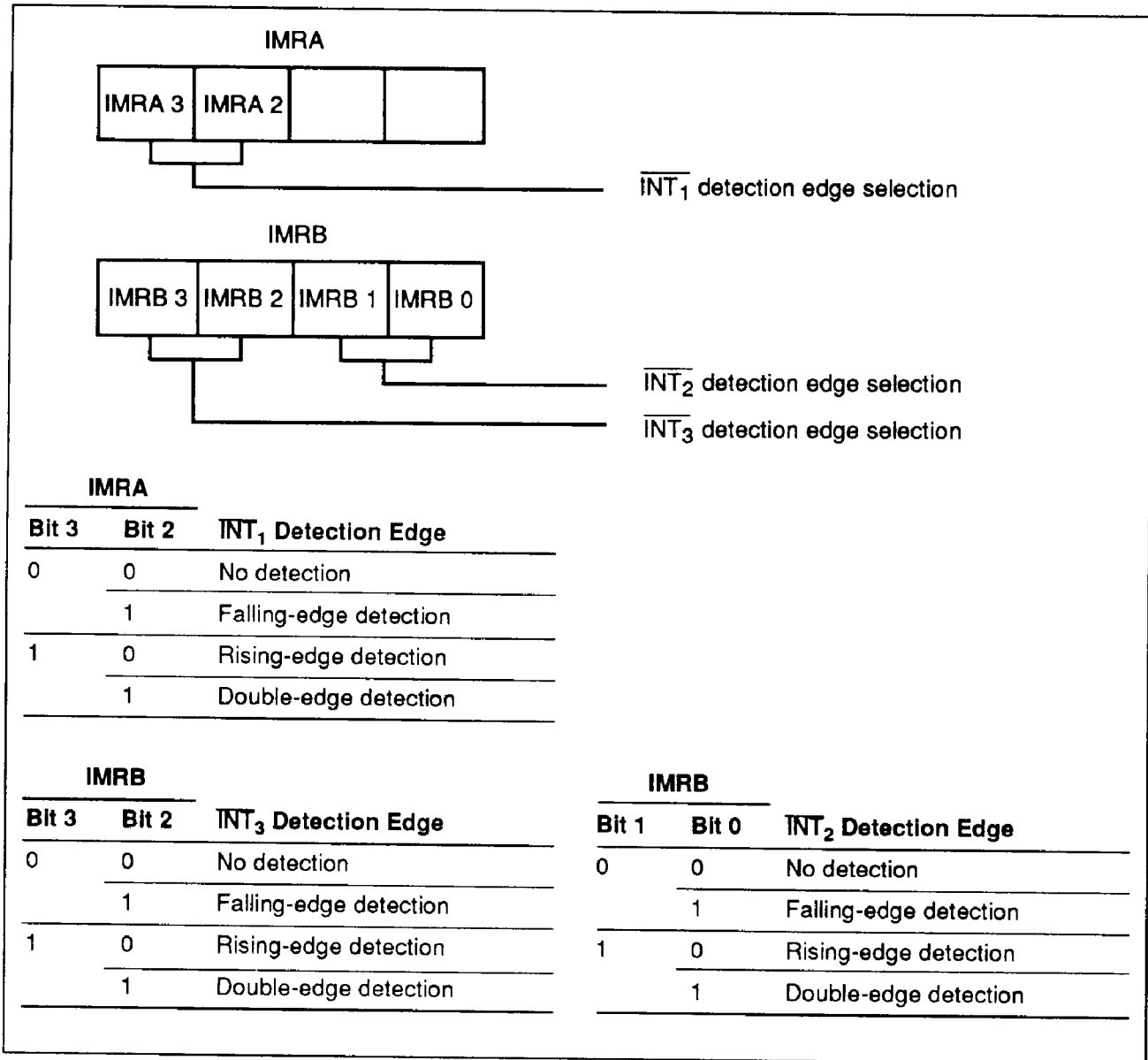

Figure 9 Interrupt Mode Register



### Operating Modes

Five operating modes are available, specified by how the clock is used, as shown in table 21. The functions available in each mode are listed in table 22, operations are listed in table 23, and transitions between operating modes are listed in figure 10.

**Active Mode:** The MCU operates according to the clock generated by the system oscillator.

**Standby Mode:** The MCU enters standby mode if the SBY instruction is executed in active mode.

In this mode, the oscillator remains active and peripheral functions such as interrupts, timer/counters, and the serial interface are enabled, although

all instruction-control clocks stop. The stopping of these clocks stops the CPU, retaining all RAM and register contents and maintaining the current I/O pin status.

Standby mode is terminated by a RESET input or an interrupt request. If it is terminated by a RESET input, the MCU is reset as well. After an interrupt request, the MCU enters active mode and executes the instruction following the SBY instruction. If the interrupt enable flag is 1, the interrupt is then processed; if it is 0, the interrupt request is left pending and the program is resumed. A flowchart of operation in standby mode is shown in figure 11.

Table 21 Low-Power Dissipation Modes

		System Clock ( $\phi_{CPU}$ )	
		Operating	Stopped
Non-time-base peripheral function clock ( $\phi_{PER}$ )	Operating	Active mode (LSON = 0)	Standby mode
	Stopped	Subactive mode (optional) (LSON = 1)	Watch mode (TMA3 = 1) Stop mode (TMA3 = 0)

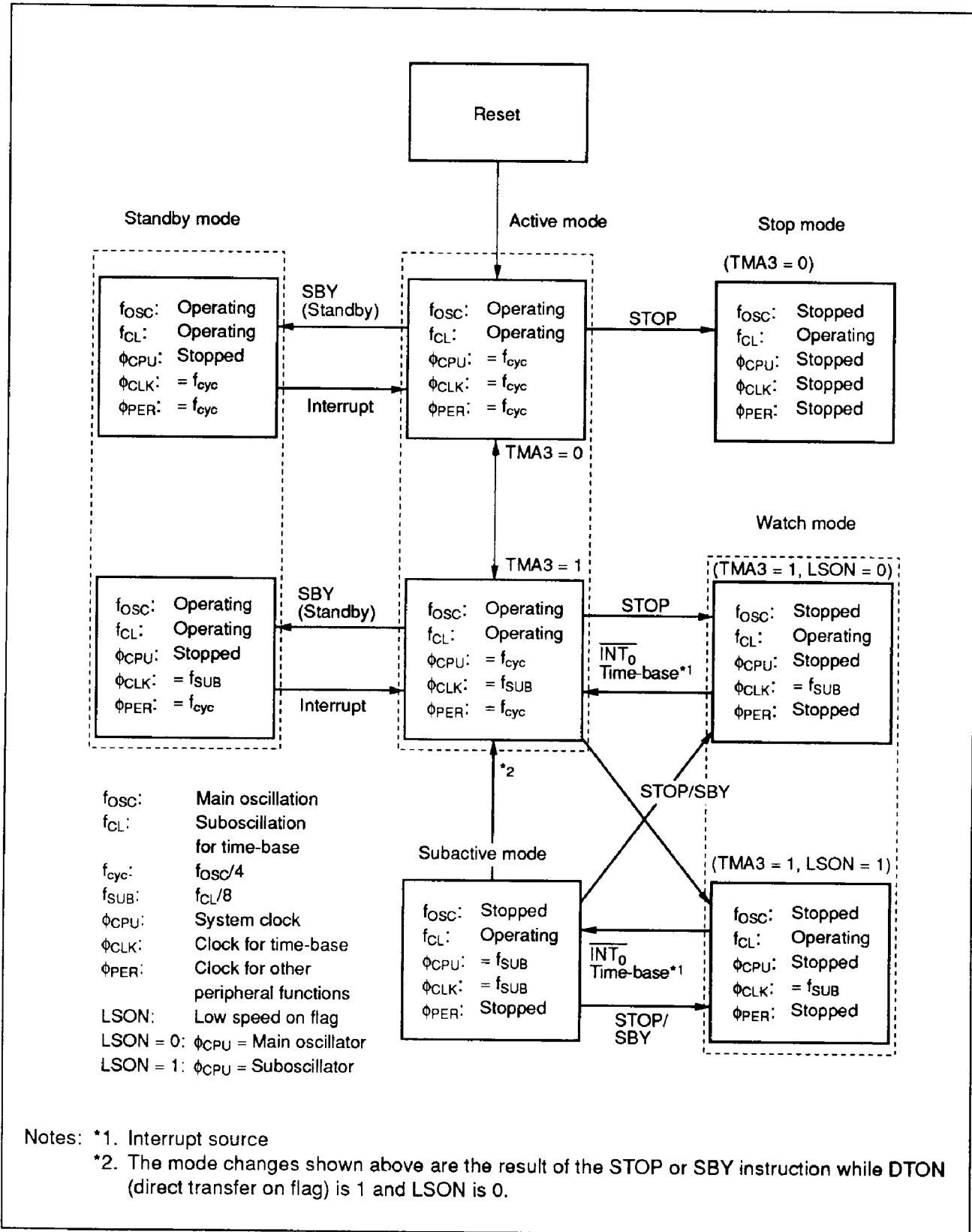

Figure 10 MCU Status Transitions

Table 22 Operations in Low-Power Dissipation Modes

Function		Stop Mode	Watch Mode	Standby Mode	Active Mode	Subactive Mode <sup>Note 4</sup>
System oscillator		Stopped	Stopped			Stopped
Subsystem oscillator		Note 2				
CPU operation ( $\phi_{CPU}$ )	Instruction execution	Stopped	Stopped	Stopped		
	RAM	Retained	Retained	Retained		
	Registers, flags	Reset	Retained	Retained		
	I/O <sup>Note 3</sup>	Reset	Retained	Retained		
Peripheral functions, interrupts ( $\phi_{PER}$ )	INT <sub>0</sub> –INT <sub>5</sub>	Reset	Retained			Retained
	Timer A	Reset	Retained			Retained
	Timer B	Reset	Retained			Retained
	Timer C	Reset	Retained			Retained
	Timer D	Reset	Retained			Retained
	Timer E (PWM)	Reset	Retained			Retained
	Input capture	Reset	Retained			Retained
	Output compare	Reset	Retained			Retained
	Serial 1, Serial 2	Reset	Retained			Retained
A/D	Reset	Retained			Retained	
Time-base functions, interrupts ( $\phi_{CLK}$ )	INT <sub>0</sub>	Reset	Note 5	Note 6	Note 6	Note 5
	Time-base	Reset	Note 5	Note 6	Note 6	Note 5

- Notes: 1.  indicates operating.  
 2. To reduce I<sub>CC</sub>, stop oscillation in external circuits.  
 3. Refer to table 23.  
 4. Subactive mode is an optional function.  
 5. Refer to the Interrupt Frame section.  
 6. If TMA3 is set to 1, timer A and INT<sub>0</sub> are switched to time-base function and interrupt, respectively.

Table 23 Input/Output in Low-Power Dissipation Modes

	Output		Input
	Standby Mode	Stop/Watch/ Subactive Mode	All Modes (Input state)
D <sub>0</sub> –D <sub>15</sub>	Retained/peripheral function output	High impedance	Input enabled
R <sub>0</sub> –R <sub>A</sub>	Retained/peripheral function output	High impedance	Input enabled

Note: Applying a voltage between (V<sub>CC</sub> – 0.3) and (GND + 0.3 V) to input-state pins increases the current between V<sub>CC</sub> and GND.

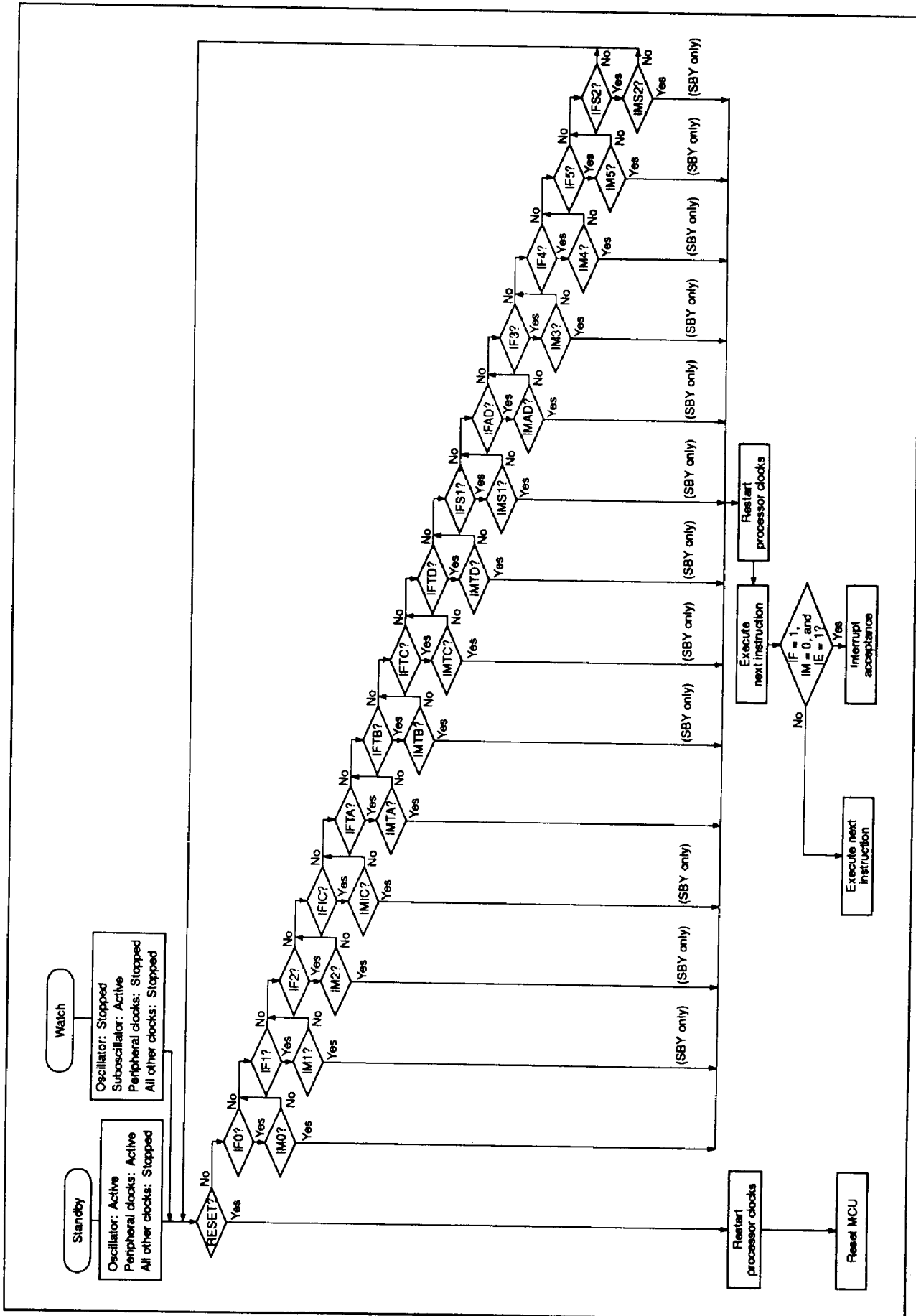

Figure 11 Flowchart of Watch and Standby Modes

**Stop Mode:** The MCU enters stop mode if the STOP instruction is executed in active mode while TMA3 = 0. In this mode, the system oscillator stops, causing all MCU functions to stop as well.

Stop mode is terminated by a RESET input as shown in figure 12. RESET must be high for at least one  $t_{RC}$  to stabilize oscillation (refer to the AC Characteristics section). In stop mode, all RAM contents are retained.

After stop mode is cancelled, the contents of the accumulator, B register, W register, X/SPX register, Y/SPY register, carry flag, and serial data register are not retained.

**Watch Mode:** The MCU enters watch mode if the STOP instruction is executed in active mode while TMA3 = 1, or if the STOP/SBY instruction is executed in subactive mode.

Watch mode is terminated by a RESET input, a timer A interrupt request, or a  $\overline{INT}_0$  interrupt request. For details of RESET input, refer to the Stop Mode section. When terminated by a timer A interrupt request or a  $\overline{INT}_0$  interrupt request, the

MCU enters active mode if LSON is 0 or subactive mode if LSON is 1. Any interrupt request generated during the transition to active mode is delayed for half the interrupt frame period ( $t_{RC}$ ) to give the oscillation time to stabilize (figure 14). Operation during mode transition is the same as that at stand-by mode cancellation (figure 11).

**Subactive Mode:** The CPU operates with a clock generated by the CL<sub>1</sub> and CL<sub>2</sub> oscillation circuits. Functions which can operate in subactive mode are listed in table 23.

The MCU enters active mode from subactive mode by the following steps. The MCU enters watch mode if the STOP or SBY instruction is executed in subactive mode while the LSON is reset and the DTON is set. At the next interrupt frame, the MCU waits for the oscillation time selected by the MIS to stabilize, and then enters active mode (figure 13). After that, the DTON is automatically reset (the DTON can be set only in subactive mode).

Subactive mode is an optional function that the user must specify on the function option list.

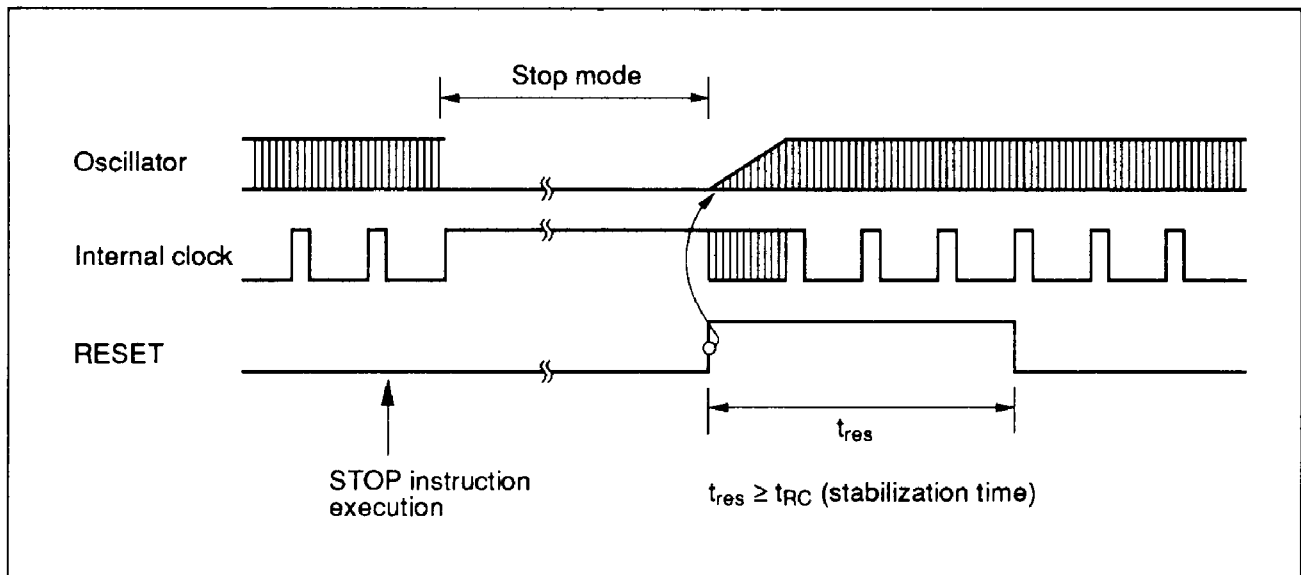

Figure 12 Timing of Stop Mode Cancellation

**Interrupt Frame:** In watch and subactive modes, timer A and  $\overline{INT}_0$  interrupts are generated in synchronism with the interrupt frame. The interrupt frame is repeated at the timing shown in figure 14. Three interrupt frame cycles can be selected by the settings of the miscellaneous register (figure 15).

Operation during the transition from watch mode to active mode is the same as a standby mode cancellation. The overflow timing during the transition to active mode by the timer A interrupt request is the same as the interrupt strobe shown in figure 14.

The period from the interrupt strobe to the interrupt request generation is used as the oscillation time to stabilize during the transition from watch mode to

**MCU Operation Sequence:** The MCU operates in the sequence shown in figures 16 to 18. It is reset by a RESET input, regardless of its state.

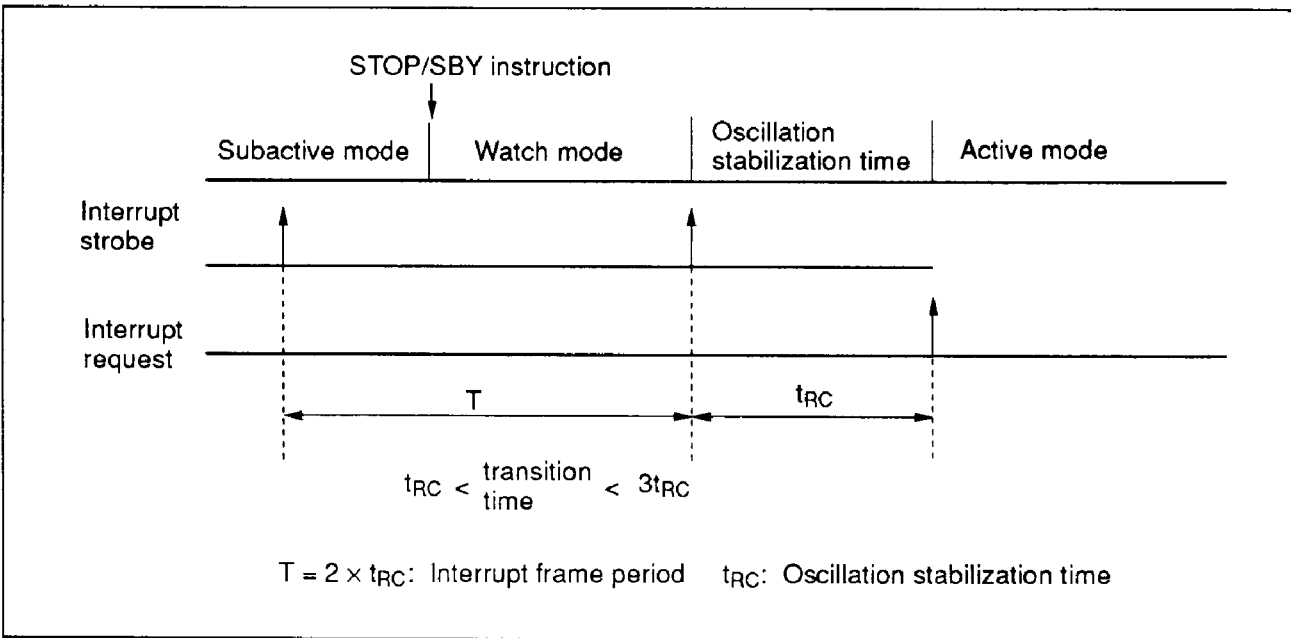

Figure 13 Timing of Subactive Mode Direct Transition

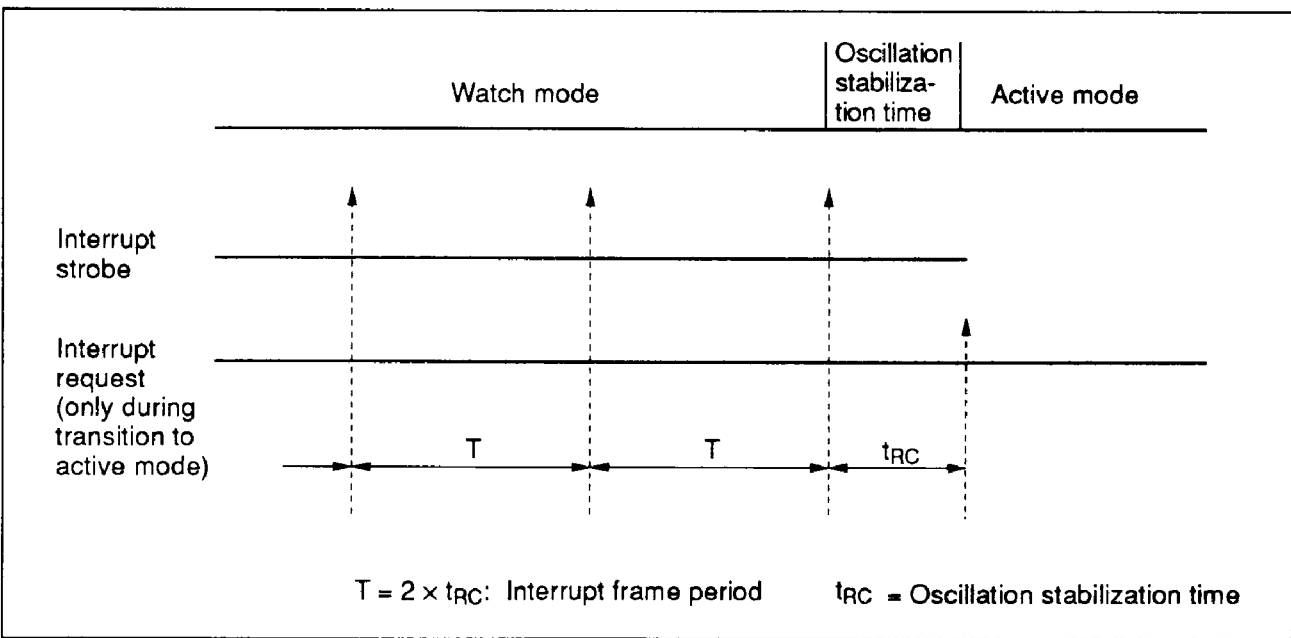

Figure 14 Interrupt Frame

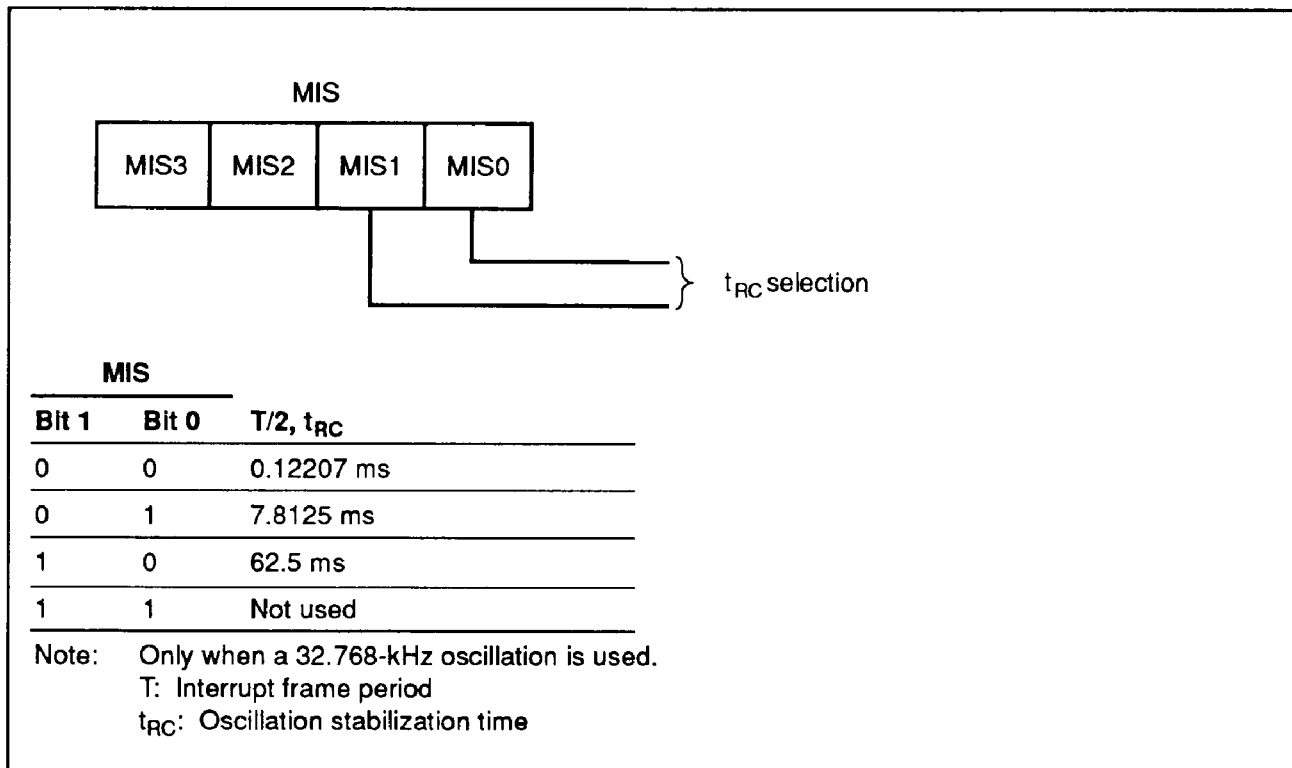

Figure 15 Miscellaneous Register

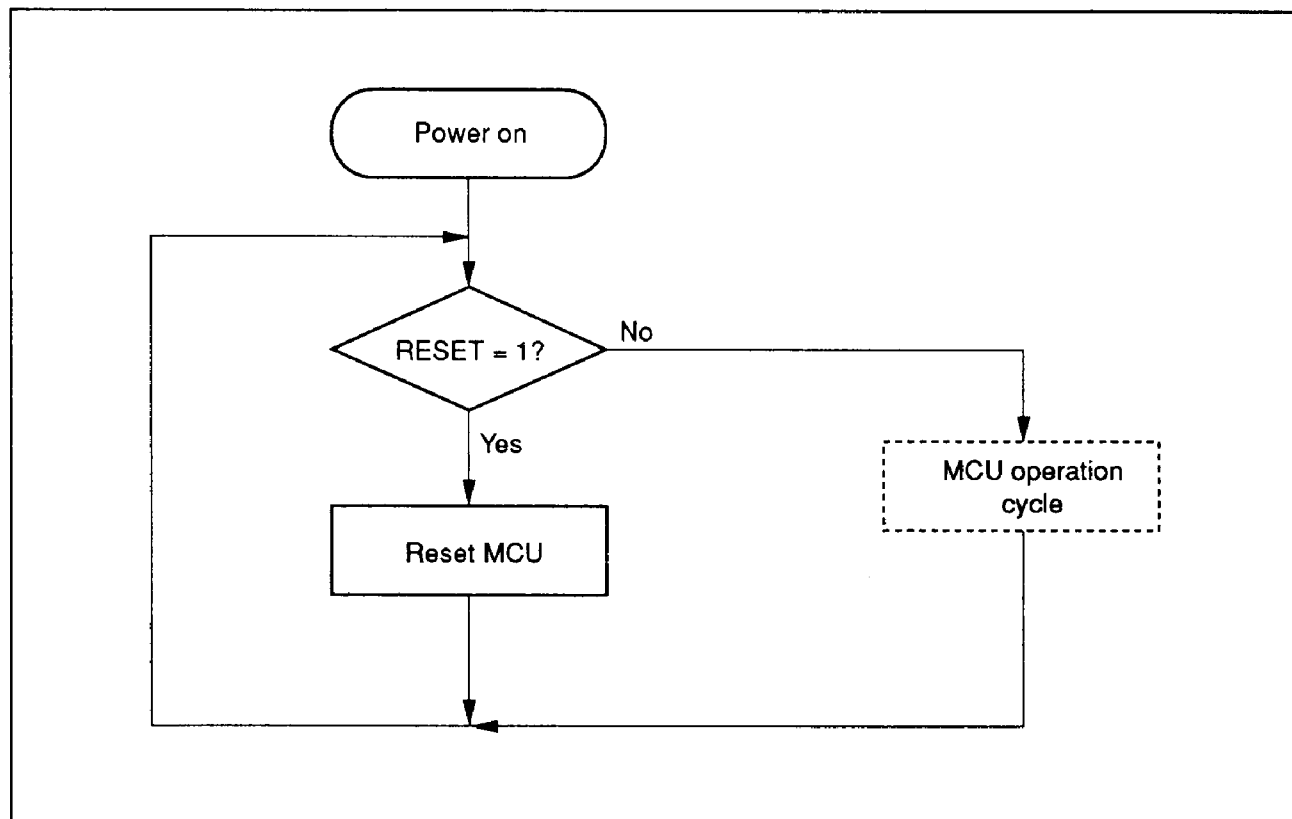

Figure 16 MCU Operation Flowchart (Power On)





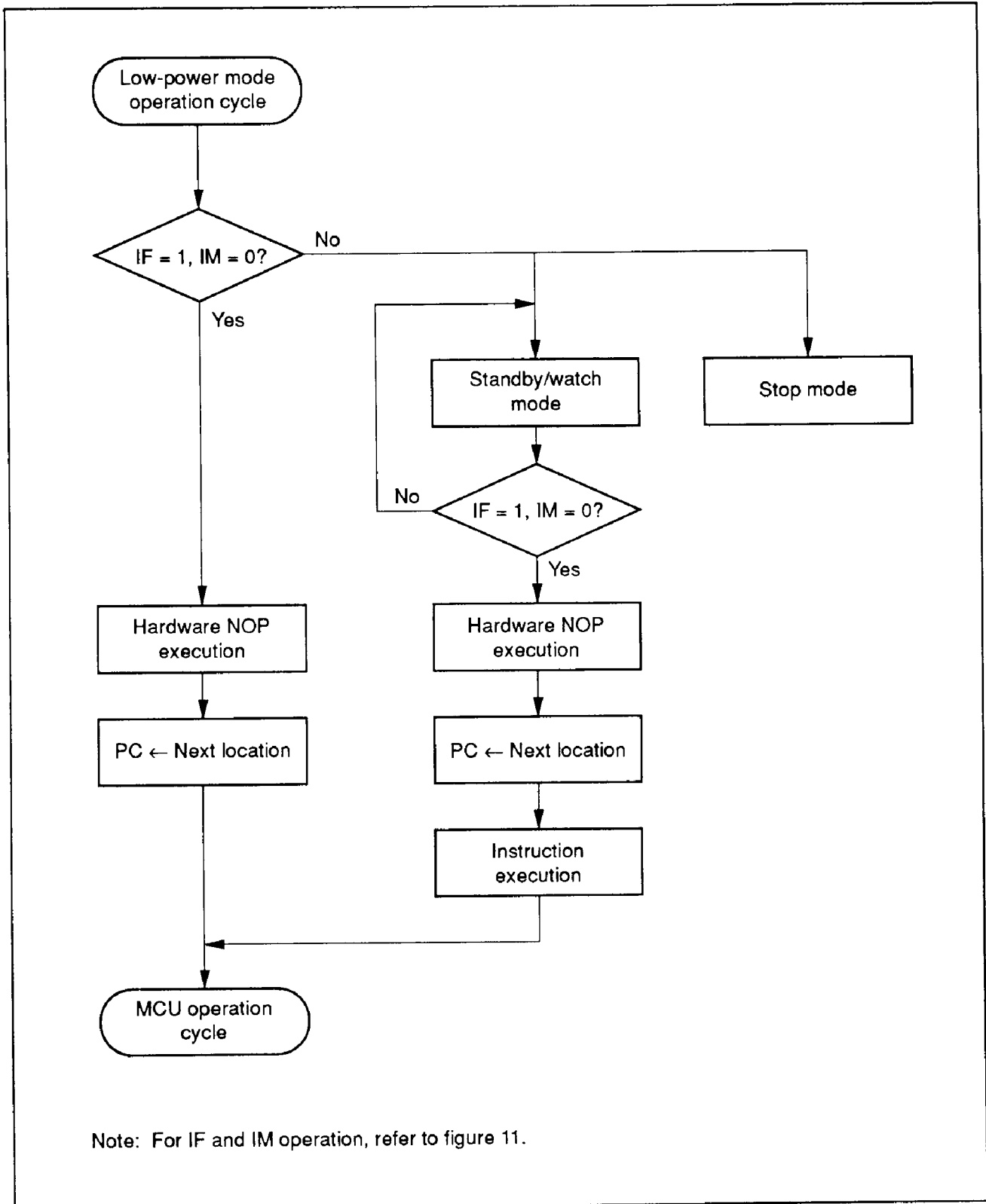

Figure 18 MCU Operation Flowchart (Low-Power Dissipation Mode Operation)

### Internal Oscillation Circuit

A block diagram of the internal oscillation circuit is shown in figure 19. As shown in table 24, a crystal or a ceramic oscillator can be connected to OSC<sub>1</sub> and OSC<sub>2</sub>, and a crystal oscillator of 32.768-kHz can be connected to CL<sub>1</sub> and CL<sub>2</sub>.

An external clock operation of the system oscillator is also available. If not using a subsystem oscillator, fix the CL<sub>1</sub> pin to V<sub>CC</sub> or GND.

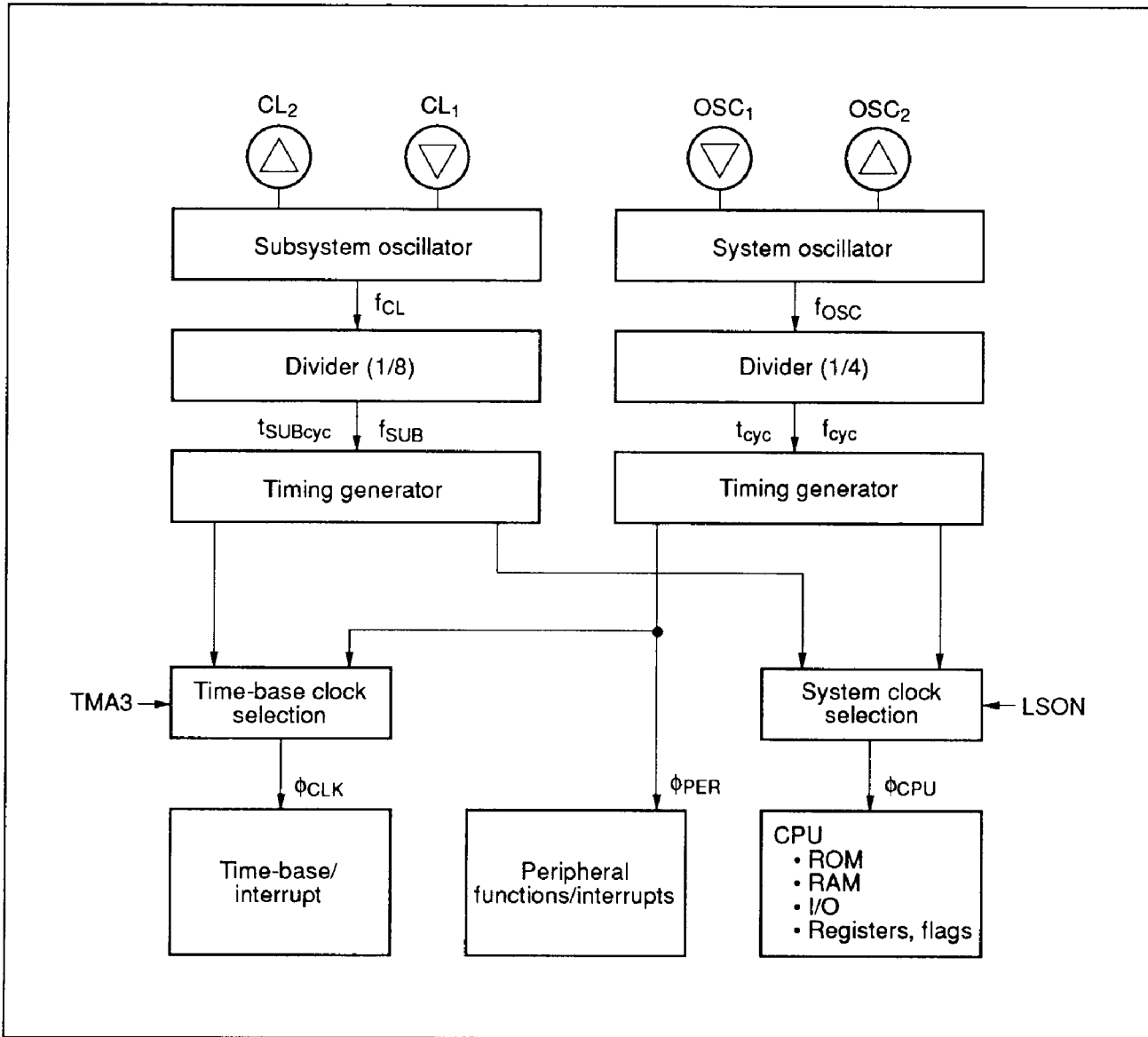

Figure 19 Internal Oscillator Circuit

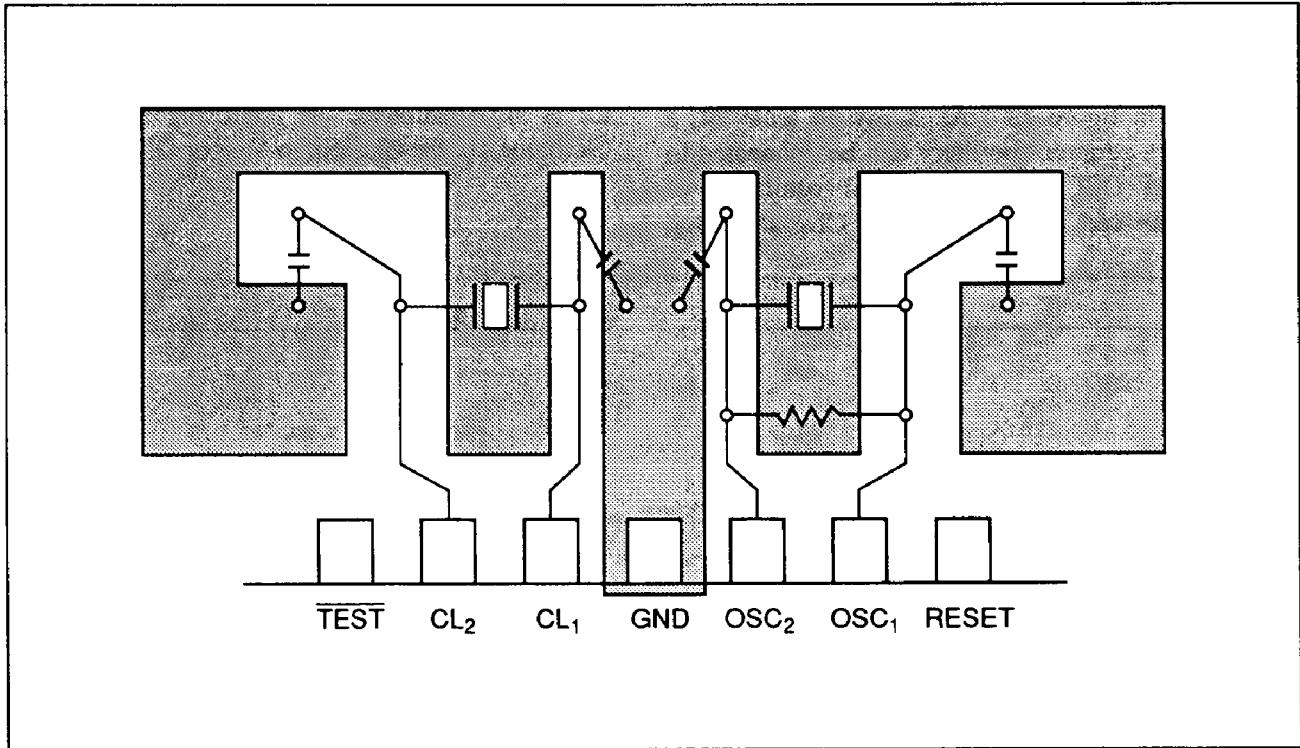
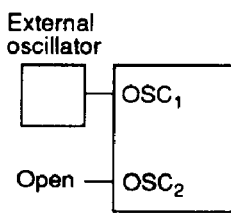
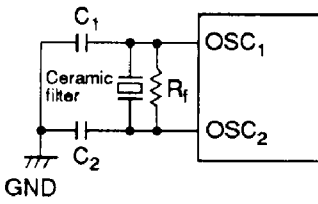
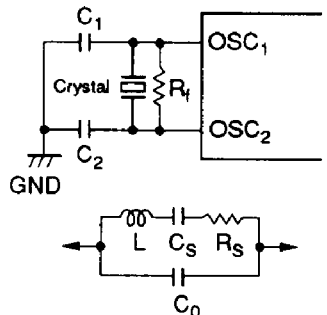
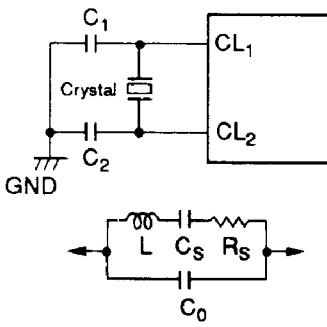

Figure 20 Pattern Layout Example of Oscillation Circuit

Table 24 Oscillator Circuit Examples

Circuit Configuration	Circuit Constants
External clock operation (OSC <sub>1</sub> , OSC <sub>2</sub> )	
Ceramic filter oscillator (OSC <sub>1</sub> , OSC <sub>2</sub> )	 <p data-bbox="981 638 1268 772">                         Ceramic filter:                          CSA4.00MG (Murata)  <math>R_f = 1\text{ M}\Omega \pm 20\%</math>  <math>C_1 = C_2 = 33\text{ pF} \pm 20\%</math> </p>
Crystal oscillator (OSC <sub>1</sub> , OSC <sub>2</sub> )	 <p data-bbox="981 963 1332 1198"> <math>R_f = 1\text{ M}\Omega \pm 20\%</math>  <math>C_1 = C_2 = 22\text{ pF} \pm 20\%</math>                          Crystal: Equivalent to circuit shown at bottom left  <math>C_0 = 7\text{ pF, max.}</math>  <math>R_s = 100\ \Omega, \text{ max.}</math>  <math>f = 1.6\text{ to }4.5\text{ MHz}</math> </p>
Crystal oscillator (CL <sub>1</sub> , CL <sub>2</sub> )	 <p data-bbox="981 1355 1252 1556"> <math>C_1 = C_2 = 15\text{ pF} \pm 5\%</math>                          Crystal: MX38T                          (Nihon Dempa Kogyo)  <math>C_0 = 1.5\text{ pF, typ.}</math>  <math>R_s = 14\text{ k}\Omega, \text{ typ.}</math>  <math>f = 32.768\text{-kHz}</math> </p>

- Notes:
1. The circuit constants given above are recommended values provided by the oscillator manufacturer. Since they may be affected by stray capacitances from the oscillator or board, consult the crystal oscillator or ceramic filter manufacturer to determine the actual circuit parameters required.
  2. Wiring between the OSC<sub>1</sub>/OSC<sub>2</sub> pins and other elements must be as short as possible, and must not cross other wiring. Refer to the recommended layout of the oscillation circuit in figure 20.
  3. If not using a 32.768-kHz crystal oscillator, fix the CL<sub>1</sub> pin to GND and leave the CL<sub>2</sub> pin open.

## Input/Output

The MCU (mask ROM version) has 70 input/output pins, 33 of the input/output pins being standard pins whose circuits can be selected as with pull-up MOS (B) or without pull-up MOS (C) option.

The HD404719 has 37 other high-voltage pins whose circuits can be selected as with pull-down MOS (E) or without pull-down MOS (D) option. If the former option is selected, the  $R5_0/V_{disp}$  pin must be set as  $V_{disp}$  by the mask option because the source of the pull-down MOS is connected to  $V_{disp}$ .

The HD404439 has no high-voltage pins. The pins corresponding to the HD404719 high-voltage pins are standard open-drain PMOS pins in the HD404439. The circuits must be without pull-down MOS (D). The  $R5_0$  pin is only used as an input port.

The HD4074719 has only the pins without pull-up MOS (C) and without pull-down MOS (D).

**D Port:** The 16 out of 70 I/O pins that are discrete pins (D port), accessed individually. These pins are set by the SED and SEDD instructions, reset by the RED and REDD instructions, and tested by the TD and TDD instructions.

**R Ports:** Accessed in 4-bit units. Data is input to the ports by the LAR and LBR instructions and output from them by the LRA and LRB instructions. The R6 to RB output buffers are turned on and off by R-port data control registers (DCR6–DCRB).

**Mask Options:** The circuits of the HD4074719 are either without pull-up MOS (C) or without pull-down MOS (D), as shown in table 25 and figure 21. Options either with pull-up MOS (B) or with pull-down MOS (E) can be selected for the HD404719, and an option with pull-up MOS (B) can be selected for the HD404439. However, note that these MCUs are not compatible with the HD4074719.

**How to Deal with Unused I/O Pins:** I/O pins that are not needed by the user system must be fixed as follows to prevent LSI malfunctions due to noise. Note the following precautions:

- For high-voltage pins, the without pull-down MOS option must be selected. The pins are connected to the  $V_{CC}$  voltage of the user system.
- For standard pins, the without pull-down MOS option must be selected. The pins are connected to the GND voltage of the user system.
- Open-drain PMOS pins are connected to the  $V_{CC}$  voltage of the user system.

Table 25 Input/Output Pin Types

Standard Pins

Pin Type	With Pull-Up MOS (B)/Without Pull-Up MOS (C)	Pin Name
I/O pins		<p>R6<sub>0</sub>-R6<sub>3</sub>                      R7<sub>0</sub>-R7<sub>3</sub>                      R8<sub>0</sub>-R8<sub>3</sub>                      R9<sub>0</sub>-R9<sub>3</sub>                      RA<sub>0</sub>-RA<sub>3</sub>                      RB<sub>0</sub>-RB<sub>1</sub></p>
Input pins		<p>R5<sub>1</sub>-R5<sub>3</sub>                      RC<sub>0</sub>-RC<sub>3</sub>                      RD<sub>0</sub>-RD<sub>3</sub></p>

Table 25 Input/Output Pin Types (cont)

Standard Pins

Pin Type	With Pull-Up MOS (B)/Without Pull-Up MOS (C)	Pin Name
Peripheral I/O pins		<p>SCK<sub>1</sub> SCK<sub>2</sub> (output)<sup>Note 1</sup></p>
Peripheral output pins		<p>SO<sub>1</sub>, SO<sub>2</sub> TOC TOD TOE<sub>1</sub>, TOE<sub>2</sub> TOG BUZZ</p>

Table 25 Input/Output Pin Types (cont)

Standard Pins

Pin Type	With Pull-Up MOS (B)/Without Pull-Up MOS (C)	Pin Name
Peripheral input pins		$SCR_1, SCR_2$ (input) <sup>Note 1</sup> $SI_1, SI_2$ $INT_0$ $INT_1$ $INT_2$ $INT_3$ $INT_4$ $ICT_0, ICT_1$
		
		$AN_0-AN_7$ $V_{ref} (R6_1)$
		



Table 25 Input/Output Pin Types (cont)

Standard Pins

Pin Type	With Pull-Up MOS (B)/Without Pull-Up MOS (C)	Pin Name
I/O pins		R6 <sub>0</sub> /COMP

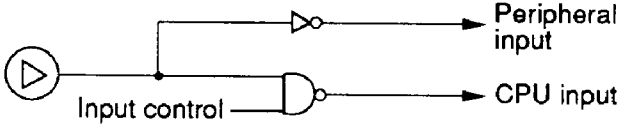
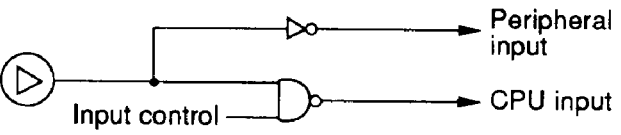
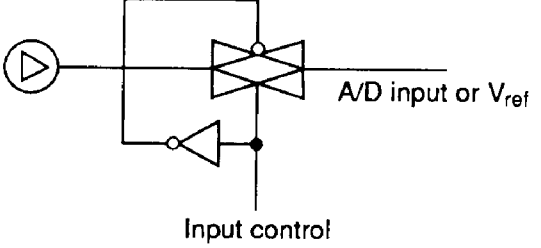
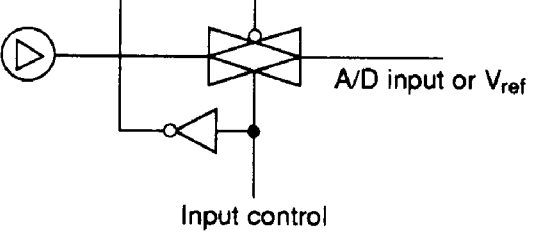
High-Voltage Pins (Open-Drain PMOS Pins)

Pin Type	Without Pull-Down MOS (D)/With Pull-Down MOS (E)	Pin Name
I/O pins		D <sub>0</sub> -D <sub>15</sub> R <sub>0</sub> -R <sub>3</sub> R <sub>10</sub> -R <sub>13</sub> R <sub>20</sub> -R <sub>23</sub> R <sub>30</sub> -R <sub>33</sub> R <sub>40</sub> -R <sub>43</sub>

Table 25 Input/Output Pin Types (cont)

High-Voltage Pins

Pin Type	Without Pull-Down MOS (D)	Pin Name
Input pins		R5 <sub>0</sub>

- Notes:
1. If external clock mode is selected when the serial interface is used,  $SCK_1$  and  $SCK_2$  are used as input pins.
  2. In stop mode, the MCU is internally reset and peripheral functions are cancelled. The HLT signal goes high and the output pins are at high impedance.
  3. In watch/subactive mode, the HLT signal goes high and the output pins are at high impedance. The input level of I/O pins selected for peripheral functions must be fixed since these pins are in input state.
  4. Select the circuit type for a mask ROM MCU as shown below. A mask ROM MCU is compatible with a ZTAT™ MCU only when C- and D-type circuits are selected for the mask ROM MCU.
  5. The HD404439 has no high-voltage pins. The pins corresponding to the high-voltage pins are standard open-drain PMOS pins, therefore, the circuits must be used as with pull-down MOS (D). Option E cannot be selected.

Product Type	Circuit Type			
	B	C	D	E
Mask ROM (HD404719)	Optional			
Mask ROM (HD404439)	Optional		Fixed	
ZTAT™ (HD4074719)		Fixed		

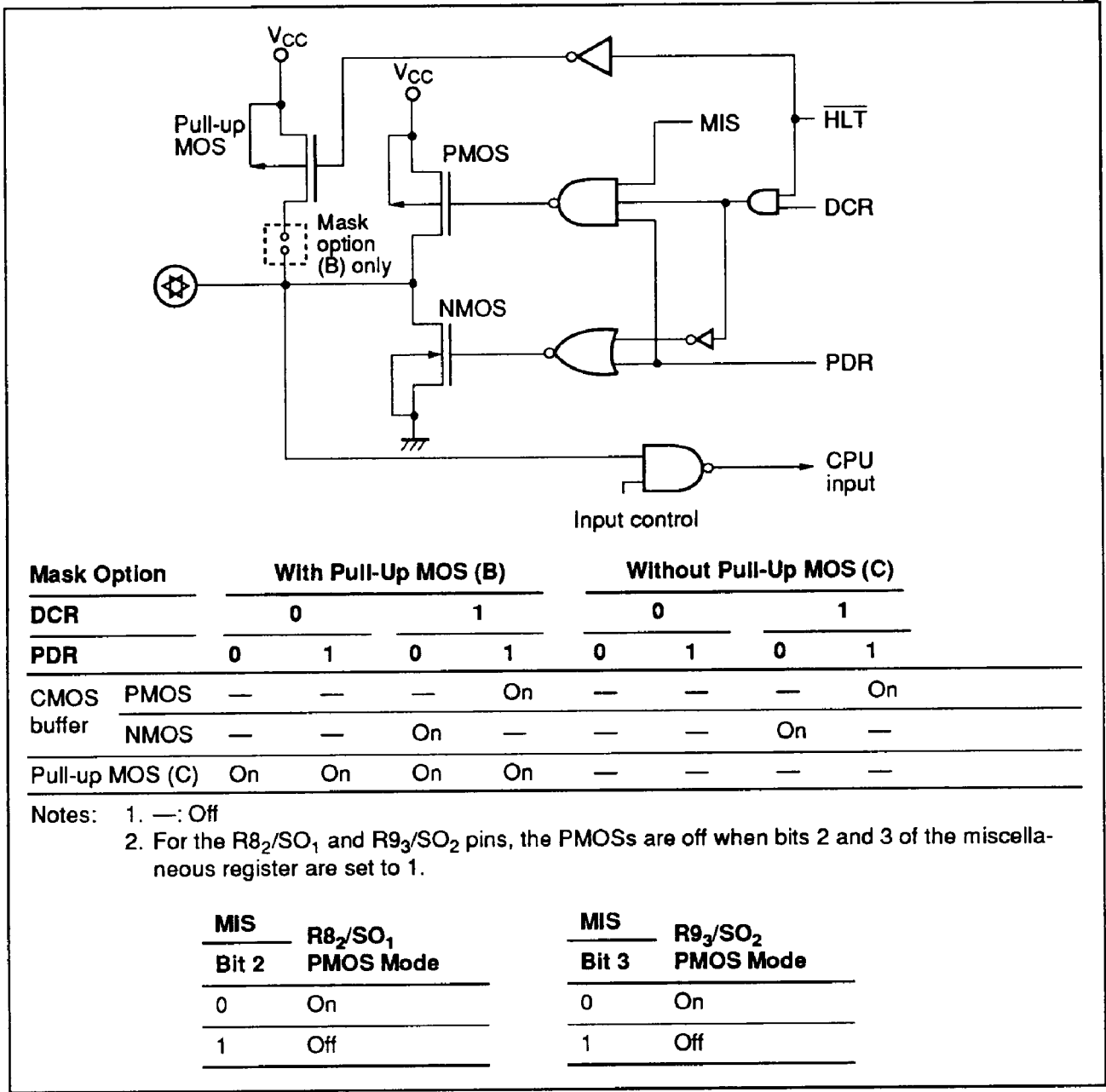

Figure 21 Input/Output Buffer

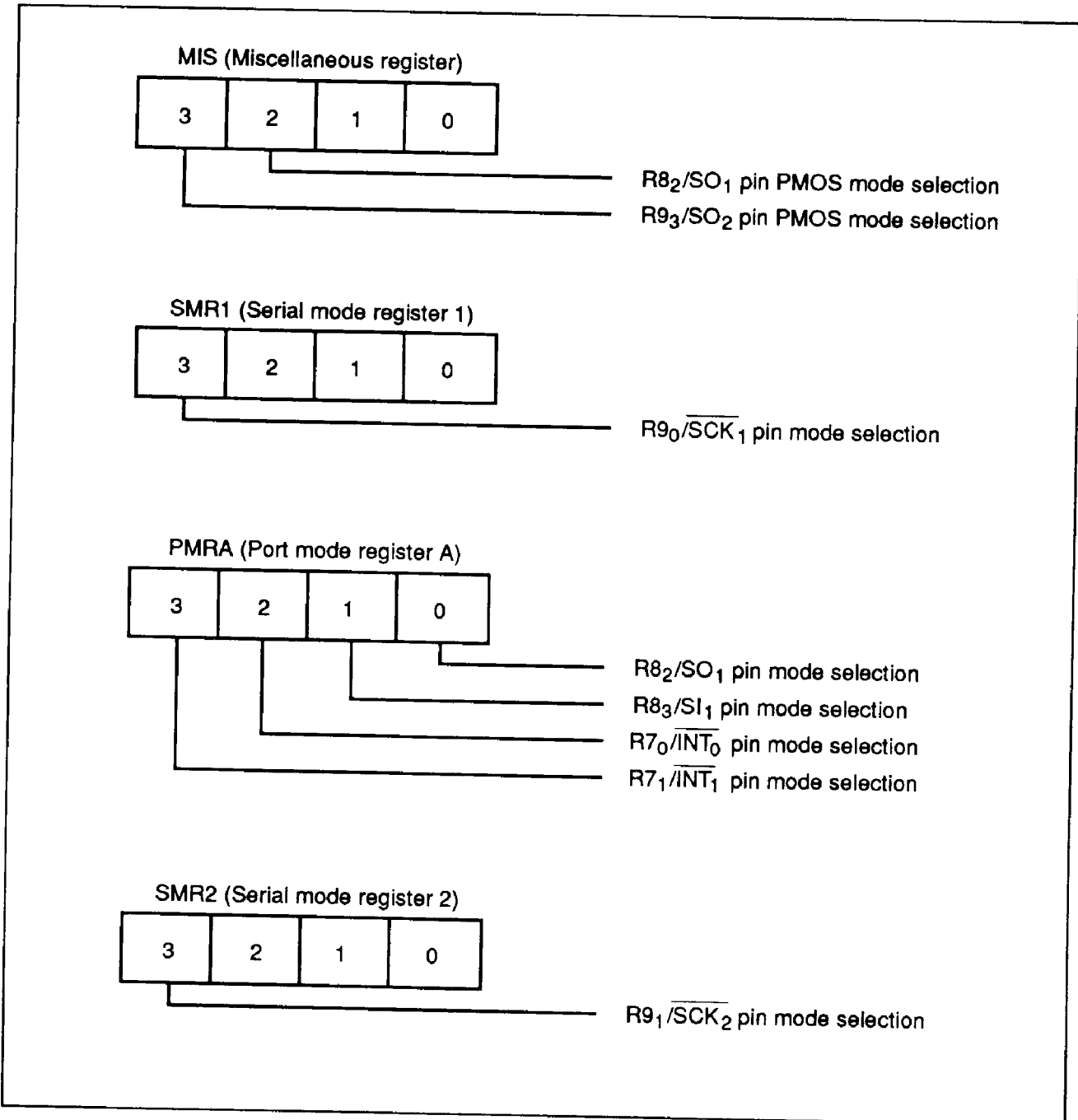

Figure 22 Pin Mode Selection Registers

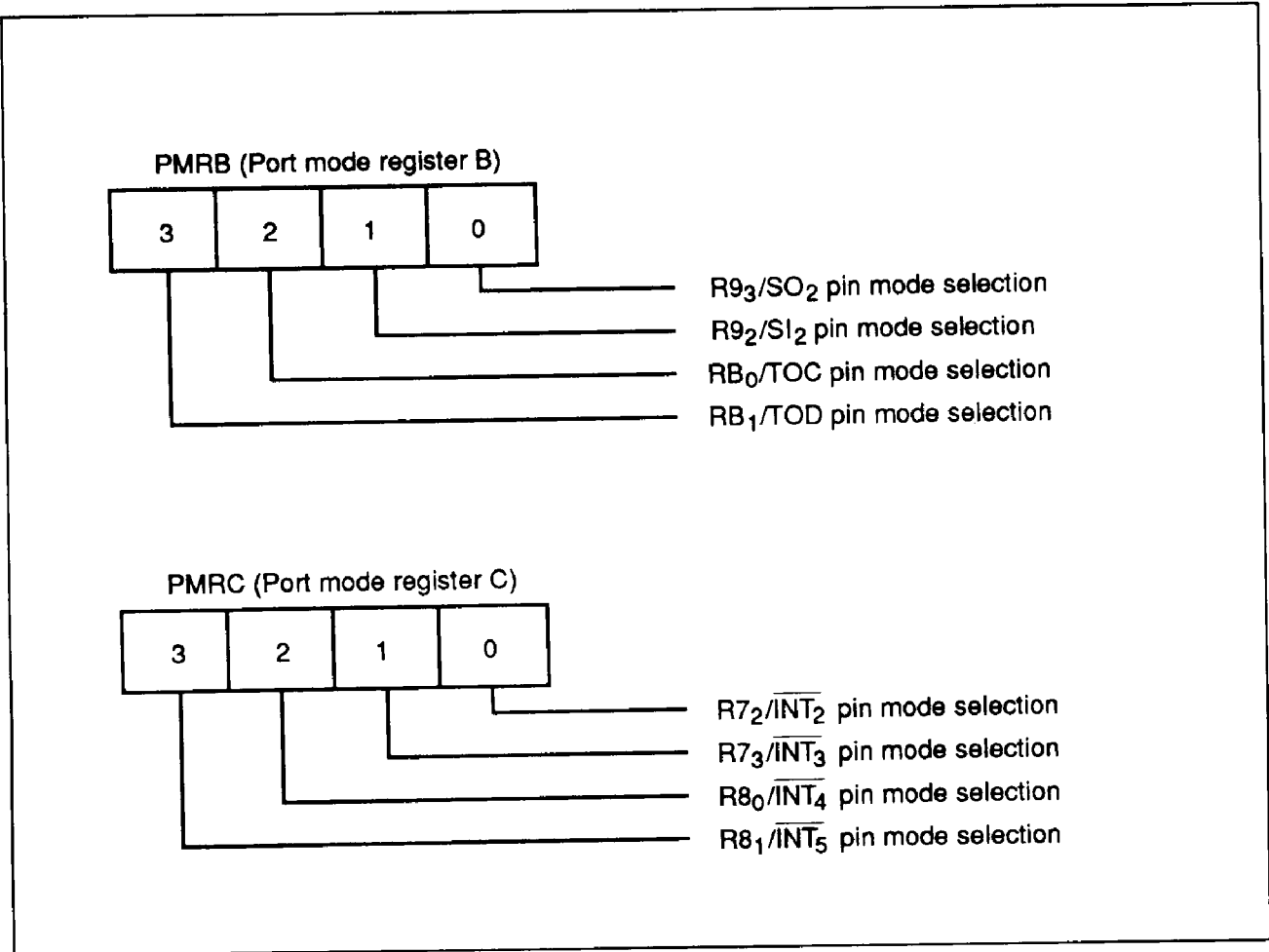

Figure 22 Pin Mode Selection Registers (cont)

## Timers

The MCU has two prescalers (S and W) and five timer/counters (A, B, C, D, and E). Block diagrams of the timers are shown in figures 23, 24, 26, and 29.

**Prescaler S:** Eleven-bit counter that inputs the system clock signal. After being initialized to \$000 by MCU reset, prescaler S divides the system

clock frequency. Only at MCU reset or during watch and stop modes does prescaler S stop counting.

**Prescaler W:** Five-bit counter that inputs the CL<sub>1</sub> input clock signal divided by 8. Prescaler W output can be selected as a timer A input clock by timer mode register A.

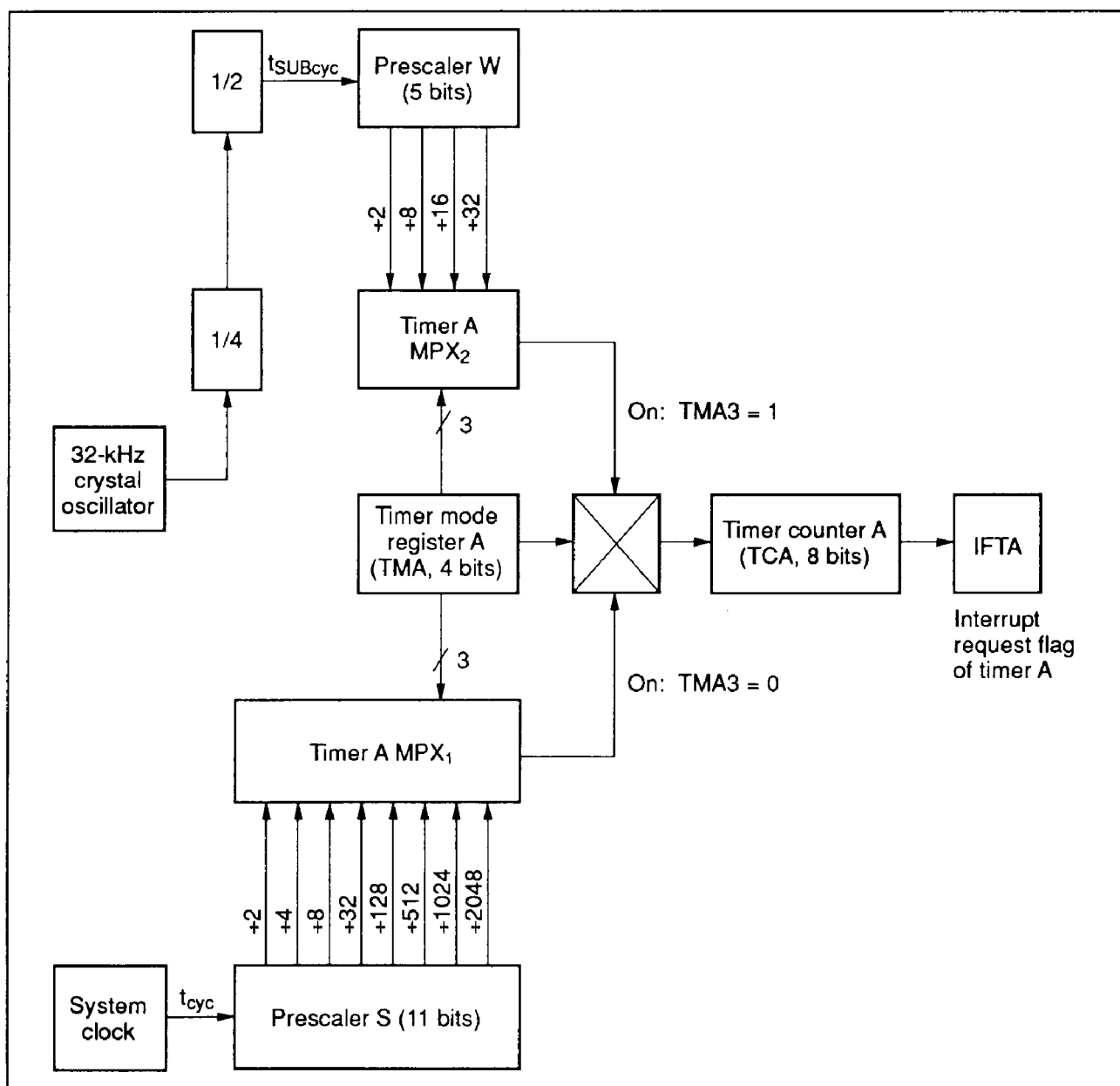

Figure 23 Block Diagram of Timer A

**Table 26 Timers A, B, and C Function Selection**

<b>Timer A</b>		<b>Timer B</b>	
<b>Condition</b>	<b>Function</b>	<b>Condition</b>	<b>Function</b>
TMA3 = 0	System clock-base interval timer	TMB2–TMB0 ≠ 111	Automatic reloading timer
TMA3 = 1	Clock time-base	TMB2–TMB0 = 111 and PMRA3 = 1	Event counter (Pin R7 <sub>1</sub> /INT <sub>1</sub> is specified as INT <sub>1</sub> )

<b>Timer C</b>	
<b>Condition</b>	<b>Function</b>
WDON = 0 (PMRB2 = 1)	Automatic reloading timer (Pin RB <sub>0</sub> /TOC is specified as TOC)
WDON = 1	Watchdog timer

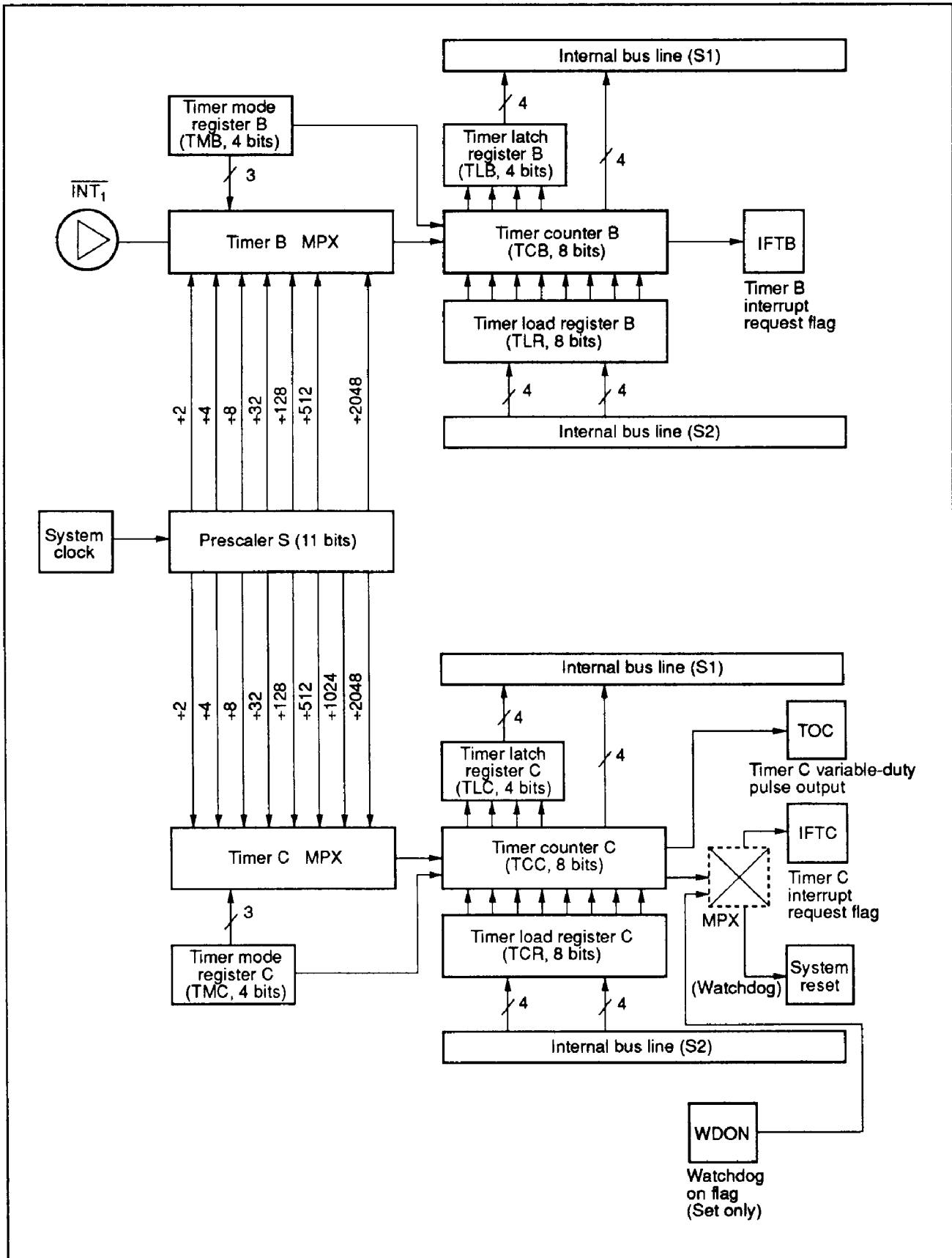

Figure 24 Block Diagram of Timers B and C



**Timer A:** Eight-bit timer which can be used as a clock time-base. Timer A is initialized to \$00 by reset, then incremented by each input clock. If an input clock is applied to timer A after it has reached \$FF, an overflow that sets the timer A interrupt request flag (IFTA: \$002, bit 2) is generated, and timer A restarts from \$00. Timer A is an interval timer which overflows every 256 clock inputs.

Timer A can also be used as a clock time-base when the TMA3 bit of timer mode register A (TMA) is set to 1. The timer is driven by the 32.768-kHz oscillator clock frequency divided by prescaler W. In this case, prescaler W and timer A can be initialized by software. The input clock of timer A is controlled by TMA.

**Timer B (TCBL: \$00A, TCBU: \$00B, TLRL: \$00A, TLRU: \$00B):** Eight-bit write-only timer load register (TLRL and TLRU) and read-only timer counter (TCBL and TCBU) located at the same address. The eight-bit configuration consists of lower and upper digits located at sequential addresses.

Timer counter B is initialized by writing data to timer load register B (TLR). In this case, the lower digit must be written first. Both the upper and lower digits of TLR are loaded into the timer counter at the same time the upper digit is written to TLR. TLR is initialized to \$00 by MCU reset.

The count of timer B is obtained by reading timer counter B. In this case, the upper digit must be read first; the count is latched at the same time the upper digit is read.

An automatic reloading function, input clock source, and prescaler division ratio of timer B are selected by timer mode register B (TMB). When an external event input is used as the input clock source of timer B, the  $R7_1/\overline{INT}_1$  pin must be specified as the  $\overline{INT}_1$  pin by port mode register A (PMRA: \$004) and the external interrupt mask (IM1) must be set to inhibit any  $\overline{INT}_1$  interrupt request.

Timer B is initialized to the value set in timer load register B (TLR) by software, and is then incremented by one every clock input. If an input clock

is applied to timer B after it has reached \$FF, an overflow is generated. In this case, if the automatic reloading function is enabled, timer B is initialized to its initial value; if reloading is disabled, the timer is initialized to \$00. The overflow sets the timer B interrupt request flag (IFTB: \$003, bit 0).

**Timer C (TCCL: \$00E, TCCU: \$00F, TCRL: \$00E, TCRU: \$00F):** Eight-bit write-only timer load register (TCRL and TCRU) and read-only timer counter (TCCL and TCCU) located at the same address. The eight-bit configuration consists of lower and upper digits located at sequential addresses. The operation of timer C is basically the same as that of timer B.

An automatic reloading function and prescaler division ratio of timer C depend on the state of timer mode register C (TMC). Timer C is initialized to the value set in the TMC by software, and is then incremented by one every clock input. If an input clock is applied to timer C after it has reached \$FF, an overflow is generated. In this case, if the automatic reloading function is enabled, timer C is initialized to its initial value; if the function is disabled, the timer is initialized to \$00. The overflow sets the timer C interrupt request flag (IFTC: \$003, bit 2).

Timer C also functions as a watchdog timer. The watchdog timer functions while the watchdog on (WDON) flag is set, and the MCU is reset by an overflow from timer C. If a program routine goes out of control, it can be detected by controlling the timer C reset before the count has reached \$FF. Only a 1 can be written to the watchdog on flag. It can be cleared to 0 only by an MCU reset; it cannot be cleared by writing 0.

Timer C has a variable-duty pulse output (TOC) whose output waveform depends on the status of timer mode register C (TMC) and timer load register C (TCR) as shown in figure 25. For pulse output, the  $RB_0/TOC$  pins must be specified as TOC by port mode register B (PMRB).

**Timer Mode Register A (TMA: \$008):** Four-bit write-only register which controls timer A as shown in table 27. It is initialized to \$0 by MCU reset.

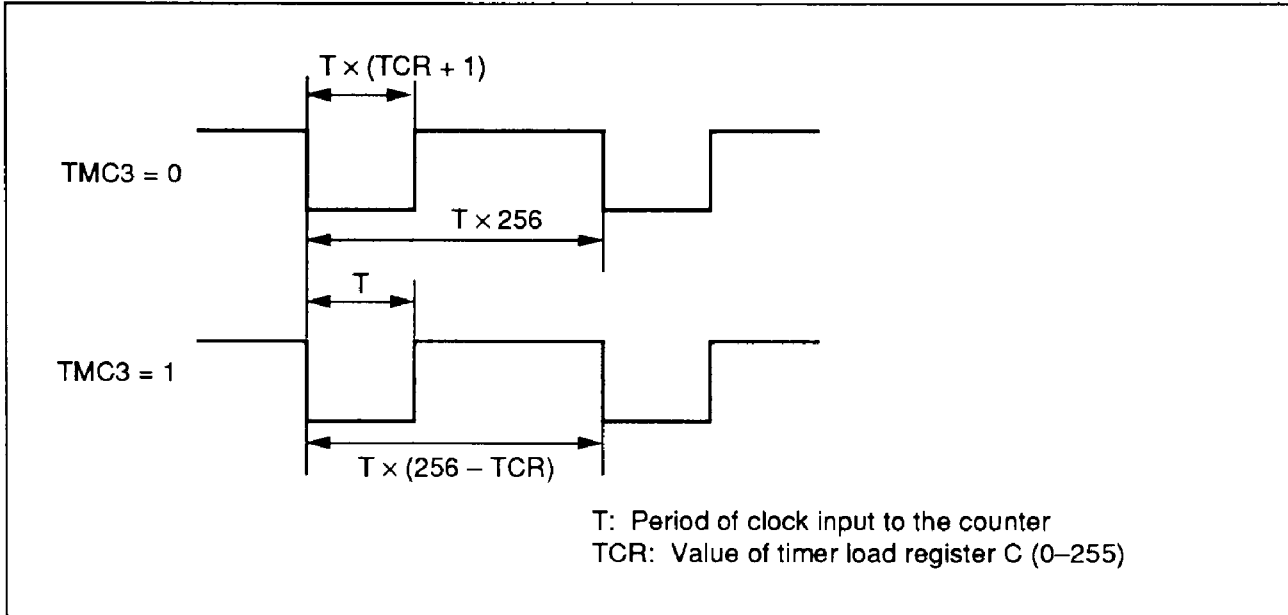

Figure 25 Variable-Duty Pulse Output Waveform

Table 27 Timer Mode Register A

TMA				Source Prescaler, Input Clock Period, Operating Mode	
Bit 3	Bit 2	Bit 1	Bit 0		
0	0	0	0	PSS, 2048 $t_{cyc}$	Timer A mode
			1	PSS, 1024 $t_{cyc}$	
		1	0	PSS, 512 $t_{cyc}$	
			1	PSS, 128 $t_{cyc}$	
	1	0	0	PSS, 32 $t_{cyc}$	
			1	PSS, 8 $t_{cyc}$	
		1	0	PSS, 4 $t_{cyc}$	
			1	PSS, 2 $t_{cyc}$	
1	0	0	0	PSW, 32 $t_{SUBcyc}$	Time-base mode
			1	PSW, 16 $t_{SUBcyc}$	
		1	0	PSW, 8 $t_{SUBcyc}$	
			1	PSW, 2 $t_{SUBcyc}$	
	1	0	0	PSW, TCA reset	
			1		
		1	0		
			1		

- Notes: 1.  $t_{SUBcyc} = 244.14 \mu s$  (when a 32.768-kHz crystal oscillator is used)  
 2.  $t_{cyc} = 0.9536 \mu s$  (when a 4.1943-MHz crystal oscillator is used)  
 3. Timer counter overflow output period(s) = Input clock period(s)  $\times$  256

**Timer Mode Register B (TMB: \$009):** Four-bit write-only register which selects the automatic reloading function, input clock source, and the prescaler division ratio for timer B as shown in table 28. It is initialized to \$0 by MCU reset.

Changes made to TMB are valid from the second instruction cycle after the write instruction is executed. Timer B must be programmed so that it is initialized by a write instruction to timer load register B (TLR) after a mode change becomes valid.

**Table 28 Timer Mode Register B**

**TMB**

Bit 3	Automatic Reloading
0	Disabled
1	Enabled

TMB			Input Clock Period and Input Clock Source
Bit 2	Bit 1	Bit 0	
0	0	0	2048 $t_{cyc}$
0	0	1	512 $t_{cyc}$
0	1	0	128 $t_{cyc}$
0	1	1	32 $t_{cyc}$
1	0	0	8 $t_{cyc}$
1	0	1	4 $t_{cyc}$
1	1	0	2 $t_{cyc}$
1	1	1	$\overline{INT}_1$ (external event input)

Note:  $t_{cyc} = 0.9536 \mu s$  (when a 4.1943-MHz crystal oscillator with 1/4 division is used)

**Timer Mode Register C (TMC: \$00D):** Four-bit write-only register which selects the automatic reloading function and the prescaler division ratio for timer C as shown in table 29. It is initialized to \$0 by MCU reset.

Changes made to TMC are valid from the second instruction cycle after the write instruction is executed. Timer C must be programmed so that it is initialized by a write instruction to timer load register C (TCR) after a mode change becomes valid.

---

**Table 29 Timer Mode Register C**

TMC	
Bit 3	Automatic Reloading
0	Disabled
1	Enabled

TMC			
Bit 2	Bit 1	Bit 0	Input Clock Period
0	0	0	2048 $t_{cyc}$
0	0	1	1024 $t_{cyc}$
0	1	0	512 $t_{cyc}$
0	1	1	128 $t_{cyc}$
1	0	0	32 $t_{cyc}$
1	0	1	8 $t_{cyc}$
1	1	0	4 $t_{cyc}$
1	1	1	2 $t_{cyc}$

Note:  $t_{cyc} = 0.9536 \mu s$  (when a 4.1943-MHz crystal oscillator with 1/4 division is used)

**Timer D (TCDL: \$011, TCDU: \$012, TDRL: \$011, TDRU: \$012):** Eight-bit write-only timer load register (TDRL and TDRU) and read-only timer counter (TCDL and TCDU) located at the same address. The eight-bit configuration consists of lower and upper digits located at sequential addresses.

An automatic reloading function and prescaler division ratio of timer D are selected by timer mode register D (TMD). Timer D is initialized to the value set in timer load register D (TDR) by software, and is then incremented by one every clock input. If an input clock is applied to timer D after it has reached \$FF, an overflow is generated. In this case, if the automatic reloading function is enabled, timer D is initialized to its initial value; if reloading is disabled, the timer is initialized to \$00. The overflow sets the timer D interrupt request flag (IFTD: \$021, bit 0).

Timer D has a variable-duty pulse output (TOD), whose output waveform depends on the states of timer mode register D (TMD) and timer load register D (TDR) as shown in figure 27. For pulse output, the RB<sub>1</sub>/TOD pin must be specified as TOD by port mode register B (PMRB).

**Timer Mode Register D (TMD: \$010):** Four-bit write-only register which selects the automatic reloading function and the prescaler division ratio for timer D as shown in figure 28. It is initialized to \$0 by MCU reset.

Changes made to TMD are valid from the second instruction cycle after the write instruction is executed. Timer D must be programmed so that it is initialized by a write instruction to timer load register D (TDR) after a mode change becomes valid.

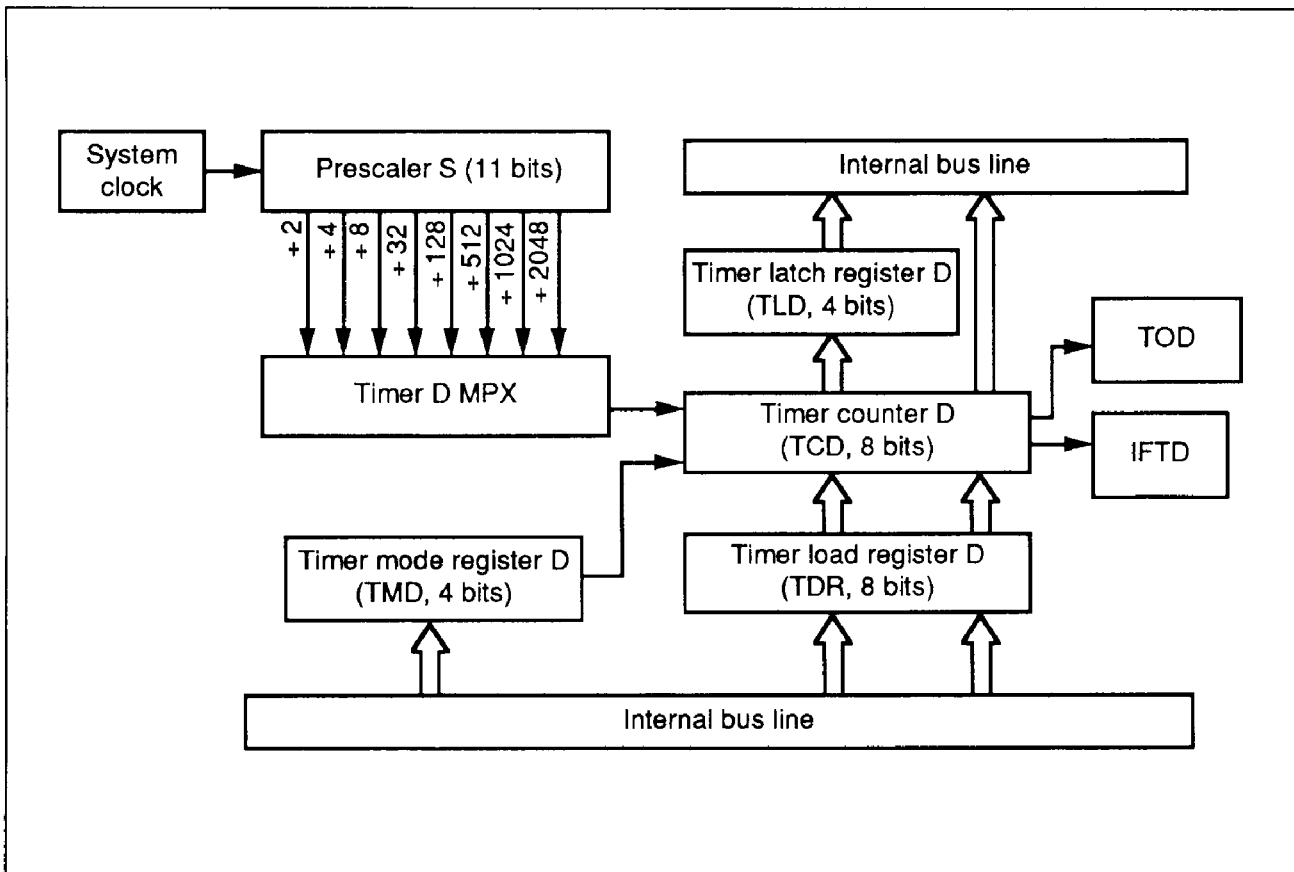

Figure 26 Block Diagram of Timer D

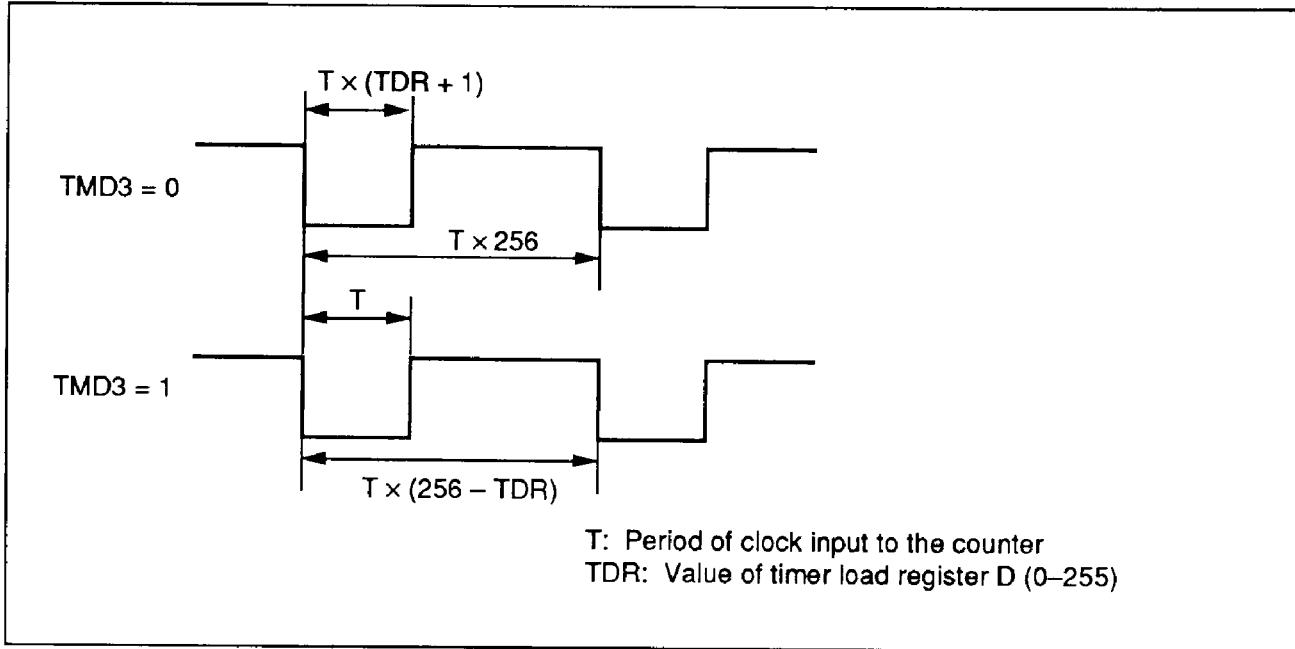

Figure 27 Variable-Duty Pulse Output Waveform

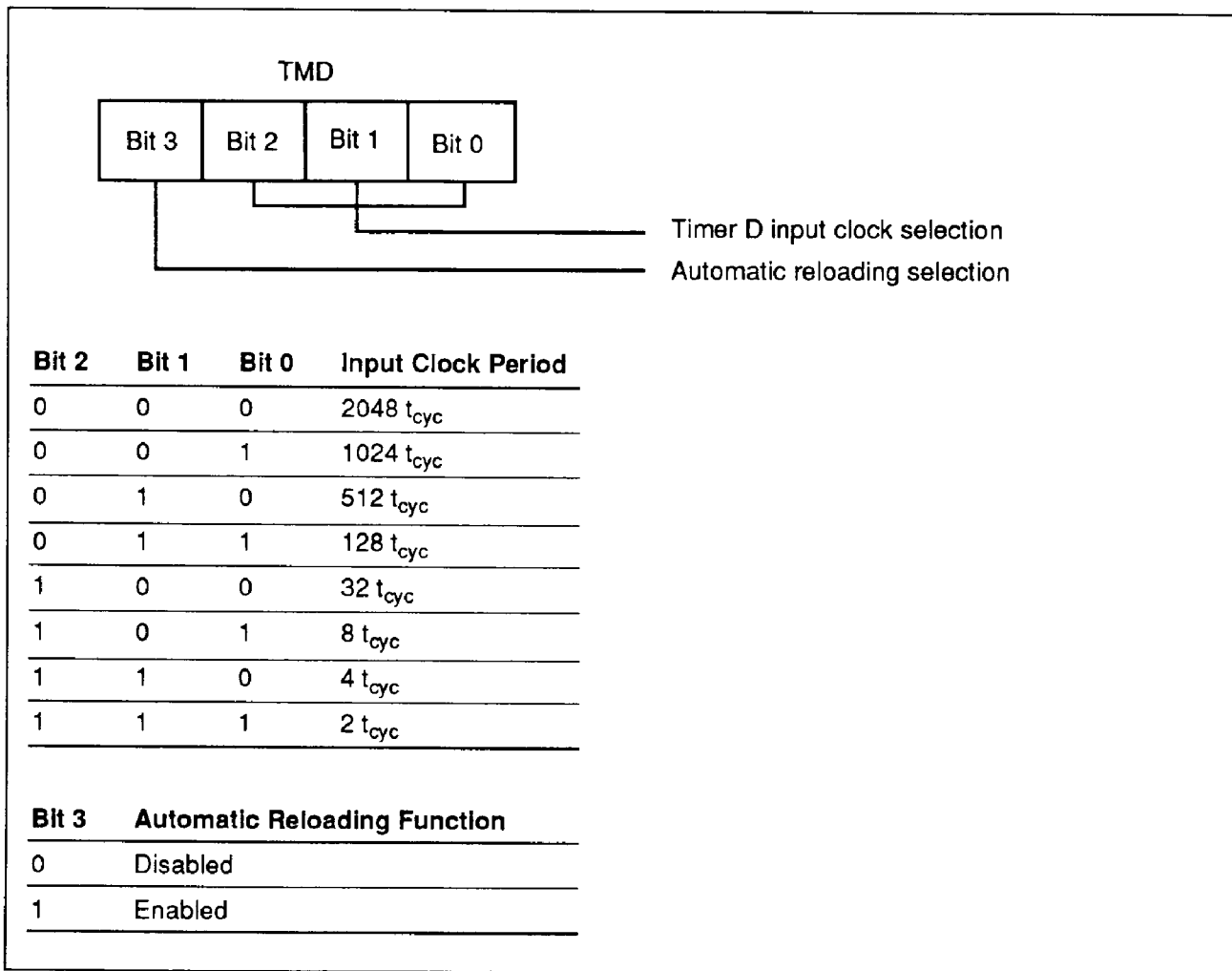

Figure 28 Timer Mode Register D



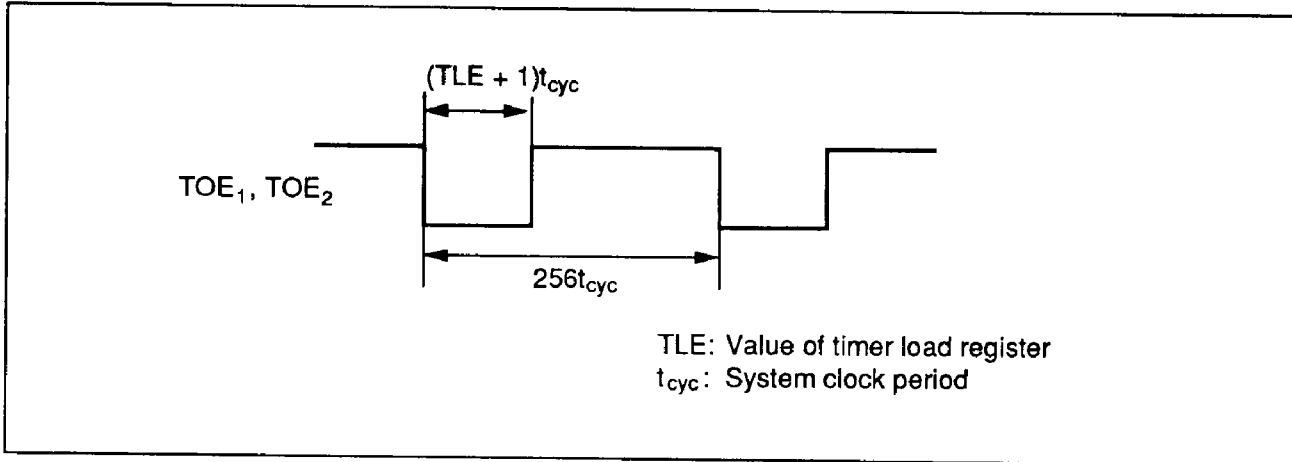

Figure 30 Variable-Duty Pulse Output Waveform

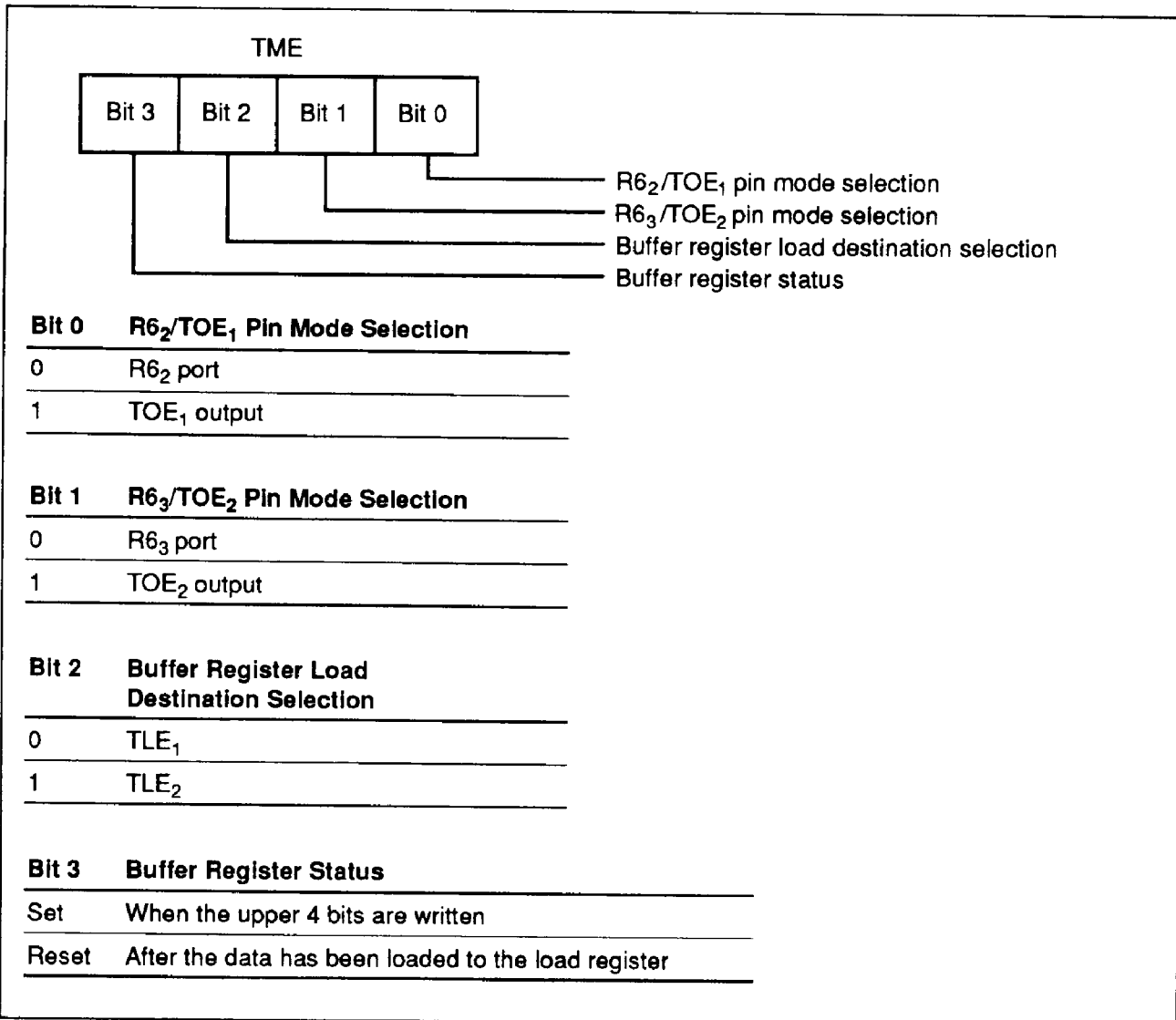

Figure 31 Timer Mode Register E



**Input Capture Timer:** Eight-bit counter and 8-bit input capture register. Free-running counter operation or input capture operation can be selected by setting the input capture status register.

When the free-running counter operation is selected, the counter is incremented by one every prescaler clock input, whose division ratio is specified by the input capture control register. If an overflow is generated from the counter, the input capture interrupt request flag is set, and the counter is initialized to \$00. It is then incremented.

When the input capture operation is selected, the count of the 8-bit counter is loaded into the input capture register by every trigger edge input of ICT<sub>0</sub> or ICT<sub>1</sub>. At this point, the input capture interrupt request flag and input capture status flag are set and the counter is initialized to \$00, and is

then incremented. An external trigger input while the status flag is 1 or an overflow from the counter (when the counter continues to increment without receiving trigger input) sets bit 3 of the status register.

**Input Capture Control Register (ICC: \$017):** Four-bit write-only register which selects the pin function and the prescaler division ratio.

**Input Capture Status Register (ICSR: \$018):** Four-bit register which selects the input capture operation and the trigger input edge, and holds the operation status.

**Input Capture Register (ICRL: \$019, ICRU: \$01A):** Eight-bit read-only register which loads the contents of the counter by a trigger edge input of ICT<sub>0</sub> or ICT<sub>1</sub>.

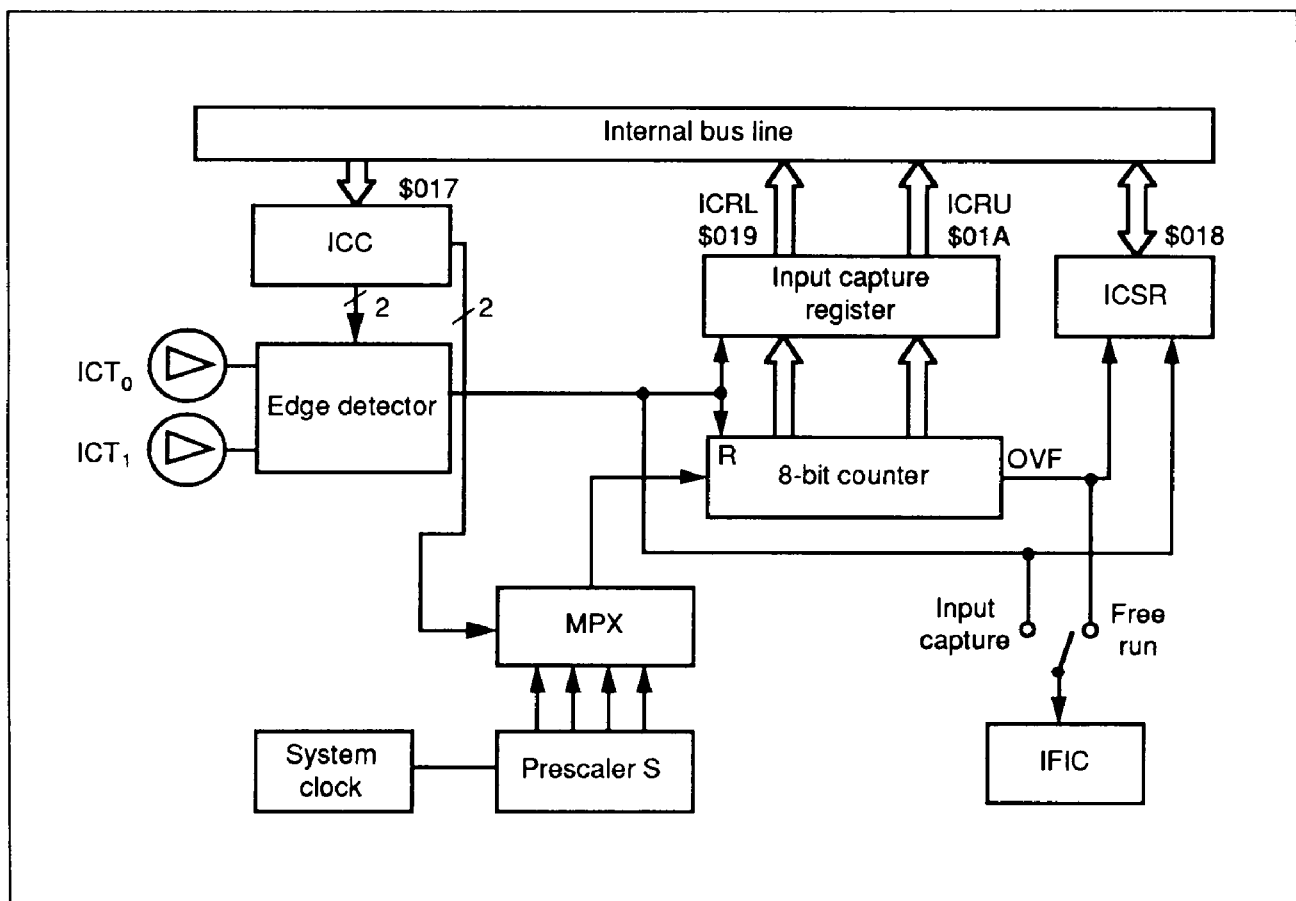
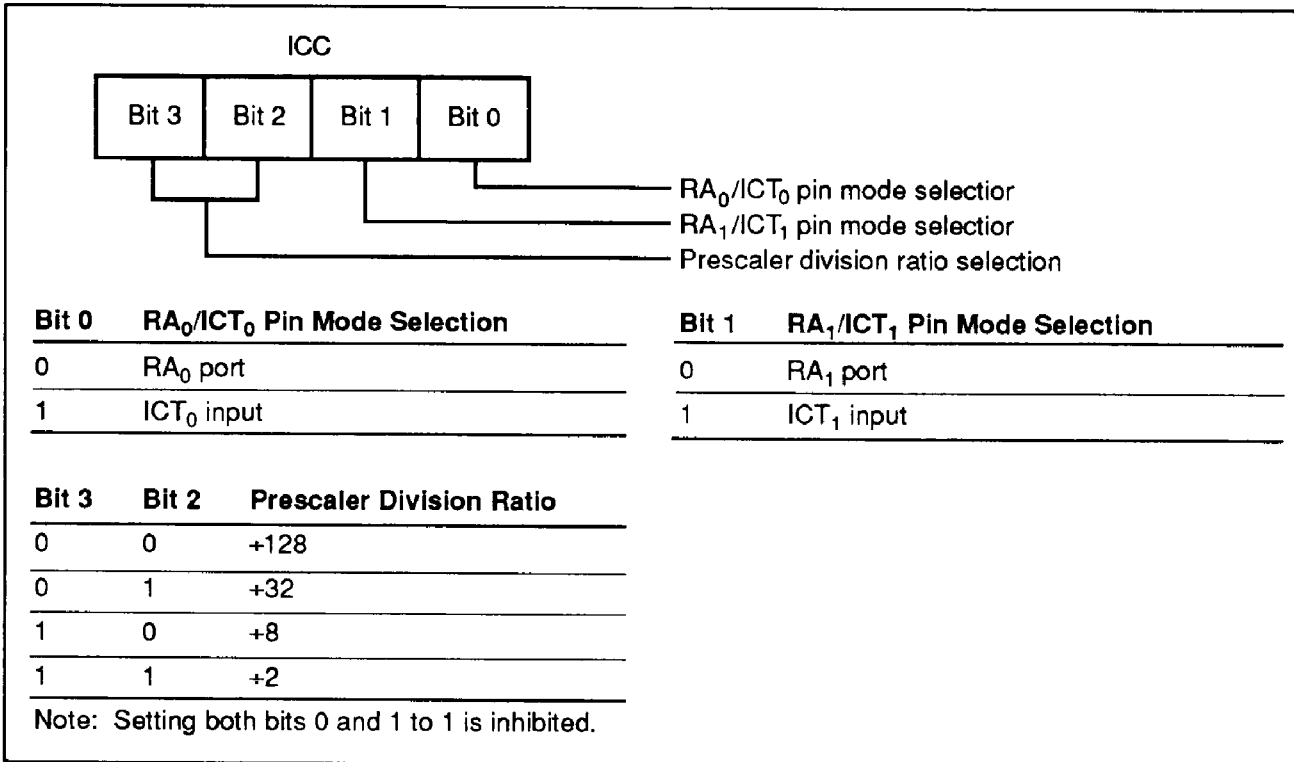
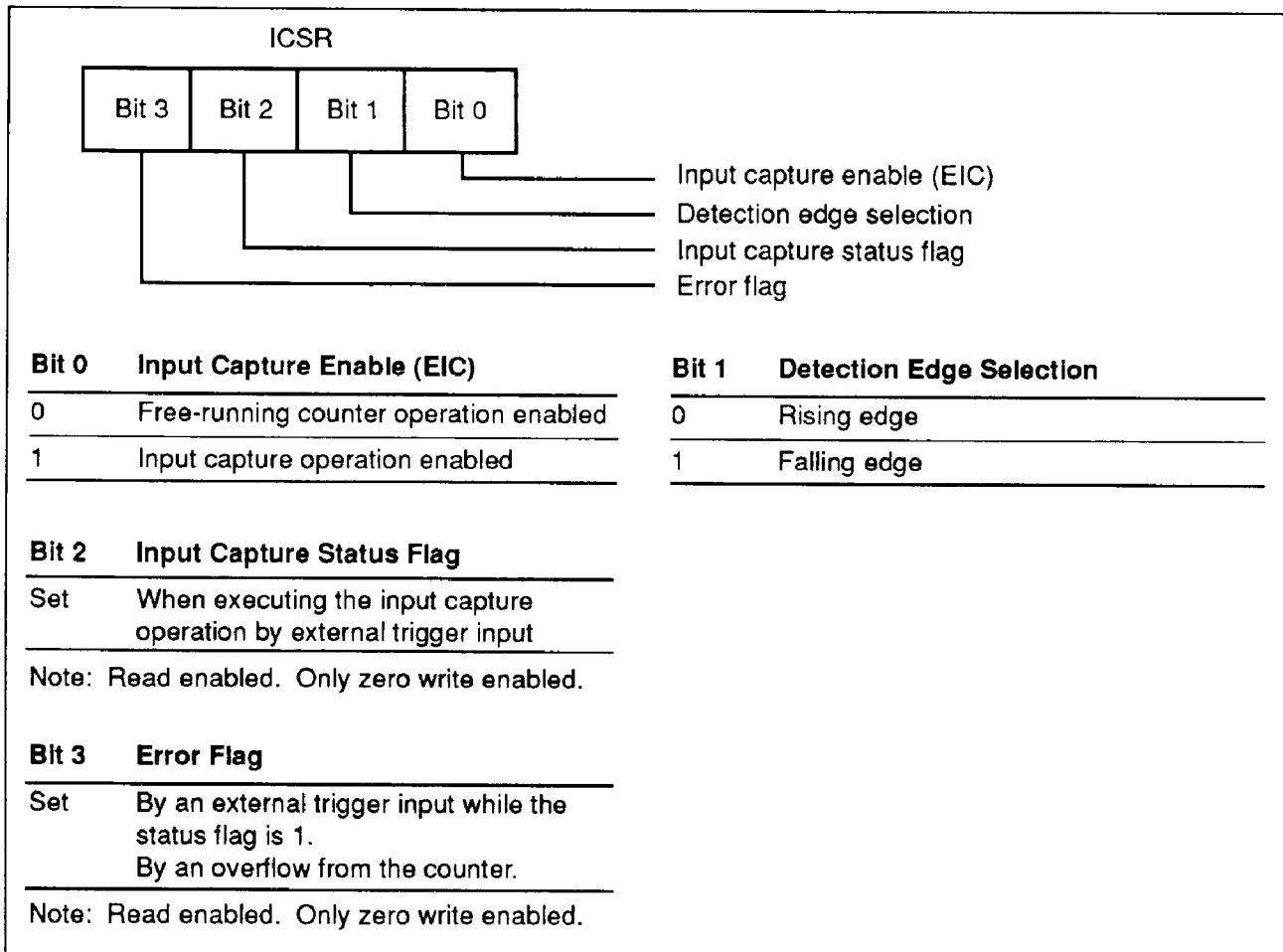

Figure 32 Block Diagram of Input Capture Timer



**Figure 33 Input Capture Control Register**



**Figure 34 Input Capture Status Register**

**Output Compare Timer:** A 16-bit counter and 16-bit register. The output compare timer outputs a wave whose form changes at a specified timing. This timing to change the waveform can be selected as an overflow from the 16-bit counter, an input edge of  $\overline{INT}_4$ , or a trigger by software. An output of 1, an output of 0, or a toggle (inversion of the previous output value) can be selected as the output of pin TOG.

Timer counter G, the counter for output compare, is a 16-bit counter. The system clock or the system clock divided by 2 can be selected as the clock source. Timer counter G is a reloading counter. At

the time of a counter overflow, an  $\overline{INT}_4$  edge input, or a software trigger, the contents of timer load register G are loaded into timer counter G. An output compare interrupt is generated at the falling edge of  $\overline{INT}_4$  or a counter overflow, depending on the selection set with bit 3 of the output compare control register.

When selecting a software trigger, set both bits 2 and 3 of the output compare control register to 1. At the same time the bits are set, pin TOG outputs a specified value and the contents of the load register are loaded into the counter.

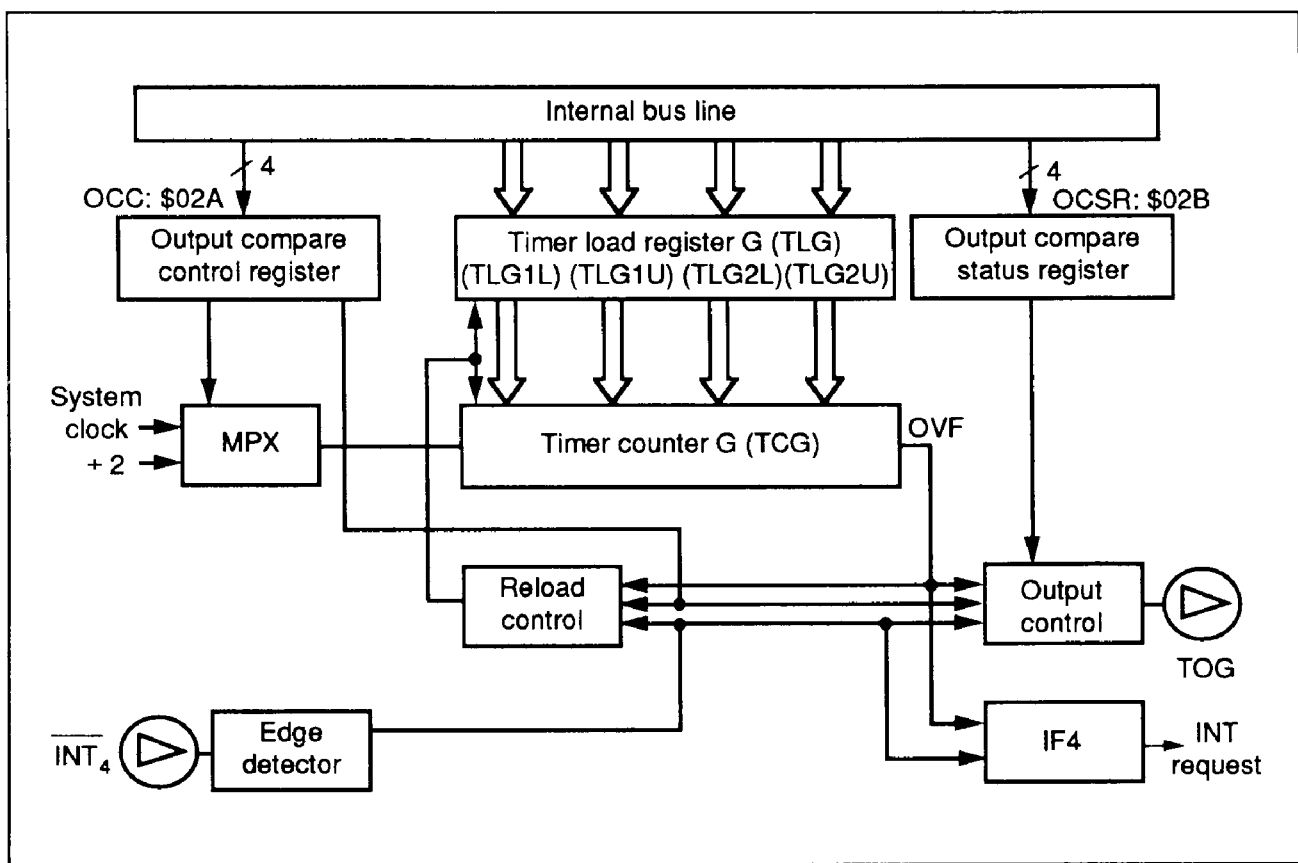

Figure 35 Block Diagram of Output Compare Timer

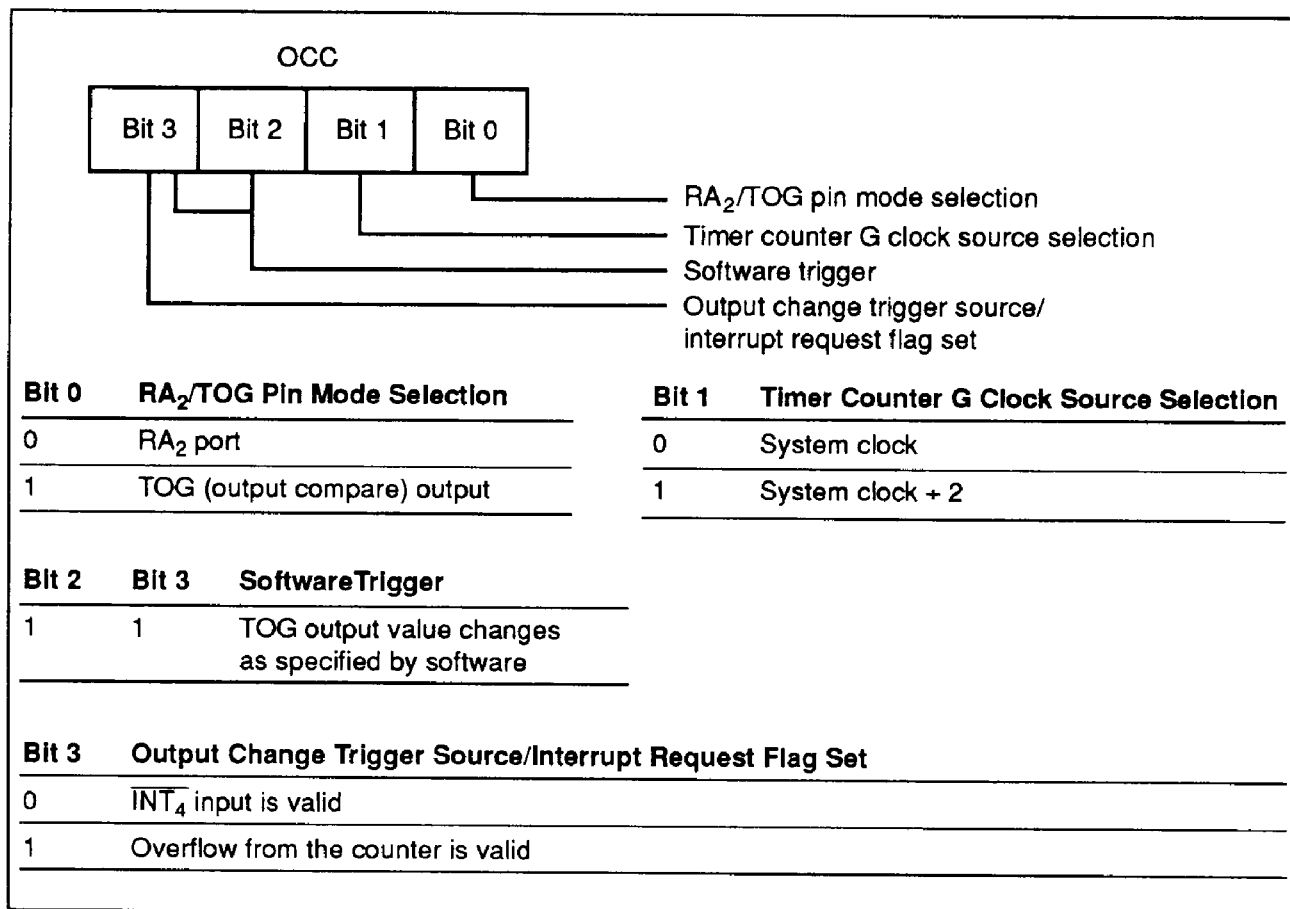

Figure 36 Output Compare Control Register

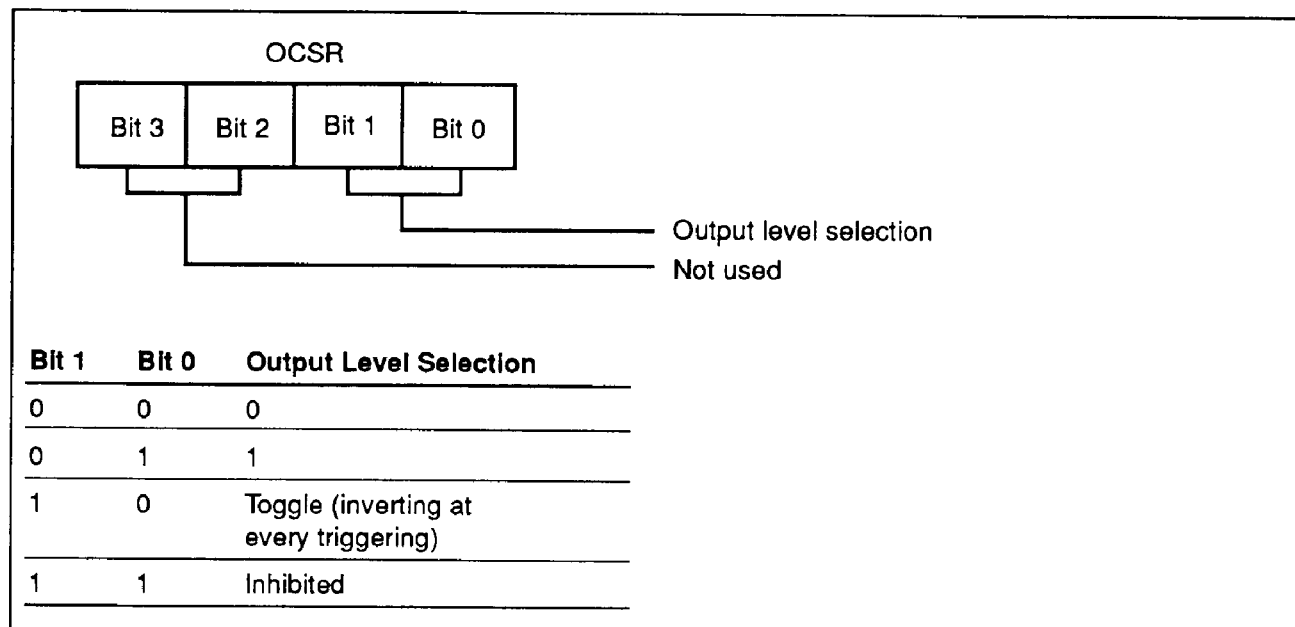

Figure 37 Output Compare Status Register

**Buzzer Output Function:** Outputs a wave which has a duty ratio of 50% of the clock rate specified by the buzzer control register (BCR). To output a buzzer, the RA<sub>3</sub>/BUZZ pin must be fixed as BUZZ by setting bit 3 of the buzzer control register.

**Buzzer Control Register (BCR: \$029):** Four-bit write-only register which selects the port and the output wave frequency.

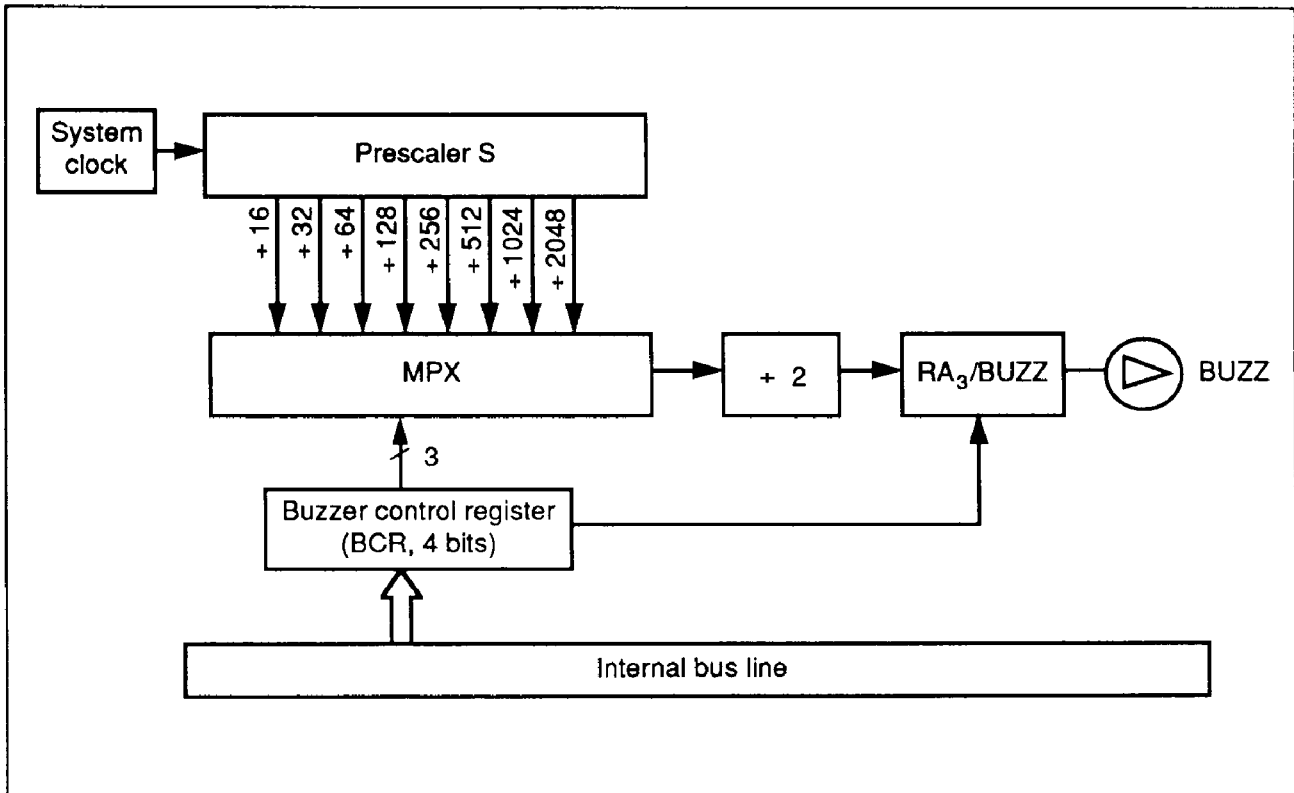
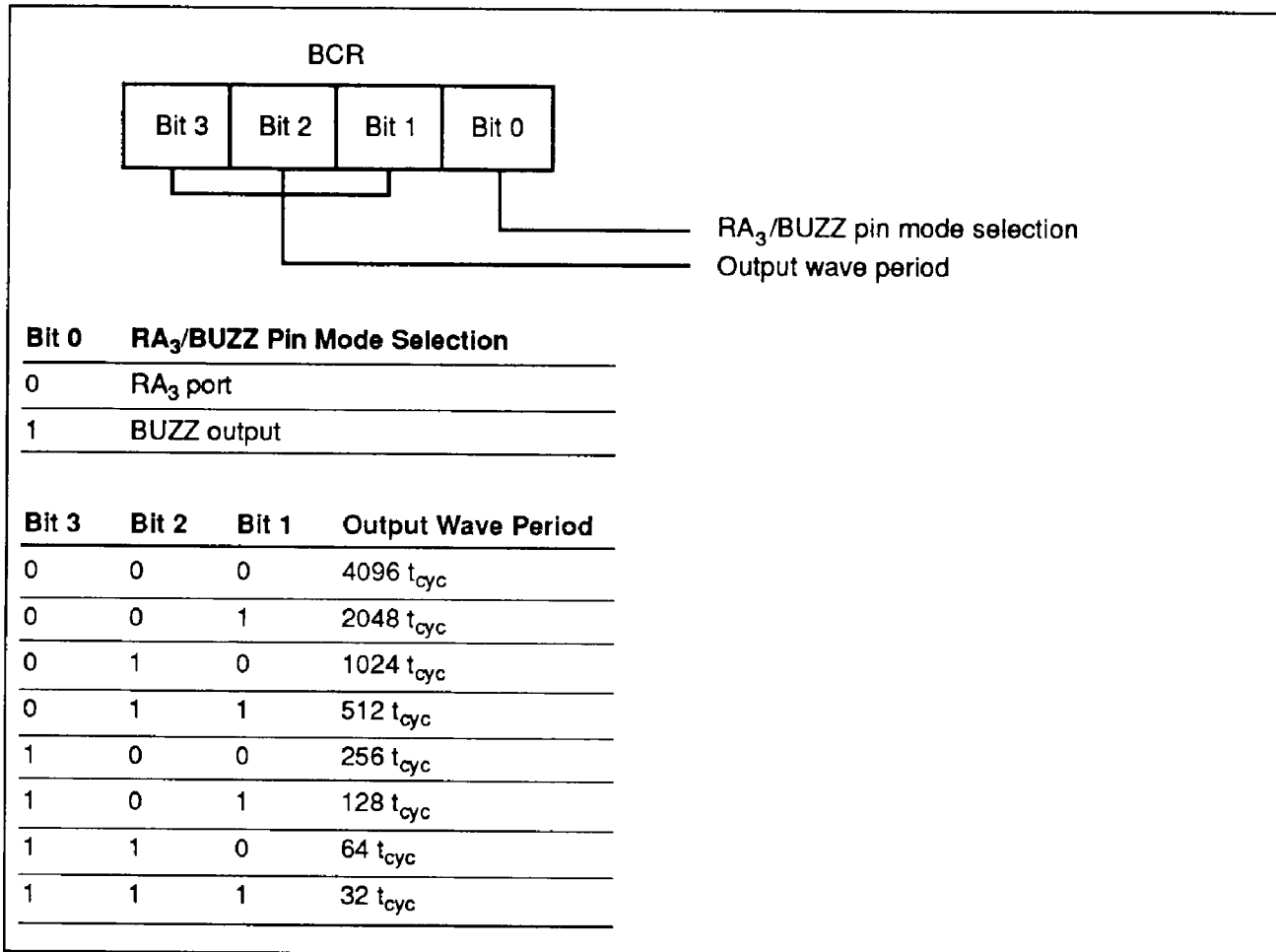

Figure 38 Block Diagram of Buzzer Output



**Figure 39 Buzzer Control Register**

### Serial Interface

The MCU has two clock-synchronous 8-bit serial interfaces (serial interface 1 and serial interface 2). The clock source is a prescaler, which is also used by the timers.

**Serial Interface 1:** Used to serially transmit and receive 8-bit data. It consists of serial data register 1 (SR1), serial mode register 1 (SMR1), port mode register A (PMRA), an octal counter, and a multiplexer as shown in figure 40. The R9<sub>0</sub>/SCK<sub>1</sub> pin and the transmit clock are controlled by writing data to SMR1. The transmit clock shifts the con-

tents of SR1, which can be read and written to by software. In this way, 8-bit data is transferred.

Serial interface 1 is activated by the STS instruction. The octal counter is reset to \$0 by the STS instruction, it starts counting at the falling edge of the transmit clock (SCK<sub>1</sub>), and it increments at the rising edge of the clock. When the eighth transmit clock signal is input (serial interface 1 is reset) or when serial transmission is discontinued (octal counter is reset), the serial 1 interrupt request flag (IFS1) is set.

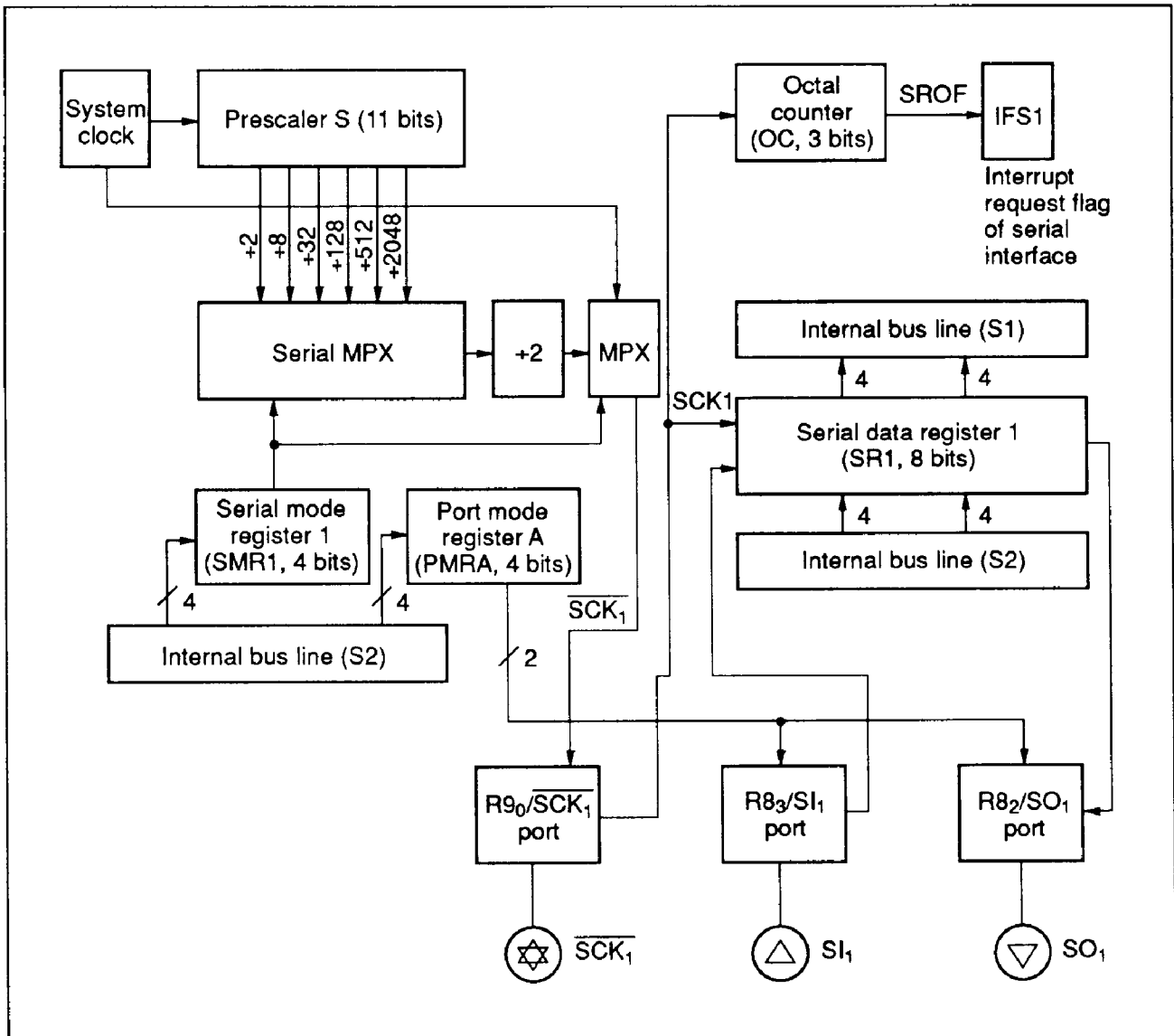

Figure 40 Serial Interface 1 Block Diagram

**Serial Mode Register 1 (SMR1: \$005):** Four-bit write-only register which controls the  $R9_0/\overline{SCK}_1$  pin, transmit clock, and prescaler division ratio for serial interface 1 as shown in figure 41. Writing to SMR1 initializes serial interface 1.

A write signal input to SMR1 discontinues the input of the transmit clock to serial data register 1 (SR1) and the octal counter. Therefore, if a write occurs during data transmission, the octal counter

is reset to \$0 to stop transmission, and, at the same time, the serial 1 interrupt request flag (IFS1) is set.

The contents of the serial mode register are not valid until the second instruction cycle after the write instruction execution. The user must program the STS instruction to be executed after this instruction cycle. The serial mode register is initialized to \$0 by MCU reset.

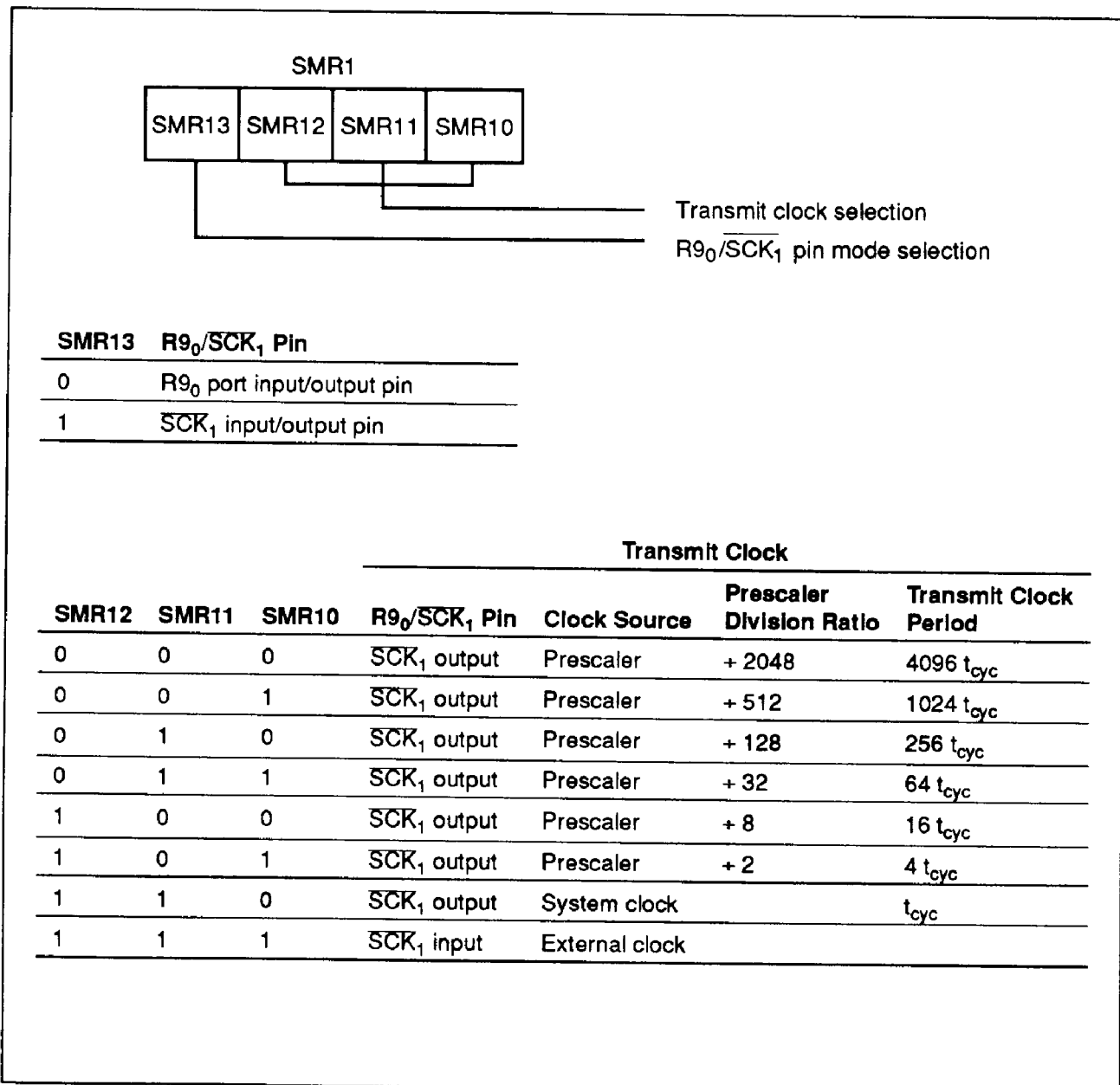

Figure 41 Serial Mode Register 1



**Serial Data Register 1 (SR1L: \$006, SR1U: \$007):** Eight-bit read/write register separated into lower and upper digits located at sequential addresses. Data in this register is output from the SO<sub>1</sub> pin LSB first, synchronously with the falling edge of the transmit clock, and data is input to the LSB first through the SI<sub>1</sub> pin at the rising edge of the transmit clock. Input/output timing is shown in figure 42.

Data cannot be read or written during serial data transmission. If data is read or written during transmission, it cannot be guaranteed.

**Selecting and Changing Operating Modes:** The operating modes of serial interface 1 are shown in table 30. The combination of port mode register A (PMRA) and serial mode register 1 (SMR1) must be specified as shown in the table. To change the operating mode of serial interface 1, internally initialize serial interface 1 by writing to SMR1.

**Table 30 Operating Modes of Serial Interface 1**

SMR1 Bit 3	PMRA		Operating Mode
	Bit 1	Bit 0	
1	0	0	Continuous clock output mode
1	0	1	Transmit mode
1	1	0	Receive mode
1	1	1	Transmit/receive mode

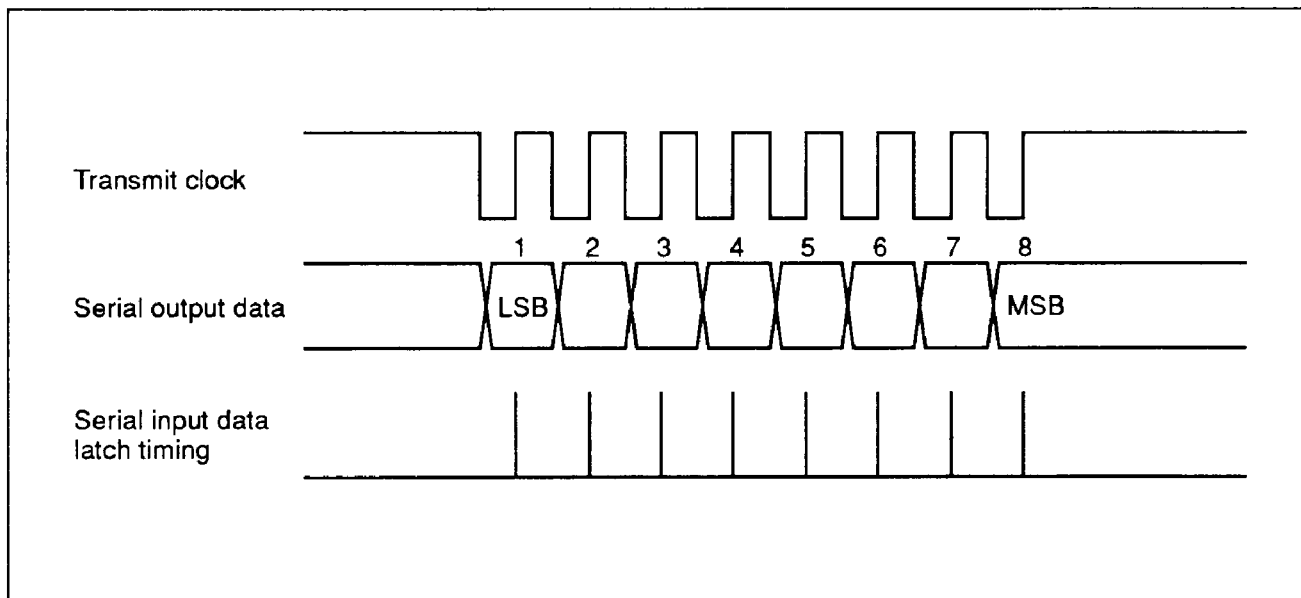

**Figure 42 Serial Interface 1 Timing**

**Serial Interface 1 Operation:** Three operating modes are provided for serial interface 1; transitions between them are shown in figure 43.

In STS wait state, serial interface 1 is initialized and the transmit clock is ignored. If the STS instruction is then executed, serial interface 1 enters transmit clock wait state.

In transmit clock wait state, input of the transmit clock increments the octal counter, shifts serial data register 1 (SR1), and starts serial transmission. However, note that if continuous clock output mode is selected, the transmit clock is continuously output, but data is not transmitted.

During transmission, the input of eight clocks or the execution of the STS instruction sets the octal counter to 000, and serial interface 1 enters transmit clock wait state. If an external transmit clock is further applied, serial interface 1 enters the transfer state. In this state, if the internal clock has been selected, the serial 1 interrupt flag is set, serial interface 1 enters STS instruction wait state, and serial transmission is stopped after the eighth clock is output.

If port mode register A (PMRA) is written to in transmit clock wait state or during transmission, serial mode register 1 (SMR1) must be written to, to initialize serial interface 1, after which serial interface 1 enters STS wait state.

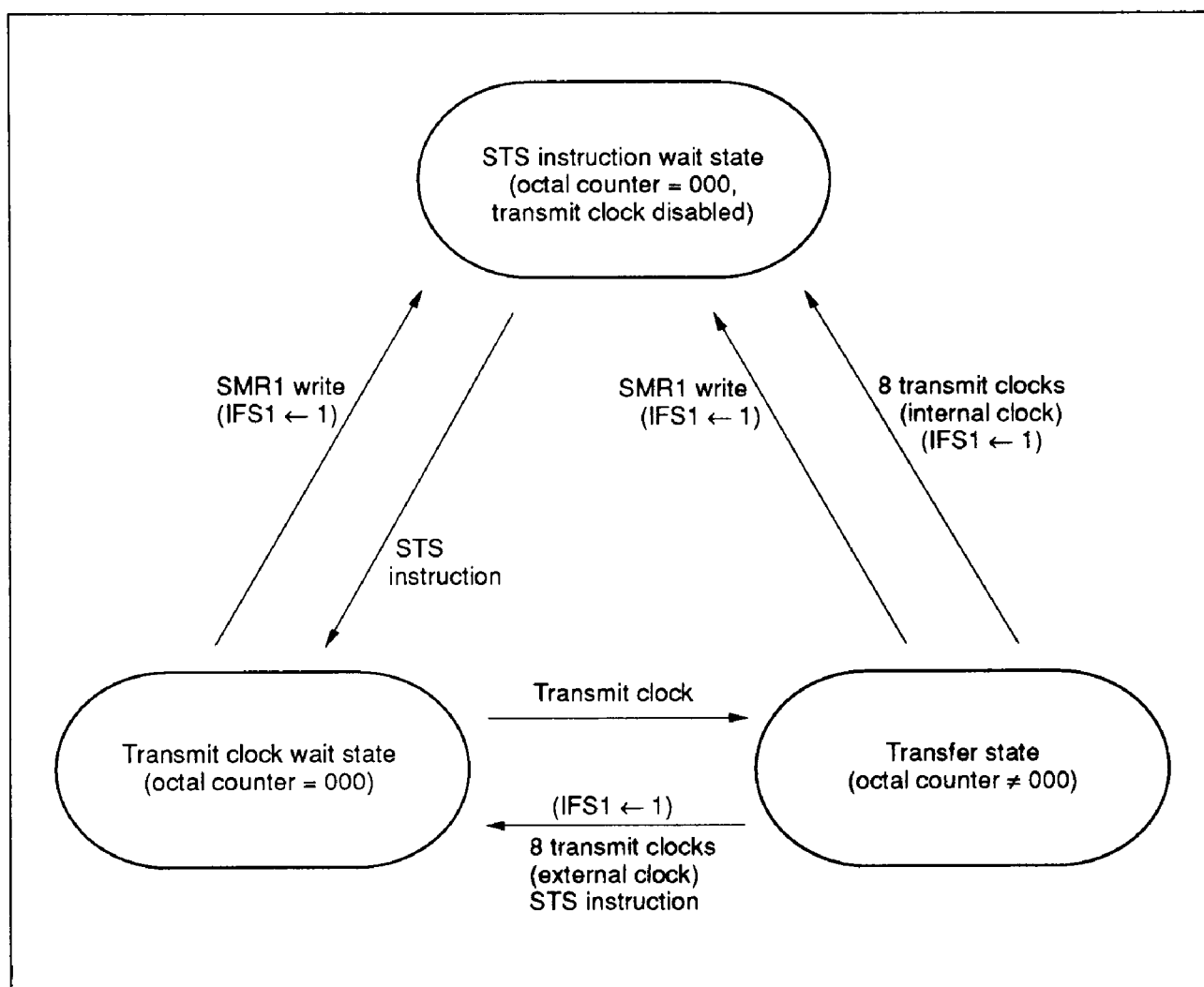

**Figure 43 Serial Interface 1 Mode Transitions**

**Transmit Clock Error Detection:** Serial interface 1 will malfunction if a spurious pulse caused by external noise conflicts with a normal transmit clock. Such errors can be detected as shown in figure 44.

If more than eight transmit clocks are input in transmit clock wait state, serial interface 1's state

changes to transfer state, transmit clock wait state, then back to transfer state.

When serial interface 1 is set to STS wait state by writing data to SMR1 during transmission after the serial 1 interrupt request flag (IFS1) has been reset, the flag is set again.

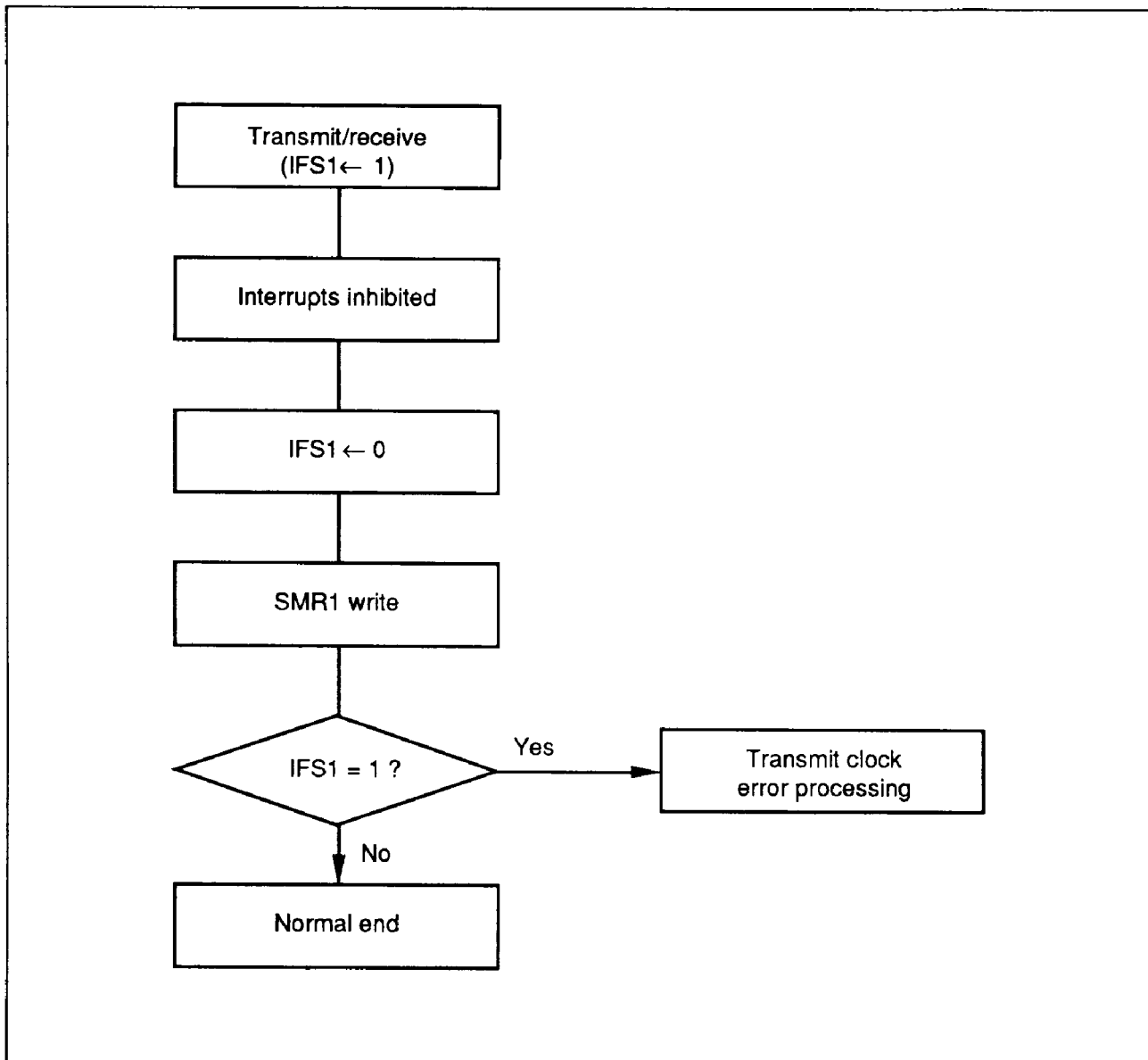

Figure 44 Transmit Clock Error Detection

**Serial Interface 2:** Used to serially transmit and receive 8-bit data. It consists of serial data register 2 (SR2), serial mode register 2 (SMR2), port mode register B (PMRB), an octal counter, and a multiplexer as shown in figure 45. The R9<sub>1</sub>/SCK<sub>2</sub> pin and the transmit clock are controlled by writing data to SMR2. The transmit clock shifts the contents of the SR2, which can be read and written to by software, and then transmission starts between two MCUs.

read instruction for SMR2, it starts counting at the falling edge of the transmit clock (SCK<sub>2</sub>), and it increments at the rising edge of the clock. When the eighth transmit clock signal is input (serial interface 2 is reset) or when serial transmission is discontinued (octal counter is reset), the serial 2 interrupt request flag (IFS2) is set.

To start serial interface 2 by an SMR2 read, execute a compare instruction on SMR2 and the accumulator. Note that 0000 is read when write-only register SMR2 is accessed.

Serial interface 2 is activated by a read instruction for SMR2. The octal counter is reset to \$0 by the

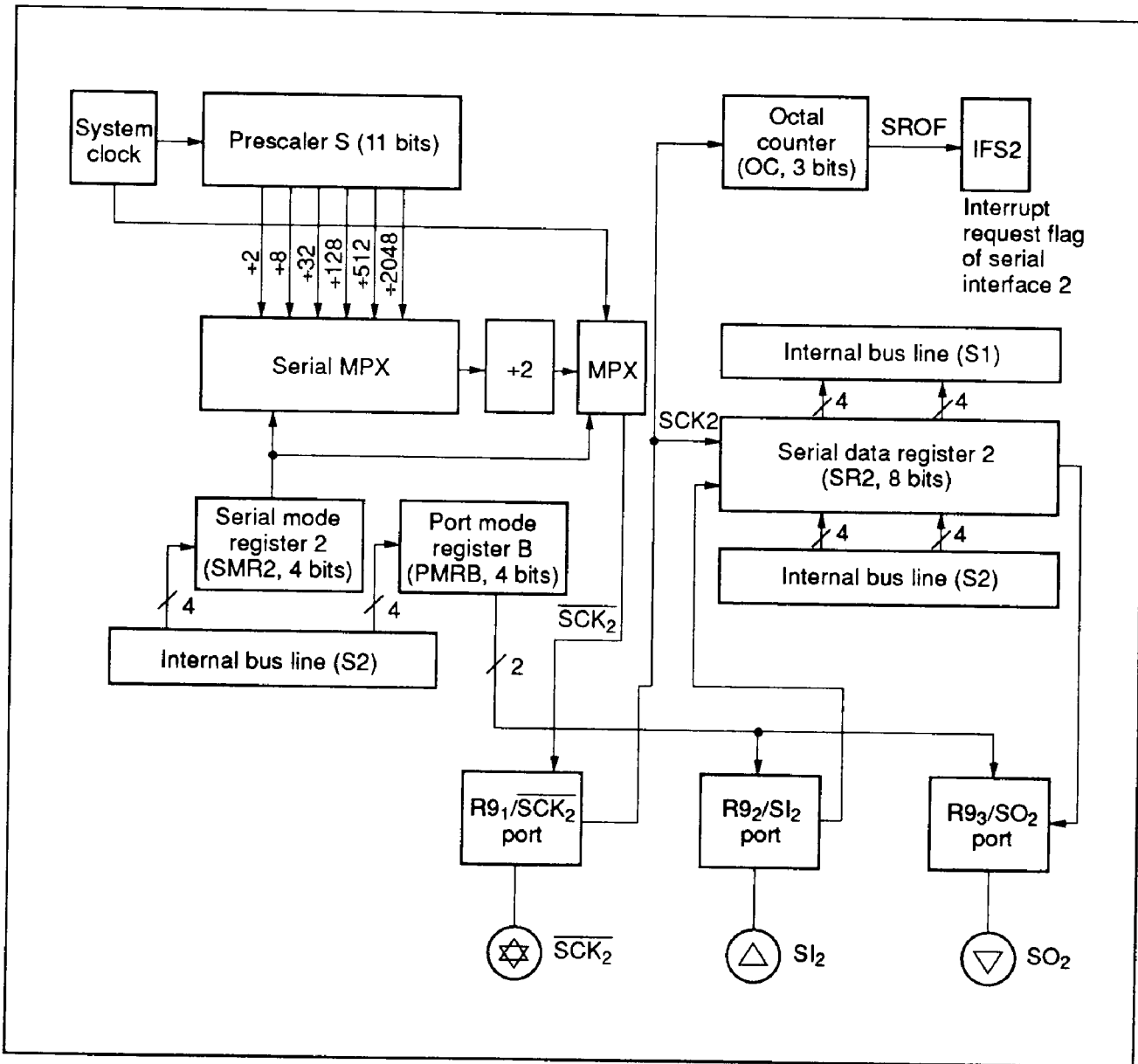

Figure 45 Serial Interface 2 Block Diagram

**Serial Mode Register 2 (SMR2: \$014):** Four-bit write-only register which controls the R9<sub>1</sub>/SCK<sub>2</sub> pin, transmit clock, and prescaler division ratio as shown in figure 46. Writing to SMR2 initializes serial interface 2.

A write signal input to SMR2 discontinues the input of the transmit clock to serial data register 2 (SR2) and the octal counter. Therefore, if a write occurs during data transmission, the octal

counter is reset to \$0 to stop transmission, and, at the same time, the serial 2 interrupt request flag (IFS2) is set.

The contents of the serial mode register are not valid until the second instruction cycle after the write instruction execution. The user must program the SMR2 read instruction to be executed after this instruction cycle. The serial mode register is initialized to \$0 by MCU reset.

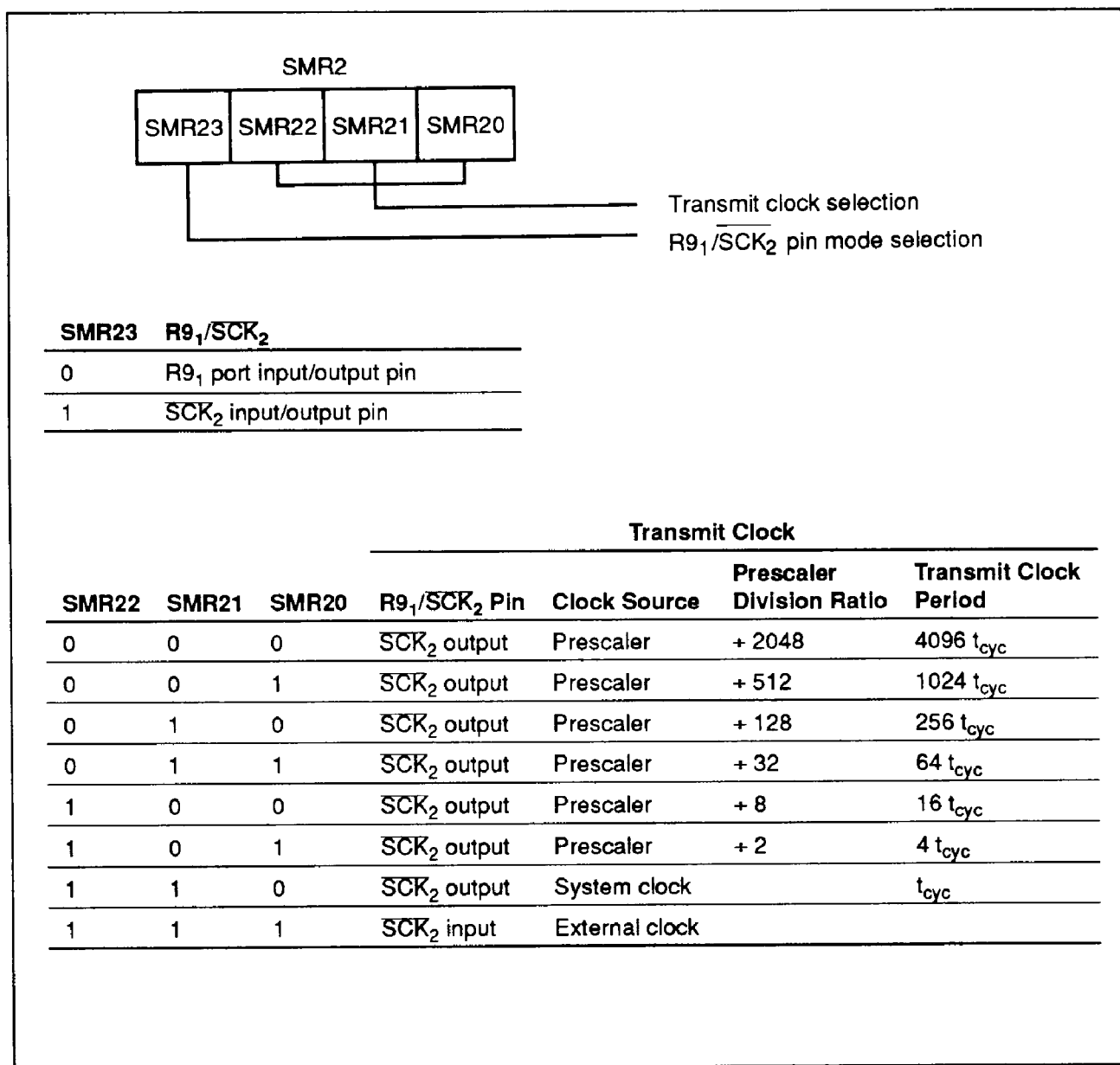

Figure 46 Serial Mode Register 2

**Serial Data Register 2 (SR2L: \$015, SR2U: \$016):** Eight-bit read/write register separated into lower and upper digits located at sequential addresses. Data in this register is output from the SO<sub>2</sub> pin LSB first, synchronously with the falling edge of the transmit clock, and data is input, LSB first through the SI<sub>2</sub> pin at the rising edge of the transmit clock. Input/output timing is shown in figure 47.

transmission. If data is read or written during transmission, it cannot be guaranteed.

**Selecting and Changing Operating Modes:** Table 31 lists the operating modes of serial interface 2. The combination of port mode register B (PMRB) and serial mode register 2 (SMR2) must be specified as shown in the table. To change the operating mode of serial interface 2, internally initialize serial interface 2 by writing to SMR2.

Data cannot be read or written during serial data

**Table 31 Operating Modes of Serial Interface 2**

SMR2 Bit 3	PMRB		Operating Mode
	Bit 1	Bit 0	
1	0	0	Continuous clock output mode
1	0	1	Transmit mode
1	1	0	Receive mode
1	1	1	Transmit/receive mode

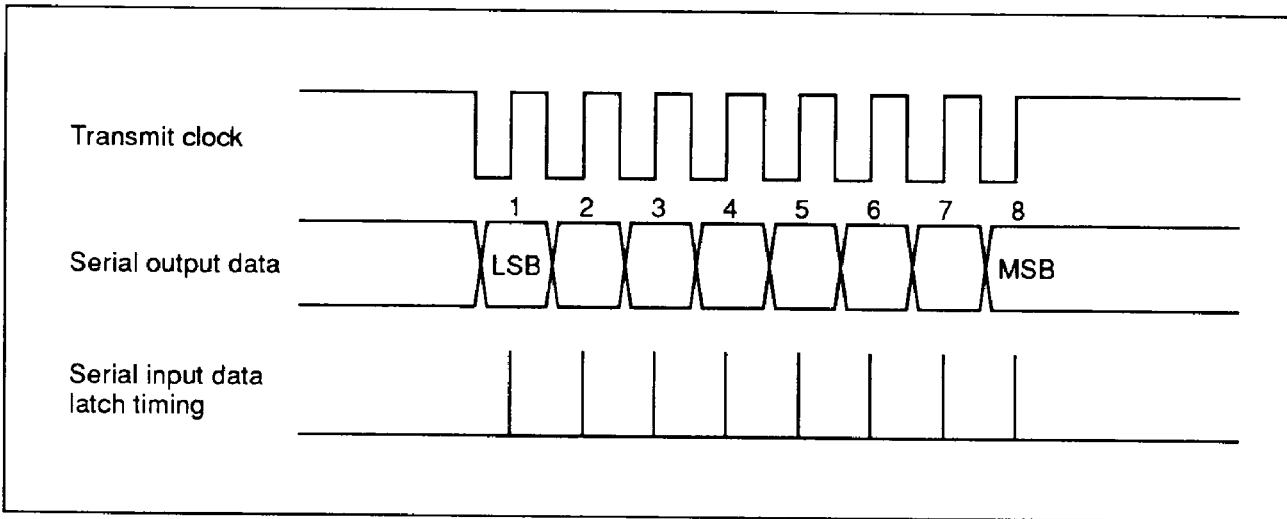

**Figure 47 Serial Interface 2 Timing**

**Serial Interface 2 Operation:** Three operating modes are provided for serial interface 2; transitions between them are shown in figure 48.

In SMR2 read wait state, serial interface 2 is initialized and the transmit clock is ignored. If an SMR2 read is executed, serial interface 2 enters transmit clock wait state.

In transmit clock wait state, input of the transmit clock increments the octal counter, shifts serial data register 2 (SR2), and starts serial transmission. However, note that if continuous clock output mode is selected, the transmit clock is continuously output, but data is not transmitted.

During transmission, the input of 8 clocks or a SMR2 read sets the octal counter to 000, and serial interface 2 enters transmit clock wait state. If an external transmit clock is further applied, serial interface 2 enters transfer state. If the internal clock has been selected, the serial 2 interrupt flag is set, serial interface 2 enters SMR2 read wait state, and serial transmission is stopped after the eighth clock is output.

If port mode register B (PMRB) is written to in transmit clock wait state or during transmission, SMR2 must be written to, to initialize serial interface 2, after which serial interface 2 enters SMR2 read (serial start) wait state.

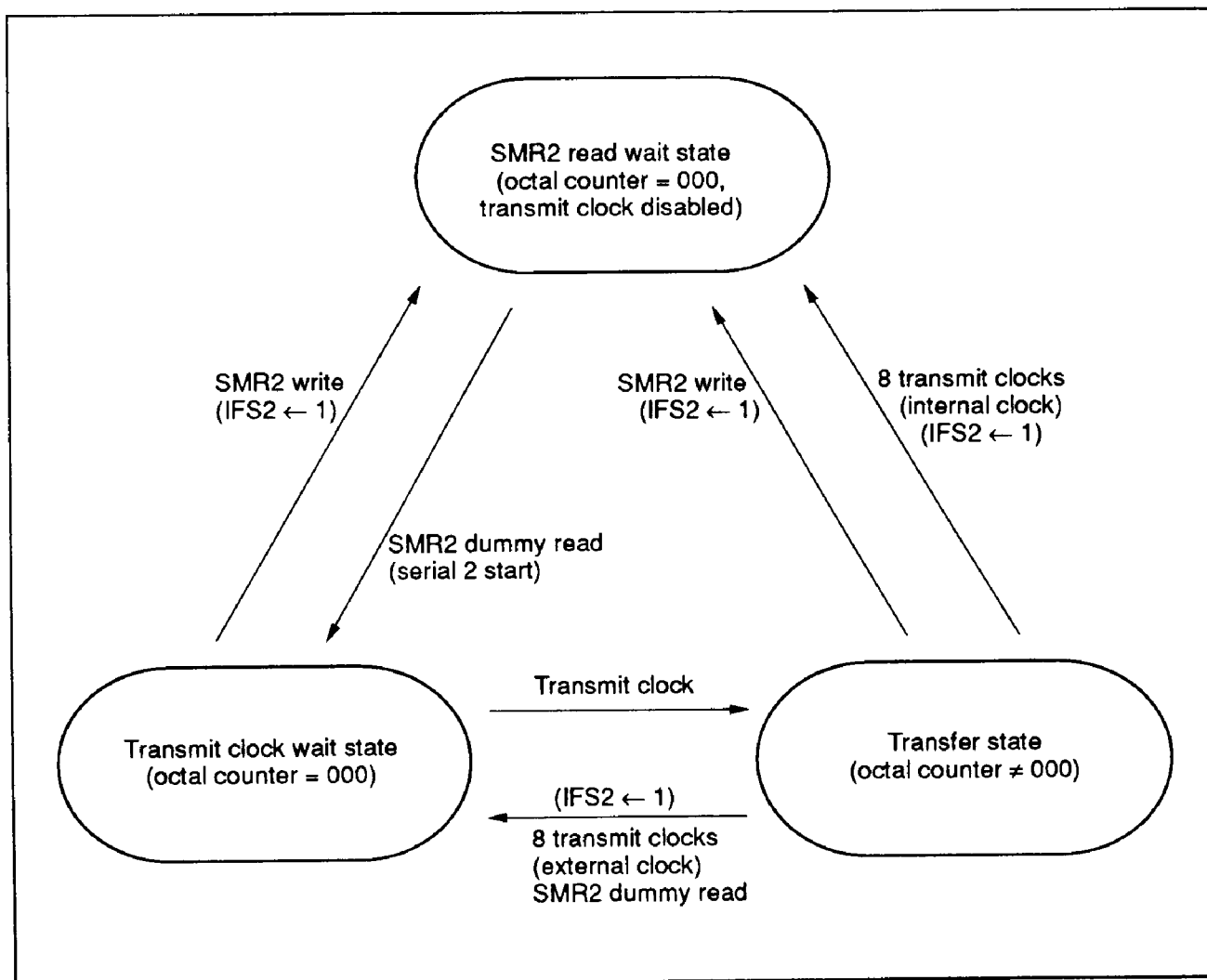

Figure 48 Serial Interface 2 Mode Transitions

**Transmit Clock Error Detection:** Serial interface 2 will malfunction if a spurious pulse caused by external noise conflicts with a normal transmit clock. Such errors can be detected as shown in figure 49.

If more than eight transmit clocks are input in transmit clock wait state, serial interface 2's state

changes to transfer state, transmit clock wait state, then back to transfer state.

When serial interface 2 is set to SMR2 read wait state by writing data to SMR2 at transfer state after the serial interface 2 interrupt request flag (IFS2) has been reset, the flag is set again.

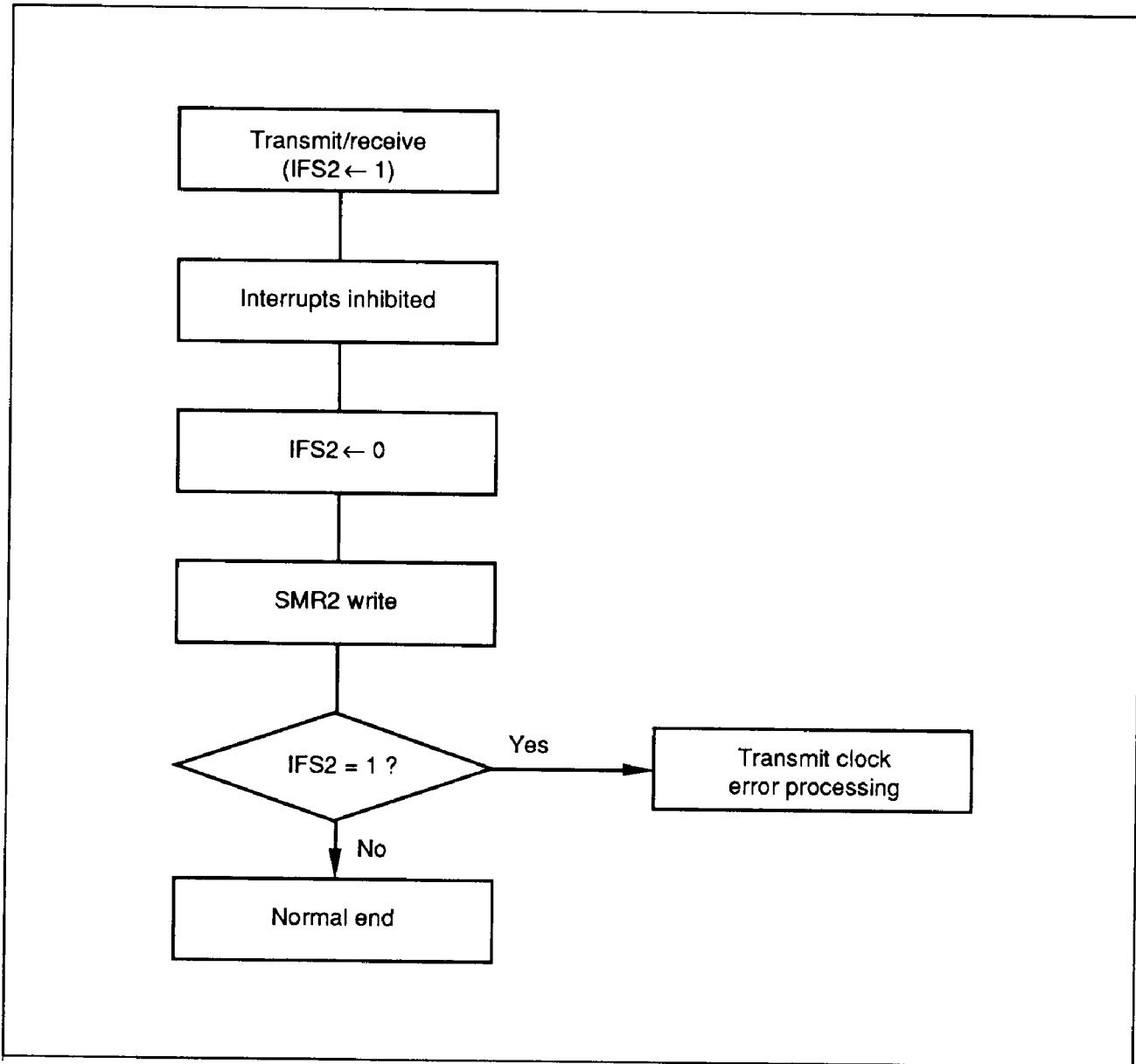

**Figure 49** Transmit Clock Error Detection



### A/D Converter

The MCU has an 8-bit A/D converter of serial comparison type. It has eight input channels. The block diagram is shown in figure 50.

**A/D Control Register (ADCR: \$01B):** Selects the analog input pin or digital input port and selects one of eight analog input channels. The eight input pins (RC<sub>0</sub>/AN<sub>0</sub>–RC<sub>3</sub>/AN<sub>3</sub>, RD<sub>0</sub>/AN<sub>4</sub>–RD<sub>3</sub>/AN<sub>7</sub>) must not include analog input mode pins and port input mode pins at the same time; all the pins must be set to the same mode. When selecting analog input mode for these pins, select without pull-up MOS option for the pins.

**A/D Status Register (ADSR: \$01F):** A/D conversion is started by setting 1 to the A/D start flag.

At conversion completion, the converted data is set to the A/D data register and the A/D start flag is reset.

**A/D Mode Register (AMR: \$01C):** Two-bit write-only register which selects the A/D conversion speed.

**A/D Data Register (ADRL: \$01D, ADRU: \$01E):** Eight-bit read-only register separated into lower and upper digits. Eight-bit A/D converted data is set to the register at conversion completion, and is held until the next conversion starts. Data read during conversion is invalid. The register cannot be cleared by MCU reset.

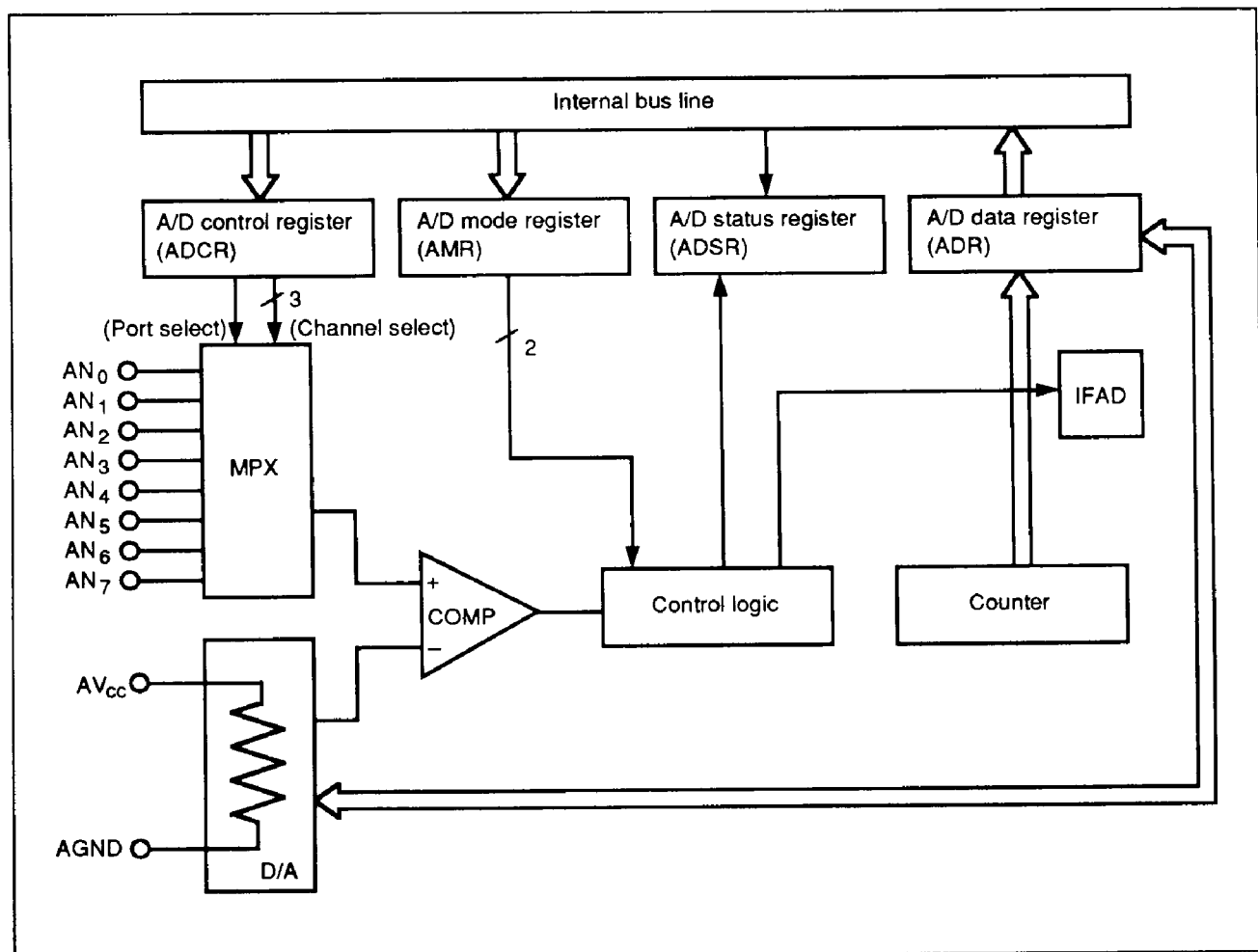

Figure 50 Block Diagram of A/D Converter

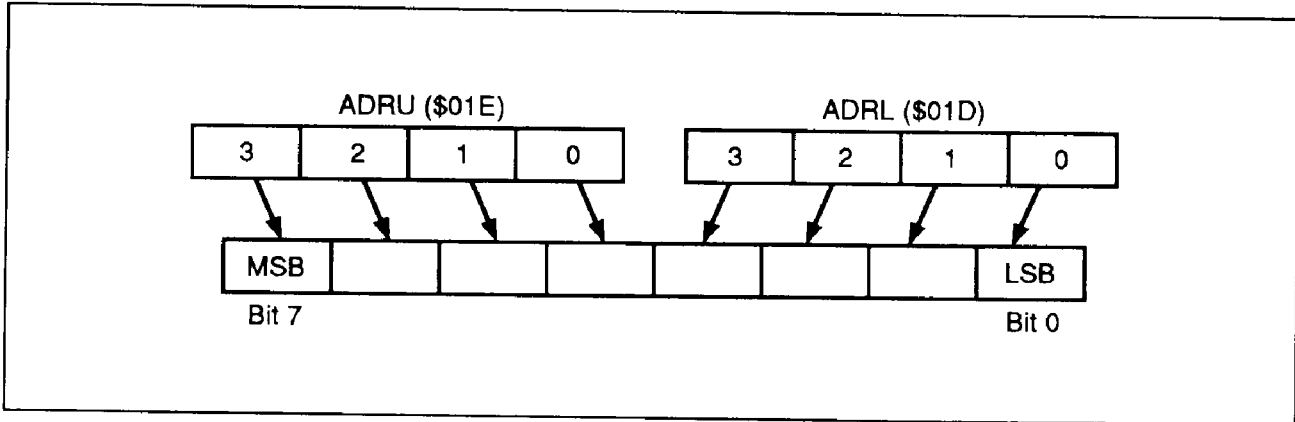

Figure 51 A/D Data Register

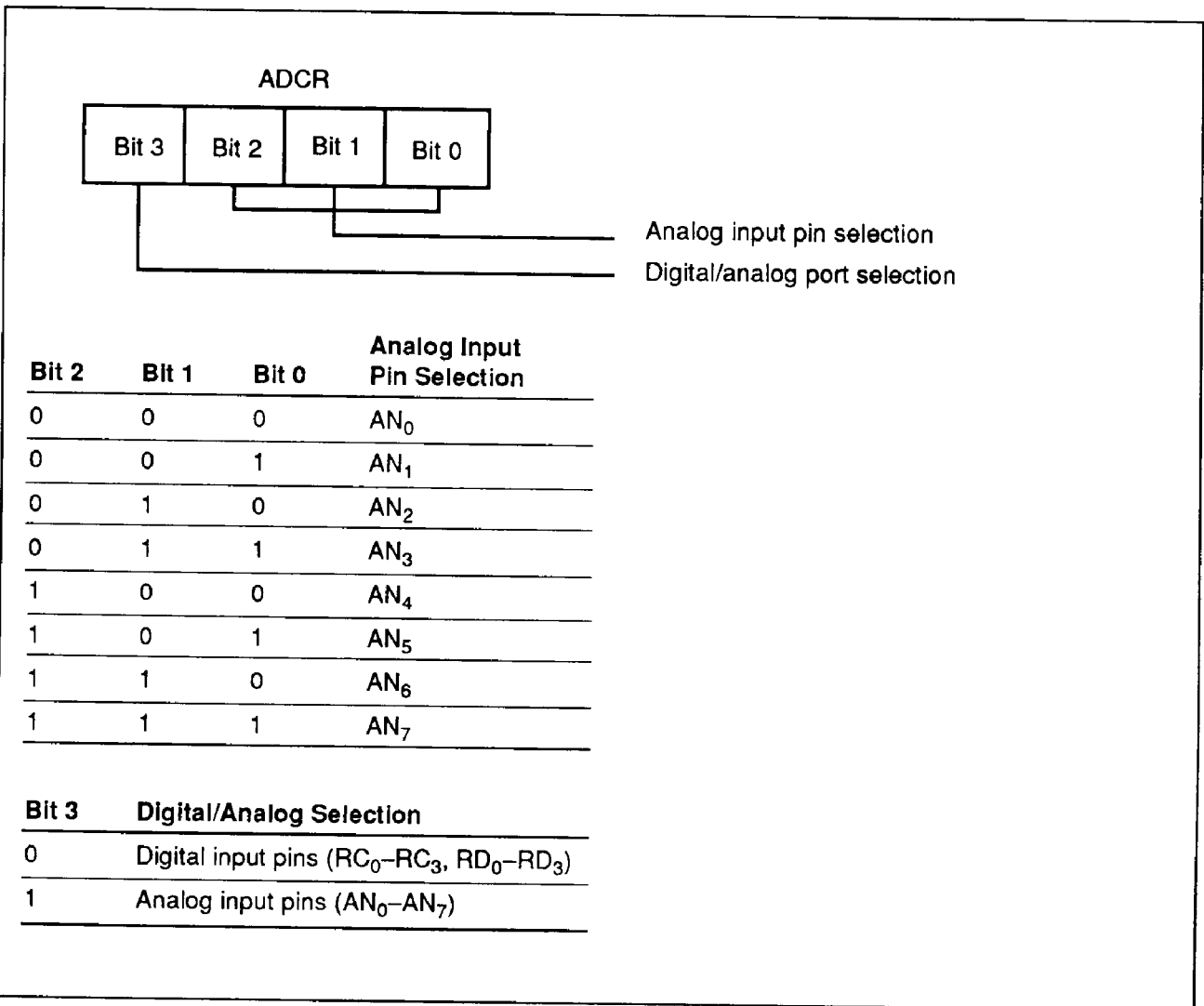
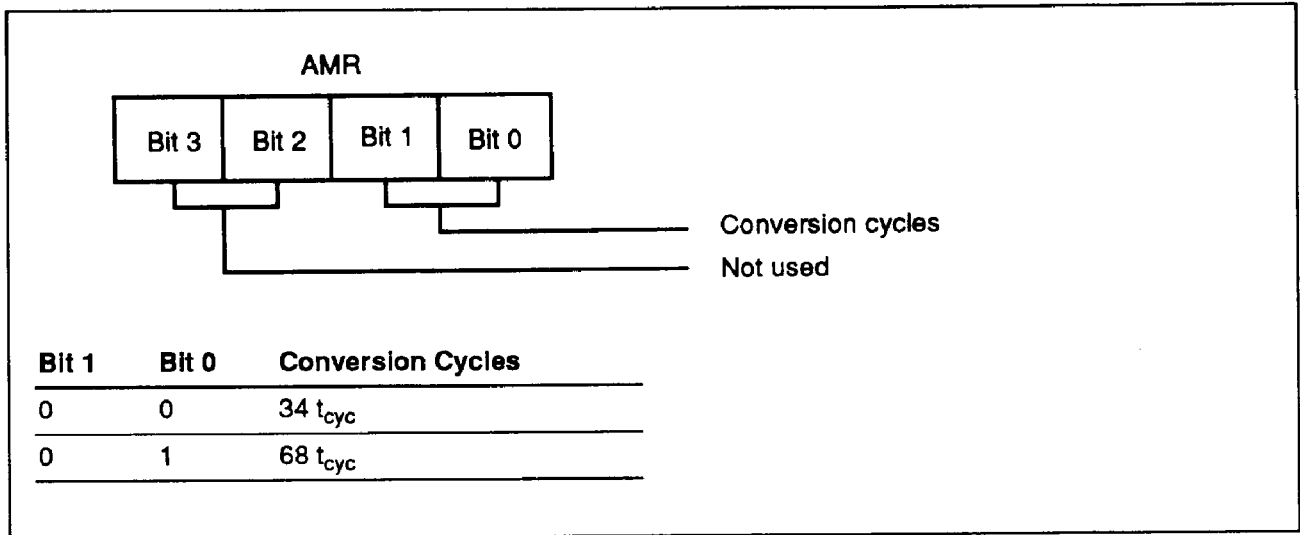
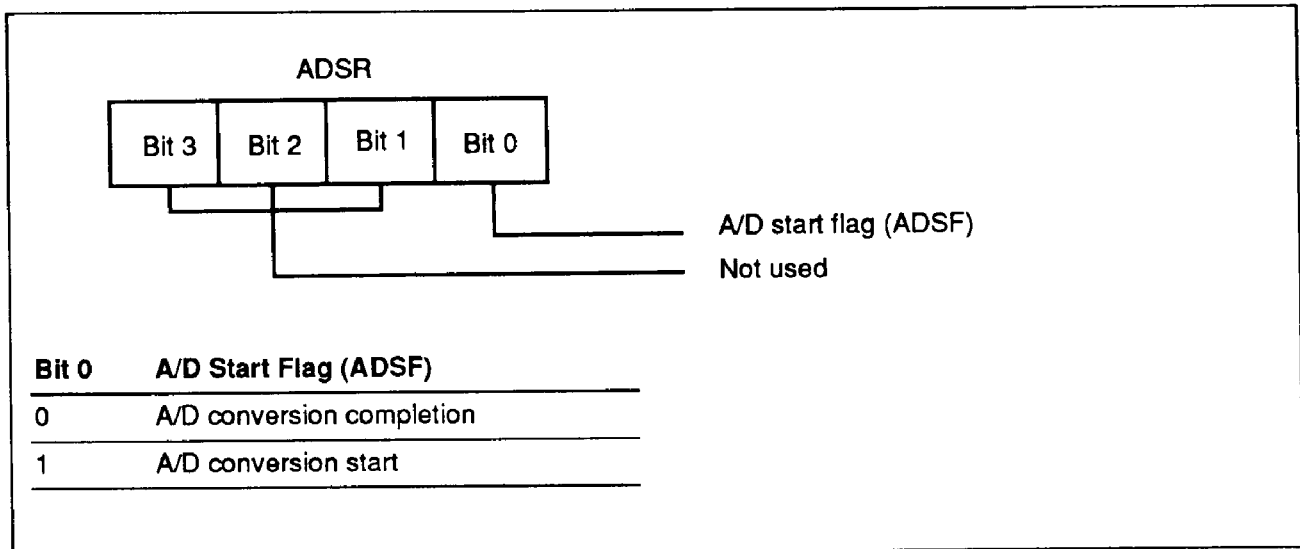

Figure 52 A/D Control Register



**Figure 53 A/D Mode Register**



**Figure 54 A/D Status Register**

## Comparator

The block diagram of the comparator is shown in figure 55. The comparator compares input voltage with the reference voltage. Internal voltage or external input voltage can be selected as the reference. Internal reference voltage is selected from seven levels. When bits 0, 1, and 2 of the compare control register are 0, external reference voltage is input.

The LAR instruction executes a voltage comparison. When the COMP input voltage is higher than

the reference voltage, data 0 is read from port R6<sub>0</sub>.

The power supply for the comparator is the digital V<sub>CC</sub> and GND. When using the comparator, select with pull-up MOS option for pins R6<sub>0</sub> and R6<sub>1</sub>.

**Compare Control Register (CCR: \$03E):** Four-bit write-only register which enables comparator operation and selects internal reference voltage sources.

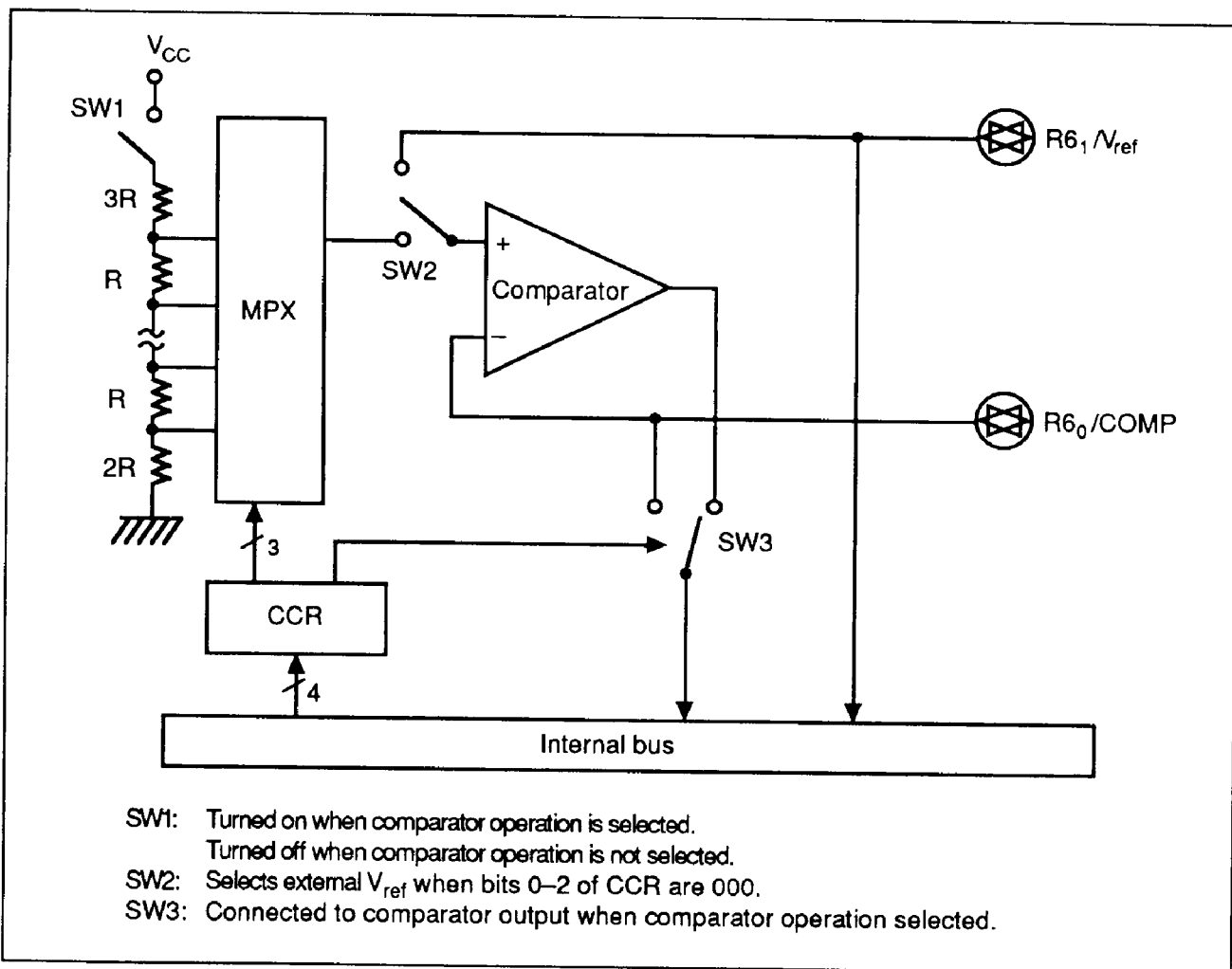

Figure 55 Block Diagram of Comparator

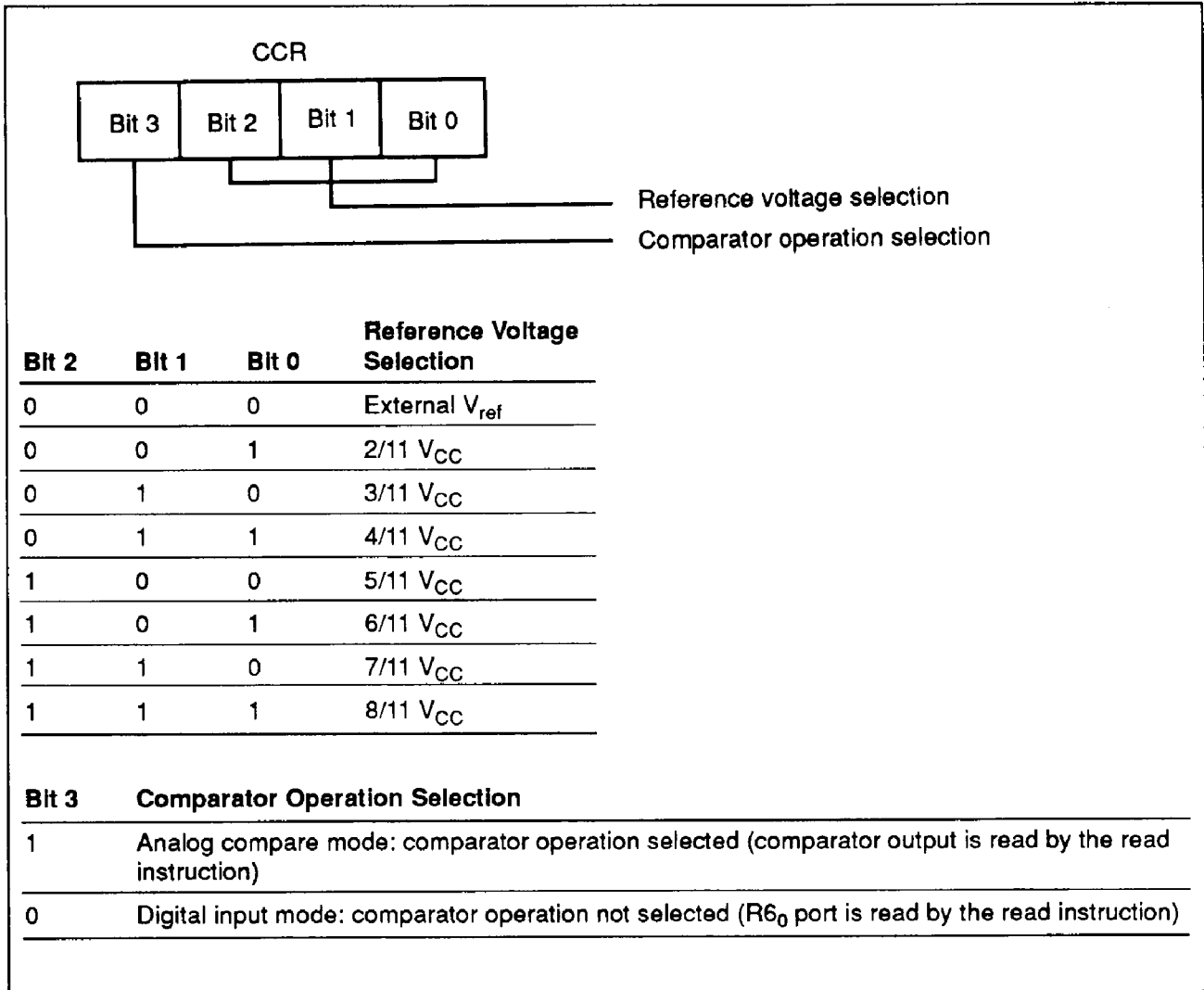

Figure 56 Compare Control Register

# HD404719/HD404439/HD4074719

## Programmable ROM (HD4074719)

The HD4074719 is a ZTAT™ microcomputer with built-in PROM that can be programmed in PROM mode.

### PROM Mode Pin Description

Pin Number		MCU Mode		PROM Mode		Pin Number		MCU Mode		PROM Mode	
FP-80B	FP-80A	Pin Name	I/O	Pin Name	I/O	FP-80B	FP-80A	Pin Name	I/O	Pin Name	I/O
1	79	RD <sub>1</sub> /AN <sub>5</sub>	I			31	29	R0 <sub>2</sub>	I/O	A <sub>3</sub>	I
2	80	RD <sub>2</sub> /AN <sub>6</sub>	I			32	30	R0 <sub>3</sub>	I/O	A <sub>4</sub>	I
3	1	RD <sub>3</sub> /AN <sub>7</sub>	I			33	31	R1 <sub>0</sub>	I/O	A <sub>5</sub>	I
4	2	AGND		GND		34	32	R1 <sub>1</sub>	I/O	A <sub>6</sub>	I
5	3	RESET	I	RESET	I	35	33	R1 <sub>2</sub>	I/O	A <sub>7</sub>	I
6	4	OSC <sub>1</sub>	I	GND		36	34	R1 <sub>3</sub>	I/O	A <sub>8</sub>	I
7	5	OSC <sub>2</sub>	O			37	35	R2 <sub>0</sub>	I/O	A <sub>0</sub>	I
8	6	GND		GND		38	36	R2 <sub>1</sub>	I/O	A <sub>10</sub>	I
9	7	CL <sub>1</sub>	I	GND		39	37	R2 <sub>2</sub>	I/O	A <sub>11</sub>	I
10	8	CL <sub>2</sub>	O			40	38	R2 <sub>3</sub>	I/O	A <sub>12</sub>	I
11	9	TEST	I	TEST	I	41	39	R3 <sub>0</sub>	I/O	A <sub>13</sub>	I
12	10	V <sub>CC</sub>		V <sub>CC</sub>		42	40	R3 <sub>1</sub>	I/O	A <sub>14</sub>	I
13	11	D <sub>0</sub>	I/O			43	41	R3 <sub>2</sub>	I/O		
14	12	D <sub>1</sub>	I/O			44	42	R3 <sub>3</sub>	I/O		
15	13	D <sub>2</sub>	I/O			45	43	R4 <sub>0</sub>	I/O		
16	14	D <sub>3</sub>	I/O			46	44	R4 <sub>1</sub>	I/O		
17	15	D <sub>4</sub>	I/O			47	45	R4 <sub>2</sub>	I/O		
18	16	D <sub>5</sub>	I/O			48	46	R4 <sub>3</sub>	I/O		
19	17	D <sub>6</sub>	I/O			49	47	R5 <sub>0</sub>	I		
20	18	D <sub>7</sub>	I/O			50	48	R5 <sub>1</sub>	I	V <sub>CC</sub>	
21	19	D <sub>8</sub>	I/O			51	49	R5 <sub>2</sub>	I	V <sub>PP</sub>	
22	20	D <sub>9</sub>	I/O			52	50	R5 <sub>3</sub>	I	A <sub>9</sub>	I
23	21	D <sub>10</sub>	I/O			53	51	R6 <sub>0</sub> /COMP	I/O	CE	I
24	22	D <sub>11</sub>	I/O			54	52	R6 <sub>1</sub> /V <sub>ref</sub>	I/O	OE	I
25	23	D <sub>12</sub>	I/O			55	53	R6 <sub>2</sub> /TOE <sub>1</sub>	I/O	V <sub>CC</sub>	
26	24	D <sub>13</sub>	I/O			56	54	R6 <sub>3</sub> /TOE <sub>2</sub>	I/O	V <sub>CC</sub>	
27	25	D <sub>14</sub>	I/O			57	55	R7 <sub>0</sub> /INT <sub>0</sub>	I/O	O <sub>0</sub>	I/O
28	26	D <sub>15</sub>	I/O			58	56	R7 <sub>1</sub> /INT <sub>1</sub>	I/O	O <sub>1</sub>	I/O
29	27	R0 <sub>0</sub>	I/O	A <sub>1</sub>	I	59	57	R7 <sub>2</sub> /INT <sub>2</sub>	I/O	O <sub>2</sub>	I/O
30	28	R0 <sub>1</sub>	I/O	A <sub>2</sub>	I	60	58	R7 <sub>3</sub> /INT <sub>3</sub>	I/O	O <sub>3</sub>	I/O

- Notes: 1. I/O: Input/output pin, I: Input pin, O: Output pin  
 2. O<sub>0</sub>–O<sub>4</sub> each have 2 pins; connect each pair together for use.

# HD404719/HD404439/HD4074719

Pin Number		MCU Mode		PROM Mode		Pin Number		MCU Mode		PROM Mode	
FP-80B	FP-80A	Pin Name	I/O	Pin Name	I/O	FP-80B	FP-80A	Pin Name	I/O	Pin Name	I/O
61	59	R8 <sub>0</sub> /INT <sub>4</sub>	I/O	O <sub>4</sub>	I/O	71	69	RA <sub>2</sub> /TOG	I/O	O <sub>7</sub>	I/O
62	60	R8 <sub>1</sub> /INT <sub>5</sub>	I/O	O <sub>4</sub>	I/O	72	70	RA <sub>3</sub> /BUZZ	I/O		
63	61	R8 <sub>2</sub> /SO <sub>1</sub>	I/O	O <sub>3</sub>	I/O	73	71	RB <sub>0</sub> /TOC	I/O	M <sub>0</sub>	I
64	62	R8 <sub>3</sub> /SI <sub>1</sub>	I/O	O <sub>2</sub>	I/O	74	72	RB <sub>1</sub> /TOD	I/O	M <sub>1</sub>	I
65	63	R9 <sub>0</sub> /SCK <sub>1</sub>	I/O	O <sub>1</sub>	I/O	75	73	AV <sub>CC</sub>		V <sub>CC</sub>	
66	64	R9 <sub>1</sub> /SCK <sub>2</sub>	I/O	O <sub>0</sub>	I/O	76	74	RC <sub>0</sub> /AN <sub>0</sub>	I		
67	65	R9 <sub>2</sub> /SI <sub>2</sub>	I/O			77	75	RC <sub>1</sub> /AN <sub>1</sub>	I		
68	66	R9 <sub>3</sub> /SO <sub>2</sub>	I/O			78	76	RC <sub>2</sub> /AN <sub>2</sub>	I		
69	67	RA <sub>0</sub> /ICT <sub>0</sub>	I/O	O <sub>5</sub>	I/O	79	77	RC <sub>3</sub> /AN <sub>3</sub>	I		
70	68	RA <sub>1</sub> /ICT <sub>1</sub>	I/O	O <sub>6</sub>	I/O	80	78	RD <sub>0</sub> /AN <sub>4</sub>	I		

- Notes:
1. I/O: Input/output pin, I: Input pin, O: Output pin
  2. O<sub>0</sub>–O<sub>4</sub> each have 2 pins; connect each pair together for use.

**PROM Mode Pin Functions**

**V<sub>PP</sub>**: Applies the programming voltage (12.5 V ± 0.3 V) to the built-in PROM.

**$\overline{CE}$** : Inputs a control signal to enable PROM programming and verification.

**$\overline{OE}$** : Inputs a data output control signal for verification.

**A<sub>0</sub>-A<sub>14</sub>**: Address input pins of the built-in PROM.

**O<sub>0</sub>-O<sub>7</sub>**: Data bus input pins of the built-in PROM.

**$\overline{M}_0, \overline{M}_1$** : Used to set PROM mode. The MCU is set to the PROM mode by pulling  $\overline{M}_0, \overline{M}_1$ , and  $\overline{TEST}$  low, and RESET high.

The pin arrangement in PROM mode is shown in figure 57.

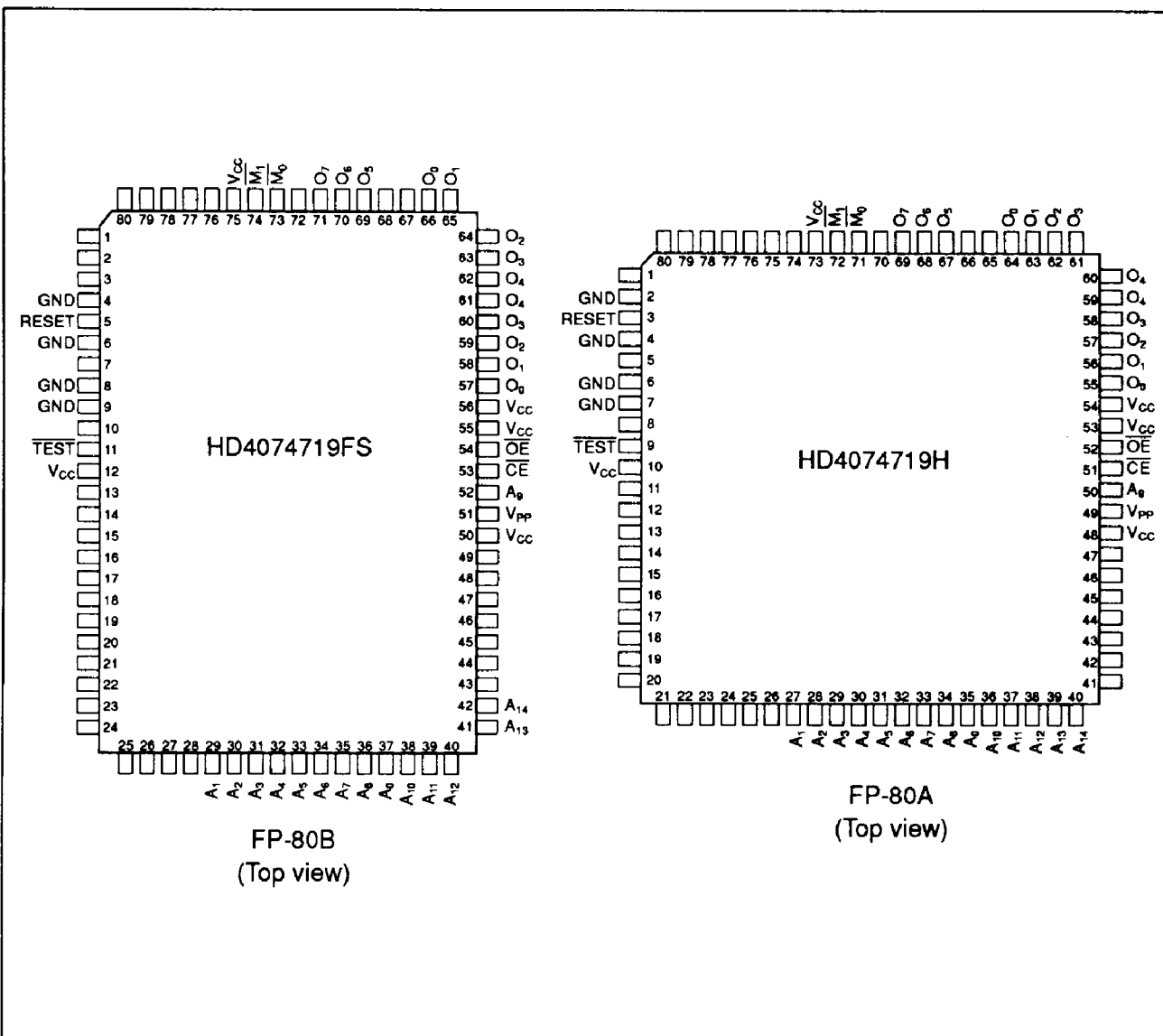

**Figure 57 Pin Arrangement in PROM Mode**



## Programming the Built-In PROM

The MCU's built-in PROM is programmed in PROM mode which is set by pulling  $\overline{\text{TEST}}$ ,  $\overline{\text{M}}_0$ , and  $\overline{\text{M}}_1$  low, and RESET high as shown in figure 58. In PROM mode, the MCU stops, and the PROM is programmed in the same way as a 27256 EPROM using a standard PROM programmer and an 80-to-28-pin socket adapter. Recommended PROM programmers and socket adapters are listed in table 33.

Since an HMCS400-series instruction is ten bits long, the MCU has a built-in conversion circuit for a general-purpose PROM programmer. This circuit splits each instruction into lower 5 bits and upper 5 bits that are read from or written to two consecutive addresses, as shown in figure 59. This means that if, for example, 16 Kwords of built-in PROM are to be programmed by a general-purpose PROM programmer, a 32-Kbyte address space (\$0000–\$7FFF) must be specified.

**Programming and Verification:** The built-in PROM of the MCU can be programmed at high-speed programming sequence without voltage stress or damage to data reliability.

Programming and verification modes are selected as shown in table 32, the memory map in PROM mode is shown in figure 59, the programming flowchart is shown in figure 60, and a timing chart

of PROM programming and verification is shown in figure 61.

For details of PROM programming, refer to the Notes on PROM Programming section.

### Warnings

1. Always specify addresses \$0000 to \$7FFF when programming with a PROM programmer. If address \$8000 or higher is accessed, the PROM may not be programmed or verified correctly. Set all data in unused addresses to \$FF.

Note that the plastic-package version cannot be erased and reprogrammed.

2. Make sure that the PROM programmer, socket adapter, and LSI are inserted correctly (in the correct direction), otherwise overcurrents may damage the LSI. Before starting programming, make sure that the LSI is firmly fixed in the socket adapter and the socket adapter is firmly fixed onto the programmer.
3. PROM programmers have two voltage settings ( $V_{PP}$ ): 12.5 V and 21 V. Remember that ZTAT™ devices require a  $V_{PP}$  of 12.5 V—the 21 V setting will damage them. 12.5 V is the Intel's 27256 setting.

Table 32 PROM Mode Selection

Mode	PIn			
	$\overline{\text{CE}}$	$\overline{\text{OE}}$	$V_{PP}$	$\text{O}_0\text{--}\text{O}_7$
Programming	Low	High	$V_{PP}$	Data input
Verification	High	Low	$V_{PP}$	Data output
Programming inhibited	High	High	$V_{PP}$	High impedance

**Table 33 Recommended PROM Programmings and Socket Adapters**

PROM Programmer		Socket Adapter		
Manufacturer	Model Name	Package	Manufacturer	Model Name
DATA I/O Corp.	29B	FP-80A	Hitachi	HS471ESH01H
	Unisite	FP-80B	Hitachi	HS471ESF01H
AVAL Data Corp.	PKW-1000	FP-80A	Hitachi	HS471ESH01H
	PKW-3100	FP-80B	Hitachi	HS471ESF01H

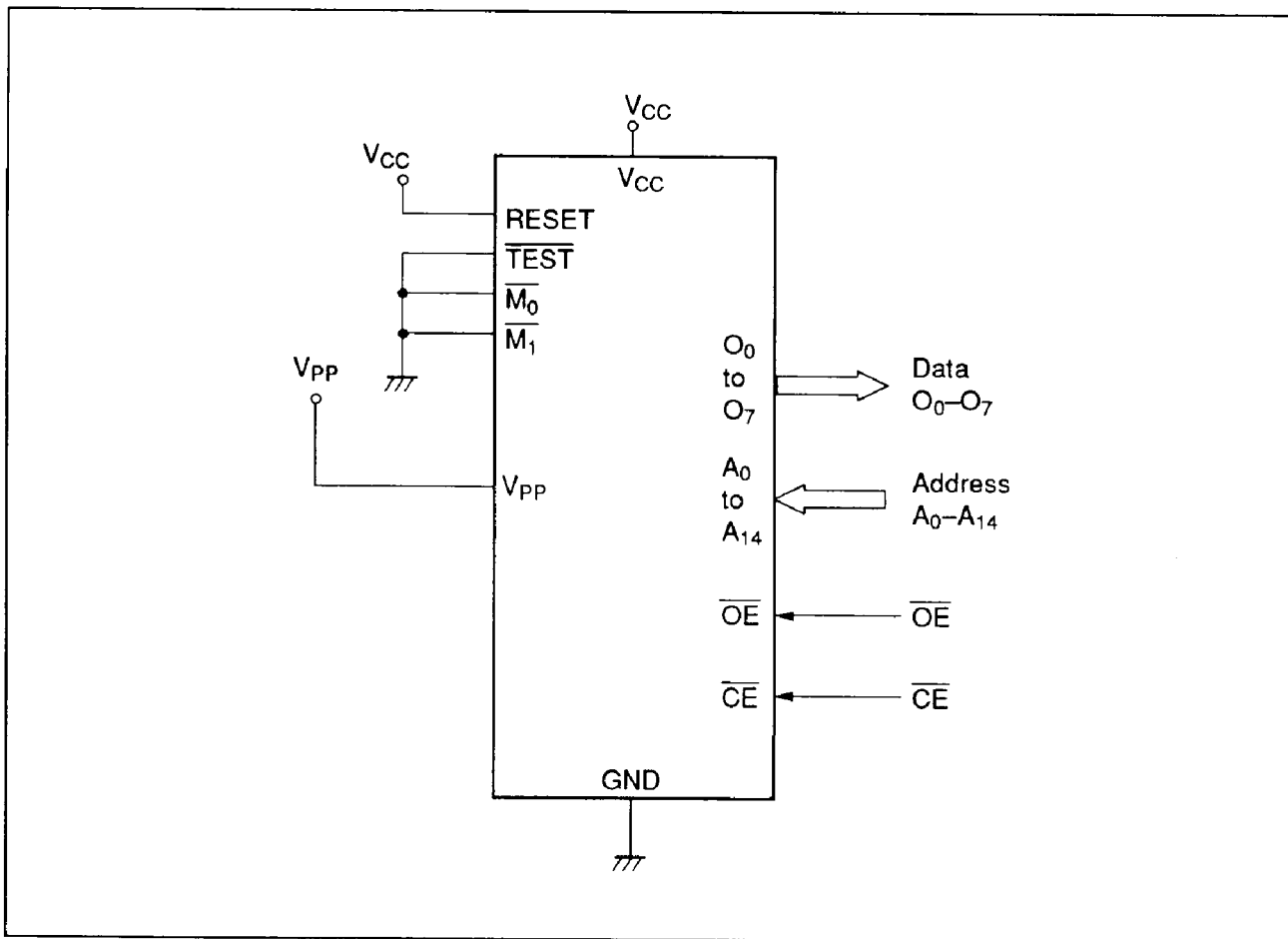

**Figure 58 Connections for PROM Mode**

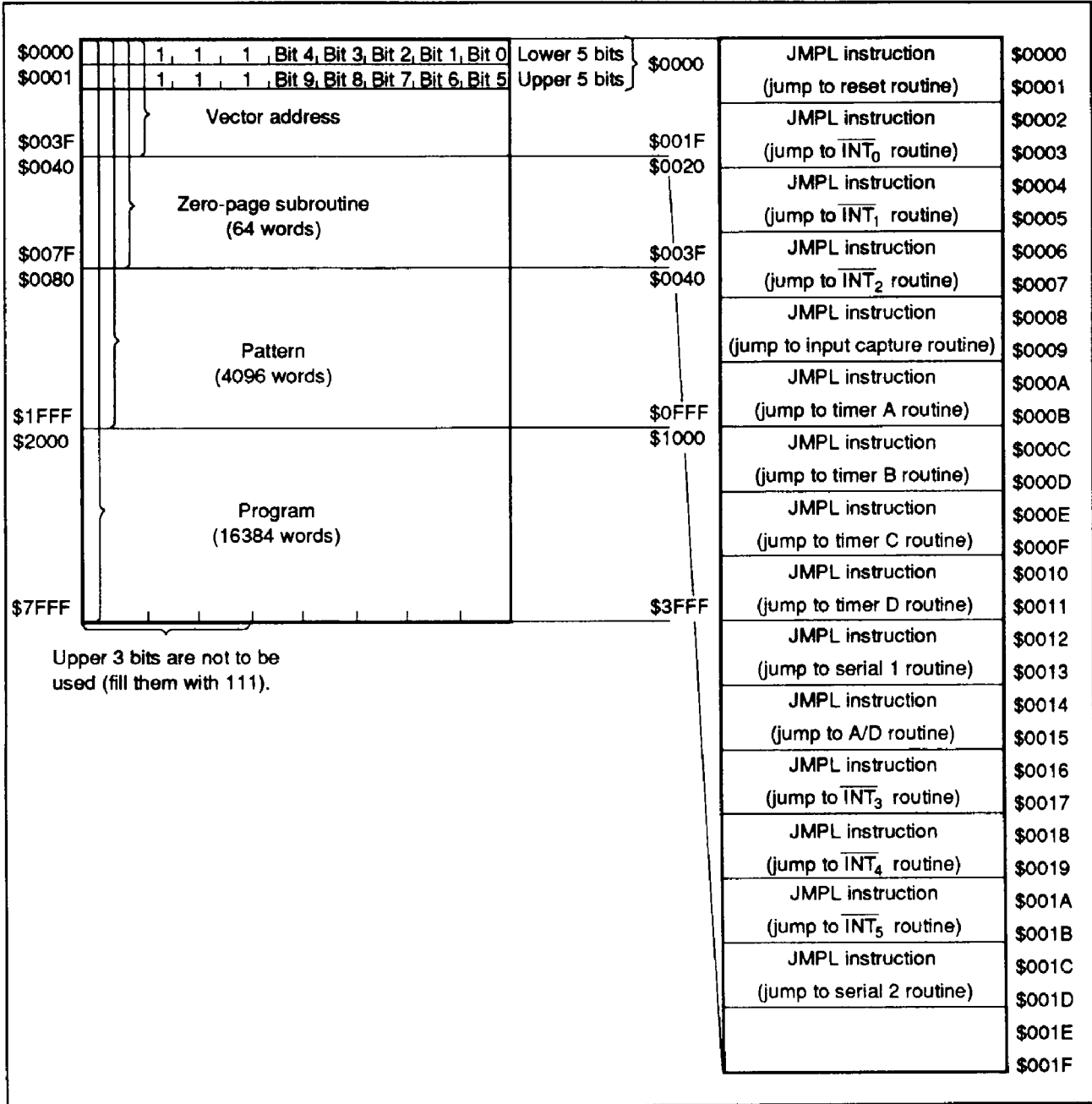

Figure 59 Memory Map in PROM Mode

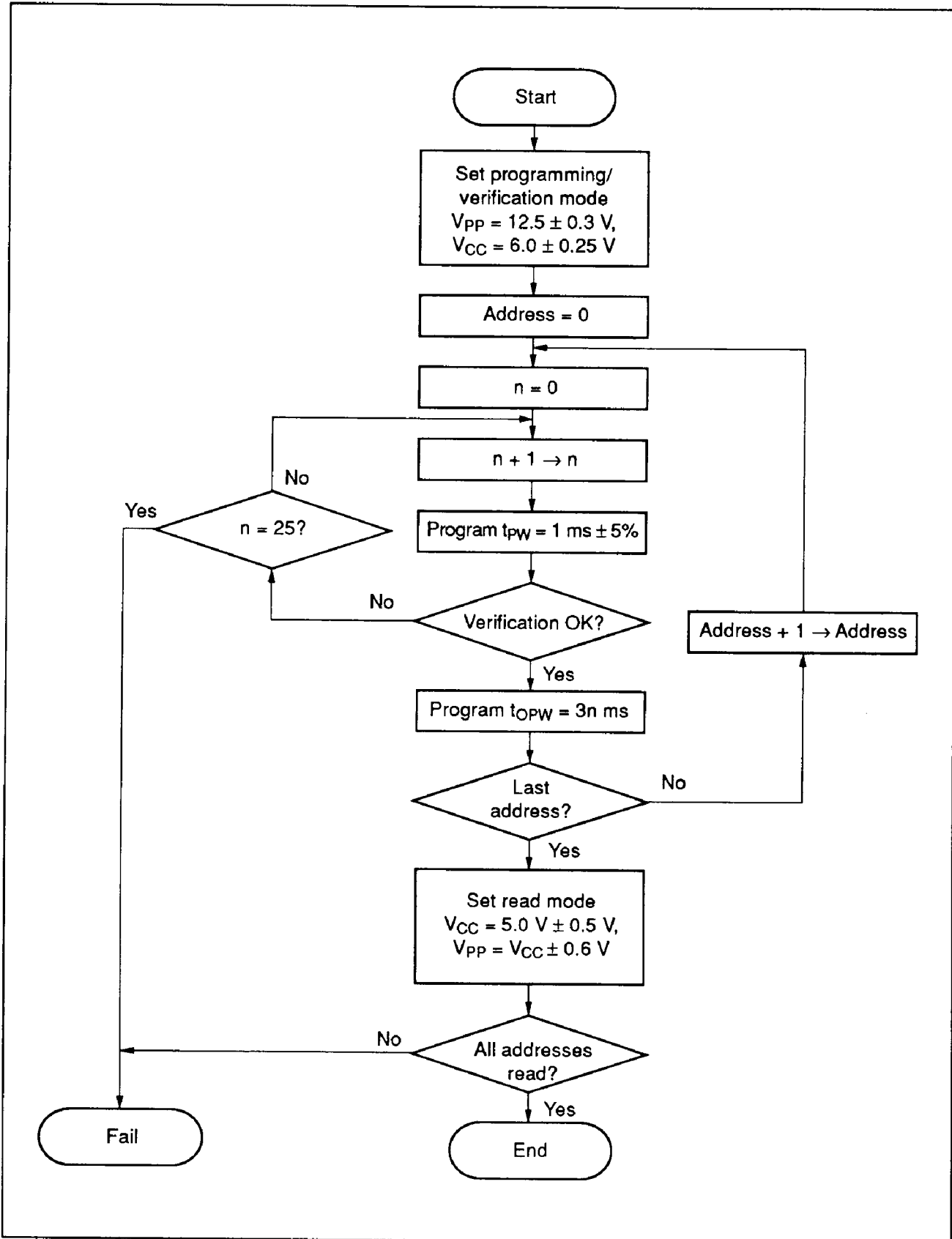

Figure 60 High-Speed Programming Flowchart

**Programming and Verification Electrical Characteristics**

**DC Characteristics** ( $V_{CC} = 6\text{ V} \pm 0.25\text{ V}$ ,  $V_{PP} = 12.5\text{ V} \pm 0.3\text{ V}$ ,  $GND = 0.0\text{ V}$ ,  $T_a = 25^\circ\text{C} \pm 5^\circ\text{C}$ , unless otherwise specified)

Item	Symbol	Pin(s)	Min	Typ	Max	Unit	Test Condition
Input high voltage	$V_{IH}$	$O_0-O_7, A_0-A_{14}, \overline{OE}, \overline{CE}$	2.2	—	$V_{CC} + 0.3$	V	
Input low voltage	$V_{IL}$	$O_0-O_7, A_0-A_{14}, \overline{OE}, \overline{CE}$	-0.3	—	0.8	V	
Output high voltage	$V_{OH}$	$O_0-O_7$	2.4	—	—	V	$I_{OH} = -200\ \mu\text{A}$
Output low voltage	$V_{OL}$	$O_0-O_7$	—	—	0.4	V	$I_{OL} = 1.6\text{ mA}$
Input leakage current	$ I_{IL} $	$O_0-O_7, A_0-A_{14}, \overline{OE}, \overline{CE}$	—	—	2	$\mu\text{A}$	$V_{in} = 5.25\text{ V} / 0.5\text{ V}$
$V_{CC}$ current	$I_{CC}$		—	—	30	mA	
$V_{PP}$ current	$I_{PP}$		—	—	40	mA	

**AC Characteristics** ( $V_{CC} = 6\text{ V} \pm 0.25\text{ V}$ ,  $V_{PP} = 12.5\text{ V} \pm 0.3\text{ V}$ ,  $GND = 0.0\text{ V}$ ,  $T_a = 25^\circ\text{C} \pm 5^\circ\text{C}$ , unless otherwise specified)

Item	Symbol	Min	Typ	Max	Unit	Test Condition
Address setup time	$t_{AS}$	2	—	—	$\mu\text{s}$	Refer to figure 61
$\overline{OE}$ setup time	$t_{OES}$	2	—	—	$\mu\text{s}$	
Data setup time	$t_{DS}$	2	—	—	$\mu\text{s}$	
Address hold time	$t_{AH}$	0	—	—	$\mu\text{s}$	
Data hold time	$t_{DH}$	2	—	—	$\mu\text{s}$	
Output disable delay time	$t_{DF}^{\text{Note}}$	—	—	130	ns	
$V_{PP}$ setup time	$t_{VPS}$	2	—	—	$\mu\text{s}$	
Program pulse width	$t_{PW}$	0.95	1.0	1.05	ms	
$\overline{CE}$ pulse width during overprogramming	$t_{OPW}$	2.85	—	78.75	ms	
$V_{CC}$ setup time	$t_{VCS}$	2	—	—	$\mu\text{s}$	
Data output delay time	$t_{OE}$	0	—	500	ns	

Note:  $t_{DF}$  is defined at the point where the output level can no longer be referenced after output goes to high-impedance state.

Switching characteristics  
 Input pulse level: 0.8 V to 2.2 V  
 Input rise/fall time:  $\leq 20$  ns  
 Input timing reference levels: 1.0 V, 2.0 V  
 Output timing reference levels: 0.8 V, 2.0V

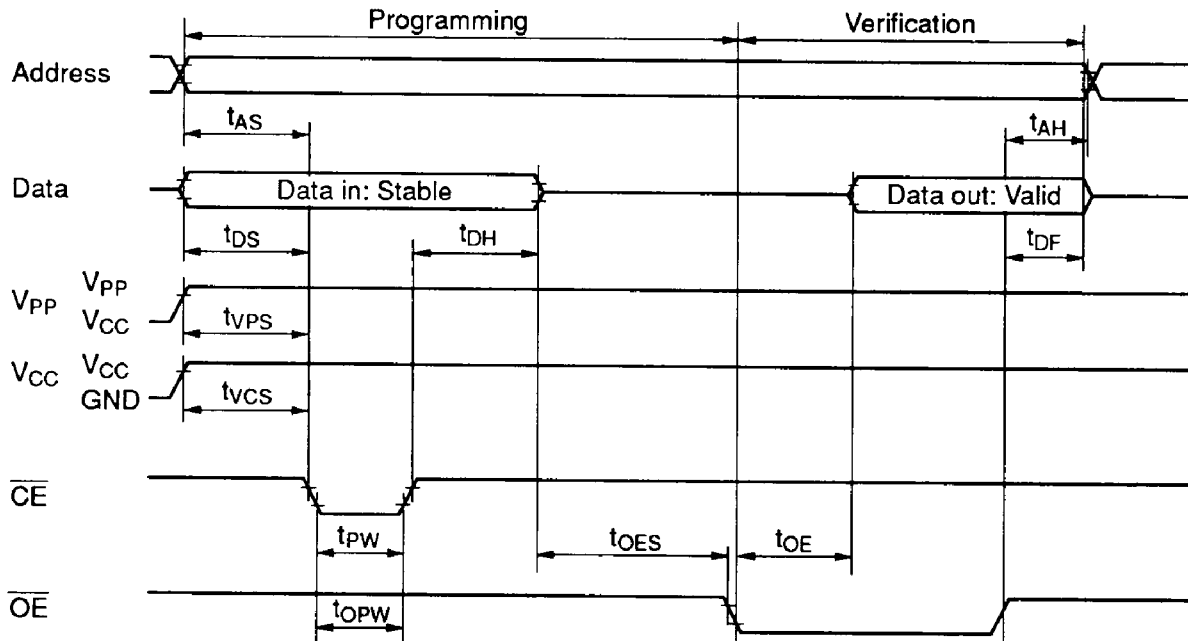

Figure 61 PROM Programming/Verification Timing

**Notes on PROM Programming**

**Principles of Programming/Erase:** A memory cell in a ZTAT™ microcomputer is the same as an EPROM cell: it is programmed by applying a high voltage between its control gate and drain to inject hot electrons into its floating gate. These electrons are stable, surrounded by an energy barrier formed by an SiO<sub>2</sub> film. The change in threshold voltage of a memory cell with a charged floating gate makes the corresponding bit appear as 0; a cell whose floating gate is not charged appears as 1 (figure 62).

The charge in a memory cell may decrease with time. This decrease is usually due to the following causes:

- Ultraviolet light excites electrons, allowing them to escape. This effect is the basis of the erasure principle.
- Heat excites trapped electrons, allowing them to escape.
- High voltages between control gate and drain may erase electrons.

If the oxide film covering a floating gate is defective, the electron erasure rate will be greater. However, electron erasure does not often occur because defective devices are detected and removed during screening tests.

**PROM Programming:** PROM memory cells must be programmed under specific voltage and timing conditions. The higher the programming voltage  $V_{pp}$  and the longer the programming pulse  $t_{pw}$  is applied, the more electrons are injected into the floating gates. However, if  $V_{pp}$  exceeds specifications, the pn junctions may be permanently damaged. Pay particular attention to overshooting in the PROM programmer. In addition, note that negative voltage noise will produce a parasitic transistor effect that may reduce breakdown voltages.

The ZTAT™ microcomputer is electrically connected to the PROM programmer by a socket adapter. Therefore, note the following points:

- Check that the socket adapter is firmly mounted on the PROM programmer.
- Do not touch the socket adapter or the LSI during the programming. Touching them may affect the quality of the contacts, which will cause programming errors.

**PROM Reliability after Programming:** In general, semiconductor devices retain their reliability, provided that some initial defects can be excluded. These initial defects can be detected and rejected by screening. Baking devices under high-temperature conditions is one method of screening that can rapidly eliminate data-hold defects in memory cells. (Refer to the Principles of Programming/Erase section.)

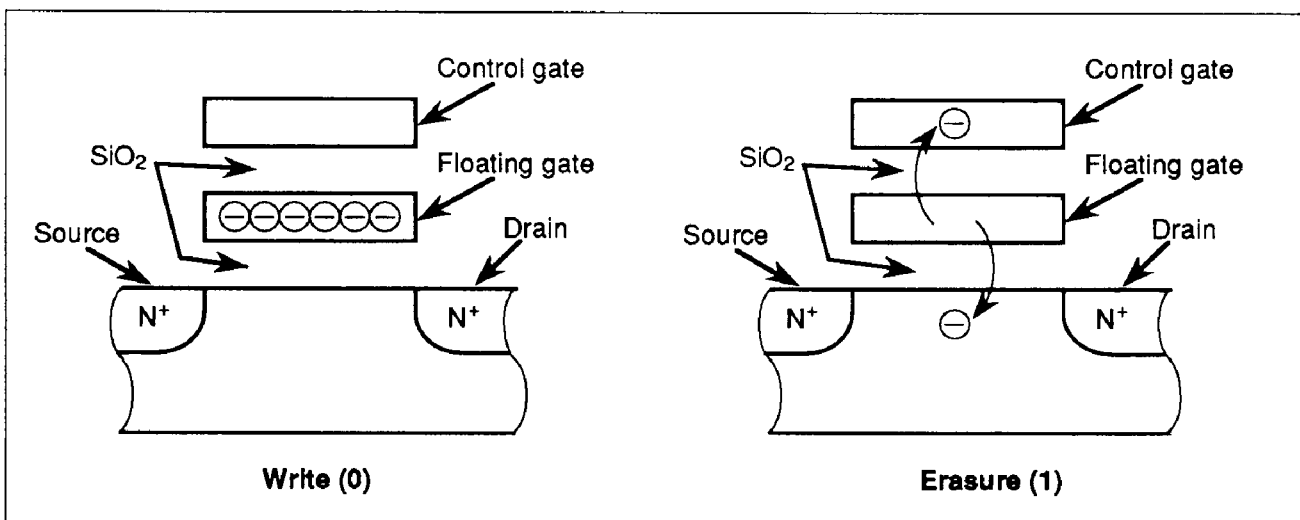

Figure 62 Cross-Sections of a EPROM Cell

ZTAT™ microcomputer devices are highly reliable because they have been subjected to such a screening method during the wafer fabrication process, but it is recommended that each device be exposed to 150°C at one atmosphere for at least 48 hours after it is programmed, to ensure its best performance. The recommended screening process is shown in figure 63.

Note: If programming errors occur continuously during PROM programming, suspend programming and check for problems in the PROM programmer or socket adapter. If programming verification indicates errors in programming or after high-temperature exposure, please inform Hitachi.

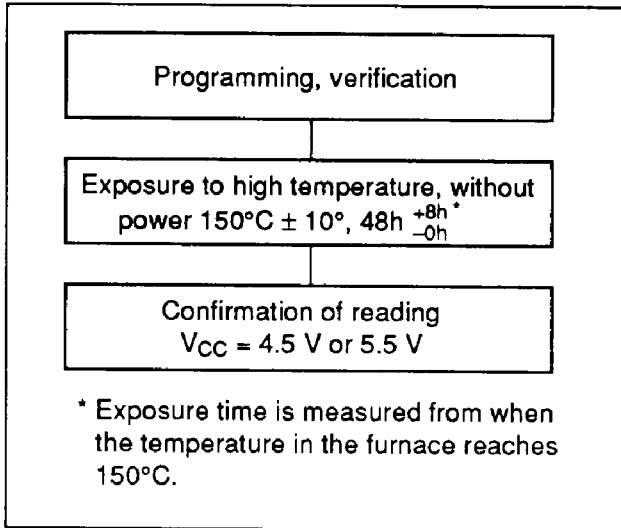

Figure 63 Recommended Screening Procedure



## Addressing Modes

### RAM Addressing Modes

The MCU has three RAM addressing modes, as shown in figure 64 and described below.

**Register Indirect Addressing Mode:** The contents of the W, X, and Y registers (10 bits in total) are used as a RAM address.

**Direct Addressing Mode:** A direct addressing instruction consists of two words. The first word contains the opcode, and the contents of the second word (10 bits) are used as a RAM address.

**Memory Register Addressing Mode:** The memory registers (MR), located in 16 digits from \$040 to \$04F, are accessed with the LAMR and XMRA instructions.

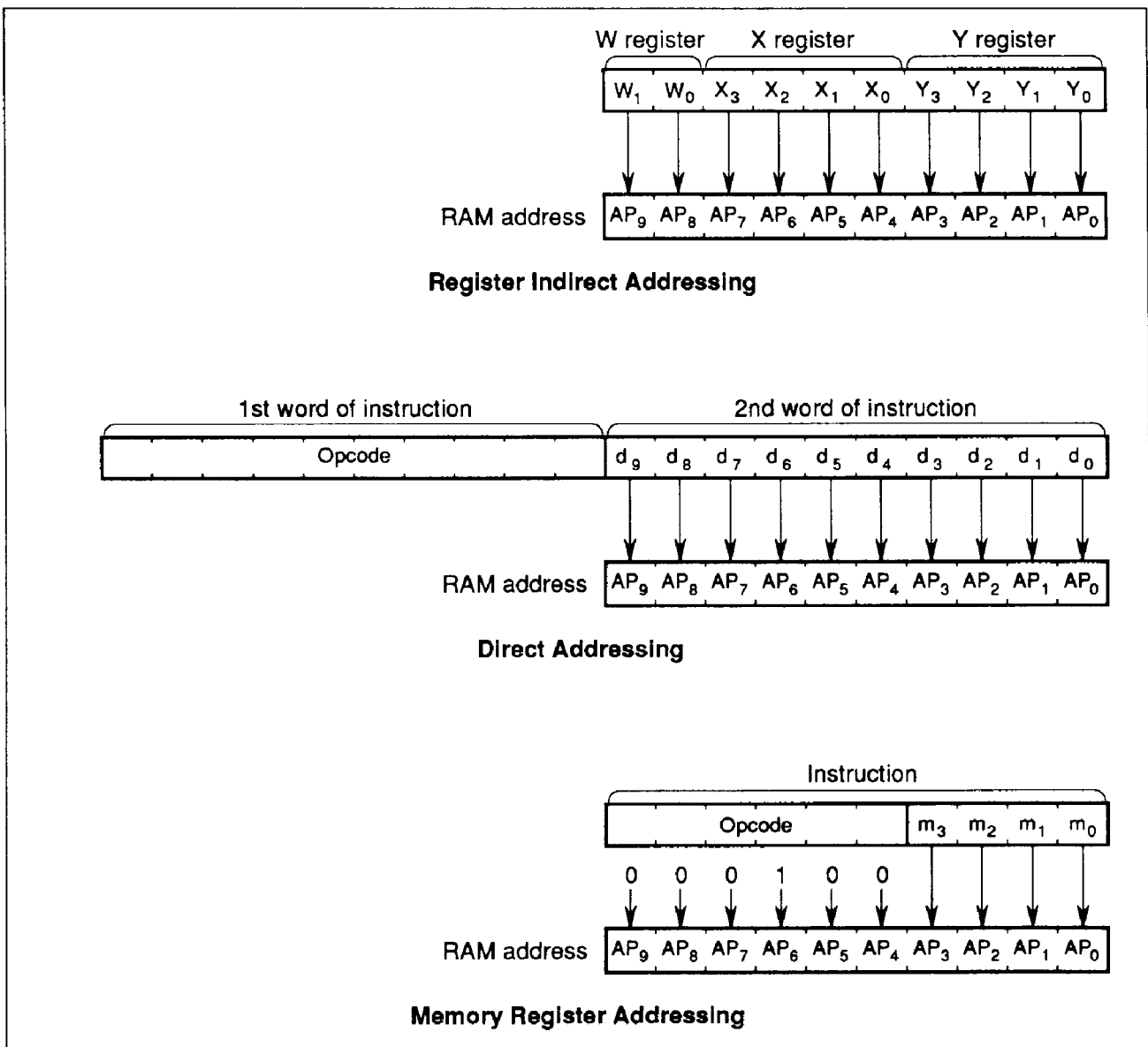

Figure 64 RAM Addressing Modes

## ROM Addressing Modes and the P Instruction

The MCU has four ROM addressing modes, as shown in figure 65, and the P instruction shown in figure 66.

**Direct Addressing Mode:** A program can branch to any address in the ROM memory space by executing the JMPL, BRL, or CALL instruction. Each of these instructions replaces the 14 program counter bits ( $PC_{13}$ – $PC_0$ ) with 14-bit immediate data.

**Current Page Addressing Mode:** The MCU has 64 pages of ROM with 256 words per page. A program can branch to any address in the current page by executing the BR instruction. This instruction replaces the eight low-order bits of the program counter ( $PC_7$ – $PC_0$ ) with eight-bit immediate data. If the BR instruction is on a page boundary (address  $256n + 255$ ), executing that instruction transmits the PC contents to the next physical page, as shown in figure 67. This means that the execution of the BR instruction on a page boundary will make the program branch to the next page.

Note that the HMCS400-series cross macroassembler has an automatic paging feature for ROM pages.

**Zero-Page Addressing Mode:** A program can branch to the zero-page subroutine area located at \$0000–\$003F by executing the CAL instruction. When the CAL instruction is executed, 6 bits of immediate data are placed in the six low-order bits of the program counter ( $PC_5$ – $PC_0$ ), and 0s are placed in the eight high-order bits ( $PC_{13}$ – $PC_6$ ).

**Table Data Addressing Mode:** A program can branch to an address determined by the contents of four-bit immediate data, the accumulator, and the B register by executing the TBR instruction.

**P Instruction:** ROM data addressed in table data addressing mode can be referenced by the P instruction as shown in figure 65. If bit 8 of the ROM data is 1, eight bits of ROM data are written to the accumulator and the B register. If bit 9 is 1, eight bits of ROM data are written to the R1 and R2 port output registers. If both bits 8 and 9 are 1, ROM data is written to the accumulator and the B register, and also to the R1 and R2 port output registers at the same time.

The P instruction has no effect on the program counter.

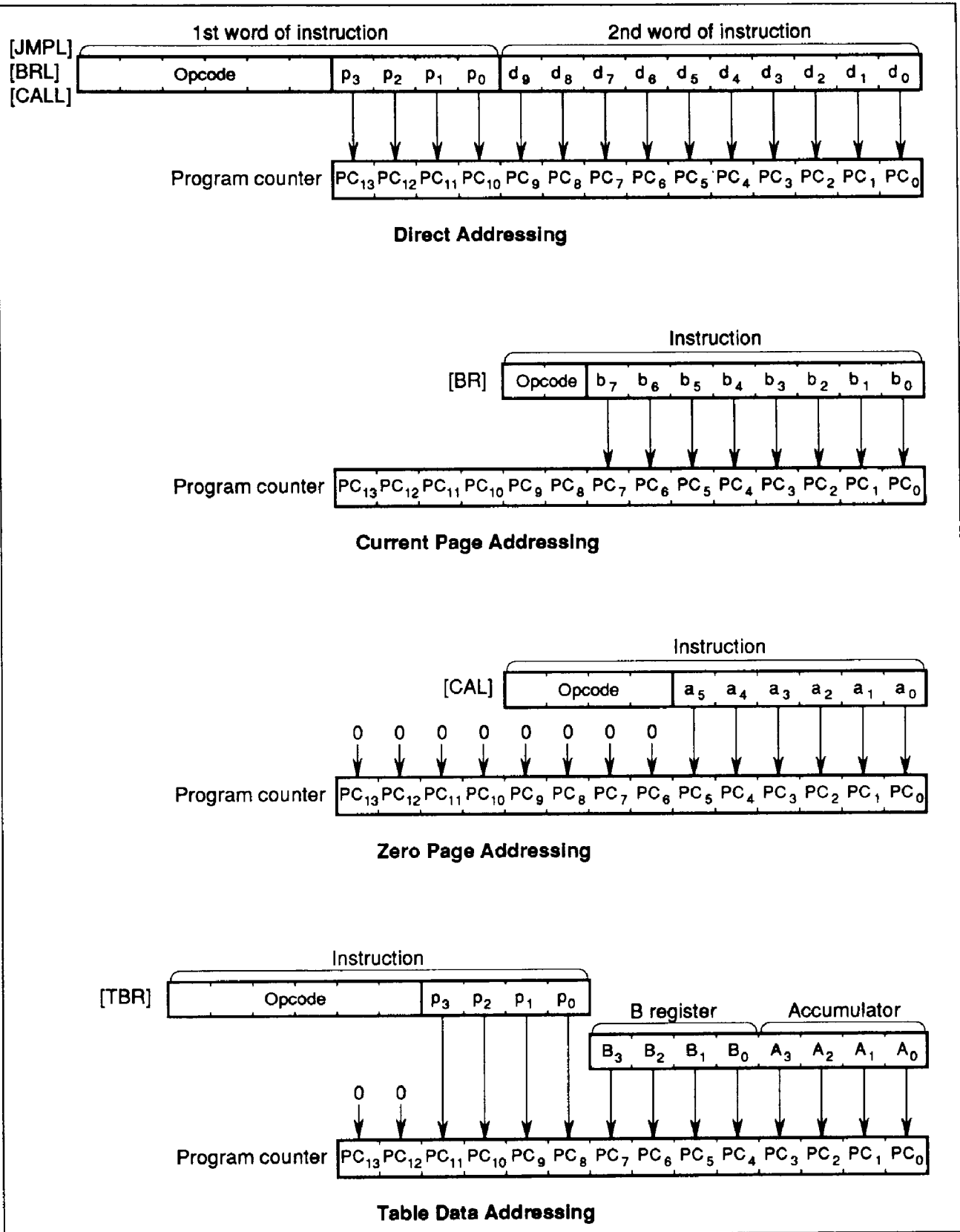

Figure 65 ROM Addressing Modes

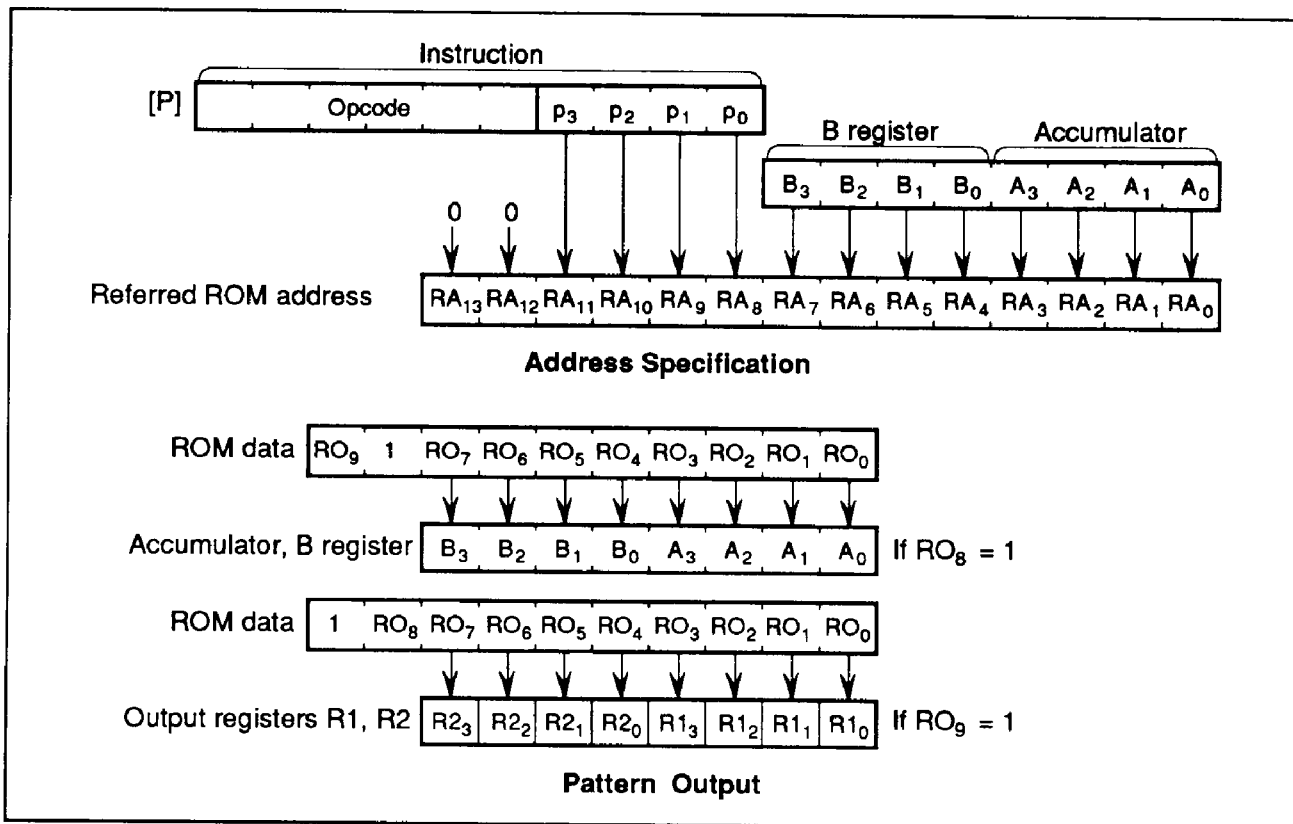

Figure 66 P Instruction

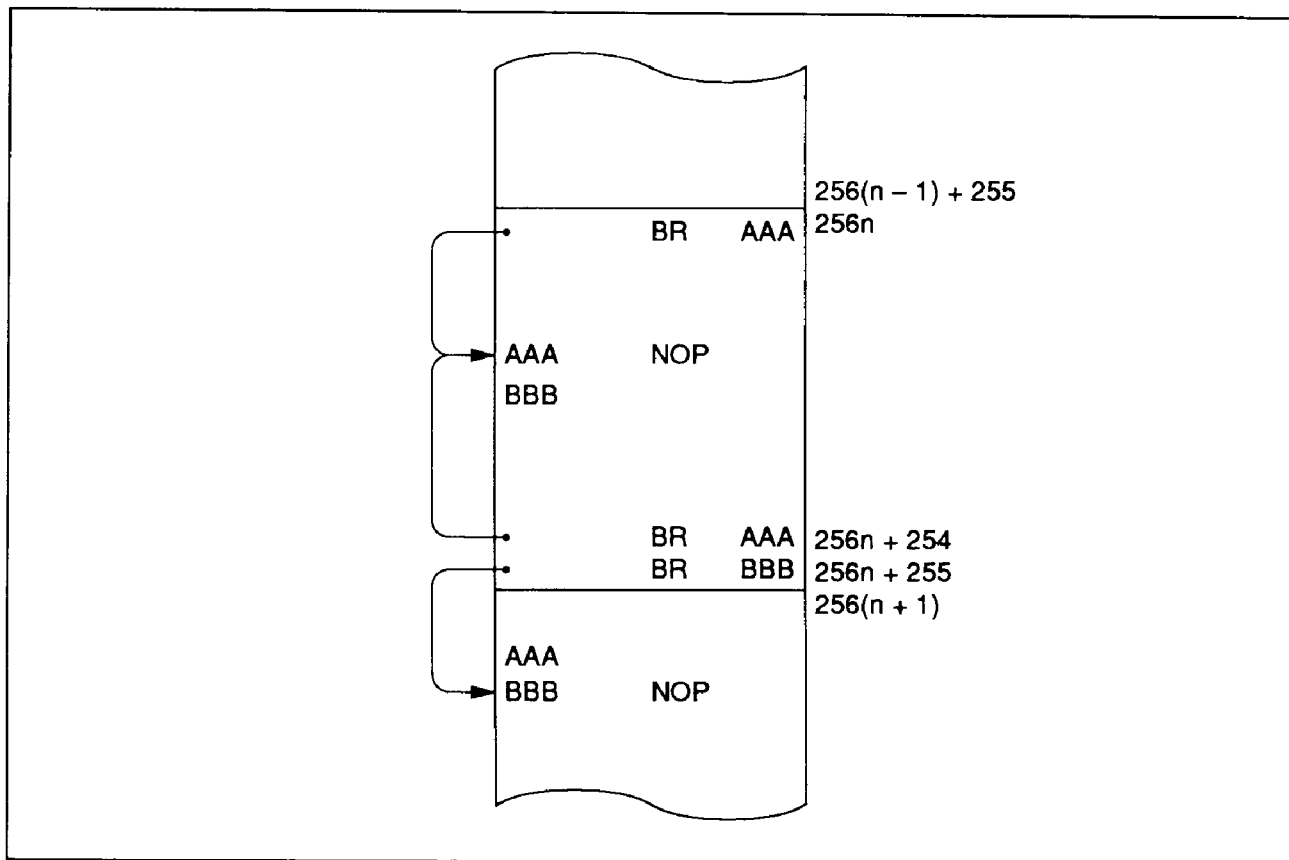

Figure 67 Branching when Branch Destination is on a Page Boundary

**Absolute Maximum Ratings**

Item	Symbol	Value	Unit	Notes
Supply voltage	$V_{CC}$	-0.3 to +7.0	V	
Programming voltage	$V_{PP}$	-0.3 to +14.0	V	12
Pin voltage	$V_T$	-0.3 to $V_{CC} + 0.3$	V	3
		$V_{CC} - 45$ to $V_{CC} + 0.3$	V	4
Total permissible input current	$\Sigma I_o$	50	mA	5
Total permissible output current	$-\Sigma I_o$	150	mA	6
Maximum input current	$I_o$	15	mA	7, 8
Maximum output current	$-I_o$	4	mA	9, 10
		30	mA	9, 11
Operating temperature	$T_{opr}$	-20 to +75	°C	
Storage temperature	$T_{stg}$	-55 to +125	°C	
Storage temperature (bias)	$T_{bias}$	-25 to +80	°C	12

- Notes:
1. Permanent damage may occur if these absolute maximum ratings are exceeded. Normal operation must be under the conditions stated in the electrical characteristics tables. If these conditions are exceeded, the LSI may malfunction or its reliability may be affected.
  2. All voltages are with respect to GND.
  3. Standard pins.
  4. High-voltage pins.
  5. The total permissible input current is the total of input currents simultaneously flowing in from all I/O pins to GND.
  6. The total permissible output current is the total of output currents simultaneously flowing out from  $V_{CC}$  to all I/O pins.
  7. The maximum input current is the maximum current flowing from any I/O pin to GND.
  8. Applies to R5–RD.
  9. The maximum output current is the maximum current flowing from  $V_{CC}$  to any I/O pin.
  10. Applies to R6–RB.
  11. Applies to D0–D15 and R0–R4.
  12. Applies to HD4074719.

### HD404719 Electrical Characteristics

DC Characteristics ( $V_{CC} = 3.0$  to  $6.0$  V,  $GND = 0.0$  V,  $V_{disp} = V_{CC} - 40$  V to  $V_{CC}$ ,  $T_a = -20^\circ$  to  $+75^\circ$ C, unless otherwise specified)

Item	Symbol	Pin(s)	Min	Typ	Max	Unit	Test Condition	Notes
Input high voltage	$V_{IH}$	RESET, $\overline{SCR}_1$ , $\overline{SCR}_2$ , INT <sub>0</sub> –INT <sub>5</sub>	$0.85V_{CC}$	—	$V_{CC} + 0.3$	V		
		SI <sub>1</sub> , SI <sub>2</sub>	$0.7V_{CC}$	—	$V_{CC} + 0.3$	V		
		OSC <sub>1</sub>	$V_{CC} - 0.5$	—	$V_{CC} + 0.3$	V	$V_{CC} = 3.5$ to $6.0$ V	
			$V_{CC} - 0.3$	—	$V_{CC} + 0.3$	V		
Input low voltage	$V_{IL}$	RESET, $\overline{SCR}_1$ , $\overline{SCR}_2$ , INT <sub>0</sub> –INT <sub>5</sub>	-0.3	—	$0.2V_{CC}$	V		
		SI <sub>1</sub> , SI <sub>2</sub>	-0.3	—	$0.3V_{CC}$	V		
		OSC <sub>1</sub>	-0.3	—	0.5	V	$V_{CC} = 3.5$ to $6.0$ V	
			-0.3	—	0.3	V		
Output high voltage	$V_{OH}$	$\overline{SCR}_1$ , $\overline{SCR}_2$ , SO <sub>1</sub> , SO <sub>2</sub> , BUZZ, TOC, TOD, TOE <sub>1</sub> , TOE <sub>2</sub> , TOG	$V_{CC} - 1.0$	—	—	V	$-I_{OH} = 1.0$ mA, $V_{CC} = 3.5$ to $6.0$ V	
			$V_{CC} - 0.5$	—	—	V	$-I_{OH} = 0.5$ mA, $V_{CC} = 3.5$ to $6.0$ V	
							$-I_{OH} = 0.3$ mA	
Output low voltage	$V_{OL}$	$\overline{SCR}_1$ , $\overline{SCR}_2$ , SO <sub>1</sub> , SO <sub>2</sub> , BUZZ, TOC, TOD, TOE <sub>1</sub> , TOE <sub>2</sub> , TOG	—	—	0.4	V	$I_{OL} = 1.6$ mA, $V_{CC} = 3.5$ to $6.0$ V  $I_{OL} = 0.4$ mA	
I/O leakage current	$ I_{IL} $	RESET, $\overline{SCR}_1$ , $\overline{SCR}_2$ , SI <sub>1</sub> , SI <sub>2</sub> , SO <sub>1</sub> , SO <sub>2</sub> , BUZZ, OSC <sub>1</sub> , TOC, TOD, TOE <sub>1</sub> , TOE <sub>2</sub> , TOG	—	—	1	$\mu$ A	$V_{in} = 0$ V to $V_{CC}$	1

Notes: 1. Excluding output buffer current.

# HD404719/HD404439/HD4074719

DC Characteristics ( $V_{CC} = 3.0$  to  $6.0$  V,  $GND = 0.0$  V,  $V_{disp} = V_{CC} - 40$  V to  $V_{CC}$ ,  $T_a = -20^\circ$  to  $+75^\circ$ C, unless otherwise specified) (cont)

Item	Symbol	Pin(s)	Min	Typ	Max	Unit	Test Condition	Notes
Current dissipation in active mode	$I_{CC}$	$V_{CC}$	—	—	8.0	mA	$V_{CC} = 5$ V, $f_{OSC} = 4$ MHz, digital input mode	2, 5
			—	—	4.5	mA	$V_{CC} = 3$ V, $f_{OSC} = 2$ MHz, digital input mode	2, 5
	$I_{CMP}$	$V_{CC}$	—	—	12.0	mA	$V_{CC} = 5$ V, $f_{OSC} = 4$ MHz, analog input mode	3, 5
			—	—	7.0	mA	$V_{CC} = 3$ V, $f_{OSC} = 2$ MHz, analog input mode	3, 5
Current dissipation in standby mode	$I_{SBY}$	$V_{CC}$	—	—	3.0	mA	$V_{CC} = 5$ V, $f_{OSC} = 4$ MHz	4, 5
			—	—	1.5	mA	$V_{CC} = 3$ V, $f_{OSC} = 2$ MHz	4, 5
Current dissipation in subactive mode	$I_{SUB}$	$V_{CC}$	—	—	70	$\mu$ A	$V_{in( TEST )} = V_{CC} - 0.3$ V to $V_{CC}$ $V_{in( RESET )} = 0$ to $0.3$ V, $V_{CC} = 3$ V, 32.768-kHz crystal oscillator	6, 7
Current dissipation in watch mode	$I_{WATCH}$	$V_{CC}$	—	—	15	$\mu$ A	$V_{in( TEST )} = V_{CC} - 0.3$ V to $V_{CC}$ , $V_{in( RESET )} = 0$ to $0.3$ V, $V_{CC} = 3$ V, 32.768-kHz crystal oscillator	6, 7, 8
Current dissipation in stop mode	$I_{STOP}$	$V_{CC}$	—	—	10	$\mu$ A	$V_{in( TEST )} = V_{CC} - 0.3$ V to $V_{CC}$ , $V_{in( RESET )} = 0$ to $0.3$ V, no 32.768-kHz oscillator	6
Watch mode retaining voltage	$V_{WATCH}$	$V_{CC}$	3.5	—	6.0	V	$V_{CC} = 3.5$ to $6.0$ V	7, 8
			3.0	—	6.0	V		
Stop mode retaining voltage	$V_{STOP}$	$V_{CC}$	2	—	—	V	No 32.768-kHz oscillator	

Refer to notes on next page.

DC Characteristics ( $V_{CC} = 3.0$  to  $6.0$  V,  $GND = 0.0$  V,  $V_{disp} = V_{CC} - 40$  V to  $V_{CC}$ ,  $T_a = -20^\circ$  to  $+75^\circ$ C, unless otherwise specified) (cont)

Item	Symbol	Pin(s)	Min	Typ	Max	Unit	Test Condition	Notes
Input high voltage	$V_{IHA}$	R6 <sub>0</sub> /COMP	$V_{ref} + 0.1$	—	—	V	Analog compare mode	
Input low voltage	$V_{ILA}$	R6 <sub>0</sub> /COMP	—	—	$V_{ref} - 0.1$	V	Analog compare mode	
Range of analog input reference voltage	$V_{ref}$	R6 <sub>1</sub> / $V_{ref}$	0	—	$V_{CC} - 1.2$	V		
Allowable error of internal reference voltage	$V_{OFS}$		-100	—	+100	mV	$V_{OFS} = \text{reference voltage} - V_{ref}$	9

- Notes:
- $I_{CC}$  is the source current when no I/O current is flowing while the MCU is in reset state.  
Test conditions: MCU: Reset  
Pins: RESET, TEST at  $V_{CC}$   
R5<sub>1</sub>-RD at  $V_{CC}$   
D<sub>0</sub>-D<sub>15</sub>, R0-R3, R4, R5<sub>0</sub> at  $V_{disp}$
  - $I_{CMP}$  is the source current when no I/O current is flowing while the R6<sub>0</sub>/COMP pin is in analog input mode.  
TEST conditions: Pins: R6<sub>0</sub>/COMP, R6<sub>1</sub>/ $V_{ref}$  at GND
  - $I_{SBY}$  is the source current when no I/O current is flowing while the MCU timer is in operation.  
Test conditions: MCU: I/O same as at reset  
Standby mode  
Pins: RESET at GND  
TEST at  $V_{CC}$   
R5<sub>1</sub>-RD at  $V_{CC}$   
D<sub>0</sub>-D<sub>15</sub>, R0-R3, R4, R5<sub>0</sub> at  $V_{disp}$
  - Power dissipation, while the MCU is operating or in standby mode, is in proportion to  $f_{OSC}$ . The value of the dissipation current when  $f_{OSC} = \chi$  MHz is given by the following equation:  
Maximum value ( $f_{OSC} = \chi$  MHz) =  $\chi/4 \times$  maximum value ( $f_{OSC} = 4$  MHz)
  - Source current when no I/O current is flowing.  
Test conditions: Pins: R5<sub>1</sub>-RD at  $V_{CC}$   
D<sub>0</sub>-D<sub>15</sub>, R0-R4, R5<sub>0</sub> at GND
  - Applies when '32-kHz CPU operation' is selected as an optional function.
  - Applies when 'no 32-kHz CPU operation with clock time base' is selected as an optional function.
  - The reference voltage is the expected internal  $V_{ref}$  voltage selected by the compare control register (CCR).  
Example: when CCR = \$9, reference voltage is  $2/11 \times V_{CC}$ .



# HD404719/HD404439/HD4074719

A/D Converter ( $V_{CC} = 3.0$  to  $6.0$  V, AGND = GND,  $T_a = -20^\circ$  to  $+75^\circ\text{C}$ , unless otherwise specified)

Item	Symbol	Pin(s)	Min	Typ	Max	Unit	Test Condition	Notes
Analog supply voltage	$AV_{CC}$	$AV_{CC}$	$V_{CC} - 0.3$	$V_{CC}$	$V_{CC} + 0.3$	V		
Analog input voltage	$AV_{in}$	$AN_0$ – $AN_7$	AGND	—	$AV_{CC}$	V		1
Current between $AV_{CC}$ and AGND	$AI_{CC}$	$AV_{CC}$	—	—	150	$\mu\text{A}$	$AV_{CC} = 5\text{V}$ , $V_{in(\text{RESET})} = 0$ to $0.3\text{V}$ , $V_{in(\text{TEST})} =$ $V_{CC} - 0.3\text{V}$ to $V_{CC}$	
	$AI_{\text{STOP}}$	$AV_{CC}$	—	—	10	$\mu\text{A}$	$V_{in(\text{RESET})} = 0$ to $0.3\text{V}$ , $V_{in(\text{TEST})} =$ $V_{CC} - 0.3\text{V}$ to $V_{CC}$ , stop mode, no 32.768-kHz oscillator	
Analog input capacitance	$C_{ain}$	$AN_0$ – $AN_7$	—	—	30	pF		
Resolution			—	—	8	Bit		
Number of input channels			0	—	8	Channel		
Absolute error			—	—	$\pm 2.5$	LSB	$T_a = 25^\circ\text{C}$ , $AV_{CC} = 5\text{V}$	

Notes: 1. Select without pull-up MOS option for pins RC and RD when using these pins as analog input pins.

# HD404719/HD404439/HD4074719

**Input/Output Characteristics for Standard Pins** ( $V_{CC} = 3.0$  to  $6.0$  V,  $GND = 0.0$  V,  
 $V_{disp} = V_{CC} - 40$  V to  $V_{CC}$ ,  $T_a = -20^\circ$  to  $+75^\circ$ C, unless otherwise specified)

Item	Symbol	Pins	Min	Typ	Max	Unit	Test Condition	Notes
Input high voltage	$V_{IH}$	R5 <sub>1</sub> -RD	$0.7V_{CC}$	—	$V_{CC} + 0.3$	V		
Input low voltage	$V_{IL}$	R5 <sub>1</sub> -RD	-0.3	—	$0.3V_{CC}$	V		
Output high voltage	$V_{OH}$	R6-RB	$V_{CC} - 1.0$	—	—	V	$-I_{OH} = 1.0$ mA, $V_{CC} = 3.5$ to $6.0$ V	
			$V_{CC} - 0.5$	—	—	V	$-I_{OH} = 0.5$ mA, $V_{CC} = 3.5$ to $6.0$ V	
							$-I_{OH} = 0.3$ mA	
Output low voltage	$V_{OL}$	R6-RB	—	—	0.4	V	$I_{OL} = 1.6$ mA, $V_{CC} = 3.5$ to $6.0$ V $I_{OL} = 0.4$ mA	
Input/output leakage current	$ I_{IL} $	R6-RD, R5 <sub>1</sub> -R5 <sub>3</sub>	—	—	1	$\mu$ A	$V_{in} = 0$ V to $V_{CC}$	1
Pull-up MOS current	$I_p$	R5 <sub>1</sub> -RD	30	80	160	$\mu$ A	$V_{CC} = 5$ V, $V_{in} = 0$ V	2
			10	30	60		$V_{CC} = 3$ V, $V_{in} = 0$ V	

- Notes: 1. Excluding output buffer current.  
 2. Applies to I/O pins selected as with pull-up MOS by mask option.

# HD404719/HD404439/HD4074719

**Input/Output Characteristics for High-Voltage Pins** ( $V_{CC} = 3.0$  to  $6.0$  V,  $GND = 0.0$  V,  $V_{disp} = V_{CC} - 40$  V to  $V_{CC}$ ,  $T_a = -20^\circ$  to  $+75^\circ$  C, unless otherwise specified)

Item	Symbol	Pins	Min	Typ	Max	Unit	Test Condition	Notes
Input high voltage	$V_{IH}$	D <sub>0</sub> -D <sub>15</sub> , R <sub>50</sub> , R <sub>0</sub> -R <sub>4</sub>	$0.7V_{CC}$	—	$V_{CC} + 0.3$	V		
Input low voltage	$V_{IL}$	D <sub>0</sub> -D <sub>15</sub> , R <sub>50</sub> , R <sub>0</sub> -R <sub>4</sub>	$V_{CC} - 40$	—	$0.3V_{CC}$	V		
Output high voltage	$V_{OH}$	D <sub>0</sub> -D <sub>15</sub> , R <sub>0</sub> -R <sub>4</sub>	$V_{CC} - 3.0$	—	—	V	$-I_{OH} = 15$ mA, $V_{CC} = 4$ V to 6 V	
			$V_{CC} - 2.0$	—	—	V	$-I_{OH} = 10$ mA, $V_{CC} = 4$ V to 6 V	
			$V_{CC} - 1.0$	—	—	V	$-I_{OH} = 4$ mA	
Output low voltage	$V_{OL}$	D <sub>0</sub> -D <sub>15</sub> , R <sub>0</sub> -R <sub>4</sub>	—	—	$V_{CC} - 37$	V	$V_{disp} = V_{CC} - 40$ V	1
			—	—	$V_{CC} - 37$	V	150 k $\Omega$ at $V_{CC} - 40$ V	2
Input/output leakage current	$ I_{IL} $	D <sub>0</sub> -D <sub>15</sub> , R <sub>50</sub> , R <sub>0</sub> -R <sub>4</sub>	—	—	20	$\mu$ A	$V_{in} = V_{CC} - 40$ V to $V_{CC}$	3
Pull-down MOS current	$I_d$	D <sub>0</sub> -D <sub>15</sub> , R <sub>0</sub> -R <sub>4</sub>	200	400	800	$\mu$ A	$V_{disp} = V_{CC} - 35$ V, $V_{in} = V_{CC}$	1

- Notes:
1. Applied to I/O pins selected as with pull-up MOS by mask option.
  2. Applied to I/O pins selected as without pull-up MOS (PMOS open drain) by mask option.
  3. Pull-up MOS current and output buffer current are excluded.

# HD404719/HD404439/HD4074719

**AC Characteristics** ( $V_{CC} = 3.0$  to  $6.0$  V,  $GND = 0.0$  V,  $V_{disp} = V_{CC} - 40$  V to  $V_{CC}$ ,  $T_a = -20^\circ$  to  $+75^\circ\text{C}$ , unless otherwise specified)

Item	Symbol	Pin(s)	Min	Typ	Max	Unit	Test Condition	Notes
Oscillation frequency (1/4 division)	$f_{OSC}$	OSC <sub>1</sub> , OSC <sub>2</sub>	1.6	4	4.5	MHz	$V_{CC} = 3.5$ to $6.0$ V	
			1.6	2	2.25	MHz		
Oscillation frequency (1/8 division)	$f_{CL}$	CL <sub>1</sub> , CL <sub>2</sub>	—	32.768	—	kHz		
Instruction cycle time	$t_{cyc}$		0.89	1	2.5	$\mu\text{s}$	$V_{CC} = 3.5$ to $6.0$ V	
			1.78	2	2.5	$\mu\text{s}$		
Instruction cycle time	$t_{SUBcyc}$		—	244.14	—	$\mu\text{s}$		6
Oscillation stabilization time (crystal oscillator)	$t_{RC}$	OSC <sub>1</sub> , OSC <sub>2</sub>	—	—	40	ms	$V_{CC} = 3.5$ to $6.0$ V	1
			—	—	60	ms		1
Oscillation stabilization time (ceramic oscillator)	$t_{RC}$	OSC <sub>1</sub> , OSC <sub>2</sub>	—	—	20	ms	$V_{CC} = 3.5$ to $6.0$ V	1
			—	—	60	ms		1
Oscillation stabilization time	$t_{RC}$	CL <sub>1</sub> , CL <sub>2</sub>	—	—	2	s		2
External clock high width	$t_{CPH}$	OSC <sub>1</sub>	92	—	—	ns	$V_{CC} = 3.5$ to $6.0$ V	3
			203	—	—	ns		3
External clock low width	$t_{CPL}$	OSC <sub>1</sub>	92	—	—	ns	$V_{CC} = 3.5$ to $6.0$ V	3
			203	—	—	ns		3
External clock rise time	$t_{CPr}$	OSC <sub>1</sub>	—	—	20	ns	$V_{CC} = 3.5$ to $6.0$ V	3
			—	—	20	ns		3
External clock fall time	$t_{CPr}$	OSC <sub>1</sub>	—	—	20	ns	$V_{CC} = 3.5$ to $6.0$ V	3
			—	—	20	ns		3
INT <sub>0</sub> high width	$t_{I0H}$	INT <sub>0</sub>	2	—	—	$t_{cyc}/t_{SUBcyc}$		4, 6
INT <sub>0</sub> low width	$t_{I0L}$	INT <sub>0</sub>	2	—	—	$t_{cyc}/t_{SUBcyc}$		4, 6
INT high width	$t_{I1H}$	INT <sub>1</sub> –INT <sub>5</sub>	2	—	—	$t_{cyc}$		4
INT low width	$t_{I1L}$	INT <sub>1</sub> –INT <sub>5</sub>	2	—	—	$t_{cyc}$		4

# HD404719/HD404439/HD4074719

**AC Characteristics** ( $V_{CC} = 3.0$  to  $6.0$  V,  $GND = 0.0$  V,  $V_{disp} = V_{CC} - 40$  V to  $V_{CC}$ ,  $T_a = -20^\circ$  to  $+75^\circ\text{C}$ , unless otherwise specified) (cont)

Item	Symbol	Pin(s)	Min	Typ	Max	Unit	Test Condition	Notes
RESET high width	$t_{RSTH}$	RESET	2	—	—	$t_{cyc}$		5
Input capacitance	$C_{in}$	All pins	—	—	30	pF	$f = 1$ MHz, $V_{in} = 0$ V	
Analog comparator stabilization time	$t_{cstb}$	R6 <sub>0</sub> /COMP	—	—	2	$t_{cyc}$		7

- Notes:
1. The oscillation stabilization time is the period required for the oscillator to stabilize after  $V_{CC}$  reaches 3.0 V (3.5 V if  $V_{CC} = 3.5$  to  $6.0$  V) at power-on or after RESET input goes high after stop mode is cancelled (figure 68). At power-on and when stop mode is cancelled, RESET must remain high for at least  $t_{PC}$  to ensure the oscillation stabilization time. If using an oscillator, contact the oscillator manufacturer to determine the circuit constants, since the stabilization time depends on the circuit constants and stray capacitances.
  2. The oscillation stabilization time is the period required for the oscillator to stabilize after  $V_{CC}$  reaches 3.0 V at power-on (figure 69). If using a crystal oscillator, contact the manufacturer to determine the circuit constants, since the stabilization time depends on the circuit constants and stray capacitances.
  3. Refer to figure 70.
  4. Refer to figure 71.
  5. Refer to figure 72. The MCU will malfunction if noise interferes with the falling edge of the RESET signal when releasing from reset state. The reset circuit must be sufficiently evaluated in the application system.
  6. The  $t_{SUBcyc}$  unit applies when the MCU is in watch or subactive mode.  
 $t_{SUBcyc} = 244.14 \mu\text{s}$  (32.768-kHz crystal)
  7. The analog comparator stabilization time is the period required for the analog comparator to stabilize and to read correct data after pin R6<sub>0</sub> switches to analog input mode.

**Serial Interface Timing Characteristics** ( $V_{CC} = 3.0$  to  $6.0$  V,  $GND = 0.0$  V,  $V_{dlsb} = V_{CC} - 40$  V to  $V_{CC}$ ,  $T_a = -20^\circ$  to  $+75^\circ\text{C}$ )

Item	Symbol	Pins	Min	Typ	Max	Unit	Test Condition	Notes
Output transmit clock cycle time	$t_{Scyc}$	SCK <sub>1</sub> , SCK <sub>2</sub>	1	—	—	$t_{cyc}$	Load shown in figure 74	1, 2
Output transmit clock high width	$t_{SCKH}$	SCK <sub>1</sub> , SCK <sub>2</sub>	0.4	—	—	$t_{Scyc}$		1, 2
Output transmit clock low width	$t_{SCKL}$	SCK <sub>1</sub> , SCK <sub>2</sub>	0.4	—	—	$t_{Scyc}$		1, 2
Output transmit clock rise time	$t_{SCKr}$	SCK <sub>1</sub> , SCK <sub>2</sub>	—	—	80	ns		1, 2
Output transmit clock fall time	$t_{SCKf}$	SCK <sub>1</sub> , SCK <sub>2</sub>	—	—	80	ns		1, 2
Input transmit clock cycle time	$t_{Scyc}$	SCK <sub>1</sub> , SCK <sub>2</sub>	2	—	—	$t_{cyc}$		1
Input transmit clock high width	$t_{SCKH}$	SCK <sub>1</sub> , SCK <sub>2</sub>	0.4	—	—	$t_{Scyc}$		1
Input transmit clock low width	$t_{SCKL}$	SCK <sub>1</sub> , SCK <sub>2</sub>	0.4	—	—	$t_{Scyc}$		1
Input transmit clock rise time	$t_{SCKr}$	SCK <sub>1</sub> , SCK <sub>2</sub>	—	—	80	ns		1
Input transmit clock fall time	$t_{SCKf}$	SCK <sub>1</sub> , SCK <sub>2</sub>	—	—	80	ns		1
Serial output data delay time	$t_{DSO}$	SO <sub>1</sub> , SO <sub>2</sub>	—	—	600	ns	Load shown in figure 74	1, 2
Serial input data setup time	$t_{SSI}$	SI <sub>1</sub> , SI <sub>2</sub>	200	—	—	ns		1
Serial input data hold time	$t_{HSI}$	SI <sub>1</sub> , SI <sub>2</sub>	400	—	—	ns		1

Notes: 1. Refer to figure 73.  
2. Refer to figure 74.

# HD404719/HD404439/HD4074719

## Serial Interface Timing Characteristics ( $V_{CC} = 3.5$ to $6.0$ V)

Item	Symbol	Pins	Min	Typ	Max	Unit	Test Condition	Notes
Output transmit clock cycle time	$t_{Scyc}$	$SCK_1$ , $SCK_2$	1	—	—	$t_{cyc}$	Load shown in figure 74	1, 2
Output transmit clock high width	$t_{SCKH}$	$SCK_1$ , $SCK_2$	0.4	—	—	$t_{Scyc}$		1, 2
Output transmit clock low width	$t_{SCKL}$	$SCK_1$ , $SCK_2$	0.4	—	—	$t_{Scyc}$		1, 2
Output transmit clock rise time	$t_{SCKr}$	$SCK_1$ , $SCK_2$	—	—	40	ns		1, 2
Output transmit clock fall time	$t_{SCKf}$	$SCK_1$ , $SCK_2$	—	—	40	ns		1, 2
Input transmit clock cycle time	$t_{Scyc}$	$SCK_1$ , $SCK_2$	2	—	—	$t_{cyc}$		1
Input transmit clock high width	$t_{SCKH}$	$SCK_1$ , $SCK_2$	0.4	—	—	$t_{Scyc}$		1
Input transmit clock low width	$t_{SCKL}$	$SCK_1$ , $SCK_2$	0.4	—	—	$t_{Scyc}$		1
Input transmit clock rise time	$t_{SCKr}$	$SCK_1$ , $SCK_2$	—	—	40	ns		1
Input transmit clock fall time	$t_{SCKf}$	$SCK_1$ , $SCK_2$	—	—	40	ns		1
Serial output data delay time	$t_{DSO}$	$SO_1$ , $SO_2$	—	—	300	ns	Load shown in figure 74	1, 2
Serial input data setup time	$t_{SSI}$	$SI_1$ , $SI_2$	100	—	—	ns		1
Serial input data hold time	$t_{HSI}$	$SI_1$ , $SI_2$	200	—	—	ns		1

Notes: 1. Refer to figure 73.  
2. Refer to figure 74.

HD404439 Electrical Characteristics

DC Characteristics ( $V_{CC} = 3.0$  to  $6.0$  V,  $GND = 0.0$  V,  $T_a = -20^\circ$  to  $+75^\circ$ C, unless otherwise specified)

Item	Symbol	Pin(s)	Min	Typ	Max	Unit	Test Condition	Notes
Input high voltage	$V_{IH}$	RESET, SCK <sub>1</sub> , SCK <sub>2</sub> , INT <sub>0</sub> -INT <sub>5</sub>	$0.85V_{CC}$	—	$V_{CC} + 0.3$	V		
		SI <sub>1</sub> , SI <sub>2</sub>	$0.7V_{CC}$	—	$V_{CC} + 0.3$	V		
		OSC <sub>1</sub>	$V_{CC} - 0.5$ $V_{CC} - 0.3$	—	$V_{CC} + 0.3$	V	$V_{CC} = 3.5$ to $6.0$ V	
Input low voltage	$V_{IL}$	RESET, SCK <sub>1</sub> , SCK <sub>2</sub> , INT <sub>0</sub> -INT <sub>5</sub>	-0.3	—	$0.2V_{CC}$	V		
		SI <sub>1</sub> , SI <sub>2</sub>	-0.3	—	$0.3V_{CC}$	V		
		OSC <sub>1</sub>	-0.3 -0.3	—	0.5 0.3	V	$V_{CC} = 3.5$ to $6.0$ V	
Output high voltage	$V_{OH}$	SCK <sub>1</sub> , SCK <sub>2</sub> , SO <sub>1</sub> , SO <sub>2</sub> , BUZZ, TOC, TOD, TOE <sub>1</sub> , TOE <sub>2</sub> , TOG	$V_{CC} - 1.0$ $V_{CC} - 0.5$	—	—	V	$-I_{OH} = 1.0$ mA, $V_{CC} = 3.5$ to $6.0$ V	
						V	$-I_{OH} = 0.5$ mA, $V_{CC} = 3.5$ to $6.0$ V	
Output low voltage	$V_{OL}$	SCK <sub>1</sub> , SCK <sub>2</sub> , SO <sub>1</sub> , SO <sub>2</sub> , BUZZ, TOC, TOD, TOE <sub>1</sub> , TOE <sub>2</sub> , TOG	—	—	0.4	V	$I_{OL} = 1.6$ mA, $V_{CC} = 3.5$ to $6.0$ V	
							$I_{OL} = 0.4$ mA	
I/O leakage current	$ I_{IL} $	RESET, SCK <sub>1</sub> , SCK <sub>2</sub> , SI <sub>1</sub> , SI <sub>2</sub> , SO <sub>1</sub> , SO <sub>2</sub> , BUZZ, OSC <sub>1</sub> , TOC, TOD, TOE <sub>1</sub> , TOE <sub>2</sub> , TOG	—	—	1	$\mu$ A	$V_{in} = 0$ V to $V_{CC}$	1

Notes: 1. Excluding output buffer current.



# HD404719/HD404439/HD4074719

DC Characteristics ( $V_{CC} = 3.0$  to  $6.0$  V,  $GND = 0.0$  V,  $T_a = -20^\circ$  to  $+75^\circ\text{C}$ , unless otherwise specified)  
(cont)

Item	Symbol	Pin(s)	Min	Typ	Max	Unit	Test Condition	Notes
Current dissipation in active mode	$I_{CC}$	$V_{CC}$	—	—	8.0	mA	$V_{CC} = 5$ V, $f_{OSC} = 4$ MHz, digital input mode	2, 5
			—	—	4.5	mA	$V_{CC} = 3$ V, $f_{OSC} = 2$ MHz, digital input mode	2, 5
	$I_{CMP}$	$V_{CC}$	—	—	12.0	mA	$V_{CC} = 5$ V, $f_{OSC} = 4$ MHz, analog input mode	3, 5
			—	—	7.0	mA	$V_{CC} = 3$ V, $f_{OSC} = 2$ MHz, 1/4 division ratio, analog input mode	3, 5
Current dissipation in standby mode	$I_{SBY}$	$V_{CC}$	—	—	3.0	mA	$V_{CC} = 5$ V, $f_{OSC} = 4$ MHz	4, 5
			—	—	1.5	mA	$V_{CC} = 3$ V, $f_{OSC} = 2$ MHz	4, 5
Current dissipation in subactive mode	$I_{SUB}$	$V_{CC}$	—	—	70	$\mu\text{A}$	$V_{in}(\text{TEST}) = V_{CC} - 0.3$ V to $V_{CC}$ $V_{in}(\text{RESET}) = 0$ to $0.3$ V, $V_{CC} = 3$ V, 32.768-kHz crystal oscillator	6, 7
Current dissipation in watch mode	$I_{WATCH}$	$V_{CC}$	—	—	15	$\mu\text{A}$	$V_{in}(\text{TEST}) = V_{CC} - 0.3$ V to $V_{CC}$ , $V_{in}(\text{RESET}) = 0$ to $0.3$ V, $V_{CC} = 3$ V, 32.768-kHz crystal oscillator	6, 7, 8
Current dissipation in stop mode	$I_{STOP}$	$V_{CC}$	—	—	10	$\mu\text{A}$	$V_{in}(\text{TEST}) = V_{CC} - 0.3$ V to $V_{CC}$ , $V_{in}(\text{RESET}) = 0$ to $0.3$ V, no 32.768-kHz oscillator	6
Watch mode retaining voltage	$V_{WATCH}$	$V_{CC}$	3.5	—	6.0	V	$V_{CC} = 3.5$ to $6.0$ V	6, 7, 8
			3.0	—	6.0	V		
Stop mode retaining voltage	$V_{STOP}$	$V_{CC}$	2	—	—	V	No 32.768-kHz oscillator	

**DC Characteristics ( $V_{CC} = 3.0$  to  $6.0$  V,  $GND = 0.0$  V,  $T_a = -20^\circ$  to  $+75^\circ\text{C}$ , unless otherwise specified)**  
(cont)

Item	Symbol	Pin(s)	Min	Typ	Max	Unit	Test Condition	Notes
Input high voltage	$V_{IHA}$	R6 <sub>0</sub> /COMP	$V_{ref} + 0.1$	—	—	V	Analog compare mode	
Input low voltage	$V_{ILA}$	R6 <sub>0</sub> /COMP	—	—	$V_{ref} - 0.1$	V	Analog compare mode	
Range of analog input reference voltage	$V_{ref}$	R6 <sub>1</sub> / $V_{ref}$	0	—	$V_{CC} - 1.2$	V		
Allowable error of internal reference voltage	$V_{OFS}$		-100	—	+100	mV	$V_{OFS} = \text{reference voltage} - V_{ref}$	9

- Notes:
- $I_{CC}$  is the source current when no I/O current is flowing while the MCU is in reset state.  
Test conditions: MCU: Reset  
Pins: RESET, TEST at  $V_{CC}$   
R5<sub>1</sub>-RD at  $V_{CC}$   
D<sub>0</sub>-D<sub>15</sub>, R0-R3, R4, R5<sub>0</sub> at GND
  - $I_{CMP}$  is the source current when no I/O current is flowing while the R6<sub>0</sub>/COMP pin is in analog input mode.  
TEST conditions: Pins: R6<sub>0</sub>/COMP, R6<sub>1</sub>/ $V_{ref}$  at GND
  - $I_{SBY}$  is the source current when no I/O current is flowing while the MCU timer is in operation.  
Test conditions: MCU: I/O same as at reset  
Standby mode  
Pins: RESET at GND  
TEST at  $V_{CC}$   
R5<sub>1</sub>-RD at  $V_{CC}$   
D<sub>0</sub>-D<sub>15</sub>, R0-R3, R4, R5<sub>0</sub> at GND
  - Power dissipation, while the MCU is operating or in standby mode, is in proportion to  $f_{OSC}$ . The value of the dissipation current when  $f_{OSC} = \chi$  MHz is given by the following equation:  
Maximum value ( $f_{OSC} = \chi$  MHz) =  $\chi/4 \times$  maximum value ( $f_{OSC} = 4$  MHz)
  - Source current when no I/O current is flowing.  
Test conditions: Pins: R5<sub>1</sub>-RD at  $V_{CC}$   
D<sub>0</sub>-D<sub>15</sub>, R0-R4, R5<sub>0</sub> at GND
  - Applies when '32-kHz CPU operation' is selected as an optional function.
  - Applies when 'no 32-kHz CPU operation with clock time base' is selected as an optional function.
  - The reference voltage is the expected internal  $V_{ref}$  voltage selected by the compare control register (CCR).

# HD404719/HD404439/HD4074719

**A/D Converter ( $V_{CC} = 3.0$  to  $6.0$  V,  $AGND = GND$ ,  $T_a = -20^\circ$  to  $+75^\circ C$ , unless otherwise specified)**

Item	Symbol	Pin(s)	Min	Typ	Max	Unit	Test Condition	Notes
Analog supply voltage	$AV_{CC}$	$AV_{CC}$	$V_{CC} - 0.3$	$V_{CC}$	$V_{CC} + 0.3$	V		
Analog input voltage	$AV_{in}$	$AN_0-AN_7$	AGND	—	$AV_{CC}$	V		1
Current between $AV_{CC}$ and AGND	$AI_{CC}$	$AV_{CC}$	—	—	150	$\mu A$	$AV_{CC} = 5$ V, $V_{in (RESET)} = 0$ to $0.3$ V, $V_{in (TEST)} =$ $V_{CC} - 0.3$ V to $V_{CC}$	
	$AI_{STOP}$	$AV_{CC}$	—	—	10	$\mu A$	$V_{in (RESET)} = 0$ to $0.3$ V, $V_{in (TEST)} =$ $V_{CC} - 0.3$ V to $V_{CC}$ , stop mode, no 32.768-kHz oscillator	
Analog input capacitance	$C_{ain}$	$AN_0-AN_7$	—	—	30	pF		
Resolution			—	—	8	Bit		
Number of input channels			0	—	8	Channel		
Absolute error			—	—	$\pm 2.5$	LSB	$T_a = 25^\circ C$ , $AV_{CC} = 5$ V	

Notes: 1. Select without pull-up MOS option for pins RC and RD when using these pins as analog input pins.

## HD404719/HD404439/HD4074719

**Input/Output Characteristics for Standard Pins** ( $V_{CC} = 3.0$  to  $6.0$  V,  $GND = 0.0$  V,  $T_a = -20$  °to  $+75$ °C, unless otherwise specified)

Item	Symbol	Pins	Min	Typ	Max	Unit	Test Condition	Notes
Input high voltage	$V_{IH}$	R5 <sub>1</sub> –RD	$0.7V_{CC}$	—	$V_{CC} + 0.3$	V		
Input low voltage	$V_{IL}$	R5 <sub>1</sub> –RD	-0.3	—	$0.3V_{CC}$	V		
Output high voltage	$V_{OH}$	R6–RB	$V_{CC} - 1.0$	—	—	V	$-I_{OH} = 1.0$ mA, $V_{CC} = 3.5$ to $6.0$ V	
			$V_{CC} - 0.5$	—	—	V	$-I_{OH} = 0.5$ mA, $V_{CC} = 3.5$ to $6.0$ V	
						V	$-I_{OH} = 0.3$ mA	
Output low voltage	$V_{OL}$	R6–RB	—	—	0.4	V	$I_{OL} = 1.6$ mA, $V_{CC} = 3.5$ to $6.0$ V $I_{OL} = 0.4$ mA	
Input/output leakage current	$ I_{IL} $	R5 <sub>1</sub> –RD	—	—	1	$\mu$ A	$V_{in} = 0$ V to $V_{CC}$	1
Pull-up MOS current	$I_p$	R5 <sub>1</sub> –RD	30	80	160	$\mu$ A	$V_{CC} = 5$ V, $V_{in} = 0$ V	2
			10	30	60	$\mu$ A	$V_{CC} = 3$ V, $V_{in} = 0$ V	

Notes: 1. Excluding pull-up MOS current and output buffer current.  
2. Applies to I/O pins selected as with pull-up MOS by mask option.

**Input/Output Characteristics for Open-Drain PMOS Pins** ( $V_{CC} = 3.0$  to  $6.0$  V,  $GND = 0.0$  V,  $T_a = -20$  °to  $+75$ °C, unless otherwise specified)

Item	Symbol	Pins	Min	Typ	Max	Unit	Test Condition	Notes
Input high voltage	$V_{IH}$	D <sub>0</sub> –D <sub>15</sub> , R5 <sub>0</sub> , R0–R4	$0.7V_{CC}$	—	$V_{CC} + 0.3$	V		
Input low voltage	$V_{IL}$	D <sub>0</sub> –D <sub>15</sub> , R5 <sub>0</sub> , R0–R4	-0.3	—	$0.3V_{CC}$	V		
Output high voltage	$V_{OH}$	D <sub>0</sub> –D <sub>15</sub> , R0–R4	$V_{CC} - 3.0$	—	—	V	$-I_{OH} = 15$ mA, $V_{CC} = 4$ V to $6$ V	
			$V_{CC} - 2.0$	—	—	V	$-I_{OH} = 10$ mA, $V_{CC} = 4$ V to $6$ V	
			$V_{CC} - 1.0$	—	—	V	$-I_{OH} = 4$ mA	
Input/output leakage current	$ I_{IL} $	D <sub>0</sub> –D <sub>15</sub> , R5 <sub>0</sub> , R0–R4	—	—	4	$\mu$ A	$V_{in} = 0$ V to $V_{CC}$	1

Notes: 1. Excluding output buffer current.

# HD404719/HD404439/HD4074719

AC Characteristics ( $V_{CC} = 3.0$  to  $6.0$  V,  $GND = 0.0$  V,  $T_a = -20^\circ$  to  $+75^\circ\text{C}$ , unless otherwise specified)

Item	Symbol	Pin(s)	Min	Typ	Max	Unit	Test Condition	Notes
Oscillation frequency (1/4 division)	$f_{OSC}$	OSC <sub>1</sub> , OSC <sub>2</sub>	1.6	4	4.5	MHz	$V_{CC} = 3.5$ to $6.0$ V	
			1.6	2	2.25	MHz		
Oscillation frequency (1/8 division)	$f_{CL}$	CL <sub>1</sub> , CL <sub>2</sub>	—	32.768	—	kHz		
Instruction cycle time	$t_{cyc}$		0.89	1	2.5	$\mu\text{s}$	$V_{CC} = 3.5$ to $6.0$ V	
			1.78	2	2.5	$\mu\text{s}$		
Instruction cycle time	$t_{SUBcyc}$		—	244.14	—	$\mu\text{s}$		6
Oscillation stabilization time (crystal oscillator)	$t_{RC}$	OSC <sub>1</sub> , OSC <sub>2</sub>	—	—	40	ms	$V_{CC} = 3.5$ to $6.0$ V	1
			—	—	60	ms		1
Oscillation stabilization time (ceramic oscillator)	$t_{RC}$	OSC <sub>1</sub> , OSC <sub>2</sub>	—	—	20	ms	$V_{CC} = 3.5$ to $6.0$ V	1
			—	—	60	ms		1
Oscillation stabilization time	$t_{RC}$	CL <sub>1</sub> , CL <sub>2</sub>	—	—	2	s		2
External clock high width	$t_{CPH}$	OSC <sub>1</sub>	92	—	—	ns	$V_{CC} = 3.5$ to $6.0$ V	3
			203	—	—	ns		3
External clock low width	$t_{CPL}$	OSC <sub>1</sub>	92	—	—	ns	$V_{CC} = 3.5$ to $6.0$ V	3
			203	—	—	ns		3
External clock rise time	$t_{CPr}$	OSC <sub>1</sub>	—	—	20	ns	$V_{CC} = 3.5$ to $6.0$ V	3
			—	—	20	ns		3
External clock fall time	$t_{CPl}$	OSC <sub>1</sub>	—	—	20	ns	$V_{CC} = 3.5$ to $6.0$ V	3
			—	—	20	ns		3
INT <sub>0</sub> high width	$t_{I0H}$	INT <sub>0</sub>	2	—	—	$t_{cyc}/t_{SUBcyc}$		4, 6
INT <sub>0</sub> low width	$t_{I0L}$	INT <sub>0</sub>	2	—	—	$t_{cyc}/t_{SUBcyc}$		4, 6
INT high width	$t_{I1H}$	INT <sub>1</sub> –INT <sub>5</sub>	2	—	—	$t_{cyc}$		4
INT low width	$t_{I1L}$	INT <sub>1</sub> –INT <sub>5</sub>	2	—	—	$t_{cyc}$		4

**AC Characteristics ( $V_{CC} = 3.0$  to  $6.0$  V,  $GND = 0.0$  V,  $T_a = -20^\circ$  to  $+75^\circ$ C, unless otherwise specified)  
(cont)**

Item	Symbol	Pin(s)	Min	Typ	Max	Unit	Test Condition	Notes
RESET high width	$t_{RSTH}$	RESET	2	—	—	$t_{cyc}$		5
Input capacitance	$C_{in}$	All pins	—	—	30	pF	$f = 1$ MHz, $V_{in} = 0$ V	
Analog comparator stabilization time	$t_{cstb}$	R6 <sub>0</sub> /COMP	—	—	2	$t_{cyc}$		7

- Notes:
1. The oscillation stabilization time is the period required for the oscillator to stabilize after  $V_{CC}$  reaches 3.0 V (3.5 V if  $V_{CC} = 3.5$  to 6.0 V) at power-on or after RESET input goes high after stop mode is cancelled (figure 68). At power-on and when stop mode is cancelled, RESET must remain high for at least  $t_{RC}$  to ensure the oscillation stabilization time. If using an oscillator, contact the oscillator manufacturer to determine the circuit constants, since the stabilization time depends on the circuit constants and stray capacitances.
  2. The oscillation stabilization time is the period required for the oscillator to stabilize after  $V_{CC}$  reaches 3.0 V at power-on (figure 69). If using a crystal oscillator, contact the manufacturer to determine the circuit constants, since the stabilization time depends on the circuit constants and stray capacitances.
  3. Refer to figure 70.
  4. Refer to figure 71.
  5. Refer to figure 72. The MCU will malfunction if noise conflicts with the falling edge of the RESET signal when releasing from reset state. The reset circuit must be sufficiently evaluated in the application system.
  6. The  $t_{SUBcyc}$  unit applies when the MCU is in watch or subactive mode.  
 $t_{SUBcyc} = 244.14 \mu s$  (32.768-kHz crystal)
  7. The analog comparator stabilization time is the period required for the analog comparator to stabilize and to read correct data after pin R6<sub>0</sub> switches to analog input mode.

# HD404719/HD404439/HD4074719

## Serial Interface Timing Characteristics ( $V_{CC} = 3.0$ to $6.0$ V, $GND = 0.0$ V, $T_a = -20^\circ$ to $+75^\circ\text{C}$ )

Item	Symbol	Plns	Min	Typ	Max	Unit	Test Condition	Notes
Output transmit clock cycle time	$t_{Scyc}$	SCK <sub>1</sub> , SCK <sub>2</sub>	1	—	—	$t_{cyc}$	Load shown in figure 74	1, 2
Output transmit clock high width	$t_{SCKH}$	SCK <sub>1</sub> , SCK <sub>2</sub>	0.4	—	—	$t_{Scyc}$		1, 2
Output transmit clock low width	$t_{SCKL}$	SCK <sub>1</sub> , SCK <sub>2</sub>	0.4	—	—	$t_{Scyc}$		1, 2
Output transmit clock rise time	$t_{SCKr}$	SCK <sub>1</sub> , SCK <sub>2</sub>	—	—	80	ns		1, 2
Output transmit clock fall time	$t_{SCKf}$	SCK <sub>1</sub> , SCK <sub>2</sub>	—	—	80	ns		1, 2
Input transmit clock cycle time	$t_{Scyc}$	SCK <sub>1</sub> , SCK <sub>2</sub>	2	—	—	$t_{cyc}$		1
Input transmit clock high width	$t_{SCKH}$	SCK <sub>1</sub> , SCK <sub>2</sub>	0.4	—	—	$t_{Scyc}$		1
Input transmit clock low width	$t_{SCKL}$	SCK <sub>1</sub> , SCK <sub>2</sub>	0.4	—	—	$t_{Scyc}$		1
Input transmit clock rise time	$t_{SCKr}$	SCK <sub>1</sub> , SCK <sub>2</sub>	—	—	80	ns		1
Input transmit clock fall time	$t_{SCKf}$	SCK <sub>1</sub> , SCK <sub>2</sub>	—	—	80	ns		1
Serial output data delay time	$t_{DSO}$	SO <sub>1</sub> , SO <sub>2</sub>	—	—	600	ns	Load shown in figure 74	1, 2
Serial input data setup time	$t_{SSI}$	SI <sub>1</sub> , SI <sub>2</sub>	200	—	—	ns		1
Serial input data hold time	$t_{HSI}$	SI <sub>1</sub> , SI <sub>2</sub>	400	—	—	ns		1

Notes: 1. Refer to figure 73.  
2. Refer to figure 74.

Serial Interface Timing Characteristics ( $V_{CC} = 3.5$  to  $6.0$  V)

Item	Symbol	Pins	Min	Typ	Max	Unit	Test Condition	Notes
Output transmit clock cycle time	$t_{Scyc}$	$SCK_1$ , $SCK_2$	1	—	—	$t_{cyc}$	Load shown in figure 74	1, 2
Output transmit clock high width	$t_{SCKH}$	$SCK_1$ , $SCK_2$	0.4	—	—	$t_{Scyc}$		1, 2
Output transmit clock low width	$t_{SCKL}$	$SCK_1$ , $SCK_2$	0.4	—	—	$t_{Scyc}$		1, 2
Output transmit clock rise time	$t_{SCKr}$	$SCK_1$ , $SCK_2$	—	—	40	ns		1, 2
Output transmit clock fall time	$t_{SCKf}$	$SCK_1$ , $SCK_2$	—	—	40	ns		1, 2
Input transmit clock cycle time	$t_{Scyc}$	$SCK_1$ , $SCK_2$	2	—	—	$t_{cyc}$		1
Input transmit clock high width	$t_{SCKH}$	$SCK_1$ , $SCK_2$	0.4	—	—	$t_{Scyc}$		1
Input transmit clock low width	$t_{SCKL}$	$SCK_1$ , $SCK_2$	0.4	—	—	$t_{Scyc}$		1
Input transmit clock rise time	$t_{SCKr}$	$SCK_1$ , $SCK_2$	—	—	40	ns		1
Input transmit clock fall time	$t_{SCKf}$	$SCK_1$ , $SCK_2$	—	—	40	ns		1
Serial output data delay time	$t_{DSO}$	$SO_1$ , $SO_2$	—	—	300	ns	Load shown in figure 74	1, 2
Serial input data setup time	$t_{SSI}$	$SI_1$ , $SI_2$	100	—	—	ns		1
Serial input data hold time	$t_{HSI}$	$SI_1$ , $SI_2$	200	—	—	ns		1

Notes: 1. Refer to figure 73.  
2. Refer to figure 74.



**HD4074719 Electrical Characteristics**

**DC Characteristics** ( $V_{CC} = 3.0$  to  $5.5$  V,  $GND = 0.0$  V,  $V_{disp} = V_{CC} - 40$  V to  $V_{CC}$ ,  $T_a = -20^\circ$  to  $+75^\circ$ C, unless otherwise specified)

Item	Symbol	Pin(s)	Min	Typ	Max	Unit	Test Condition	Notes
Input high voltage	$V_{IH}$	RESET, SCK <sub>1</sub> , SCK <sub>2</sub> , INT <sub>0</sub> -INT <sub>5</sub>	$0.85V_{CC}$	—	$V_{CC} + 0.3$	V		
		SI <sub>1</sub> , SI <sub>2</sub>	$0.7V_{CC}$	—	$V_{CC} + 0.3$	V		
		OSC <sub>1</sub>	$V_{CC} - 0.5$	—	$V_{CC} + 0.3$	V	$V_{CC} = 3.5$ to $5.5$ V	
			$V_{CC} - 0.3$	—	$V_{CC} + 0.3$	V		
Input low voltage	$V_{IL}$	RESET, SCK <sub>1</sub> , SCK <sub>2</sub> , INT <sub>0</sub> -INT <sub>5</sub>	-0.3	—	$0.2V_{CC}$	V		
		SI <sub>1</sub> , SI <sub>2</sub>	-0.3	—	$0.3V_{CC}$	V		
		OSC <sub>1</sub>	-0.3	—	0.5	V	$V_{CC} = 3.5$ to $5.5$ V	
			-0.3	—	0.3	V		
Output high voltage	$V_{OH}$	SCK <sub>1</sub> , SCK <sub>2</sub> , SO <sub>1</sub> , SO <sub>2</sub> , BUZZ, TOC, TOD, TOE <sub>1</sub> , TOE <sub>2</sub> , TOG	$V_{CC} - 1.0$	—	—	V	$-I_{OH} = 1.0$ mA, $V_{CC} = 3.5$ to $5.5$ V	
		SCK <sub>1</sub> , SCK <sub>2</sub> , SO <sub>1</sub> , SO <sub>2</sub> , BUZZ, TOC, TOD, TOE <sub>1</sub> , TOE <sub>2</sub> , TOG	$V_{CC} - 0.5$	—	—	V	$-I_{OH} = 0.5$ mA, $V_{CC} = 3.5$ to $5.5$ V	
							V	$-I_{OH} = 0.3$ mA
Output low voltage	$V_{OL}$	SCK <sub>1</sub> , SCK <sub>2</sub> , SO <sub>1</sub> , SO <sub>2</sub> , BUZZ, TOC, TOD, TOE <sub>1</sub> , TOE <sub>2</sub> , TOG	—	—	0.4	V	$I_{OL} = 1.6$ mA, $V_{CC} = 3.5$ to $5.5$ V $I_{OL} = 0.4$ mA	
I/O leakage current	$ I_{IL} $	RESET, SCK <sub>1</sub> , SCK <sub>2</sub> , SI <sub>1</sub> , SI <sub>2</sub> , SO <sub>1</sub> , SO <sub>2</sub> , BUZZ, OSC <sub>1</sub> , TOC, TOD, TOE <sub>1</sub> , TOE <sub>2</sub> , TOG	—	—	1	$\mu$ A	$V_{in} = 0$ V to $V_{CC}$	1

Notes: 1. Excluding output buffer current.

# HD404719/HD404439/HD4074719

**DC Characteristics** ( $V_{CC} = 3.0$  to  $5.5$  V,  $GND = 0.0$  V,  $V_{disp} = V_{CC} - 40$  V to  $V_{CC}$ ,  $T_a = -20^\circ$  to  $+75^\circ$ C, unless otherwise specified) (cont)

Item	Symbol	Pin(s)	Min	Typ	Max	Unit	Test Condition	Notes
Current dissipation in active mode	$I_{CC}$	$V_{CC}$	—	—	8.0	mA	$V_{CC} = 5$ V, $f_{OSC} = 4$ MHz, digital input mode	2, 5
			—	—	4.5	mA	$V_{CC} = 3$ V, $f_{OSC} = 2$ MHz, digital input mode	2, 5
	$I_{CMP}$	$V_{CC}$	—	—	12.0	mA	$V_{CC} = 5$ V, $f_{OSC} = 4$ MHz, analog input mode	3, 5
			—	—	7.0	mA	$V_{CC} = 3$ V, $f_{OSC} = 2$ MHz, analog input mode	3, 5
Current dissipation in standby mode	$I_{SBY}$	$V_{CC}$	—	—	3.0	mA	$V_{CC} = 5$ V, $f_{OSC} = 4$ MHz	4, 5
			—	—	1.5	mA	$V_{CC} = 3$ V, $f_{OSC} = 2$ MHz	4, 5
Current dissipation in subactive mode	$I_{SUB}$	$V_{CC}$	—	—	150	$\mu$ A	$V_{in} (TEST) = V_{CC} - 0.3$ V to $V_{CC}$ $V_{in} (RESET) = 0$ to $0.3$ V, $V_{CC} = 3$ V, 32.768-kHz crystal oscillator	6
Current dissipation in watch mode	$I_{WATCH}$	$V_{CC}$	—	—	15	$\mu$ A	$V_{in} (TEST) = V_{CC} - 0.3$ V to $V_{CC}$ , $V_{in} (RESET) = 0$ to $0.3$ V, $V_{CC} = 3$ V, 32.768-kHz crystal oscillator	6
Current dissipation in stop mode	$I_{STOP}$	$V_{CC}$	—	—	15	$\mu$ A	$V_{in} (TEST) = V_{CC} - 0.3$ V to $V_{CC}$ , $V_{in} (RESET) = 0$ to $0.3$ V, no 32.768-kHz oscillator	6
Watch mode retaining voltage	$V_{WATCH}$	$V_{CC}$	3.5	—	5.5	V	$V_{CC} = 3.5$ to $5.5$ V	
			3.0	—	5.5	V		
Stop mode retaining voltage	$V_{STOP}$	$V_{CC}$	2	—	—	V	No 32.768-kHz oscillator	

# HD404719/HD404439/HD4074719

**DC Characteristics** ( $V_{CC} = 3.0$  to  $5.5$  V,  $GND = 0.0$  V,  $V_{disp} = V_{CC} - 40$  V to  $V_{CC}$ ,  $T_a = -20^\circ$  to  $+75^\circ$  C, unless otherwise specified) (cont)

Item	Symbol	Pin(s)	Min	Typ	Max	Unit	Test Condition	Notes
Input high voltage	$V_{IHA}$	R6 <sub>0</sub> /COMP	$V_{ref} + 0.1$	—	—	V	Analog compare mode	
Input low voltage	$V_{ILA}$	R6 <sub>0</sub> /COMP	—	—	$V_{ref} - 0.1$	V	Analog compare mode	
Range of analog input reference voltage	$V_{ref}$	R6 <sub>1</sub> / $V_{ref}$	0	—	$V_{CC} - 1.2$	V		
Allowable error of internal reference voltage	$V_{OFS}$		-100	—	+100	mV	$V_{OFS} = \text{reference voltage} - V_{ref}$	7

- Notes:
- $I_{CC}$  is the source current when no I/O current is flowing while the MCU is in reset state.  
 Test conditions: MCU: Reset  
 Pins: RESET, TEST at  $V_{CC}$   
 R5<sub>1</sub>–RD at  $V_{CC}$   
 D<sub>0</sub>–D<sub>15</sub>, R0–R4, R5<sub>0</sub> at  $V_{disp}$
  - $I_{CMP}$  is the source current when no I/O current is flowing while the R6<sub>0</sub>/COMP pin is in analog input mode.  
 Test conditions: R6<sub>0</sub>/COMP, R6<sub>1</sub>/ $V_{ref}$  at GND
  - $I_{SBY}$  is the source current when no I/O current is flowing while the MCU timer is in operation.  
 Test conditions: MCU: I/O same as at reset  
 Standby mode  
 Pins: RESET at GND  
 TEST at  $V_{CC}$   
 R5<sub>1</sub>–RD at  $V_{CC}$   
 D<sub>0</sub>–D<sub>15</sub>, R0–R4, R5<sub>0</sub> at  $V_{disp}$
  - Power dissipation, while the MCU is operating or in standby mode, is in proportion to  $f_{OSC}$ . The value of the dissipation current when  $f_{OSC} = \chi$  MHz is given by the following equation:  
 Maximum value ( $f_{OSC} = \chi$  MHz) =  $\chi/4 \times$  maximum value ( $f_{OSC} = 4$  MHz)
  - The source current when no I/O current is flowing.  
 Test conditions: Pins: R5<sub>1</sub>–RD at  $V_{CC}$   
 D<sub>0</sub>–D<sub>15</sub>, R0–R4, R5<sub>0</sub> at  $V_{disp}$
  - The reference voltage is the expected internal  $V_{ref}$  voltage selected by the compare control register (CCR).  
 Example: when CCR = \$9, reference voltage is  $2/11 \times V_{CC}$ .

# HD404719/HD404439/HD4074719

**A/D Converter ( $V_{CC} = 3.0$  to  $5.5$  V,  $AGND = GND$ ,  $T_a = -20^\circ$  to  $+75^\circ\text{C}$ , unless otherwise specified)**

Item	Symbol	Pin(s)	Min	Typ	Max	Unit	Test Condition	Notes
Analog supply voltage	$AV_{CC}$	$AV_{CC}$	$V_{CC} - 0.3$	$V_{CC}$	$V_{CC} + 0.3$	V		
Analog input voltage	$AV_{in}$	$AN_0$ – $AN_7$	AGND	—	$AV_{CC}$	V		
Current between $AV_{CC}$ and AGND	$AI_{CC}$	$AV_{CC}$	—	—	150	$\mu\text{A}$	$AV_{CC} = 5$ V, $V_{in}(\text{RESET}) = 0$ to $0.3$ V, $V_{in}(\text{TEST}) =$ $V_{CC} - 0.3$ V to $V_{CC}$	
	$AI_{\text{STOP}}$	$AV_{CC}$	—	—	15	$\mu\text{A}$	$V_{in}(\text{RESET}) = 0$ to $0.3$ V, $V_{in}(\text{TEST}) =$ $V_{CC} - 0.3$ V to $V_{CC}$ , stop mode, no 32.768-kHz oscillator	
Analog input capacitance	$C_{ain}$	$AN_0$ – $AN_7$	—	—	30	pF		
Resolution			—	—	8	Bit		
Number of input channels			0	—	8	Channel		
Absolute error			—	—	$\pm 2.5$	LSB	$T_a = 25^\circ\text{C}$ , $AV_{CC} = 5$ V	

# HD404719/HD404439/HD4074719

**Input/Output Characteristics for Standard Pins** ( $V_{CC} = 3.0$  to  $5.5$  V,  $GND = 0.0$  V,  $V_{disp} = V_{CC} - 40$  V to  $V_{CC}$ ,  $T_a = -20^\circ$  to  $+75^\circ$ C, unless otherwise specified)

Item	Symbol	Pins	Min	Typ	Max	Unit	Test Condition	Notes
Input high voltage	$V_{IH}$	R5 <sub>1</sub> -RD	$0.7V_{CC}$	—	$V_{CC} + 0.3$	V		
Input low voltage	$V_{IL}$	R5 <sub>1</sub> -RD	-0.3	—	$0.3V_{CC}$	V		
Output high voltage	$V_{OH}$	R6-RB	$V_{CC} - 1.0$	—	—	V	$-I_{OH} = 1.0$ mA, $V_{CC} = 3.5$ to $5.5$ V	
			$V_{CC} - 0.5$	—	—	V	$-I_{OH} = 0.5$ mA, $V_{CC} = 3.5$ to $5.5$ V	
						V	$-I_{OH} = 0.3$ mA	
Output low voltage	$V_{OL}$	R6-RB	—	—	0.4	V	$I_{OL} = 1.6$ mA, $V_{CC} = 3.5$ to $5.5$ V	
Input/output leakage current	$ I_{IL} $	R6-RD	—	—	1	$\mu$ A	$V_{in} = 0$ V to $V_{CC}$	1
		R5 <sub>1</sub> , R5 <sub>3</sub>						
		R5 <sub>2</sub>			20			

Notes: 1. Excluding output buffer current.

**Input/Output Characteristics for High-Voltage Pins** ( $V_{CC} = 3.0$  to  $5.5$  V,  $GND = 0.0$  V,  $V_{disp} = V_{CC} - 40$  V to  $V_{CC}$ ,  $T_a = -20^\circ$  to  $+75^\circ$ C, unless otherwise specified)

Item	Symbol	Pins	Min	Typ	Max	Unit	Test Condition	Notes
Input high voltage	$V_{IH}$	D <sub>0</sub> -D <sub>15</sub> , R5 <sub>0</sub> , R0-R4	$0.7V_{CC}$	—	$V_{CC} + 0.3$	V		
Input low voltage	$V_{IL}$	D <sub>0</sub> -D <sub>15</sub> , R5 <sub>0</sub> , R0-R4	$V_{CC} - 40$	—	$0.3V_{CC}$	V		
Output high voltage	$V_{OH}$	D <sub>0</sub> -D <sub>15</sub> , R0-R4	$V_{CC} - 3.0$	—	—	V	$-I_{OH} = 15$ mA, $V_{CC} = 4.0$ to $5.5$ V	
			$V_{CC} - 2.0$	—	—	V	$-I_{OH} = 10$ mA, $V_{CC} = 4.0$ to $5.5$ V	
			$V_{CC} - 1.0$	—	—	V	$-I_{OH} = 4$ mA	
Output low voltage	$V_{OL}$	D <sub>0</sub> -D <sub>15</sub> , R0-R4	—	—	$V_{CC} - 37$	V	150 k $\Omega$ at $V_{CC} - 40$ V	
Input/output leakage current	$ I_{IL} $	D <sub>0</sub> -D <sub>15</sub> , R5 <sub>0</sub> , R0-R4	—	—	20	$\mu$ A	$V_{in} = V_{CC} - 40$ V to $V_{CC}$	1

Notes: 1. Excluding output buffer current.

# HD404719/HD404439/HD4074719

**AC Characteristics** ( $V_{CC} = 3.0$  to  $5.5$  V,  $GND = 0.0$  V,  $V_{disp} = V_{CC} - 40$  V to  $V_{CC}$ ,  $T_a = -20^\circ$  to  $+75^\circ$ C, unless otherwise specified)

Item	Symbol	Pin(s)	Min	Typ	Max	Unit	Test Condition	Notes
Oscillation frequency (1/4 division)	$f_{OSC}$	OSC <sub>1</sub> , OSC <sub>2</sub>	1.6	4	4.5	MHz	$V_{CC} = 3.5$ to $5.5$ V	
			1.6	2	2.25	MHz		
Oscillation frequency (1/8 division)	$f_{CL}$	CL <sub>1</sub> , CL <sub>2</sub>	—	32.768	—	kHz		
Instruction cycle time	$t_{cyc}$		0.89	1	2.5	$\mu$ s	$V_{CC} = 3.5$ to $5.5$ V	
			1.78	2	2.5	$\mu$ s		
Instruction cycle time	$t_{SUBcyc}$		—	244.14	—	$\mu$ s		7
Oscillation stabilization time (crystal oscillator)	$t_{RC}$	OSC <sub>1</sub> , OSC <sub>2</sub>	—	—	40	ms	$V_{CC} = 3.5$ to $5.5$ V	1
			—	—	60	ms		1
Oscillation stabilization time (ceramic oscillator)	$t_{RC}$	OSC <sub>1</sub> , OSC <sub>2</sub>	—	—	20	ms	$V_{CC} = 3.5$ to $5.5$ V	1
			—	—	60	ms		1
Oscillation stabilization time	$t_{RC}$	CL <sub>1</sub> , CL <sub>2</sub>	—	—	2	s		2
External clock high width	$t_{CPH}$	OSC <sub>1</sub>	92	—	—	ns	$V_{CC} = 3.5$ to $5.5$ V	3
			203	—	—	ns		3
External clock low width	$t_{CPL}$	OSC <sub>1</sub>	92	—	—	ns	$V_{CC} = 3.5$ to $5.5$ V	3
			203	—	—	ns		3
External clock rise time	$t_{CPr}$	OSC <sub>1</sub>	—	—	20	ns	$V_{CC} = 3.5$ to $5.5$ V	3
			—	—	20	ns		3
External clock fall time	$t_{CPf}$	OSC <sub>1</sub>	—	—	20	ns	$V_{CC} = 3.5$ to $5.5$ V	3
			—	—	20	ns		3
INT <sub>0</sub> high width	$t_{IOH}$	INT <sub>0</sub>	2	—	—	$t_{cyc}/t_{SUBcyc}$		4, 6
INT <sub>0</sub> low width	$t_{IOL}$	INT <sub>0</sub>	2	—	—	$t_{cyc}/t_{SUBcyc}$		4, 6
INT high width	$t_{I1H}$	INT <sub>1</sub> –INT <sub>5</sub>	2	—	—	$t_{cyc}$		4
INT low width	$t_{I1L}$	INT <sub>1</sub> –INT <sub>5</sub>	2	—	—	$t_{cyc}$		4

Refer to notes on the next page.

# HD404719/HD404439/HD4074719

**AC Characteristics** ( $V_{CC} = 3.0$  to  $5.5$  V,  $GND = 0.0$  V,  $V_{disp} = V_{CC} - 40$  V to  $V_{CC}$ ,  $T_a = -20^\circ$  to  $+75^\circ$ C, unless otherwise specified) (cont)

Item	Symbol	Pin(s)	Min	Typ	Max	Unit	Test Condition	Notes
RESET high width	$t_{RSTH}$	RESET	2	—	—	$t_{cyc}$		5
Input capacitance	$C_{in}$	R5 <sub>2</sub>	—	—	180	pF	$f = 1$ MHz, $V_{in} = 0$ V	
		Others	—	—	30	pF		
Analog comparator stabilizer time	$t_{cstb}$	R6 <sub>0</sub> /COMP	—	—	2	$t_{cyc}$		7

- Notes:
1. The oscillation stabilization time is the period required for the oscillator to stabilize after  $V_{CC}$  reaches 3.0 V (3.5 V if  $V_{CC} = 3.5$  to  $5.5$  V) at power-on or after RESET input goes high after stop mode is cancelled (figure 68). At power-on and when stop mode is cancelled, RESET must remain high for at least  $t_{RC}$  to ensure the oscillation stabilization time. If using an oscillator, contact the oscillator manufacturer to determine the circuit constants, since the stabilization time depends on the circuit constants and stray capacitances.
  2. The oscillation stabilization time is the period required for the oscillator to stabilize after  $V_{CC}$  reaches 3.0 V at power-on (figure 69). If using a crystal oscillator, contact the manufacturer to determine the circuit constants, since the stabilization time depends on the circuit constants and stray capacitances.
  3. Refer to figure 70.
  4. Refer to figure 71.
  5. Refer to figure 72. The MCU will malfunction if noise conflicts with the falling edge of the RESET signal when releasing from reset state. The reset circuit must be sufficiently evaluated in the application system.
  6. The  $t_{SUBcyc}$  unit applies when the MCU is in watch or subactive mode.  
 $t_{SUBcyc} = 244.14 \mu s$  (32.768-kHz crystal)
  7. The analog comparator stabilizer time is the period required for the analog comparator to stabilize and to read correct data after pin R6<sub>0</sub> switches to analog input mode.

## HD404719/HD404439/HD4074719

**Serial Interface Timing Characteristics** ( $V_{CC} = 3.0$  to  $5.5$  V,  $GND = 0.0$  V,  $V_{disp} = V_{CC} - 40$  V to  $V_{CC}$ ,  $T_a = -20^\circ$  to  $+75^\circ\text{C}$ )

Item	Symbol	Pins	Min	Typ	Max	Unit	Test Condition	Notes
Output transmit clock cycle time	$t_{Scyc}$	SCK <sub>1</sub> , SCK <sub>2</sub>	1	—	—	$t_{cyc}$	Load shown in figure 74	1, 2
Output transmit clock high width	$t_{SCKH}$	SCK <sub>1</sub> , SCK <sub>2</sub>	0.4	—	—	$t_{Scyc}$		1, 2
Output transmit clock low width	$t_{SCKL}$	SCK <sub>1</sub> , SCK <sub>2</sub>	0.4	—	—	$t_{Scyc}$		1, 2
Output transmit clock rise time	$t_{SCKr}$	SCK <sub>1</sub> , SCK <sub>2</sub>	—	—	80	ns		1, 2
Output transmit clock fall time	$t_{SCKf}$	SCK <sub>1</sub> , SCK <sub>2</sub>	—	—	80	ns		1, 2
Input transmit clock cycle time	$t_{Scyc}$	SCK <sub>1</sub> , SCK <sub>2</sub>	2	—	—	$t_{cyc}$		1
Input transmit clock high width	$t_{SCKH}$	SCK <sub>1</sub> , SCK <sub>2</sub>	0.4	—	—	$t_{Scyc}$		1
Input transmit clock low width	$t_{SCKL}$	SCK <sub>1</sub> , SCK <sub>2</sub>	0.4	—	—	$t_{Scyc}$		1
Input transmit clock rise time	$t_{SCKr}$	SCK <sub>1</sub> , SCK <sub>2</sub>	—	—	80	ns		1
Input transmit clock fall time	$t_{SCKf}$	SCK <sub>1</sub> , SCK <sub>2</sub>	—	—	80	ns		1
Serial output data delay time	$t_{DSO}$	SO <sub>1</sub> , SO <sub>2</sub>	—	—	600	ns	Load shown in figure 74	1, 2
Serial input data setup time	$t_{SSI}$	SI <sub>1</sub> , SI <sub>2</sub>	200	—	—	ns		1
Serial input data hold time	$t_{HSI}$	SI <sub>1</sub> , SI <sub>2</sub>	400	—	—	ns		1

Notes: 1. Refer to figure 73.  
2. Refer to figure 74.



**Serial Interface Timing Characteristics (V<sub>CC</sub> = 3.5 to 5.5 V)**

Item	Symbol	Pins	Min	Typ	Max	Unit	Test Condition	Notes
Output transmit clock cycle time	t <sub>Scyc</sub>	SCK <sub>1</sub> , SCK <sub>2</sub>	1	—	—	t <sub>cyc</sub>	Load shown in figure 74	1, 2
Output transmit clock high width	t <sub>SCKH</sub>	SCK <sub>1</sub> , SCK <sub>2</sub>	0.4	—	—	t <sub>Scyc</sub>		1, 2
Output transmit clock low width	t <sub>SCKL</sub>	SCK <sub>1</sub> , SCK <sub>2</sub>	0.4	—	—	t <sub>Scyc</sub>		1, 2
Output transmit clock rise time	t <sub>SCKr</sub>	SCK <sub>1</sub> , SCK <sub>2</sub>	—	—	40	ns		1, 2
Output transmit clock fall time	t <sub>SCKf</sub>	SCK <sub>1</sub> , SCK <sub>2</sub>	—	—	40	ns		1, 2
Input transmit clock cycle time	t <sub>Scyc</sub>	SCK <sub>1</sub> , SCK <sub>2</sub>	2	—	—	t <sub>cyc</sub>		1
Input transmit clock high width	t <sub>SCKH</sub>	SCK <sub>1</sub> , SCK <sub>2</sub>	0.4	—	—	t <sub>Scyc</sub>		1
Input transmit clock low width	t <sub>SCKL</sub>	SCK <sub>1</sub> , SCK <sub>2</sub>	0.4	—	—	t <sub>Scyc</sub>		1
Input transmit clock rise time	t <sub>SCKr</sub>	SCK <sub>1</sub> , SCK <sub>2</sub>	—	—	40	ns		1
Input transmit clock fall time	t <sub>SCKf</sub>	SCK <sub>1</sub> , SCK <sub>2</sub>	—	—	40	ns		1
Serial output data delay time	t <sub>DSO</sub>	SO <sub>1</sub> , SO <sub>2</sub>	—	—	300	ns	Load shown in figure 74	1, 2
Serial input data setup time	t <sub>SSI</sub>	SI <sub>1</sub> , SI <sub>2</sub>	100	—	—	ns		1
Serial input data hold time	t <sub>HSI</sub>	SI <sub>1</sub> , SI <sub>2</sub>	200	—	—	ns		1

Notes: 1. Refer to figure 73.  
2. Refer to figure 74.

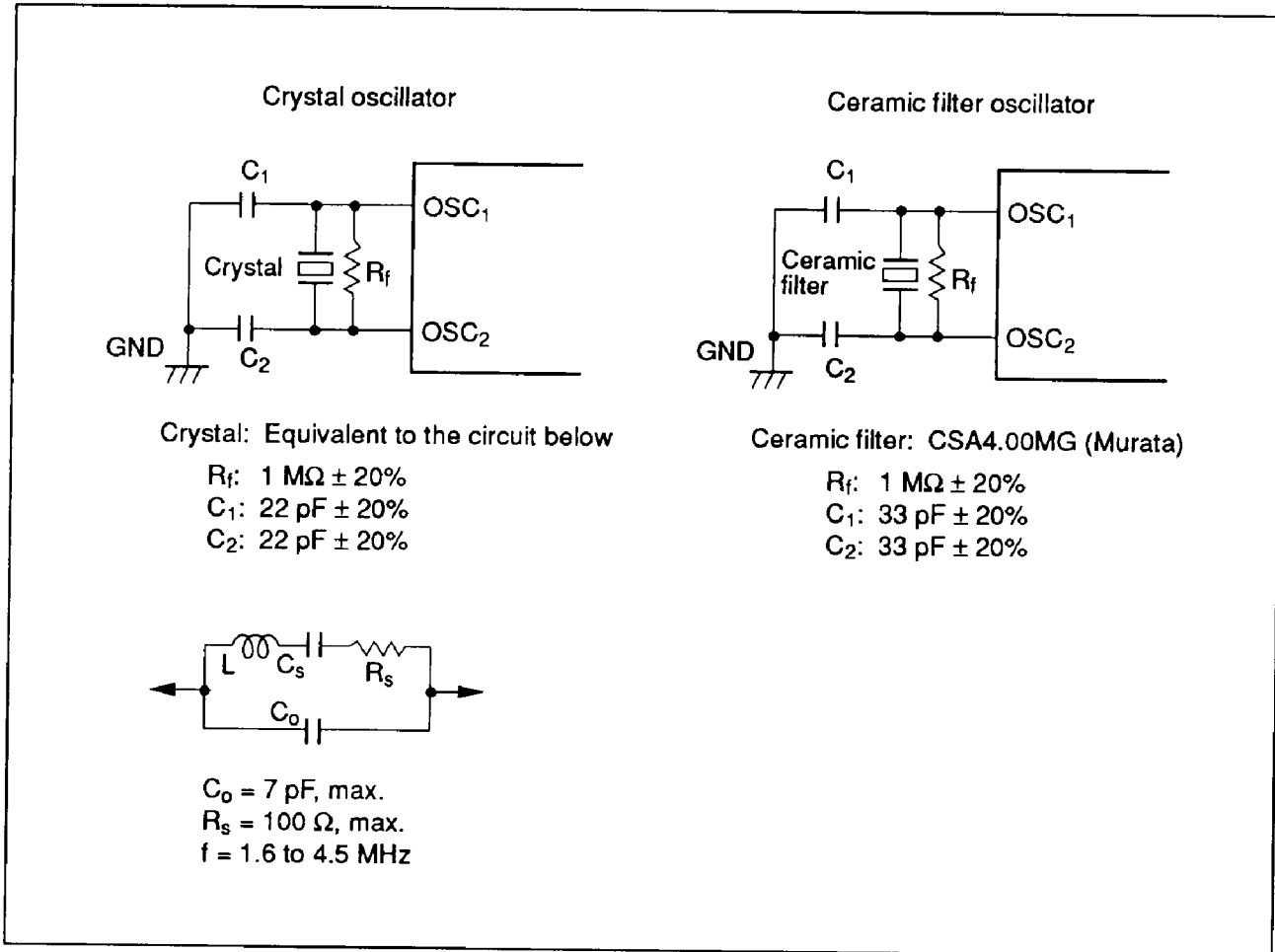

Figure 68 Oscillation Circuits (1)

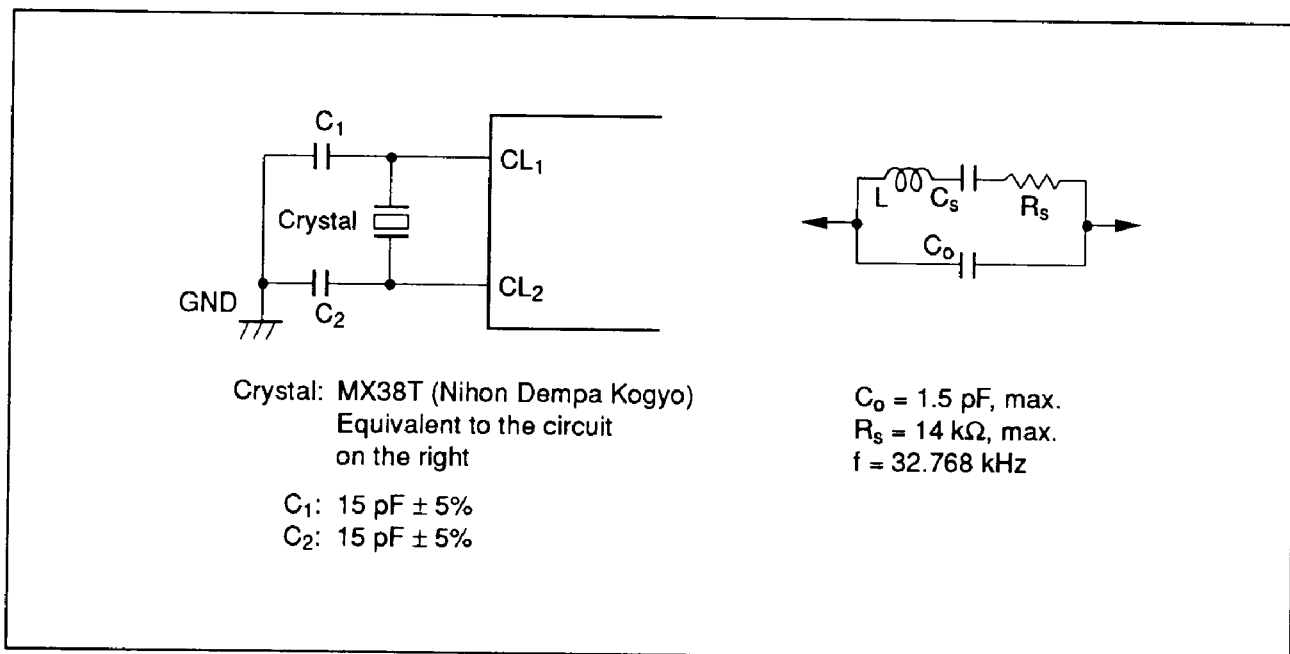

Figure 69 Oscillation Circuits (2)

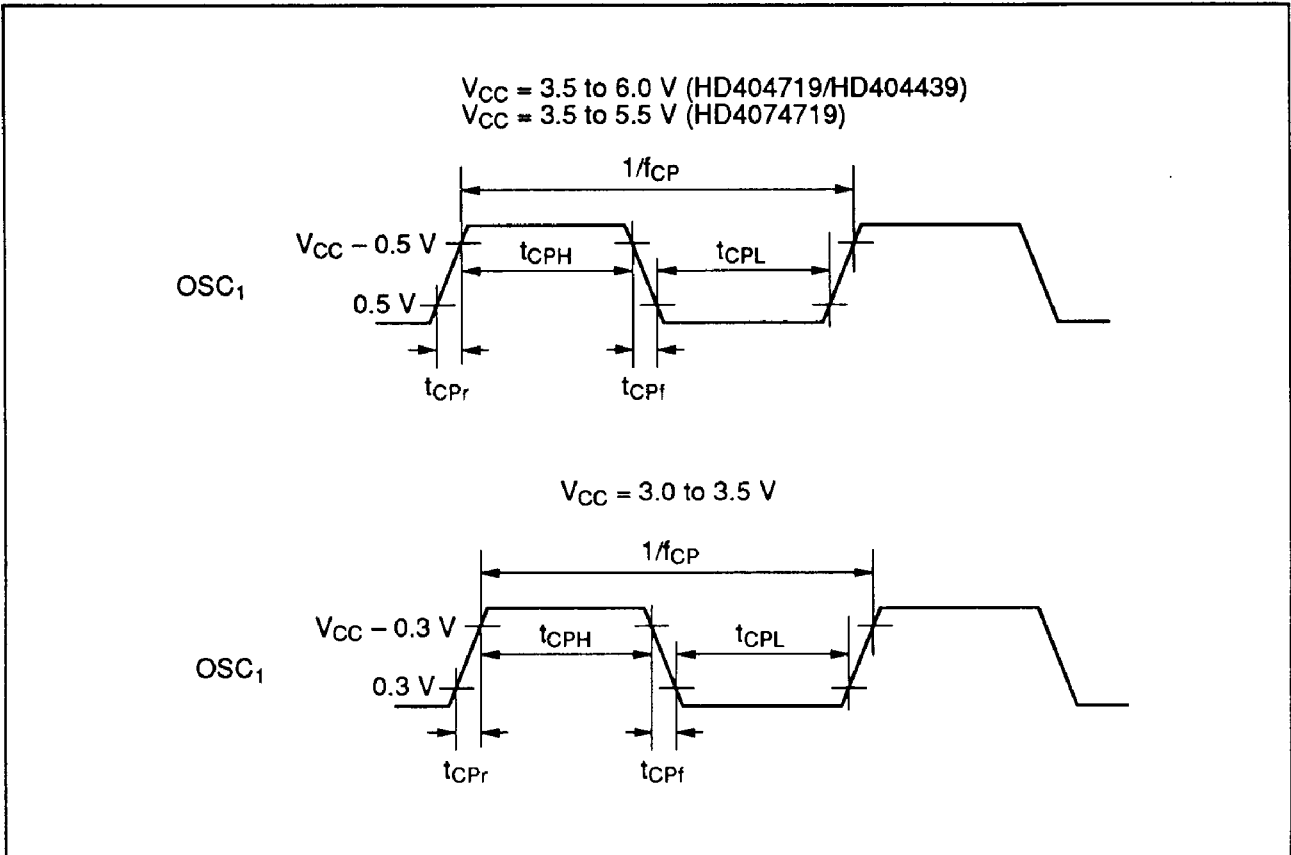

Figure 70 Oscillator Waveforms

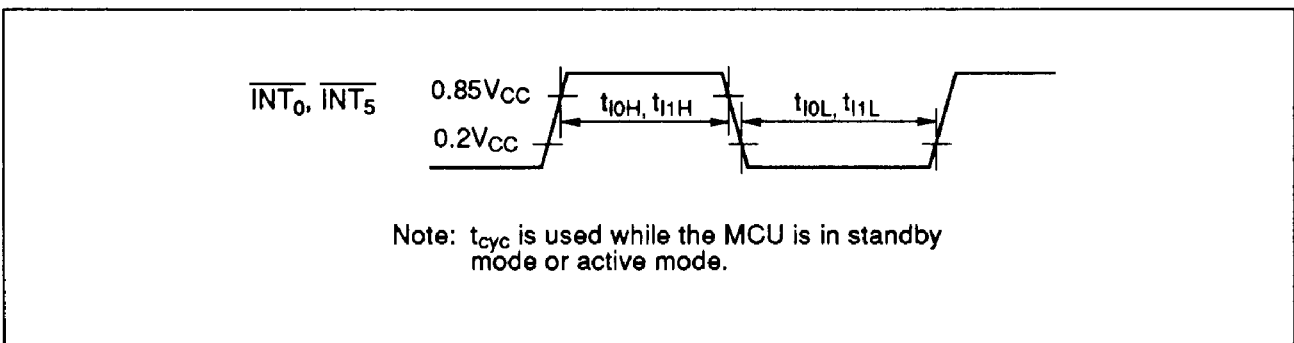

Figure 71 Interrupt Timing

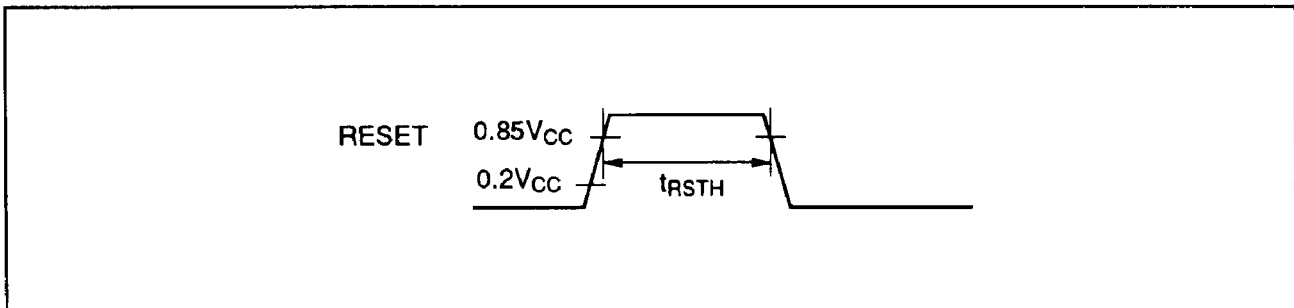

Figure 72 Reset Timing

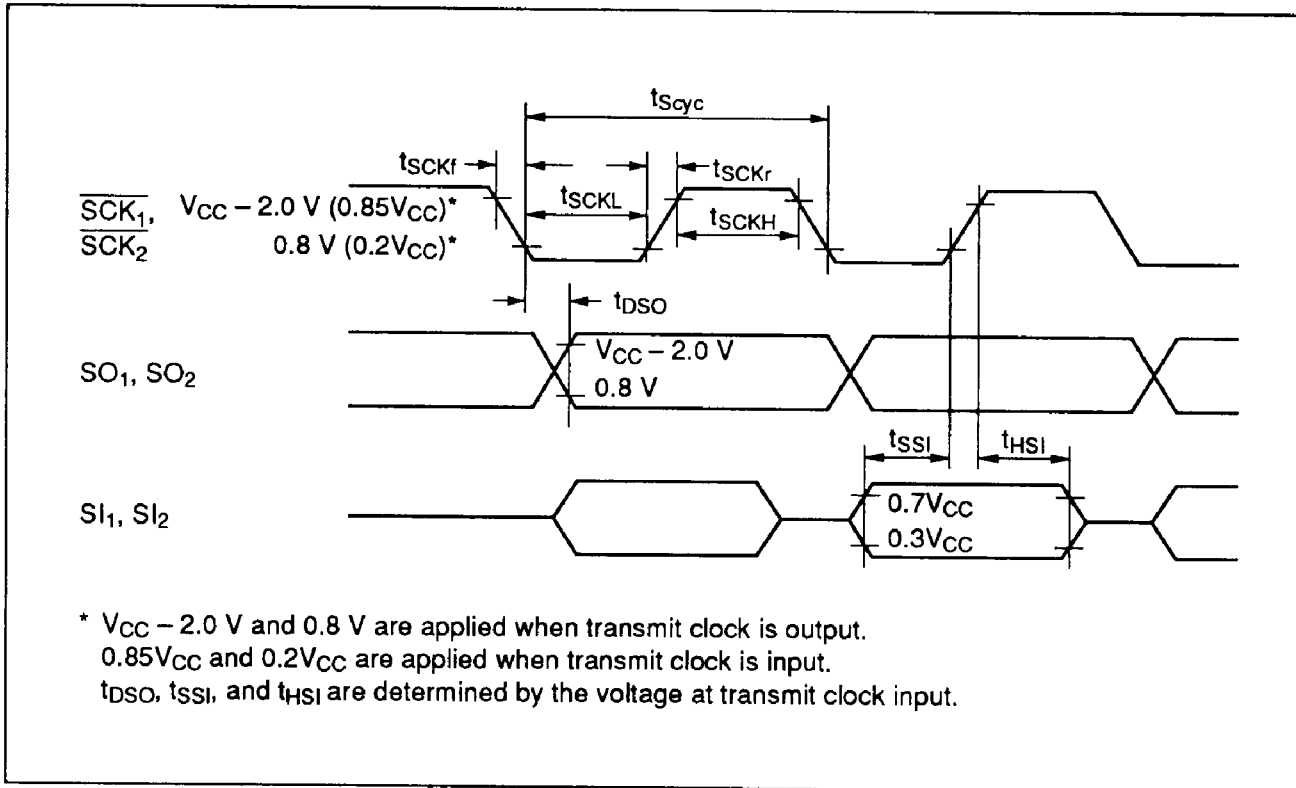

Figure 73 Serial Interface Timing

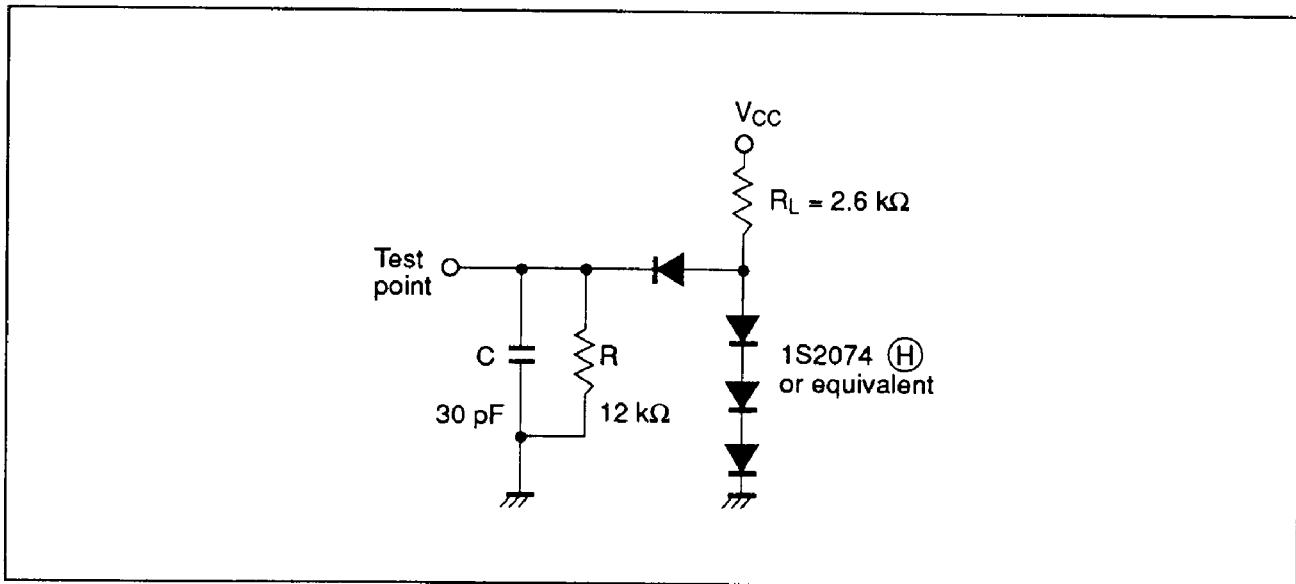

Figure 74 Load Circuit for Timing Measurement

# HD404719/HD404439/HD4074719

## HD404719 Option List

\* Please check off applicable items by , , , or  within .

### 1. Package and Storage Tray Types

<input type="checkbox"/> FP-80A	<input type="checkbox"/> Hard tray
<input type="checkbox"/> FP-80B	<input type="checkbox"/> Soft tray

For other tray types, contact Hitachi's business department.

### 2. Optional Functions

<input type="checkbox"/> 32-kHz CPU operation
<input type="checkbox"/> No 32-kHz CPU operation with clock time-base
<input type="checkbox"/> No 32-kHz CPU operation, no clock time-base

### 3. ZTAT™ Compatibility

<input type="checkbox"/> I/O circuit compatibility with the HD4074719
<input type="checkbox"/> No I/O circuit compatibility with the HD4074719

Note: ZTAT™ compatibility is enabled only when all pins have C- or D-type circuits. In this case do not use checklist 5.

### 5. I/O Options (shaded options are not available)

Pin name	I/O option					Pin name	I/O	I/O option					Pin name	I/O	I/O option					
	B	C	D	E	B			C	D	E	B	C			D	E				
D <sub>0</sub>	I/O					R4	High-voltage pins	R4 <sub>0</sub>	I/O					RC <sub>*2</sub>	RC <sub>2</sub>	I				
D <sub>1</sub>	I/O							R4 <sub>1</sub>	I/O									RC <sub>3</sub>	I	
D <sub>2</sub>	I/O					R5	High-voltage pins	R4 <sub>2</sub>	I/O					RD <sub>*2</sub>	RD <sub>0</sub>	I				
D <sub>3</sub>	I/O							R4 <sub>3</sub>	I/O									RD <sub>1</sub>	I	
D <sub>4</sub>	I/O					R6 <sub>*1</sub>	High-voltage pins	R5 <sub>0</sub>	I					RD <sub>2</sub>	I					
D <sub>5</sub>	I/O							R5 <sub>1</sub>	I								RD <sub>3</sub>	I		
D <sub>6</sub>	I/O					R7	High-voltage pins	R5 <sub>2</sub>	I					RD <sub>3</sub>	I					
D <sub>7</sub>	I/O							R5 <sub>3</sub>	I											
D <sub>8</sub>	I/O					R8	Standard pins	R6 <sub>0</sub>	I/O											
D <sub>9</sub>	I/O							R6 <sub>1</sub>	I/O											
D <sub>10</sub>	I/O					R9	Standard pins	R6 <sub>2</sub>	I/O											
D <sub>11</sub>	I/O							R6 <sub>3</sub>	I/O											
D <sub>12</sub>	I/O					RA	Standard pins	R7 <sub>0</sub>	I/O											
D <sub>13</sub>	I/O							R7 <sub>1</sub>	I/O											
D <sub>14</sub>	I/O					RB	Standard pins	R7 <sub>2</sub>	I/O											
D <sub>15</sub>	I/O							R7 <sub>3</sub>	I/O											
R0	R0 <sub>0</sub>	I/O				RC <sub>*2</sub>	Standard pins	R8 <sub>0</sub>	I/O											
	R0 <sub>1</sub>	I/O						R8 <sub>1</sub>	I/O											
	R0 <sub>2</sub>	I/O						R8 <sub>2</sub>	I/O											
	R0 <sub>3</sub>	I/O						R8 <sub>3</sub>	I/O											
R1	R1 <sub>0</sub>	I/O				RC <sub>*2</sub>	Standard pins	R9 <sub>0</sub>	I/O											
	R1 <sub>1</sub>	I/O						R9 <sub>1</sub>	I/O											
	R1 <sub>2</sub>	I/O						R9 <sub>2</sub>	I/O											
	R1 <sub>3</sub>	I/O						R9 <sub>3</sub>	I/O											
R2	R2 <sub>0</sub>	I/O				RC <sub>*2</sub>	Standard pins	RA <sub>0</sub>	I/O											
	R2 <sub>1</sub>	I/O						RA <sub>1</sub>	I/O											
	R2 <sub>2</sub>	I/O						RA <sub>2</sub>	I/O											
	R2 <sub>3</sub>	I/O						RA <sub>3</sub>	I/O											
R3	R3 <sub>0</sub>	I/O				RC <sub>*2</sub>	Standard pins	RB <sub>0</sub>	I/O											
	R3 <sub>1</sub>	I/O						RB <sub>1</sub>	I/O											
	R3 <sub>2</sub>	I/O						RC <sub>0</sub>	I											
	R3 <sub>3</sub>	I/O						RC <sub>1</sub>	I											

Order date	
Customer name	
Department	
Name	
ROM code	
LSI type	HD404719

### 4. ROM Media

<input type="checkbox"/> EPROM: Emulator type
<input type="checkbox"/> HD4074719

Check the I/O option required.

- B: With pull-up MOS
- C: Without pull-up MOS
- D: Without pull-down MOS
- E: With pull-down MOS

### 6. R5<sub>0</sub>/V<sub>disp</sub>

<input type="checkbox"/> R5 <sub>0</sub> : Without pull-down MOS (D)
<input type="checkbox"/> V <sub>disp</sub>

Note: R5<sub>0</sub>/V<sub>disp</sub> must be selected as the V<sub>disp</sub> pin, except when all high-voltage pins are option D.

### 7. OSC<sub>1</sub> and OSC<sub>2</sub> Oscillator

<input type="checkbox"/> Ceramic oscillator	f =	MHz
<input type="checkbox"/> Crystal	f =	MHz
<input type="checkbox"/> External clock	f =	MHz

### 8. CL<sub>1</sub> and CL<sub>2</sub> Oscillator

<input type="checkbox"/> Not used	—
<input type="checkbox"/> Crystal	f = 32.768 kHz

Notes: \*1. When using the comparator, do not select B-type circuits for the R6<sub>0</sub>/COMP and R6<sub>1</sub>/V<sub>ref</sub> pins.  
\*2. When using the RC and RD pins as analog input pins, do not select B-type circuits.

**HD404439 Option List**

\* Please check off applicable items by , x, or  within .

**1. Package and Storage Tray Types**

<input type="checkbox"/> FP-80A	<input type="checkbox"/> Hard tray
<input type="checkbox"/> FP-80B	<input type="checkbox"/> Soft tray

For other tray types, contact Hitachi's business department.

**2. Optional Functions**

<input type="checkbox"/> 32-kHz CPU operation
<input type="checkbox"/> No 32-kHz CPU operation with clock time-base
<input type="checkbox"/> No 32-kHz CPU operation, no clock time-base

**3. ZTAT™ Compatibility**

<input type="checkbox"/> I/O circuit compatibility with the HD4074719
<input type="checkbox"/> No I/O circuit compatibility with the HD4074719

Note: ZTAT™ compatibility is enabled only when all pins have C- or D-type circuits. In this case do not use checklist 5.

**5. I/O Options (shaded options are not available)**

Pin name	I/O	I/O option				Pin name	I/O	I/O option				Pin name	I/O	I/O option						
		B	C	D	E			B	C	D	E			B	C	D	E			
D <sub>0</sub>	I/O					R4	R4 <sub>0</sub>	I/O					RC *2	RC <sub>2</sub>	I					
D <sub>1</sub>	I/O						R4 <sub>1</sub>	I/O							RC <sub>3</sub>	I				
D <sub>2</sub>	I/O						R4 <sub>2</sub>	I/O							RD <sub>0</sub>	I				
D <sub>3</sub>	I/O						R4 <sub>3</sub>	I/O							RD <sub>1</sub>	I				
D <sub>4</sub>	I/O					R5	R5 <sub>0</sub>	I					RD *2	RD <sub>2</sub>	I					
D <sub>5</sub>	I/O						R5 <sub>1</sub>	I							RD <sub>3</sub>	I				
D <sub>6</sub>	I/O						R5 <sub>2</sub>	I												
D <sub>7</sub>	I/O					R6 *1	R6 <sub>0</sub>	I/O												
D <sub>8</sub>	I/O						R6 <sub>1</sub>	I/O												
D <sub>9</sub>	I/O						R6 <sub>2</sub>	I/O												
D <sub>10</sub>	I/O						R6 <sub>3</sub>	I/O												
D <sub>11</sub>	I/O					R7	R7 <sub>0</sub>	I/O												
D <sub>12</sub>	I/O						R7 <sub>1</sub>	I/O												
D <sub>13</sub>	I/O						R7 <sub>2</sub>	I/O												
D <sub>14</sub>	I/O						R7 <sub>3</sub>	I/O												
D <sub>15</sub>	I/O					R8	R8 <sub>0</sub>	I/O												
R0	R0 <sub>0</sub>	I/O					R8 <sub>1</sub>	I/O												
	R0 <sub>1</sub>	I/O					R8 <sub>2</sub>	I/O												
	R0 <sub>2</sub>	I/O					R8 <sub>3</sub>	I/O												
R1	R1 <sub>0</sub>	I/O				R9	R9 <sub>0</sub>	I/O												
	R1 <sub>1</sub>	I/O					R9 <sub>1</sub>	I/O												
	R1 <sub>2</sub>	I/O					R9 <sub>2</sub>	I/O												
	R1 <sub>3</sub>	I/O					R9 <sub>3</sub>	I/O												
R2	R2 <sub>0</sub>	I/O				RA	RA <sub>0</sub>	I/O												
	R2 <sub>1</sub>	I/O					RA <sub>1</sub>	I/O												
	R2 <sub>2</sub>	I/O					RA <sub>2</sub>	I/O												
	R2 <sub>3</sub>	I/O					RA <sub>3</sub>	I/O												
R3	R3 <sub>0</sub>	I/O				RB	RB <sub>0</sub>	I/O												
	R3 <sub>1</sub>	I/O					RB <sub>1</sub>	I/O												
	R3 <sub>2</sub>	I/O					RC *2	RC <sub>0</sub>	I											
	R3 <sub>3</sub>	I/O						RC <sub>1</sub>	I											

Notes: \*1. When using the comparator, do not select B-type circuits for the R6<sub>0</sub>/COMP and R6<sub>1</sub>/V<sub>ref</sub> pins.  
 \*2. When using the RC and RD pins as analog input pins, do not select B-type circuits.

Order date	
Customer name	
Department	
Name	
ROM code	
LSI type	HD404439

**4. ROM Media**

<input type="checkbox"/> EPROM: Emulator type
<input type="checkbox"/> HD4074719

Check the I/O option required.  
 B: With pull-up MOS  
 C: Without pull-up MOS  
 D: Without pull-down MOS  
 E: With pull-down MOS

**6. OSC<sub>1</sub> and OSC<sub>2</sub> Oscillator**

<input type="checkbox"/> Ceramic oscillator	f =	MHz
<input type="checkbox"/> Crystal	f =	MHz
<input type="checkbox"/> External clock	f =	MHz

**7. CL<sub>1</sub> and CL<sub>2</sub> Oscillator**

<input type="checkbox"/> Not used	—
<input type="checkbox"/> Crystal	f = 32.768 kHz