

HD63701X0, HD637A01X0, HD637B01X0

(Limiting Supplies. For Development Only.)

The HD63701X0 is a high performance 8-bit CMOS single chip micro-computer unit (MCU) which, including 4k bytes of EPROM, is object code compatible with the HD6301X0.

The HD63701X0 contains 4k bytes of EPROM, 192 bytes of RAM, serial communication interface and 53 parallel I/O pins in addition to CPU. It includes functions of halt, memory ready, low speed access and releasing external bus for system expansion.

The HD 63701X0 is available in a hermetically sealed 64-pin shrunk ceramic package which includes a glass window that allows for programming and EPROM erasure in the same way as 2732A type EPROM.

■ FEATURES

- Instruction Set Compatible with the HD6301X0 and 6801
- 4k Bytes of EPROM (compatible with 2732A type)
- 192 Bytes of RAM
- 53 Parallel I/O Pins
 - 24 I/O Common Pins (Port 2, 3, 6)
 - 21 Output Pins (Port 1, 4, 7)
 - 8 Input Pins (Port 5)
- Driving Darlington Transistor (Port 2, 6)
- 16-bit Programmable Timer
 - Input Capture Register x 1
 - Free Running Counter x 1
 - Output Compare Register x 2
- 8-bit Reloadable Timer
 - External Event Count
 - Spare Wave Generation
- Serial Communication Interface (SCI)
 - Asynchronous Mode/Clock Synchronous Mode
 - 3 Transfer Formats (Asynchronous Mode)
 - 6 Clock Sources
- Memory Ready for Low Speed Memory Access
- Halt
- Error-Detection (Address Error, Op-code Error)
- Interrupts -- 3 External, 7 Internal
- Operation Mode
 - Mode 1 -- Expanded (Internal ROM Inhibited)
 - Mode 2 -- Expanded (Internal ROM Valid)
 - Mode 3 -- Single-chip Mode
- EPROM Mode
 - Up to 65k Bytes of Address Space
 - Low Power Dissipation Mode
 - Sleep
 - Standby
 - Minimum Instruction Execution Time -- $0.5\mu s$ ($f=2.0MHz$)
 - Wide Operation Range
 - $V_{CC}=5V\pm 10\%$
 - $f=0.5$ to $1.0MHz$; HD63701X0
 - $f=0.5$ to $1.5MHz$; HD637A01X0
 - $f=0.5$ to $2.0MHz$; HD637B01X0

[Precautions on using EPROM On-chip Single-chip Micro-computer]

- (1) If the MCU is exposed to strong light especially a fluorescent lamp or the sunlight, EPROM data may be erased or the MCU may malfunction by photocurrent. Therefore, after programming, it is suggested that applications which expose the LSI to ambient light may require an opaque label over the window.
- (2) Do not rub the window with materials like plastics, or do not touch a charged body on the window. Electro static charge may adversely affect the functionality of the LSI. A conductive opaque label, suggested above, is effective on distributing charge equally.

HD63701XOC, HD637A01XOC,
HD637B01XOC

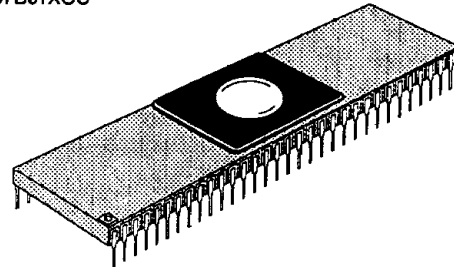

(DC-64S)

■ PIN ARRANGEMENT

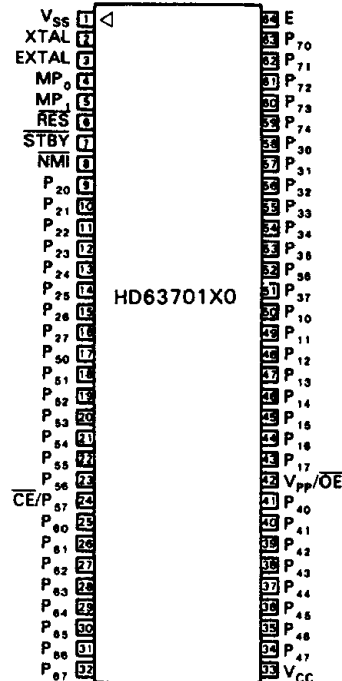

(Top View)

■ PROGRAM DEVELOPMENT SUPPORT TOOLS

- Cross assembler and C compiler software for IBM PCs and compatibles
- In circuit emulator for use with IBM PCs and compatibles
- Programming socket adapter for programming the EPROM-on-chip device.



■ BLOCK DIAGRAM

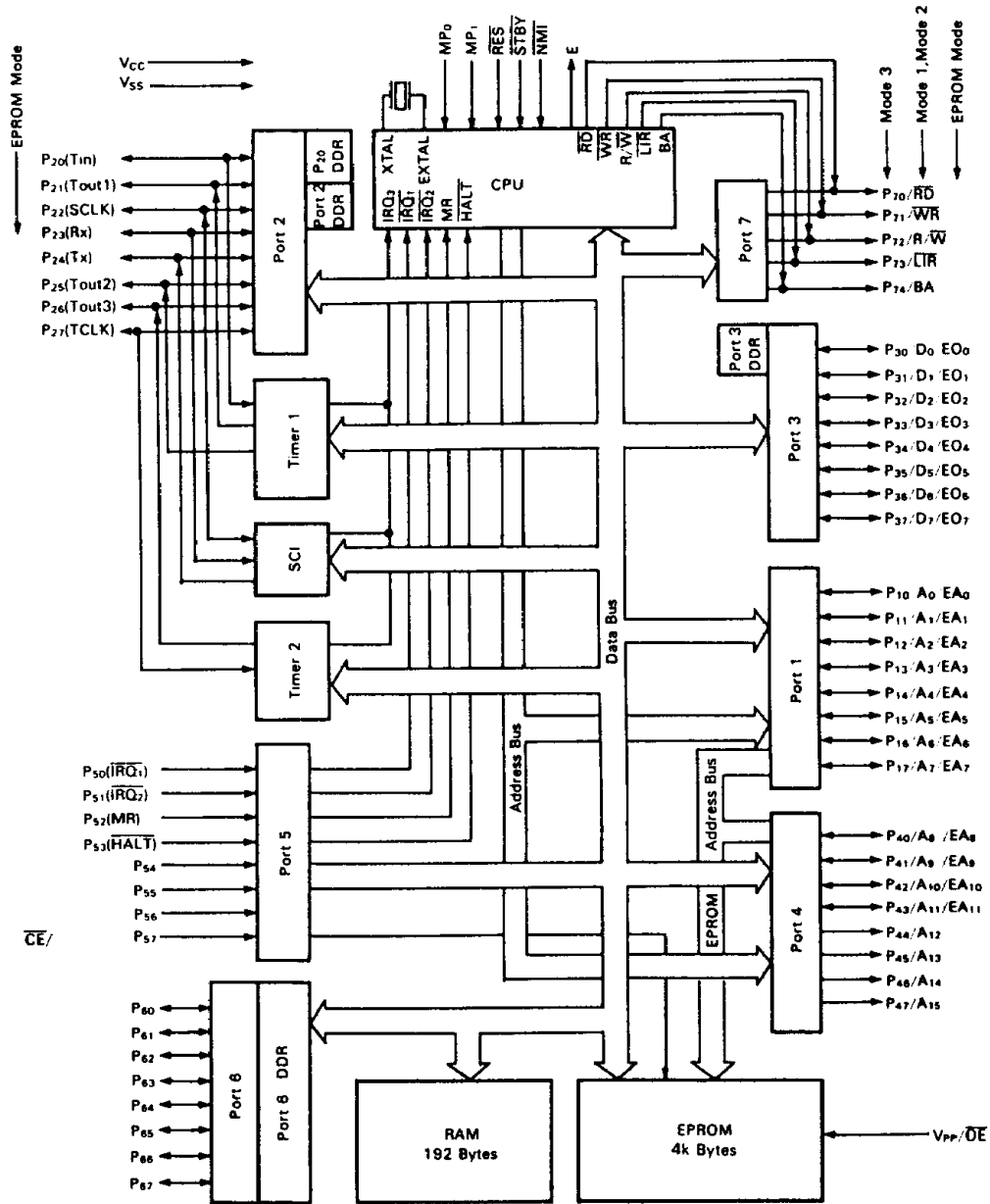

HD63701X0, HD637A01X0, HD637B01X0

■ ABSOLUTE MAXIMUM RATINGS

Item	Symbol	Value	Unit
Supply Voltage	V_{CC}	-0.3 ~ +7.0	V
Program Voltage	V_{PP}	-0.3 ~ +22	V
Input Voltage	V_{in}	-0.3 ~ $V_{CC}+0.3$	V
Operating Temperature	T_{opr}	0 ~ +70	°C
Storage Temperature	T_{stg}	-55 ~ +125	°C

(Note) This product has protection circuits in input terminal from high static electricity voltage and high electric field. But be careful not to apply overvoltage more than maximum ratings to these high input impedance protection circuits. To assure the normal operation, we recommend $V_{in}, V_{out}: V_{SS} \leq (V_{in} \text{ or } V_{out}) \leq V_{CC}$.

■ ELECTRICAL CHARACTERISTICS

- DC CHARACTERISTICS ($V_{CC} = 5V \pm 10\%$, $f = 0.1$ to 2.0 MHz, $V_{SS} = V_{PP} = 0V$, $T_a = -20 \sim +70^\circ C$, unless otherwise noted).

Item	Symbol	Test Condition	min	typ	max	Unit	
Input "High" Voltage	RES, STBY, MP0, MP1	V_{IH}	$V_{CC}-0.5$	—	$V_{CC}+0.3$	V	
	EXTAL		$V_{CC} \times 0.7$	—			
	Other Inputs		2.0	—			
Input "Low" Voltage	All Inputs	V_{IL}	-0.3	—	0.8	V	
Input Leakage Current	NMI, RES, STBY, MP0, MP1, Port 5	$ I_{in} $	$V_{in}=0.5 \sim V_{CC}-0.5V$	—	—	1.0	μA
Three State (off-state) Leakage Current	Ports 1, 2, 3, 4, 6, 7	$ I_{TSI} $	$V_{in}=0.5 \sim V_{CC}-0.5V$	—	—	1.0	μA
Output "High" Voltage	All Outputs	V_{OH}	$I_{OH} = -200\mu A$	2.4	—	—	V
			$I_{OH} = -10\mu A$	$V_{CC}-0.7$	—	—	V
Output "Low" Voltage	All Outputs	V_{OL}	$I_{OL} = 1.6mA$	—	—	0.4	V
				—	—	—	—
Darlington Drive Current		$-I_{OH}$	$V_{out} = 1.5V$	1.0	—	10.0	mA
Input Capacitance	All Inputs (Except V_{PP}/\overline{OE})	C_{in}	$V_{in}=0V, f=1MHz, T_a=25^\circ C$	—	—	12.5	pF
	V_{PP}/\overline{OE}			—	—	25.0	pF
Standby Current	Non Operation	I_{STB}		—	3.0	15.0	μA
Current Dissipation*	I_{SLP}		Sleeping ($f=1MHz^{**}$)	—	1.5	3.0	mA
			Sleeping ($f=1.5MHz^{**}$)	—	2.3	4.5	mA
			Sleeping ($f=2MHz^{**}$)	—	3.0	6.0	mA
	I_{CC}		Operating ($f=1MHz^{**}$)	—	7.0	10.0	mA
			Operating ($f=1.5MHz^{**}$)	—	10.5	15.0	mA
			Operating ($f=2MHz^{**}$)	—	14.0	20.0	mA
RAM Standby Voltage		V_{RAM}		2.0	—	—	V

* $V_{IH} \text{ min} = V_{CC}-1.0V, V_{IL} \text{ max} = 0.8V$ (All output terminals are at no load.)

**Current Dissipation of the operating or sleeping condition is proportional to the operating frequency. So the typ. or max. values about Current Dissipations at x MHz operation are decided according to the following formula;

$$\begin{aligned} \text{typ. value (f = X MHz)} &= \text{typ. value (f = 1MHz)} \times X \\ \text{max. value (f = X MHz)} &= \text{max. value (f = 1MHz)} \times X \\ &\text{(both the sleeping and operating)} \end{aligned}$$



HD63701X0, HD637A01X0, HD637B01X0

• AC CHARACTERISTICS ($V_{CC} = 5V \pm 10\%$, $f = 0.1$ to 2.0 MHz, $V_{SS} = V_{PP} = 0V$, $T_a = 0 \sim +70^\circ C$, unless otherwise noted).

BUS TIMING

Item	Symbol	Test Condition	HD63701X0			HD637A01X0			HD637B01X0			Unit	
			min	typ	max	min	typ	max	min	typ	max		
Cycle Time	t_{cyc}	Fig. 1	1	—	10	0.666	—	10	0.5	—	10	μs	
Enable Rise Time	t_{Er}		—	—	25	—	—	25	—	—	25	ns	
Enable Fall Time	t_{Ef}		—	—	25	—	—	25	—	—	25	ns	
Enable Pulse Width "High" Level*	PW_{EH}		450	—	—	300	—	—	220	—	—	ns	
Enable Pulse Width "Low" Level*	PW_{EL}		450	—	—	300	—	—	220	—	—	ns	
Address, R/W Delay Time*	t_{AD}		—	—	250	—	—	190	—	—	160	ns	
Data Delay Time	Write		t_{DDW}	—	—	200	—	—	160	—	—	120	ns
Data Set-up Time	Read		t_{DSR}	80	—	—	70	—	—	70	—	—	ns
Address, R/W Hold Time*	t_{AH}		70	—	—	45	—	—	30	—	—	ns	
Data Hold Time	Write*		t_{HW}	70	—	—	50	—	—	35	—	—	ns
	Read		t_{HR}	0	—	—	0	—	—	0	—	—	ns
RD, WR Pulse Width*	PW_{RW}		450	—	—	300	—	—	220	—	—	ns	
RD, WR Delay Time	t_{RWD}		—	—	40	—	—	40	—	—	40	ns	
RD, WR Hold Time	t_{HRW}		—	—	30	—	—	30	—	—	25	ns	
LIR Delay Time	t_{DLR}		—	—	200	—	—	160	—	—	120	ns	
LIR Hold Time	t_{HLR}		10	—	—	10	—	—	10	—	—	ns	
MR Set-up Time*	t_{SMR}		Fig. 2	400	—	—	280	—	—	230	—	—	ns
MR Hold Time*	t_{HMR}			—	—	90	—	—	40	—	—	0	ns
E Clock Pulse Width at MR	PW_{EMR}			—	—	9	—	—	9	—	—	9	μs
Processor Control Set-up Time	t_{PCS}		Fig. 3, 10, 11	200	—	—	200	—	—	200	—	—	ns
Processor Control Rise Time	t_{PCr}	Fig. 2, 3	—	—	100	—	—	100	—	—	100	ns	
Processor Control Fall Time	t_{PCf}		—	—	100	—	—	100	—	—	100	ns	
BA Delay Time	t_{BA}	Fig. 3	—	—	250	—	—	190	—	—	160	ns	
Oscillator Stabilization Time	t_{RC}	Fig. 11	20	—	—	20	—	—	20	—	—	ms	
Reset Pulse Width	PW_{RST}		3	—	—	3	—	—	3	—	—	t_{cyc}	

* These timings change in approximate proportion to t_{cyc} . These figures characteristically represent those when t_{cyc} is minimum (= in the highest speed operation).

PERIPHERAL PORT TIMING

Item	Symbol	Test Condition	HD63701X0			HD637A01X0			HD637B01X0			Unit	
			min	typ	max	min	typ	max	min	typ	max		
Peripheral Data Set-up Time	Ports 2, 3, 5, 6	t_{PDSU}	Fig. 5	200	—	—	200	—	—	200	—	—	ns
Peripheral Data Hold Time	Ports 2, 3, 5, 6	t_{PDH}	Fig. 5	200	—	—	200	—	—	200	—	—	ns
Delay Time (Enable positive Transition to Peripheral Data Valid)	Ports 1, 2, 3, 4, 6, 7	t_{PWED}	Fig. 6	—	—	300	—	—	300	—	—	300	ns



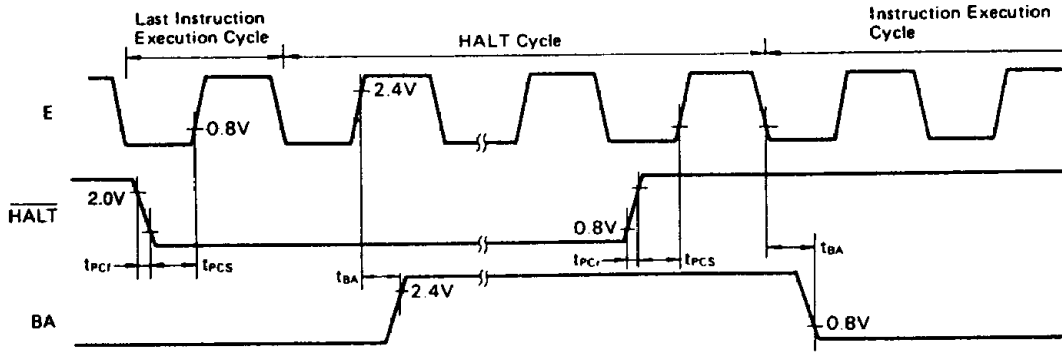

Figure 3 HALT and BA Timing

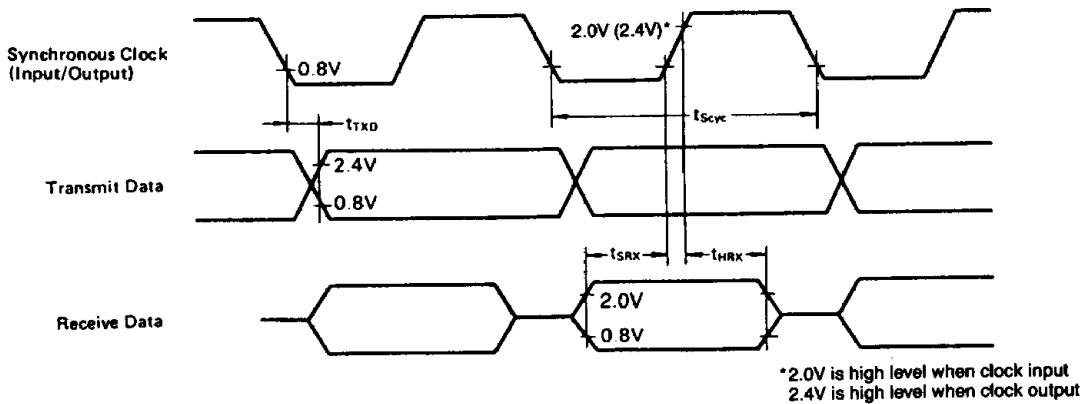

Figure 4 SCI Clocked Synchronous Timing

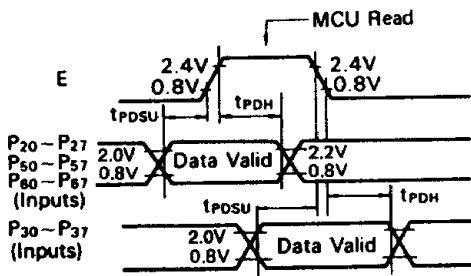

Figure 5 Port Data Set-up and Hold Times (MCU Read)

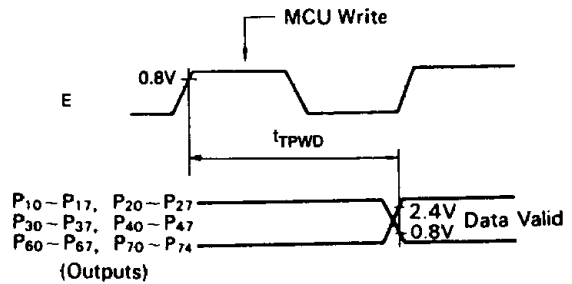
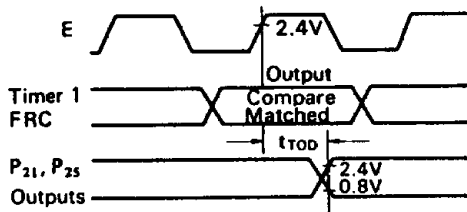
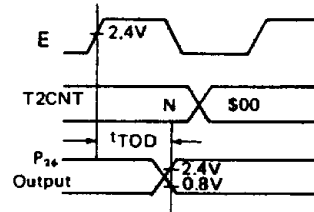

Figure 6 Port Data Delay Times (MCU Write)



(a) Timer 1 Output Timing



(b) Timer 2 Output Timing

Figure 7 Timer Output Timing

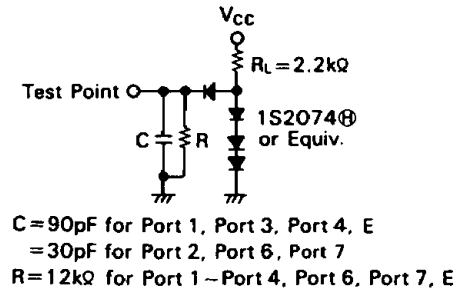
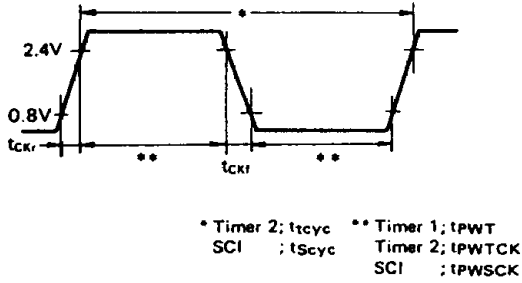

Figure 8 Timer 1-2, SCI Input Clock Timing

Figure 9 Bus Timing Test Loads (TTL Load)

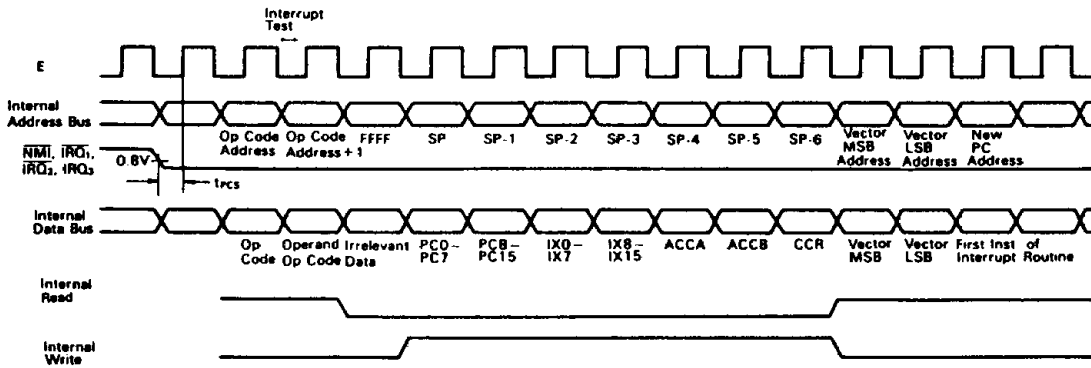

Figure 10 Interrupt Sequence

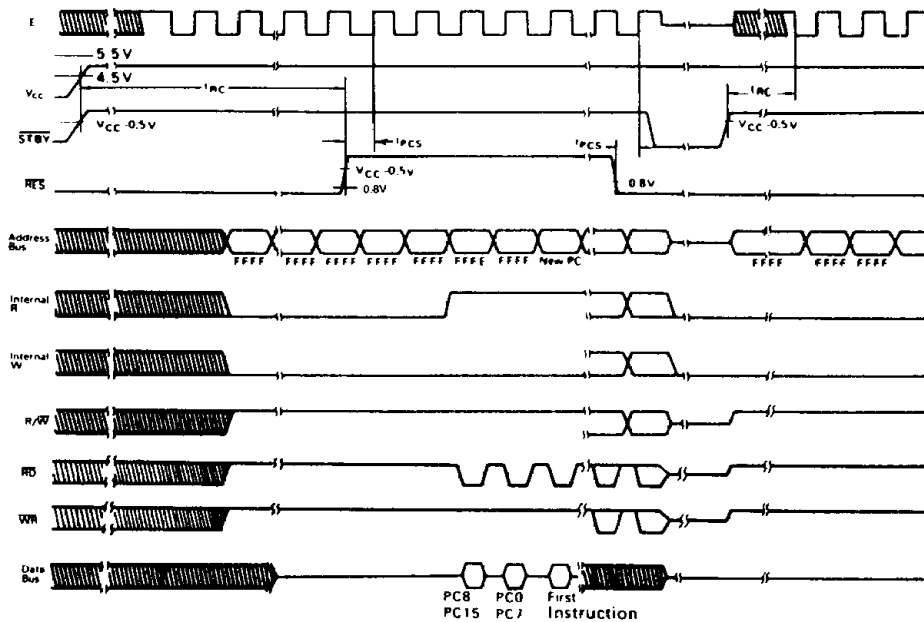

Figure 11 Reset Timing

HD63701X0, HD637A01X0, HD637B01X0

- EPROM PROGRAMMING ELECTRICAL CHARACTERISTICS
- DC CHARACTERISTICS ($V_{CC}=5V\pm 5\%$, $V_{PP}=21V\pm 0.5V$, $V_{SS}=0V$, $T_a=25^\circ C\pm 5^\circ C$, unless otherwise noted.)

Item	Symbol	Test Condition	min	typ	max	Unit
Program Voltage	V_{PP}		20.5	21	21.5	V
Program Current	I_{PP}	$V_{PP}=21V, \overline{CE}=V_{IV}$	—	—	30	mA
Input Leakage Current	I_{LI}	$V_{in}=5.25V/0.4V$	—	—	10	μA
Input "Low" Voltage	V_{IL}		-0.1	—	0.8	V
Input "High" Voltage	V_{IH}		2.2	—	$V_{CC}+1.0$	V
Output "Low" Voltage	V_{OL}	$I_{OL}+1.6mA$	—	—	0.45	V
Output "High" Voltage	V_{OH}	$I_{OH}=-200\mu A$	2.4	—	—	V

- AC CHARACTERISTICS ($V_{CC}=5V\pm 5\%$, $V_{PP}=21V\pm 0.5V$, $V_{SS}=0V$, $T_a=25^\circ C\pm 5^\circ C$, unless otherwise noted.)

Item	Symbol	Test Condition	min	typ	max	Unit
Address Set-up Time	t_{AS}		2	—	—	μs
Address Hold Time	t_{AH}		0	—	—	μs
\overline{OE} Set-up Time	t_{OES}		2	—	—	μs
\overline{OE} Hold Time	t_{OEH}		2	—	—	μs
Data Set-up Time	t_{DS}		2	—	—	μs
Data Hold Time	t_{DH}		2	—	—	μs
Output Disable Delay Time	t_{DF}		0	—	130	ns
Data Valid from \overline{CE}	t_{DV}	$\overline{CE}=V_{IL}, \overline{OE}=V_{IL}$	—	—	1	μs
\overline{CE} Pulse Width	t_{PW}		45	50	55	ms
\overline{OE} Pulse Rise Time	t_{PRT}		50	—	—	ns
V_{PP} Recovery Time	t_{VR}		2	—	—	μs

(Note) t_{DF} is defined when output becomes open because output level can not be referred.

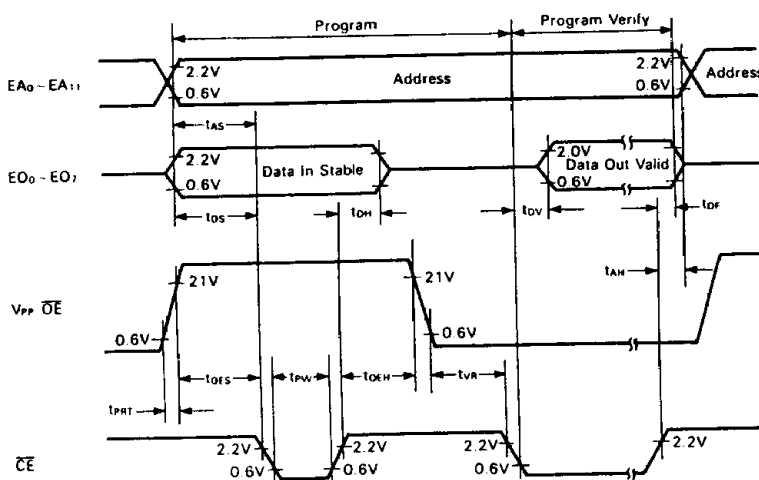

Figure 12 EPROM Programming Timing



HD63701X0, HD637A01X0, HD637B01X0

FUNCTIONAL PIN DESCRIPTION

V_{CC}, V_{SS}

V_{CC} and V_{SS} provide power to the MCU with 5V ± 10% supply. V_{SS} pin should be tied to ground.

XTAL, EXTAL

These two pins interface a crystal (an AT-cut type). Divide-by-four circuit is on chip. When 4MHz crystal is used, the system clock is 1MHz for example.

EXTAL pin may be driven with an external clock of 45 to 55% duty, and one fourth frequency of the external clock is produced in the LSI. The external clock frequency should be less

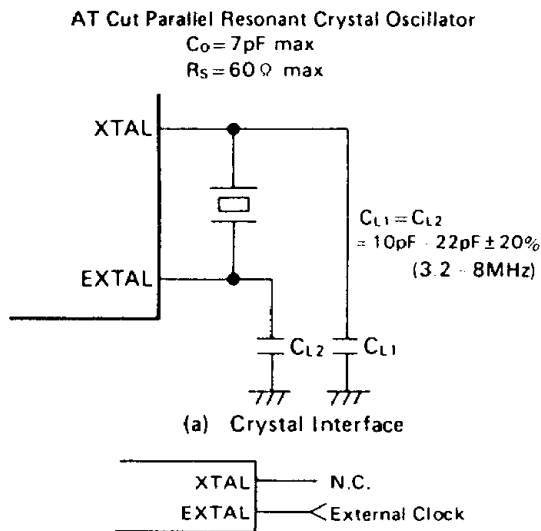

Figure 13 Connection Circuit

than four times of the maximum frequency. When using the external clock, XTAL pin should be open. Fig. 13 shows an example of connection circuit. The crystal and C_{L1}, C_{L2} should be mounted as close as possible to XTAL and EXTAL pins. Any line must not cross the line between the crystal and XTAL, EXTAL.

STBY

This pin is used for standby mode or EPROM mode.

In standby mode, the oscillation may be stopped. To retain the contents of RAM at standby, "0" should be written into RAM enable bit (RAMW). RAME is the bit 6 of the RAM/port 5 control register at \$0014. RAM is disabled by this operation and its contents is sustained. Refer to "LOW POWER DISSIPATION MODE" for standby mode.

When this pin and Mode Program pins, MP₀ and MP₁, are "Low" level, the MCU is in EPROM mode. Refer to "PROGRAMMING THE EPROM" for details.

Reset (RES)

This pin is used to reset the MCU's internal state and provide a startup procedure. During power up, RES pin must be held below "Low" level for more than 20 ms.

The CPU registers (accumulator, index register, stack pointer, condition code register except for interrupt mask bit), RAM and data registers of ports are not initialized during reset, so their contents are unknown in a startup procedure.

To reset the MCU during operation, RES should be held "Low" for at least 3 system-clock cycles. At the 3rd cycle, all the address buses become "High". When RES remains "Low", the

address buses keep "High". If RES turns "High", the MCU restart sequence is:

- (1) Latch the value of the mode program pins: MP₀ and MP₁.
- (2) Initialize each internal register (refer to Table 5).
- (3) Set the interrupt mask bit. For the CPU to recognize the maskable interrupts \overline{IRQ}_1 , \overline{IRQ}_2 and IRQ₃, this bit should be cleared in advance.
- (4) Put the contents (=start address) of the last two addresses (\$FFFE, \$FFFF) into the program counter and start the program from this address. (Refer to Table 1).

The MCU is unable to accept a reset input until the clock becomes normal oscillation after power on (max. 20ms). During this transient time, the MCU and I/O pins are undefined. Please be aware of this for system designing.

Enable (E)

This pin provides a TTL-compatible clock used for bus synchronization. Its frequency is one fourth that of the internal oscillator or external clock. This pin can drive one TTL load and 90pF capacitance.

Non-Maskable Interrupt (NMI)

When the negative edge of the input signal is detected at this pin, the CPU will begin a non-maskable interrupt sequence. But the current instruction will be completed before it responds to the request. The interrupt mask bit of the condition code register doesn't affect non-maskable interrupt at all.

When the interrupt occurs, the contents of the program counter, the index register, the accumulators and the condition code register will be pushed onto the stack. Upon completion of this sequence, a vector is fetched from \$FFFC and \$FFFD, transferred their contents to the program counter and the non-maskable interrupt service routine starts. After reset, the stack pointer should be initialized on an appropriate memory area before NMI input.

Interrupt Request (\overline{IRQ}_1 , \overline{IRQ}_2)

These are level-sensitive pins which request an internal interrupt sequence. At interrupt request, the CPU will complete the current instruction before it responds to the request. If the interrupt mask in the condition code register is clear, the CPU will begin an interrupt sequence; if set, the interrupt request will be ignored. When the sequence starts, the contents of the program counter, the index register, the accumulators and the condition code register will be pushed onto the stack, then the interrupt mask bit will be set and inhibits all maskable interrupt. Finally, a vector is fetched from an address depicted in Table 1 and transferred to the program counter, and instruction execution is resumed.

The external interrupt pins, \overline{IRQ}_1 and \overline{IRQ}_2 are also used for port pins P₅₀ and P₅₁, so it is controlled by Bit 0 and 1 of the RAM/port 5 control register at \$0014. Refer to "RAM/PORT 5 CONTROL REGISTER" for details.

One of the internal interrupts, ICI, OCI, TOI, CMI or SIO can generate an internal interrupt (IRQ_i). IRQ₃ function is just the same as \overline{IRQ}_1 or \overline{IRQ}_2 except the vector address. Fig. 14 shows the block diagram of the interrupt circuit.

Mode Program (MP₀, MP₁)

These two pins decide the operation mode. Refer to "MODE SELECTION" for more details.

Table 1 Interrupt Vector Memory Map

Priority	Vector		Interrupt
	MSB	LSB	
Highest ↑ ↓ Lowest	FFFE	FFFF	\overline{RES}
	FFEE	FFEF	TRAP
	FFFC	FFFD	\overline{NMI}
	FFFA	FFFB	SWI (Software Interrupt)
	FFF8	FFF9	$\overline{IRQ_1}$
	FFF6	FFF7	ICI (Timer 1 Input Capture)
	FFF4	FFF5	OCI (Timer 1 Output Compare 1, 2)
	FFF2	FFF3	TOI (Timer 1 Overflow)
	FFEC	FFED	CMI (Timer 2 Counter Match)
	FFEA	FFEB	$\overline{IRQ_2}$
	FFF0	FFF1	SIO (RDRF+ORFE+TDRE)

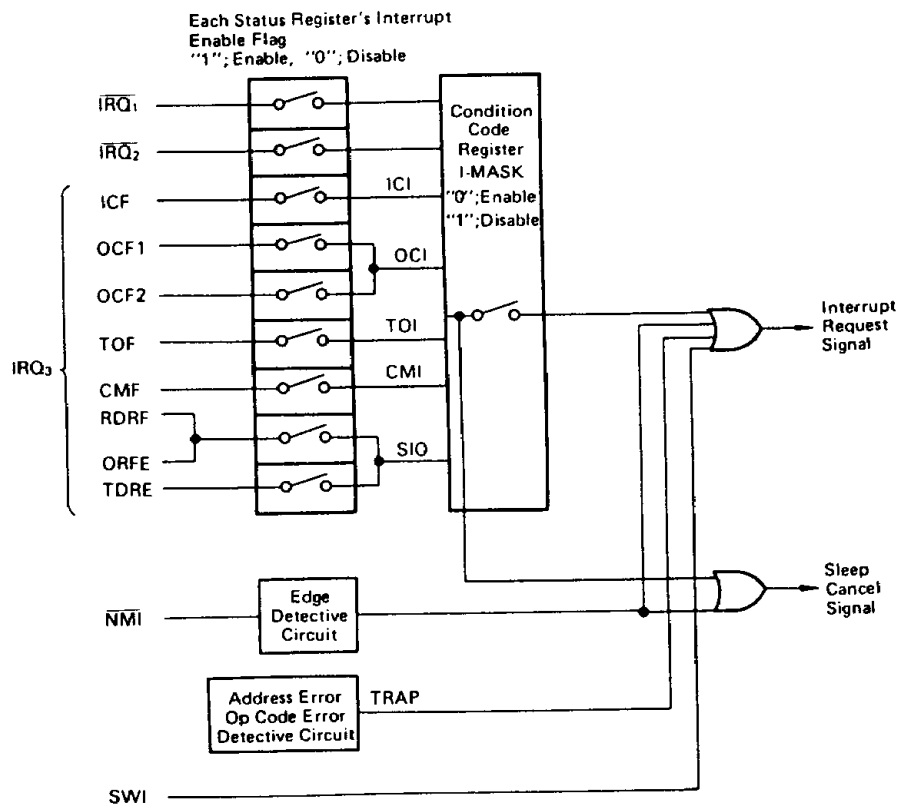

Figure 14 Interrupt Circuit Block Diagram

HD63701X0, HD637A01X0, HD637B01X0

The following signal descriptions are applied only for expanded mode.

- **Read/Write (R/W; P₇₂)**

This signal, usually in read state ("High"), shows whether the MCU is in read ("High") or write ("Low") state. This can drive one TTL load and 30pF capacitance.

- **\overline{RD} , \overline{WR} (P₇₀, P₇₁)**

These outputs will turn "Low" when the CPU read/write operation is completed. This enables the CPU easy to access the peripheral LSI with \overline{RD} and \overline{WR} input pins. These pins can drive one TTL load and 30pF capacitance.

- **Load Instruction Register (\overline{LIR} ; P₇₃)**

This is output for the instruction opcode on data bus (active low). This pin can drive one TTL load and 30pF capacitance.

- **Memory Ready (MR; P₅₂)**

This input is used to stretch the system clock's "High" period in order to access low-speed memories. During this signal being in "High", the system clock operates in normal sequence. But in "Low", the "High" period of the system clock will be stretched in integral multiples of the cycle time. This allows the CPU to interface with low-speed memories (See Fig. 2). Up to 9 μ s can be stretched.

During internal address access or nonvalid memory access, MR is prohibited internally to prevent decrease of operation speed. Even in the halt state, MR can also stretch "High" period of system clock to allow peripheral devices to access low-speed memories. As this pin is used also for P₃₂, an enable bit is provided at bit 2 of the RAM/port 5 control register at \$0014. Refer to "RAM/PORT 5 CONTROL REGISTER" for more details.

- **Halt (\overline{HALT} ; P₅₃)**

This input is used to stop instruction execution or to release buses free. When this signal turns "Low", the CPU will be in the halt state after completing the current instruction. During the halt state, BA (P₂₁) is in "High", and an address bus, data bus, \overline{RD} , \overline{WR} and R/W are high impedance. When an interrupt is requested in the halt state, the CPU responds to the interrupt request after the halt is cancelled. When halted during the sleep state, the CPU keeps the sleep state, and BA is "High" and the buses are high impedance. Then the CPU returns to the previous sleep state when the \overline{HALT} goes "High".

(Note) When the CPU is interrupt wait state in WAI instruction execution, \overline{HALT} should be held "High". If \overline{HALT} turns "Low", the CPU may malfunction after releasing the halt state.

- **Bus Available (BA; P₇₄)**

This output is normally "Low" but "High" when the CPU accepts \overline{HALT} and releases the buses. The HD6800 and HD6802 make BA "High" and release the buses at WAI execution, while the HD63701X0 doesn't make BA "High" under the same condition.

The following pin functions are applied only in EPROM mode. Refer to "PROGRAMMING THE EPROM" for details of EPROM mode.

- **Chip Enable (\overline{CE} ; P₅₇)**

This pin is input for programming and verifying the EPROM. When this pin is "Low" level, EPROM will be enable.

The EPROM can not be programmed or verified in "High" level.

- **Program Voltage/Output Enable (V_{pp}/ \overline{OE})**

This pin is used for program voltage and data output control in verification.

Data from Port 3 (EO₀ to EO₇) can be programmed into the EPROM when applying 21V \pm 0.5V to V_{pp} and holding \overline{CE} in "Low" level. The EPROM address is provided to Port 1 and Port 4 (EA₀ to EA₁₁). In verification, the EPROM data is output from Port 3 (EO₀ to EO₇) when this pin is "Low" level. In "High" level, Port 3 will be high-impedance. In MCU mode, this pin should be connected to V_{SS}.

- **PORT**

The HD63701X0 has six 8-bit ports and a 5-bit port. Table 2 gives the address of ports and the data direction register and Fig. 15 the block diagrams of each port.

Table 2 Port and Data Direction Register Address

Port	Port Address	Data Direction Register
Port 1	\$0002	—
Port 2	\$0003	\$0001
Port 3	\$0006	\$0004
Port 4	\$0007	—
Port 5	\$0015	—
Port 6	\$0017	\$0016
Port 7	\$0018	—

- **Port 1**

In MCU mode, port 1 is used for an 8-bit output port. In mode 3, port 1 is high impedance during reset, and keeps the state even after reset is released. When the CPU writes on the port 1 data register, the written data will appear at Port 1. Once port 1 gets in the output state, it operates as an output till reset. The CPU can read the Port 1 data register for the bit manipulation instruction.

In mode 1 and 2, port 1 is used for lower address buses. This port can drive one TTL load and 90pF capacitance.

In EPROM mode, port 1 is lower address bus (EA₀ to EA₇) for the EPROM.

- **Port 2**

An 8-bit input/output port. Its I/O state depends on the data direction register (DDR) of port 2 which provides two bits; bit 0 decides the I/O direction of P₂₀ and bit 1 the I/O direction of P₂₁ to P₂₇ ("0" for input, "1" for output).

Port 2 is also used for the timers and the SCI. When used for the timers and the SCI, P₂₁ to P₂₇ are decided I/O regardless of the DDR (except for P₂₀).

Port 2 Data Direction Register

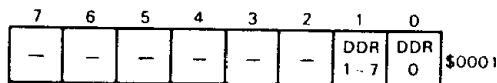

The DDR of port 2 is cleared at reset and port 2 is configured as an input. This port can drive one TTL and 30pF. In addition, it is capable of sinking 1mA current at V_{out}=1.5V to drive directly the base of Darlington transistors.

- **Port 3**

An 8-bit I/O port. I/O state depends on the DDR of Port 3 which has only one bit ("0" for input and "1" for output). It is cleared at reset. In mode 1 and 2, port 3 is used for data bus. This port can drive one TTL load and 90pF capacitance.

Port 3 is used for data bus (EO₀ to EO₇) of EPROM in



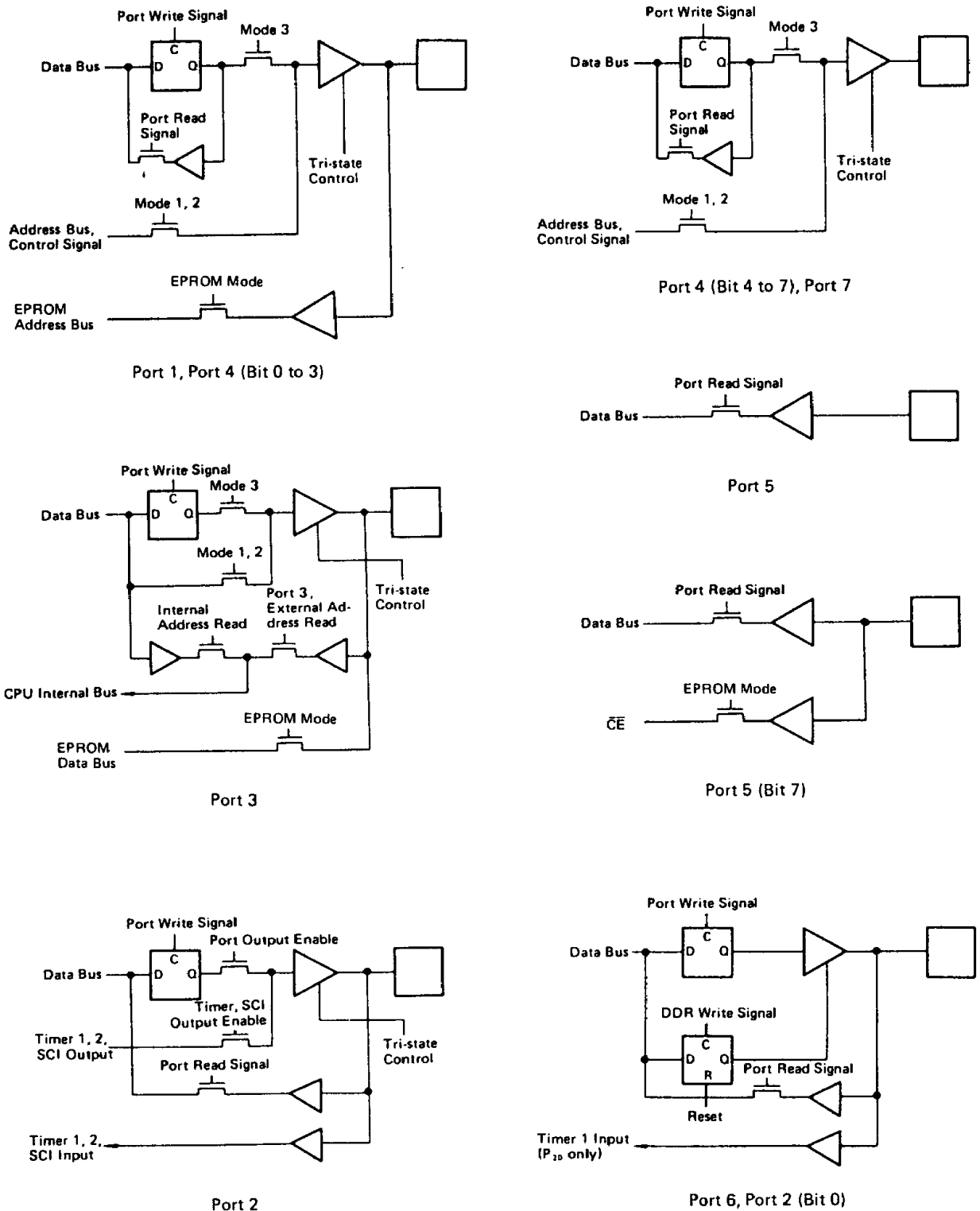

Figure 15 Port Block Diagram

HD63701X0, HD637A01X0, HD637B01X0

EPROM mode. In this case, I/O state of Port 3 is selected by \overline{OE} but not the DDR.

Port 3 Data Direction Register

7	6	5	4	3	2	1	0
-	-	-	-	-	-	-	Port3 DDR

\$0004

● **Port 4**

In MCU mode, port 4 is used for an 8-bit output port like Port 1. In mode 1 and 2, it is used for upper address bus.

In EPROM mode, P_{40} to P_{43} are used for upper address bus (EA_n to EA_{11}) of EPROM.

● **Port 5**

An 8-bit input port. The lower 4 bits are used for interrupt, MR, HALT, and P_{57} is \overline{CE} for the EPROM control.

● **Port 6**

An 8-bit I/O port. This port is programmable as either input or output under software control of the corresponding the DDR ("0" for input, "1" for output). This port can drive one TTL load and 30pF. The DDR of port 6 is cleared at reset. In addition, it is capable to sinking 1mA current at $V_{out}=1.5V$ to drive directly the base of Darlington transistors.

● **Port 7**

A 5-bit output port. In mode 3, port 7 is high impedance during reset and keeps the state even after reset is released. When the CPU writes on the port 7 data register, the written data will appear at Port 7. Once port 7 gets in the output state, it operates as an output till reset. The CPU can read the data register for the bit manipulation instruction. In this case b_7 to b_5 are "1".

In mode 1 and 2, port 7 is used for control signals (\overline{RD} , \overline{WR} , R/W , \overline{CLR} and BA). This port can drive one TTL load and 30pF.

■ **RAM/PORT 5 CONTROL REGISTER**

The control register located at \$0014 controls on-chip RAM and port 5.

RAM/Port 5 Control Register

7	6	5	4	3	2	1	0
STBY PWR	RAME	-	-	HLTE	MRE	IRQ ₂ E	IRQ ₁ E

\$0014

Bit 0, Bit 1 $\overline{IRQ_1}$, $\overline{IRQ_2}$ Enable Bit (IRQ₁E, IRQ₂E)

When using P_{50} and P_{51} for interrupt pins, write "1" in these bits. When "0", the CPU doesn't accept an external interrupt or a sleep cancellation by the external interrupt. These bits are cleared at reset.

Bit 2 Memory Ready Enable Bit (MRE)

When using P_{52} for an input for Memory Ready signal, write "1" in this bit. When "0", the memory ready function is prohibited and P_{52} is for port. In mode 3, the memory ready function is prohibited regardless of the value of this bit. This bit is set at reset.

Bit 3 Halt Enable Bit (HLTE)

When using P_{53} for an input for Halt signal, write "1" in this bit. When "0", the halt function is prohibited. In mode 3, the

halt function is prohibited regardless of the value of this bit. This bit is set at reset.

(Note) When using P_{52} and P_{53} for port in mode 1 and 2, MRE and MLTE must be cleared after reset.

Bit 4, Bit 5 Not Used.

Bit 6 RAM Enable (RAME)

The RAM is controlled by this bit. It is set at reset and the RAM is enabled. This bit is programmable by software. When the RAM is disabled (=logic "0"), the CPU can access an external memory. This bit should be cleared at the beginning of standby mode to protect the RAM data.

Bit 7 Standby Power Bit (STBY PWR)

This bit is cleared whenever V_{CC} decreases below V_{RAM} (min). This is a read/write status bit by software. If this bit is set before standby mode, it indicates that V_{CC} is applied and the RAM is valid.

HD63701X0, HD637A01X0, HD637B01X0

■ MODE SELECTION

The HD63701X0 provides two fundamental modes, MCU mode and EPROM mode. MCU mode is grouped into three; two expanded modes (mode 1, mode 2) and a single chip mode (mode 3).

These operating modes are selectable by mode program pins, MP_0 and MP_1 , and standby pin, \overline{STBY} as shown in Table 3.

● Mode 1 (Expanded Mode)

In this mode, Port 3 is data bus, Port 1 is lower address bus and Port 4 is upper address bus to interface with the HMCS6800 buses. Port 7 is used for control signal such as R/W. In mode 1, the EPROM is disable and external address space are expandable up to 65k bytes (refer to Fig. 16).

● Mode 2 (Expanded Mode)

This mode is also expanded mode. But in mode 2, address space is expandable up to 61k bytes and the EPROM is enable (refer to Fig. 17).

● Mode 3 (Single-chip Mode)

In this mode, all ports are available (refer to Fig. 18).

● EPROM Mode

In this mode, the EPROM can be programmed. Refer to "PROGRAMMING THE EPROM" for details.

● Mode and Ports

Table 4 shows the MCU signals in each mode.

Table 3 Mode Selection

Mode	MP_1	MP_0	\overline{STBY}	EPROM	RAM	Interrupt Vector	Operation Mode	
MCU Mode	1	"L"	"H"	*	E	(Note 1)	E	Expanded Mode
	2	"H"	"L"	*		(Note 1)		Expanded Mode
	3	"H"	"H"	*				Single-chip Mode
EPROM Mode	"L"	"L"	"L"		*	*	EPROM Programming Mode	

"L"=Logic "0", "H"=Logic "1", |; Internal, E; External, *: Don't care
(Note 1) The RAM address area will be external by clearing RAME bit at \$0014.

Table 4 MCU Signals in Each Mode

Port	MCU Mode			EPROM Mode
	Mode 1	Mode 2	Mode 3	
Port 1	Address Bus ($A_0 \sim A_7$)	Address Bus ($A_0 \sim A_7$)	Output Port	Address Bus ($EA_0 \sim EA_7$)
Port 2	I/O Port	I/O Port	I/O Port	No use (Note 3)
Port 3	Data Bus ($D_0 \sim D_7$)	Data Bus ($D_0 \sim D_7$)	I/O Port	Data Bus ($EO_0 \sim EO_7$)
Port 4	Address Bus ($A_8 \sim A_{15}$)	Address Bus ($A_8 \sim A_{15}$)	Output Port	Address Bus ($EA_8 \sim EA_{11}$) (Note 1)
Port 5	Input Port	Input Port	Input Port	\overline{CE} (P_{57}) (Note 2)
Port 6	I/O Port	I/O Port	I/O Port	No use (Note 3)
Port 7	\overline{RD} , \overline{WR} , R/\overline{W} , LIR , BA	\overline{RD} , \overline{WR} , R/\overline{W} , LIR , BA	Output Port	No use (Note 3)

(Note 1) Use only 4 pins P_{40} to P_{43} . P_{44} to P_{47} are not used.

(Note 2) 7 pins P_{50} to P_{56} are not used.

(Note 3) Unused ports should be connected to V_{SS} .

HD63701X0, HD637A01X0, HD637B01X0

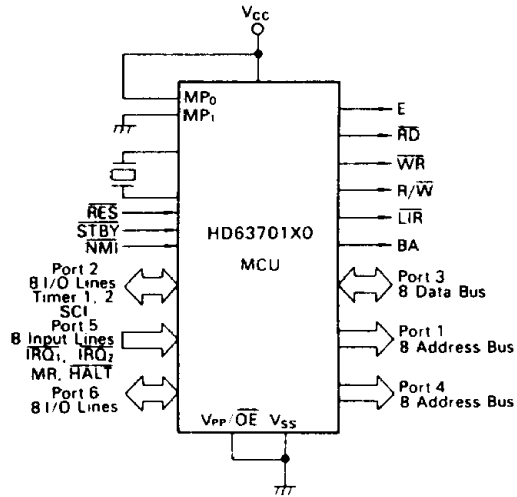

Figure 16 MCU Mode; Mode 1

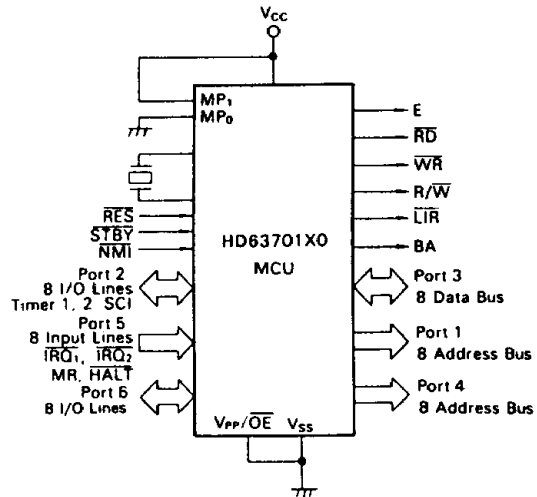

Figure 17 MCU Mode; Mode 2

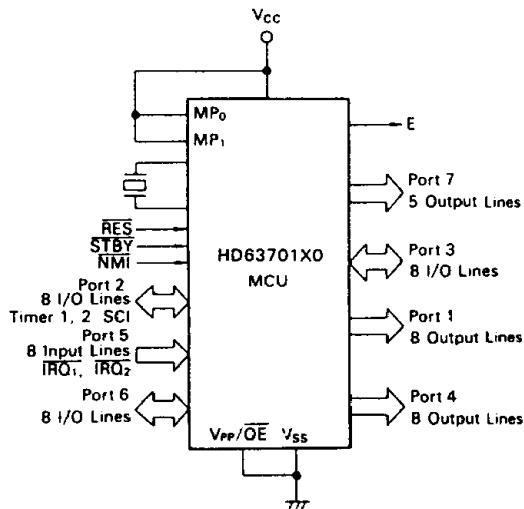

Figure 18 MCU Mode; Mode 3

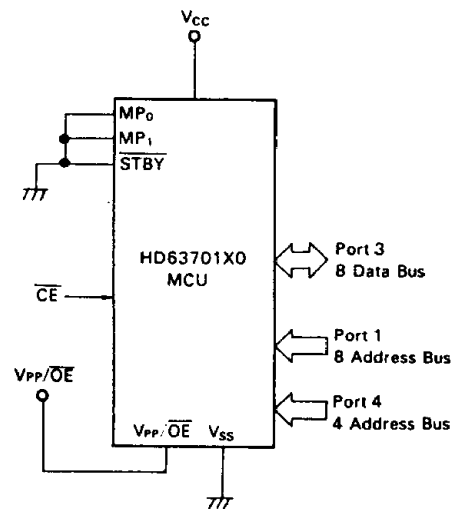

Figure 19 EPROM Mode



HD63701X0, HD637A01X0, HD637B01X0

■ MEMORY MAP

The MCU has ability to access a 65k byte memory space depending on the operating mode. A memory map for each operating mode is shown in Fig. 20. The first 32 locations of each map are reserved for the MCU's internal register area, as shown in Table 5.

ing mode is shown in Fig. 20. The first 32 locations of each map are reserved for the MCU's internal register area, as shown in Table 5.

Table 5 Internal Register

Address	Registers	R/W***	Initialize at RESET
00	-	-	-
01	Port 2 Data Direction Register	W	\$FC
02*	Port 1	R/W	Undefined
03	Port 2	R/W	Undefined
04*	Port 3 Data Direction Register	W	\$FE
05	-	-	-
06*	Port 3	R/W	Undefined
07*	Port 4	R/W	Undefined
08	Timer Control/Status Register 1	R/W	\$00
09	Free Running Counter ("High")	R/W	\$00
0A	Free Running Counter ("Low")	R/W	\$00
0B	Output Compare Register 1 ("High")	R/W	\$FF
0C	Output Compare Register 1 ("Low")	R/W	\$FF
0D	Input Capture Register ("High")	R	\$00
0E	Input Capture Register ("Low")	R	\$00
0F	Timer Control/Status Register 2	R/W	\$10
10	Rate, Mode Control Register	R/W	\$00
11	Tx/Rx Control Status Register	R/W	\$20
12	Receive Data Register	R	\$00
13	Transmit Data Register	W	\$00
14	RAM/Port 5 Control Register	R/W	\$7C or \$FC
15	Port 5	R	-
16	Port 6 Data Direction Register	W	\$00
17	Port 6	R/W	Undefined
18*	Port 7	R/W	Undefined
19	Output Compare Register 2 ("High")	R/W	\$FF
1A	Output Compare Register 2 ("Low")	R/W	\$FF
1B	Timer Control/Status Register 3	R/W	\$20
1C	Time Constant Register	W	\$FF
1D	Timer 2 Up Counter	R/W	\$00
1E	-	-	-
1F**	Test Register	-	-

- * External Address in Mode 1, 2.
- ** Test Register. Do not access to this register.
- *** R : Read Only Register
- W : Write Only Register
- R/W: Read/Write Register

HD63701X0, HD637A01X0, HD637B01X0

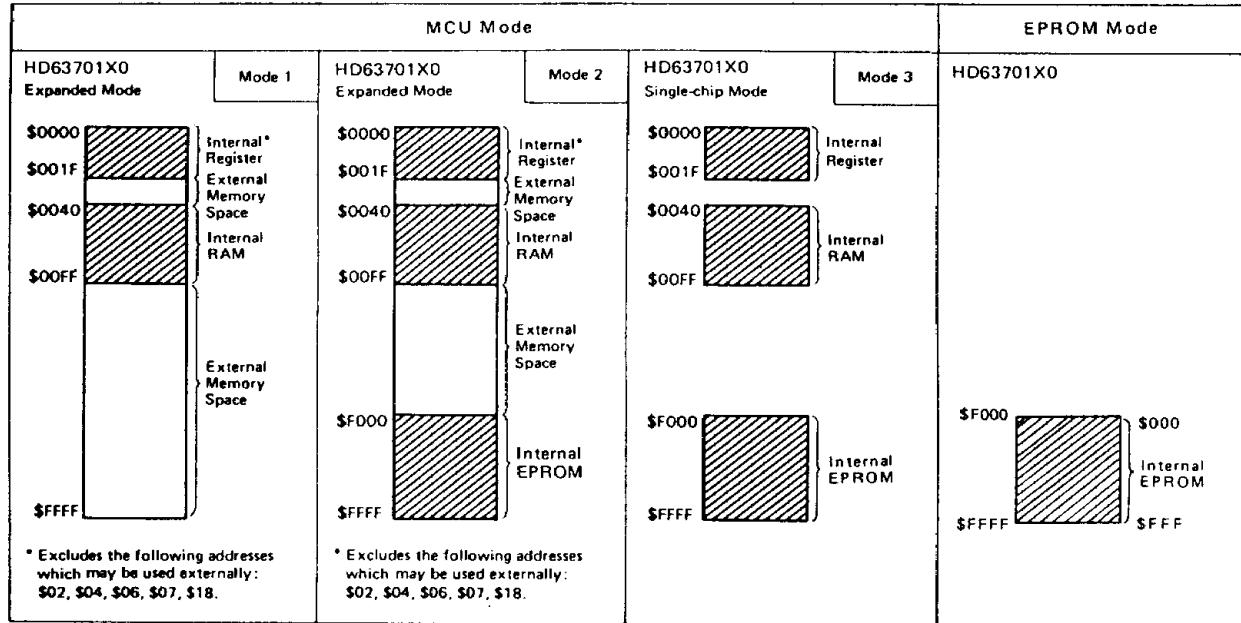

Figure 20 HD63701X0 Memory Map

PROGRAMMING THE EPROM

The HD63701X0 does not operate as the MCU in EPROM mode, which allows to be programmable as equivalent EPROM 2732A type. When three pins, MP_0 , MP_1 and \overline{STBY} should be held low, the MCU will be in EPROM mode as shown in Table 3. In this mode, P_{30} to P_{37} are used for data bus, P_{10} to P_{17} and P_{40} to P_{43} for address bus, and P_{17} for \overline{CE} input. (Refer to Fig. 19.)

Programming/Verification

When \overline{CE} pin is held low after the program voltage (V_{PP}) is applied to V_{PP}/\overline{OE} pin, the data byte can be applied to Port 3. When V_{PP}/\overline{OE} pin and \overline{CE} pin are held low after programming, the programmed data is output from Port 3 and user can verify the data. I/O timing of these signals are referred to Fig. 12.

When \overline{CE} pin is returned to high, Port 3 will be tri-state and EPROM programming/verification will be inhibited.

Table 6 shows the condition of the each pin is EPROM mode. Unused pins should be connected to GND in EPROM mode.

Erasure

Erasure of EPROM begins to occur when the LSI is exposed to ultraviolet light (wavelength, 2537 Å, an intensity of at least: 1.5W-sec/cm²). Exposing the LSI to an ultraviolet lamp of 1,200 μW/cm² rating for 20 to 30 minutes, at a distance of about 1 inch, should be sufficient.

(Note) If the glass window is stained, erasure time will be extended. Remove stains from the window with a solvent which has no influence on the package like alcohol. Don't rub the window hard but wipe out softly.

TIMER 1

The HD63701X0 has a 16-bit programmable timer which can be used to perform input waveform measurements while generating two independent output waveforms. The pulse width can vary from several microseconds to many seconds.

Timer 1 is configured as follows (refer to Fig. 22).

Table 6 Pin Condition in EPROM mode

Pin No.	V _{CC}	V _{SS}	V _{PP} / \overline{OE}	\overline{CE}	P ₃₀ to P ₃₇	P ₁₀ to P ₁₇ P ₄₀ to P ₄₃	MP ₀ , MP ₁ , \overline{STBY}	Other pins
	Mode	33	1	42	24	51 to 58	43 to 50 38 to 41	4, 5, 7
Programming	+5	GND	V _{PP}	"L"	Data input	Address input	"L"	GND
Verification	+5	GND	"L"	"L"	Data output	Address input	"L"	GND
Inhibition of programming/verification	+5	GND	Don't care	"H"	High impedance	Don't care	"L"	GND

"H": V_{IH} level, "L": V_{IL} level



- Control/Status Register 1 (8 bit)
- Control/Status Register 2 (7 bit)
- Free Running Counter (16 bit)
- Output Compare Register 1 (16 bit)
- Output Compare Register 2 (16 bit)
- Input Capture Register (16 bit)

● **Free-Running Counter (FRC) (\$0009 : 000A)**

The key timer element is a 16-bit Free-Running Counter which is incremented by system clock (E). The counter value is readable by software without affecting the FRC. It is cleared by reset.

A write to the high byte of the FRC (\$09) will preset the high and low byte of the FRC to \$FFF8. A continuous write to the high and low byte FRC, however, will set them to the write data.

The FRC write timing will be as follows when double store instructions (STD, STX etc.) execute.

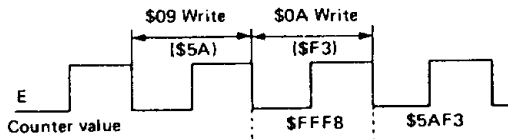

Figure 21 Counter Write Timing

● **Output Compare Register (OCR) (\$000B, \$000C; OCR1) (\$0019, \$001A; OCR2)**

The Output Compare Register is a 16-bit read/write register used to control an output waveform. It is always compared with the FRC on each E-cycle.

When a match is found, Output Compare Flag (OCF) in the Timer Control/Status Register (TCSR) is set. If an output enable bit (OE) in the TCSR2 is "1", an output level bit (OLVL) in the TCSR will appear at Port 21 (Tout 1) or Port 25 (Tout 2).

The OCR and OLVL can then be changed for the next compare. The OCR is set to \$FFFF at reset. The compare function is inhibited for a cycle after a write to the OCR or to the high byte of the FRC. This is to set the 16-bit value valid in the register for compare. In addition, it is because \$FFF8 is set at the next cycle of a write to the high byte of the FRC.

- For a write to the FRC or the OCR, 2-byte transfer instruction (such as STX etc.) should be used.

● **Input Capture Register (ICR) (\$000D : 000E)**

The Input Capture Register is a 16-bit read only register used to store the FRC when an external input transition occurs defined by input edge bit (IEDG) in the TCSR1.

In order to input the external signal to the edge detective circuit, Port 20 should be configured as an input. When an input capture occurs at the next cycle of a read the high-byte of the ICR, the input capture will delay one cycle. In order to ensure the input capture, a read to the ICR needs 2-byte transfer instruction, and the input pulse width should be at least 2 system cycles. This register is cleared (\$0000) at reset.

● **Timer Control/Status Register 1 (TCSR1) (\$0008)**

The Timer Control/Status Register 1 is an 8-bit register of which all bits are readable while the lower 5 bits can be written. The upper 3 bits indicate the following timer's status.

- Bit 5 The FRC has overflowed. (TOF).
- Bit 6 A match has been found between the FRC and the OCR 1 (OCF1).
- Bit 7 A level transition of the timer input has been detected (ICF).

The followings are each bit descriptions.

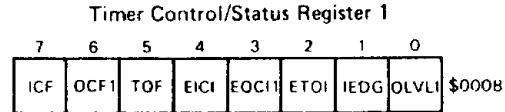

- Bit 0 **OLVL1 Output Level 1**
When a match is found between the FCR and the OCR1, OLVL1 will appear at Port 21 if OE1, bit 0 of the TCSR2, is set.
- Bit 1 **IEDG Input Edge**
This bit controls which level transition will trigger the FCR transfer to the ICR. For this function, the DDR corresponding to Port 20 should be cleared. IEDG=0, transferred on a negative edge
IEDG=1, transferred on a positive edge
- Bit 2 **ETO1 Enable Timer Overflow Interrupt**
When this bit is set, an internal interrupt (IRQ₁) is enabled for TO1. When cleared, the interrupt is inhibited.
- Bit 3 **EOC11 Enable Output Compare Interrupt 1**
When this bit is set, an internal interrupt (IRQ₃) is enabled for OCF1. When cleared, the interrupt is inhibited.
- Bit 4 **EIC1 Enable Input Capture Interrupt**
When this bit is set, an internal interrupt (IRQ₄) is enabled for ICF. When cleared, the interrupt is inhibited.
- Bit 5 **TOF Timer Overflow Flag**
This read only bit is set when the FCR contains all 1's. It is cleared by reading the TCSR1 followed by the FCR's high byte (\$0009).
- Bit 6 **OCF1 Output Compare Flag 1**
This read only bit is set when a match is found between the OCR1 and the FRC. It is cleared by writing to the OCR1 (\$000B or \$000C) followed by reading the TCSR1 or TCSR2.
- Bit 7 **ICF Input Capture Flag**
This read only bit is set to indicate a level transition defined by IEDG. It is cleared by reading the high byte (\$000D) of the ICR followed by the TCSR1 or TCSR2.

● **Timer Control/Status Register 2 (TCSR2) (\$000F)**

The Timer Control/Status Register 2 is a 7-bit register. All bits are readable while the lower 4 bits can be written. The upper 3 bits indicate the following timer's status.

- Bit 5 A match has been found between the FRC and the OCR2 (OCF2).
- Bit 6 The same flag as the OCF1 of the TCSR1.
- Bit 7 The same flag as the ICF of the TCSR1.

The followings are each bit descriptions.

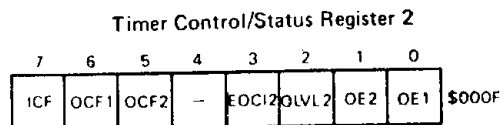

- Bit 0 **OE1 Output Enable 1**
If this bit is set, the OLVL1 will appear at Port 21 when a match is found between the FCR and the OCR1. When it is cleared, Port 21 will be I/O port. When set, it will be an output of OLVL1 automatically.
- Bit 1 **OE2 Output Enable 2**
If this bit is set, the OLVL2 will appear at Port 25 when a match between the FCR and the OCR2. When this bit is cleared, Port 25 will be I/O port. When set, it will be an output of OLVL2 automatically.

HD63701X0, HD637A01X0, HD637B01X0

Bit 2 OLVL2 Output Level 2

OLVL2 is transferred to Port 25 when a match is found between the FCR and the OCR2. If OE2, bit 5 of the TCSR2, is set, OLVL2 will appear at Port 25.

Bit 3 EOC12 Enable Output Compare Interrupt 2

When this bit is set, an internal interrupt (IRQ₂) is enabled for OCI2. When cleared, the interrupt is inhibited.

Bit 4 Not Used

Bit 5 OCF2 Output Compare Flag 2

This read-only bit is set when a match is found between the FCR and the OCR2. It is cleared by writing to the OCR2 (\$0019 or \$001A) followed by reading the TCSR2.

Bit 6 OCF1 Output Compare Flag 1

Bit 7 ICF Input Capture Flag

OCF1 and ICF addresses are partially decoded. CPU read of the TCSR1/TCSR2 makes it possible to read OCF1 and ICF into bit 6 and bit 7.

Both the TCSR1 and TCSR2 will be cleared by reset.

(Note) If OE1 or OE2 is set before the first output compare match is found after reset, Port 21 and Port 25 will output "0", respectively.

(Note) Because the set condition of ICF precedes its reset condition, ICF is not cleared when the set condition and the reset condition occur simultaneously. The same phenomenon applies to OCF1, OCF2 or TOF respectively.

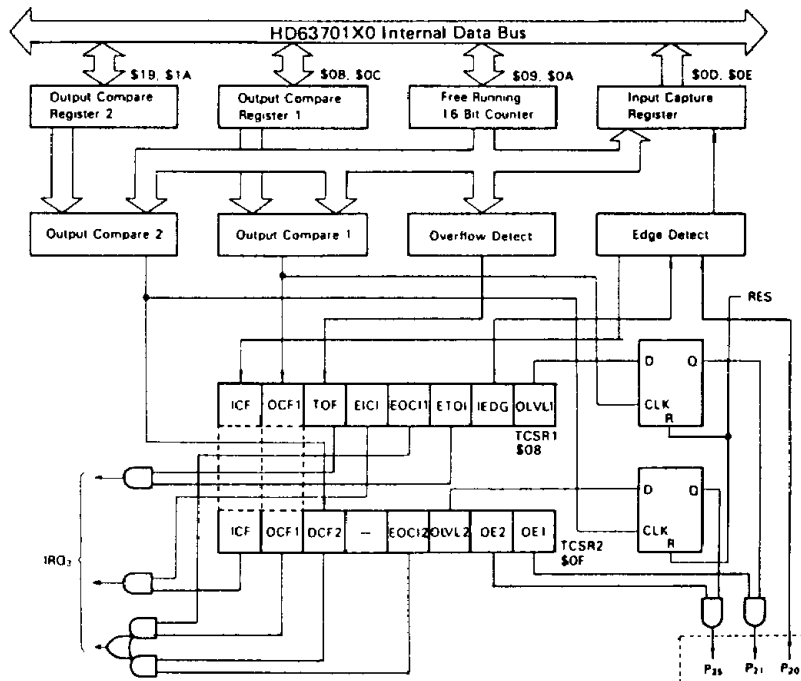

Figure 22 Timer 1 Block Diagram

■ **TIMER 2**

In addition to the timer 1, the HD63701X0 provides an 8-bit reloadable timer, which is capable of counting the external event. This timer 2 contains a timer output, so the MCU can generate three independent waveforms. (Refer to Fig. 23.)

The timer 2 is configured as follows:

- Control/Status Register 3 (7 bit)
- 8-bit Up Counter
- Time Constant Register (8 bit)

● **Timer 2 Up Counter (T2CNT) (\$001D)**

This is an 8-bit up counter which is incremented by the clock controlled by CKS0 and CKS1 of the TCSR3. The T2CNT is always readable without affecting itself. In addition, any value can be written to the T2CNT by software even during counting.

The counter is cleared when a match is found between the T2CNT and the TCONR or by reset.

A write to the T2CNT at the clear cycle does not reset it but

put the data to it.

● **Time Constant Register (TCONR) (\$001C)**

The Timer Constant Register is an 8-bit write only register. It is always compared with the T2CNT.

When a match has been found, counter match flag (CMF) of the Timer Control/Status Register 3 (TCSR3) is set and the value selected by TOS0 and TOS1 of the TCSR3 will appear at Port 26. When CMF is set, the FCR will be cleared simultaneously and then a counting starts from \$00. This enables regular interrupts and waveform outputs without any software support. The TCONR is set to "\$FF" by reset.

● **Timer Control/Status Register 3 (TCSR3) (\$001B)**

The Timer Control/Status Register 3 is a 7-bit register. All bits are readable while 6 bits except for CMF can be written.

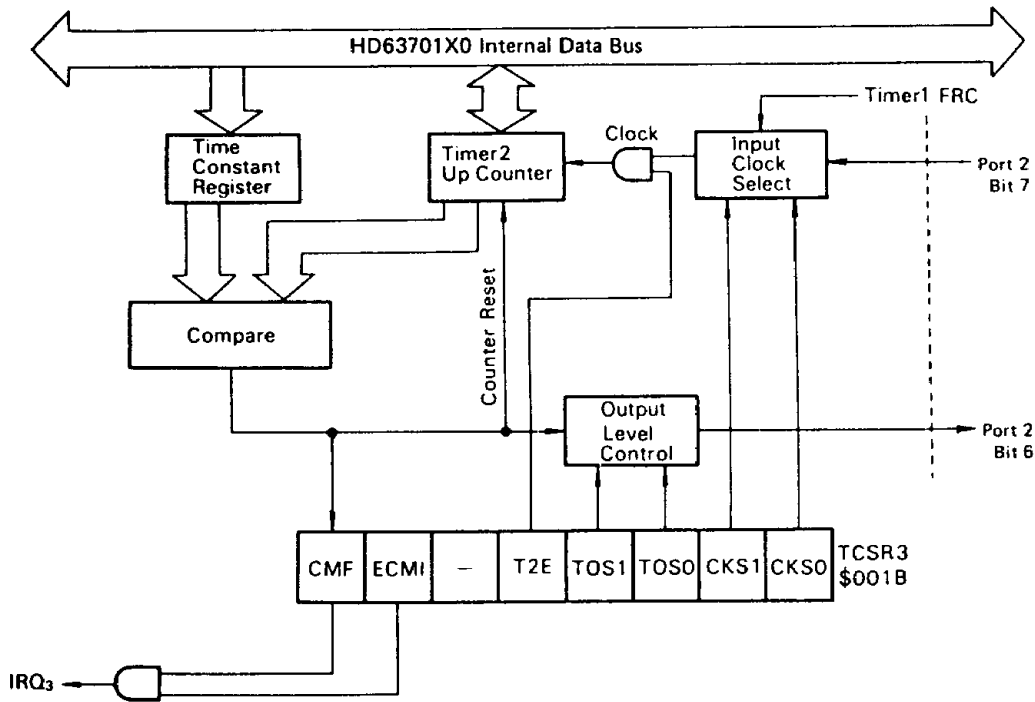
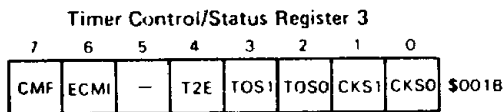

Figure 23 Timer 2 Block Diagram

The followings are each bit descriptions.



- Bit 0 CKS0 Input Clock Select 0
- Bit 1 CKS1 Input Clock Select 1

An input clock to the T2CNT is selected by these bits as shown in Table 7. When an external clock is selected, Port 27 will be an input automatically. The positive edge of the external clock increments the T2CNT. The maximum external clock is half of the system clock frequency.

Table 7 Input Clock Select

CKS1	CKS0	Input Clock to the Counter
0	0	E clock
0	1	E clock/8*
1	0	E clock/128*
1	1	External clock

* These clocks come from the FRC of the timer 1. If one of these clocks is selected as an input clock to the up counter, a write to the FRC of the timer 1 should be inhibited.

- Bit 2 TOS0 Timer Output Select 0
- Bit 3 TOS1 Timer Output Select 1

When a match is found between the T2CNT and the TCONR, timer 2 output selected by these bits shown in Table 8 will appear at Port 26. When both TOS0 and TOS1 are cleared, Port 26 will be an I/O port.

Table 8 Timer 2 Output Select

TOS1	TOS0	Timer Output
0	0	Timer Output Inhibited
0	1	Toggle Output*
1	0	Output "0"
1	1	Output "1"

* When a match is found between the T2CNT and the TCONR, timer 2 output level is reversed. This leads to production of a square wave with 50% duty to the external without any software support.

- Bit 4 T2E Timer 2 Enable Bit

When this bit is cleared, the T2CNT will stop. When set, a clock selected by CKS1 and CKS0 (Table 7) provides to the T2CNT.

(Note) P₂₆ is "0" when T2E is cleared and P₂₆ is configured as an output by TOS1 or TOS0. It also is "0" when T2E is set and P₂₆ is configured as an output before the first counter match.

- Bit 5 Not Used
- Bit 6 ECMI Enable Counter Match Interrupt

HD63701X0, HD637A01X0, HD637B01X0

When this bit is set, an internal interrupt (IRQ₂) is enabled for CMI. When cleared, the interrupt is inhibited.

Bit 7 CMF Counter Match Flag

This read only bit is set when a match is found between the T2CNT and the TCONR. It is cleared by writing "0". (It cannot be written "1" by software).

Each bit of the TCSR3 is cleared by reset.

■ SERIAL COMMUNICATION INTERFACE (SCI)

The HD63701X0 SCI provides two operation modes; one is an asynchronous mode by the NRZ format and the other is a clocked synchronous mode to transfer data synchronizing with the serial clock.

The serial interface is configured as follows:

- Transmit/Receive Control and Status Register (TRCSR)
- Rate/Mode Control Register (RMCR)
- Receive Data Register (RDR)
- Receive Data Shift Register (RDSR)
- Transmit Data Register (TDR)
- Transmit Data Shift Register (TDSR)

The SCI is initialized by software. The procedure is usually as follows:

- 1) Write a operation mode into each corresponding control bit of the RMCR.
- 2) Write a operation mode into each corresponding control bit of the TRCSR.

When setting the baud rate and operation mode, TE and RE should be "0". When TE and RE is set again, more than 1 bit cycle of the current baud rate is necessary. If set in less than 1 bit cycle, the SCI cannot be initialized occasionally.

● Asynchronous Mode

An asynchronous mode contains the following two data formats:

- 1 Start Bit + 8 Bit Data + 1 Stop Bit; 8 Bit Data Format
 - 1 Start Bit + 9 Bit Data + 1 Stop Bit; 9 Bit Data Format
- In 9 Bit Data Format, if the 9th bit is "1", the format of
- 1 Start Bit + 8 Bit Data + 2 Stop Bit

The SCI is initialized by writing desirable control bytes to the RMCR and then to the TRCSR.

The transmit operation is enabled by TE in the TRCSR. When TE is set, the output of the TDSR is connected to P₂₄ which will be configured as an output regardless of the DDR, and then the serial output is initiated by transmitting to a 10-bit preamble of "1" in the 8 Bit Data Format or an 11-bit preamble of "1" in the 9 Bit Data Format. Following the preamble, the internal synchronization is established and the transmitter section is ready for operation.

At this point one of two situation exist:

- 1) If the TDR is empty (TDRE=1), a continuous string of ones will be sent indicating an idle line.
- 2) If a byte has been written to the TDR (TDRE=0), it is transferred to the TDSR, TDRE will be set and transmission will begin.

During the transfer itself, the start bit (0) is first transmitted. Then the 8 data bits or the 9 data bits (beginning with bit 0) followed by the stop bit (1) are transmitted. When the TDR has been emptied, TDRE is set.

If the MCU fails to respond to the flag within the proper time, (TDRE is still set when the next normal transfer from the TDR to the TDSR should occur) then a "1" will be sent (instead of a "0") at start bit time, followed by more 1's until more data is supplied to the TDR. No 0's will be sent while TDRE remains as "1".

The receive operation is enabled by RE which configures P₂₃. The receive operation is controlled by the contents of the TRCSR and the RMCR. The receiver bit interval is divided into 8 sub-intervals for internal synchronization. The received bit stream is synchronized by the first "0" (space) encountered. The approximate center of each bit time is strobed during the next 10 bits.

If the tenth bit is not a "1" (stop bit), a framing error is assumed and ORFE is set. If the tenth bit is a "1", the data is transferred to the RDR and interrupt flag RDRF is set. If RDRF is still set at the next tenth bit time, ORFE will be set, indicating an over-run has occurred. When the CPU responds to either flag

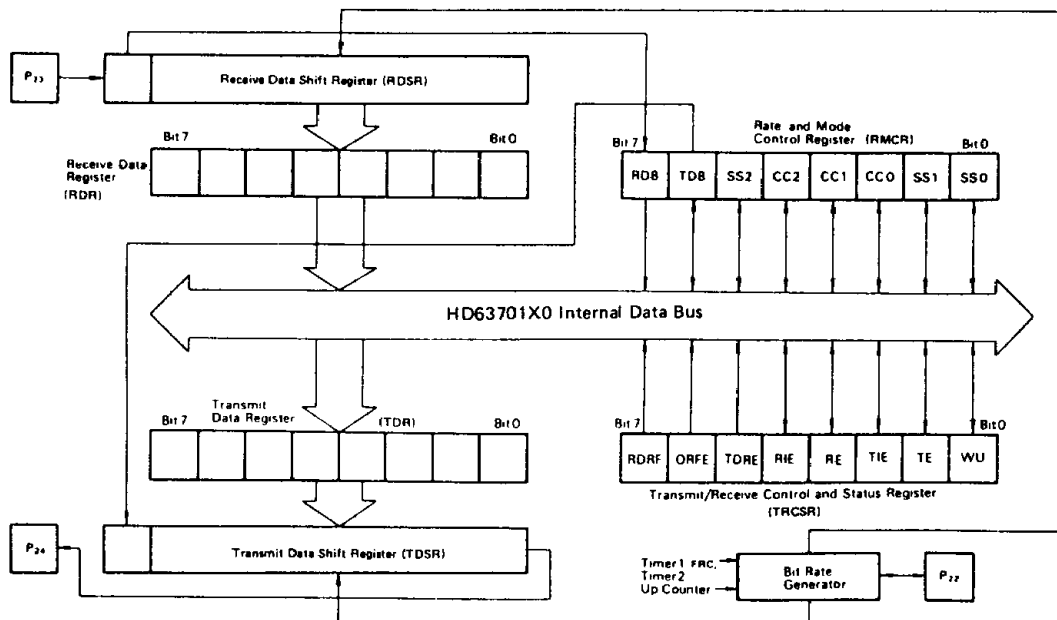

Figure 24 Serial Communication Interface Block Diagram



(RDRF or ORFE) by reading the TRCSR followed by reading the RDR, RDRF (or ORFE) will be cleared.

(Note) Clock Source in Asynchronous Mode

When using an internal clock for the SCI, the following requirements are applicable:

- Set CC1 and CC0 to "1" and "0" respectively.
- A clock is generated regardless of the value of TE, RE.
- The maximum clock rate is $E \div 16$.
- The output clock is the same as the bit rate.

When using an external clock for the SCI, the following requirements are applicable:

- Set CC1 and CC0 in the RMCR to "1" and "1" respectively.
- The external clock should be set 16 times the desired baud rate.
- the maximum clock frequency is the same as the system clock.

● Clocked Synchronous Mode

In the clocked synchronous mode, the transmit operation is synchronized with the clock pulse. In the clocked synchronous mode an SCI clock I/O pin is only P_{22} , so the receive and transmit operation cannot be simultaneously enabled. Therefore, TE and RE should not be set simultaneously. Fig. 25 gives a synchronous clock and a data format in the clocked synchronous mode.

The transmit operation is enabled by TE in the TRCSR. P_{24} is configured as an output regardless of the value of the corresponding DDR.

Both the RMCR and TRCSR should be set in the desirable operating conditions for data transmit.

If the user wishes to provide an external clock, the data bits (beginning with bit 0) are transmitted from P_{24} , synchronizing with 8 clock pulses supplied to P_{22} , when TDRE is "0". TDRE is set when the TDSR is "empty". More the 9th clock pulse is ignored.

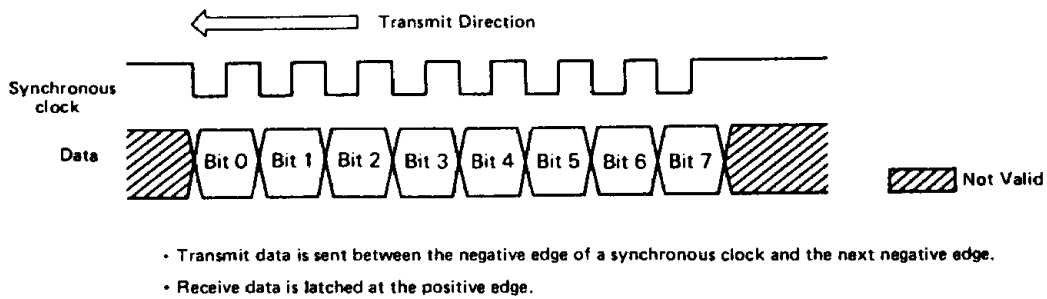

Figure 25 Clocked Synchronous Mode Format

The receive operation is enabled by RE. P_{22} is configured as an input for the 8 bit external clock and P_{23} is configured as an input for the receive data. The operating mode of data receive is decided by the TRCSR and the RMCR.

If the external clock is provided, RE should be set when P_{22} is "High". The receive data is transferred to the RDSR by this clock, and RDRF is set. More the 9th clock pulse are ignored. When RDRF is cleared by reading the RDR, the MCU starts receiving the next data.

RDRF, therefore, should be cleared with P_{22} "High". When the first byte data is received, RDRF is set. After the second byte, the receive operation is enabled by clearing RDRF.

● Transmit/Receive Control and Status Register (TRCSR) (\$0011)

The TRCSR is an 8 bit register which is readable. Bits 0 to 4 are also writable. This register is initialized to \$20 by reset. Each bit functions as follows.

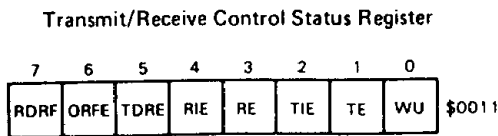

Bit 0 WU Wake-up

In a typical multi-processor configuration, the software protocol will usually identify the address at the beginning of the message. In order to permit uninterested MCU's to ignore the remaining message, a wake-up function is

available. By this, uninterested MCU can inhibit all further receive processing till the next message starts.

Then wake-up function is triggered by consecutive 1's with 1 frame length (10 bits for the 8-bit data format, or 11 bits for the 9-bit data format). The software protocol should provide the idle time between messages.

By setting this bit, the MCU stops data receive till the next message. The receive of consecutive "1" with one frame length wakes up and clears this bit and then the MCU restarts the receive operation. However, the RE flag should be set before setting this bit. In the clocked synchronous mode WU is not available, so this bit should not be set.

Bit 1 TE Transmit Enable

When this bit is set, transmit data will appear at P_{24} after one frame preamble in asynchronous mode, while in clocked synchronous mode appear immediately. This is executed regardless of the value of the corresponding DDR. When TE is cleared, the serial I/O doesn't affect P_{24} .

Bit 2 TIE Transmit Interrupt Enable

When this bit is set, an internal interrupt (IRQ_1) is enabled when TDRE (bit 5) is set. When cleared, the interrupt is inhibited.

Bit 3 RE Receive Enable

When set, P_{23} is configured as an input for the receive operation regardless of the value of the DDR. When RE is cleared, the serial I/O doesn't affect P_{23} .

Bit 4 RIE Receive Interrupt Enable

When this bit is set, an internal interrupt, IRQ_1 is enabled when RDRF (bit 7) or ORFE (bit 6) is set. When cleared, the interrupt is inhibited.

Bit 5 TDRE Transmit Data Register Empty

HD63701X0, HD637A01X0, HD637B01X0

TDRE is set when the TDR is transferred to the TDSR in the asynchronous mode, while it is set when the TDSR is "empty" in clocked synchronous mode. This bit is cleared by reading the TRCSR and writing the new transmit data to the TDR. TDRE is set by reset.

(Note) TE should be set before clearing TDRE.

Bit 6 ORFE Overrun Framing Error

ORFE is set when an overrun or a framing error is occurred (during data receive only). An overrun error occurs when a new receive data is ready to be transferred to the RDR with RDRF still set. A framing error occurs when a stop bit is "0". But in clocked synchronous mode, this bit is not affected. This bit is cleared when reading the TRCSR, then the RDR, or by reset.

Bit 7 RDRF Receive Data Register Full

RDRF is set when the RDSR is transferred to the RDR. Cleared when reading the TRCSR, then the RDR, or by reset.

(Note) When a few bits are set between bit 5 to bit 7 in the TRCSR, a read of the TRCSR is sufficient for clearing those bits. It is not necessary to read the TRCSR every-time to clear each bit.

● **Rate/Mode Control Register (RMCR)**

The RMCR controls the followings:

- Baud Rate
- Data Format
- Clock Source
- P₂₂ Function

In addition, if 9-bit data format is set in the asynchronous mode, the 9th bit is put in this register. All bits are readable and writable except bit 7 (read only). This register is cleared by reset.

These bits select the baud rate when using the internal clock. Table 9 lists the available bit times and baud rates. The timer 1's FRC (SS2=0) and the timer 2's up counter (SS2=1) provide

Rate/Mode Control Register

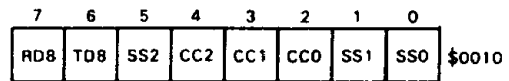

Bit 0 SS0 }
 Bit 1 SS1 } Speed Select
 Bit 5 SS2 }

the internal clock for the SCI. When the source of the SCI internal clock is the timer 2's up counter, the desired baud rates may be selected by the TCONR shown in Table 10.

(Note) When operating the SCI with internal clock, do not write to the counter which is the source of the SCI clock.

Bit 2 CC0 }
 Bit 3 CC1 } Clock Control/Format Select*
 Bit 4 CC2 }

These bits select the data format and the clock source (refer to Table 11).

- CC0, CC1 and CC2 are cleared and the MCU will be in the clocked synchronous mode (the external clock operation) by reset. Then P₂₂ is forced to be configured as an input for the clock. If using P₂₂ for an output, the DDR of port 2 should be set to "1" and CC1, CC0 must be set to "01".



HD63701X0, HD637A01X0, HD637B01X0

Table 9 SCI Bit Times and Rates

(1) Asynchronous Mode

SS2	SS1	SS0	XTAL	2.4576MHz	4.0MHz	4.9152MHz
			E	614.4kHz	1.0MHz	1.2288MHz
0	0	0	E ÷ 16	26 μs/38400Baud	16 μs/62500Baud	13 μs/76800Baud
0	0	1	E ÷ 128	208 μs/4800Baud	128 μs/7812.5Baud	104.2 μs/9600Baud
0	1	0	E ÷ 1024	1.67ms/600Baud	1.024ms/976.6Baud	833.3 μs/1200Baud
0	1	1	E ÷ 4096	6.67ms/150Baud	4.096ms/244.1Baud	3.333ms/300Baud
1	-	-	-	*	*	*

* When SS2 is "1", Timer 2 provides SCI clocks. The baud rate is shown as follows with the TCONR as N.

$$\text{Baud Rate} = \frac{f}{32(N+1)} \quad \left(\begin{array}{l} f: \text{input clock frequency to the} \\ \text{timer 2 counter} \\ N = 0 \sim 255 \end{array} \right)$$

(2) Clocked Synchronous Mode *

SS2	SS1	SS0	XTAL	4.0MHz	6.0MHz	8.0MHz
			E	1.0MHz	1.5MHz	2.0MHz
0	0	0	E ÷ 2	2 μs/bit	1.33 μs/bit	1 μs/bit
0	0	1	E ÷ 16	16 μs/bit	10.7 μs/bit	8 μs/bit
0	1	0	E ÷ 128	128 μs/bit	85.3 μs/bit	64 μs/bit
0	1	1	E ÷ 512	512 μs/bit	341 μs/bit	256 μs/bit
1	-	-	-	**	**	**

* Bit rates in the case of internal clock operation. In the case of external clock operation, the external clock is operatable up to DC ~ 1/2 system clock.

** The bit rate is shown as follows with the TCONR as N.

$$\text{Bit Rate } (\mu\text{s/bit}) = \frac{4(N+1)}{f} \quad \left(\begin{array}{l} f: \text{input clock frequency to the} \\ \text{timer 2 counter} \\ N = 0 \sim 255 \end{array} \right)$$

Table 10 Baud Rate and Time Constant Register Example

Baud Rate (Baud)	XTAL	2.4576MHz	3.6864MHz	4.0MHz	4.9152MHz	8.0MHz
110		21*	32*	35*	43*	70*
150		127	191	207	255	51*
300		63	95	103	127	207
600		31	47	51	63	103
1200		15	23	25	31	51
2400		7	11	12	15	25
4800		3	5	-	7	12
9600		1	2	-	3	-
19200		0	-	-	1	-
38400		-	-	-	0	-

* E/8 clock is provided to the timer 2's up counter.



HD63701X0, HD637A01X0, HD637B01X0

Table 11 SCI Format and Clock Source Control

CC2	CC1	CC0	Format	Mode	Clock Source	Port 2, Bit 2	Port 2, Bit 3	Port 2, Bit 4
0	0	0	8-bit data	Clocked Synchronous	External	Input	When RE is "1", bit 3 is used for a serial input.	
0	0	1	8-bit data	Asynchronous	Internal	Not Used**		
0	1	0	8-bit data	Asynchronous	Internal	Output*		
0	1	1	8-bit data	Asynchronous	External	Input		
1	0	0	8-bit data	Clocked Synchronous	Internal	Output	When TE is "1", bit 4 is used for a serial output.	
1	0	1	9-bit data	Asynchronous	Internal	Not Used**		
1	1	0	9-bit data	Asynchronous	Internal	Output*		
1	1	1	9-bit data	Asynchronous	External	Input		

* Clock output regardless of RE or TE in the TRCSR.

** Not used for the SCI.

Bit 6 TD8 Transmit Data Bit 8

When selecting the 9-bit data format in the asynchronous mode, this bit is transmitted as the 9th data.

Bit 7 RD8 Receive Data Bit 8

When selecting the 9-bit data format in the asynchronous mode, this bit stores the 9th bit data.

■ TIMER, SCI STATUS FLAG

Table 12 shows set and clear conditions of each status flag in the timer 1, the timer 2 and the SCI.

If the flag set and clear conditions occur at the same time, the

flag of the Timer 1 and the Timer 2 will be set, and the SCI cleared. Therefore the OCF1 and OCF2 of the Timer 1 may not be cleared correctly because set signal is generated periodically whenever the OCR matches the FRC. In order to clear these flags correctly, the match should be prohibited during the period between reading the TCSR and writing the OCR. For instance, these flags will be cleared correctly if the TCSR is read and the OCR is written continuously soon after matching the value of the OCR and the FCR.

Table 12 Timer 1, Timer 2 and SCI Status Flag

		Set Condition	Reset Condition
Timer 1	ICF	FRC → ICR by edge input to P ₂₀ .	1. Read the TCSR1 or TCSR2 then ICRH, when ICF = 1 2. \overline{RES} = 0
	OCF1	OCR1 = FRC	1. Read the TCSR1 or TCSR2 then write to the OCR1H or OCR1L, when OCF1 = 1 2. \overline{RES} = 0
	OCF2	OCR2 = FRC	1. Read the TCSR2 then write to the OCR2H or OCR2L, when OCF2 = 1 2. \overline{RES} = 0
	TOF	FRC = \$FFFF + 1 cycle	1. Read the TCSR1 then FRCH, when TOF = 1 2. \overline{RES} = 0
Timer 2	CMF	T2CNT = TCONR	1. Write "0" to CMF, when CMF = 1 2. \overline{RES} = 0
SCI	RDRF	Receive Shift Register → RDR	1. Read the TRCSR then RDR, when RDRF = 1 2. \overline{RES} = 0
	ORFE	1. Framing Error (Asynchronous Mode) Stop Bit = 0 2. Overrun Error (Asynchronous Mode) Receive Shift Register → RDR when RDRF = 1	1. Read the TRCSR then RDR, when ORFE = 1 2. \overline{RES} = 0
	TDRE	1. Asynchronous Mode TDR → Transmit Shift Register 2. Clocked Synchronous Mode Transmit Shift Register is "empty" 3. \overline{RES} = 0	Read the TRCSR then write to the TDR, when TDRE = 1 (Note) Clear TDRE after setting TE.

(Note) 1. → ; transfer

2. For example; "ICRH" means High byte of ICR.



■ LOW POWER DISSIPATION MODE

The HD63701X0 provides two low power dissipation modes: sleep and standby.

● Sleep Mode

The MCU will be in the sleep mode when SLP instruction is executed. In the sleep mode, the CPU stops and the registers' contents are retained. While the peripherals such as timers, SCI etc. continue their functions. The power dissipation of the sleep-condition is one fifth that of the operating condition.

The MCU returns from this mode by an interrupt, \overline{RES} or \overline{STBY} ; it will be reset by \overline{RES} and the standby mode by \overline{STBY} . When the CPU responds to an interrupt request, it cancels the sleep mode, returns to the operation mode and branches to the interrupt routine. When the CPU masks this interrupt, it cancels the sleep mode and executes the next instruction. However, for example if the timer 1 or 2 prohibits a timer interrupt, the CPU doesn't cancel the sleep mode because of no interrupt request.

This sleep mode is effective to reduce the power dissipation for a system with no need of the HD63701X0's consecutive op-

eration.

● Standby Mode

In MCU mode, the HD63701X0 stops and reset with \overline{STBY} "low". In this mode, the power dissipation is reduced conspicuously. All pins except for the power supply, \overline{STBY} and XTAL are detached from the MCU internally and will be the high impedance state.

While the contents of RAM is retained. The MCU returns from this mode by reset. The followings are typical usage of this mode.

Save the CPU information and SP contents on RAM by \overline{NMI} . Then disable the RAME bit of the RAM control register and set the \overline{STBY} PWR bit to go to the standby mode. If the \overline{STBY} PWR bit is still set at reset, that indicates the power is supplied to the MCU and RAM contents are retained properly. So system can restore itself by returning their pre-standby informations to the SP and the CPU. Fig. 26 depicts the timing at each pin with this example.

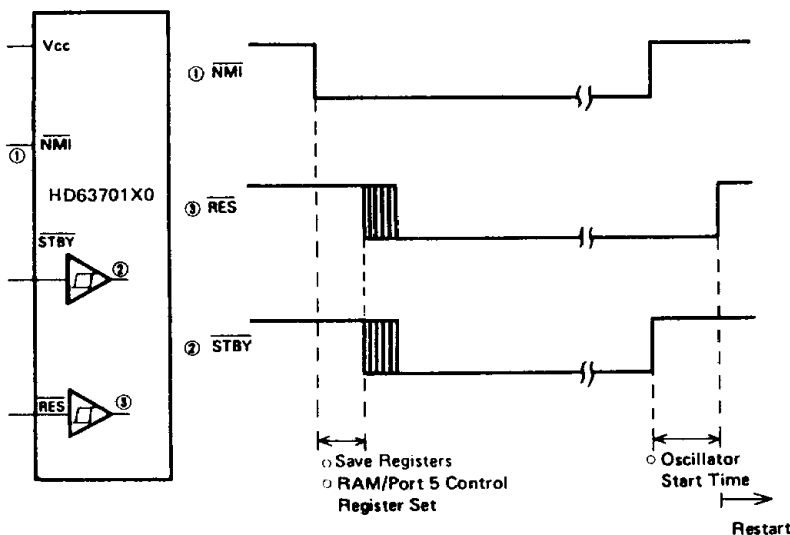

Figure 26 Standby Mode Timing

■ TRAP FUNCTION

The CPU generates an interrupt with the highest priority (TRAP) when fetching an undefined instruction or an instruction from non-memory space. The TRAP prevents the system-burst caused by noise or a program error.

● Op Code Error

When fetching an undefined op code, the CPU saves CPU registers as well as a normal interrupt and branches to the TRAP (\$FFEE, \$FFEF). This provides the priority next to reset.

● Address Error

When an instruction fetch is made excluding internal ROM, RAM and external memory area, the MCU generates an interrupt as well as an op code error. But on the system with no memory in its external memory area, this error processing is not applicable if an instruction fetch is made from the external non-memory area. Table 13 provides addresses where an address error occurs to each mode.

This processing is available only for an instruction fetch and is not applicable to the access of normal data read/write.

Table 13 Addresses Applicable to Address Errors

Mode	1	2	3
Address	\$0000 } \$001F	\$0000 } \$001F	\$0000 } \$003F \$0100 } \$FFFF

(Note) The TRAP interrupt provides a retry function differently from other interrupts. This is a program flow return to the address where the TRAP occurs when a sequence returns to a main routine from the TRAP interrupt routine by RTI. The retry can prevent the system burst caused by noise etc.

However, if another TRAP occurs, the program repeats the TRAP interrupt forever, so the consideration is necessary in programming.

Table 14 Accumulator, Memory Manipulation Instructions

Operations	Mnemonic	Addressing Modes												Boolean/ Arithmetic Operation	Condition Code Register								
		IMMED		DIRECT		INDEX		EXTEND		IMPLIED		5	4		3	2	1	0					
		OP	#	OP	#	OP	#	OP	#	OP	#												
Add	ADDA	8B	2	2	9B	3	2	AB	4	2	BB	4	3				A + M → A	1	•	1	1	1	1
	ADDB	CB	2	2	DB	3	2	EB	4	2	FB	4	3				B + M → B	1	•	1	1	1	1
Add Double	ADDD	C3	3	3	D3	4	2	E3	5	2	F3	5	3				A + B + M; M + 1 → A, B	•	•	1	1	1	1
Add Accumulators	ABA													1B	1	1	A + B → A	1	•	1	1	1	1
Add With Carry	ADCA	89	2	2	99	3	2	A9	4	2	B9	4	3				A + M + C → A	1	•	1	1	1	1
	ADCB	C9	2	2	D9	3	2	E9	4	2	F9	4	3				B + M + C → B	1	•	1	1	1	1
AND	ANDA	B4	2	2	94	3	2	A4	4	2	B4	4	3				A · M → A	•	•	1	1	R	•
	ANDB	C4	2	2	D4	3	2	E4	4	2	F4	4	3				B · M → B	•	•	1	1	R	•
Bit Test	BIT A	85	2	2	95	3	2	A5	4	2	B5	4	3				A · M	•	•	1	1	R	•
	BIT B	C5	2	2	D5	3	2	E5	4	2	F5	4	3				B · M	•	•	1	1	R	•
Clear	CLR							6F	5	2	7F	5	3				00 → M	•	•	R	S	R	R
	CLRA													4F	1	1	00 → A	•	•	R	S	R	R
	CLRB													5F	1	1	00 → B	•	•	R	S	R	R
Compare	CMPA	81	2	2	91	3	2	A1	4	2	B1	4	3				A - M	•	•	1	1	1	1
	CMPB	C1	2	2	D1	3	2	E1	4	2	F1	4	3				B - M	•	•	1	1	1	1
Compare Accumulators	CBA													11	1	1	A - B	•	•	1	1	1	1
Complement, 1's	COM							63	6	2	73	6	3				$\bar{M} - M$	•	•	1	1	R	S
	COMA													43	1	1	A → A	•	•	1	1	R	S
	COMB													53	1	1	B → B	•	•	1	1	R	S
Complement, 2's (Negate)	NEG							60	6	2	70	6	3				00 - M → M	•	•	1	1	(1)	(2)
	NEGA													40	1	1	00 - A → A	•	•	1	1	(1)	(2)
	NEGB													50	1	1	00 - B → B	•	•	1	1	(1)	(2)
Decimal Adjust, A	DAA													19	2	1	Converts binary add of BCD characters into BCD format	•	•	1	1	1	(3)
Decrement	DEC							6A	6	2	7A	6	3				M - 1 → M	•	•	1	1	(4)	•
	DECA													4A	1	1	A - 1 → A	•	•	1	1	(4)	•
	DECB													5A	1	1	B - 1 → B	•	•	1	1	(4)	•
Exclusive OR	EORA	88	2	2	98	3	2	A8	4	2	B8	4	3				A ⊕ M → A	•	•	1	1	R	•
	EORB	C8	2	2	D8	3	2	E8	4	2	F8	4	3				B ⊕ M → B	•	•	1	1	R	•
Increment	INC							6C	6	2	7C	6	3				M + 1 → M	•	•	1	1	(5)	•
	INCA													4C	1	1	A + 1 → A	•	•	1	1	(5)	•
	INCB													5C	1	1	B + 1 → B	•	•	1	1	(5)	•
Load Accumulator	LDAA	86	2	2	96	3	2	A6	4	2	B6	4	3				M → A	•	•	1	1	R	•
	LDAB	C6	2	2	D6	3	2	E6	4	2	F6	4	3				M → B	•	•	1	1	R	•
Load Double Accumulator	LDD	CC	3	3	DC	4	2	EC	5	2	FC	5	3				M + 1 → B, M → A	•	•	1	1	R	•
Multiply Unsigned	MUL													3D	7	1	A × B → A, B	•	•	•	•	•	(6)
OR, Inclusive	ORAA	8A	2	2	9A	3	2	AA	4	2	BA	4	3				A + M → A	•	•	1	1	R	•
	ORAB	CA	2	2	DA	3	2	EA	4	2	FA	4	3				B + M → B	•	•	1	1	R	•
Push Data	PSHA													36	4	1	A → M _{SP} , SP - 1 → SP	•	•	•	•	•	•
	PSHB													37	4	1	B → M _{SP} , SP - 1 → SP	•	•	•	•	•	•
Pull Data	PULA													32	3	1	SP + 1 → SP, M _{SP} → A	•	•	•	•	•	•
	PULB													33	3	1	SP + 1 → SP, M _{SP} → B	•	•	•	•	•	•
Rotate Left	ROL							69	6	2	79	6	3				M	•	•	1	1	(6)	1
	ROLA													49	1	1	A	•	•	1	1	(6)	1
	ROLB													59	1	1	B	•	•	1	1	(6)	1
Rotate Right	ROR							66	6	2	76	6	3				M	•	•	1	1	(6)	1
	RORA													46	1	1	A	•	•	1	1	(6)	1
	RORB													56	1	1	B	•	•	1	1	(6)	1

(Note) Condition Code Register will be explained in Note of Table 17.

(continued)



Table 14 Accumulator, Memory Manipulation Instructions

Operations	Mnemonic	Addressing Modes												Boolean/ Arithmetic Operation	Condition Code Register											
		IMMED		DIRECT		INDEX		EXTEND		IMPLIED		5	4		3	2	1	0								
		OP	~ #	OP	~ #	OP	~ #	OP	~ #	OP	~ #								H	I	N	Z	V	C		
Shift Left Arithmetic	ASL							68	6	2	7B	6	3	M		•	•	•	•	•	•					
	ASLA												48	1	1	A		•	•	•	•	•	•			
	ASLB													58	1	1	B		•	•	•	•	•	•		
Double Shift Left, Arithmetic	ASLD													05	1	1	C		•	•	•	•	•	•		
Shift Right Arithmetic	ASR							67	6	2	77	6	3	M		•	•	•	•	•	•					
	ASRA													47	1	1	A		•	•	•	•	•	•		
	ASRB													57	1	1	B		•	•	•	•	•	•		
Shift Right Logical	LSR							64	6	2	74	6	3	M		•	•	•	•	R	•					
	LSRA													44	1	1	A		•	•	•	•	R	•		
	LSRB													54	1	1	B		•	•	•	•	R	•		
Double Shift Right Logical	LSRD													04	1	1	C		•	•	•	•	R	•		
Store Accumulator	STAA			97	3	2	A7	4	2	B7	4	3		A → M	•	•	•	•	•	R	•					
	STAB			D7	3	2	E7	4	2	F7	4	3		B → M	•	•	•	•	•	•	R	•				
Store Double Accumulator	STD			DD	4	2	ED	5	2	FD	5	3		A → M B → M + 1	•	•	•	•	•	•	R	•				
Subtract	SUBA	80	2	2	90	3	2	A0	4	2	B0	4	3		A - M → A	•	•	•	•	•	•	•	•			
	SUBB	C0	2	2	D0	3	2	E0	4	2	F0	4	3		B - M → B	•	•	•	•	•	•	•	•			
Double Subtract	SUBD	83	3	3	93	4	2	A3	5	2	B3	5	3		A : B - M : M + 1 → A : B	•	•	•	•	•	•	•	•			
Subtract Accumulators	SBA													10	1	1		A - B → A	•	•	•	•	•	•		
Subtract With Carry	SBCA	82	2	2	92	3	2	A2	4	2	B2	4	3		A - M - C → A	•	•	•	•	•	•	•	•			
	SBCB	C2	2	2	D2	3	2	E2	4	2	F2	4	3		B - M - C → B	•	•	•	•	•	•	•	•			
Transfer Accumulators	TAB													16	1	1		A → B	•	•	•	•	•	R	•	
	TBA													17	1	1		B → A	•	•	•	•	•	•	R	•
Test Zero or Minus	TST							6D	4	2	7D	4	3		M - 00	•	•	•	•	•	•	R	R			
	TSTA													4D	1	1		A - 00	•	•	•	•	•	•	R	R
	TSTB													5D	1	1		B - 00	•	•	•	•	•	•	R	R
And Immediate	AIM			71	6	3	61	7	3									M-IMM → M	•	•	•	•	•	R	•	
OR Immediate	OIM			72	6	3	62	7	3									M+IMM → M	•	•	•	•	•	•	R	•
EOR Immediate	EIM			75	6	3	65	7	3									M⊕IMM → M	•	•	•	•	•	•	R	•
Test Immediate	TIM			7B	4	3	6B	5	3									M-IMM	•	•	•	•	•	•	R	•

(Note) Condition Code Register will be explained in Note of Table 17.

● Additional Instruction

In addition to the HD6801 instruction set, the HD63701X0 prepares the following new instructions.

AIM (M) · (IMM) → (M)

Executes "AND" operation to immediate data and the memory contents and stores its result in the memory.

OIM (M) + (IMM) → (M)

Executes "OR" operation to immediate data and the memory contents and stores its result in the memory.

EIM (M) ⊕ (IMM) → (M)

Executes "EOR" operation to immediate data and the memory contents and stores its result in the memory.

TIM (M) · (IMM)

Executes "AND" operation to immediate data and changes the relative flag of the condition code register.

These are 3-byte instructions; the first byte is op code, the second immediate data and the third address modifier.

XGDX (ACCD) ↔ (IX)

Exchanges the contents of accumulator and the index register.

SLP

Goes to the sleep mode. Refer to "LOW POWER DIS-SIPATION MODE" for more details of the sleep mode.

Table 15 Index Register, Stack Manipulation Instructions

Pointer Operations	Mnemonic	Addressing Modes										Boolean/ Arithmetic Operation	Condition Code Register						
		IMMED		DIRECT		INDEX		EXTEND		IMPLIED			Branch Test	5	4	3	2	1	0
		OP	~ #	OP	~ #	OP	~ #	OP	~ #	OP	~ #			H	I	N	Z	V	C
Compare Index Reg	CPX	BC	3 3	9C	4 2	AC	5 2	BC	5 3			X - M:M + 1	
Decrement Index Reg	DEX										09	1 1	X - 1 - X	
Decrement Stack Pntr	DES										34	1 1	SP - 1 - SP	
Increment Index Reg	INX										08	1 1	X + 1 - X	
Increment Stack Pntr	INS										31	1 1	SP + 1 - SP	
Load Index Reg	LDX	CE	3 3	0E	4 2	EE	5 2	FE	5 3			M - X _H , (M + 1) - X _L		
Load Stack Pntr	LDS	BE	3 3	9E	4 2	AE	5 2	BE	5 3			M - SP _H , (M + 1) - SP _L		
Store Index Reg	STX			0F	4 2	EF	5 2	FF	5 3			X _H - M, X _L - (M + 1)		
Store Stack Pntr	STS			9F	4 2	AF	5 2	BF	5 3			SP _H - M, SP _L - (M + 1)		
Index Reg → Stack Pntr	TXS										35	1 1	X - 1 - SP	
Stack Pntr → Index Reg	TSX										30	1 1	SP + 1 - X	
Add	ABX										3A	1 1	B + X - X	
Push Data	PSHX										3C	5 1	X _L - M _{sp} , SP - 1 - SP X _H - M _{sp} , SP - 1 - SP	
Pull Data	PULX										3B	4 1	SP + 1 - SP, M _{sp} - X _H SP + 1 - SP, M _{sp} - X _L	
Exchange	XGD X										18	2 1	ACCD ← IX	

(Note) Condition Code Register will be explained in Note of Table 17.

Table 16 Jump, Branch Instruction

Operations	Mnemonic	Addressing Modes										Branch Test	Condition Code Register						
		RELATIVE		DIRECT		INDEX		EXTEND		IMPLIED			Branch Test	5	4	3	2	1	0
		OP	~ #	OP	~ #	OP	~ #	OP	~ #	OP	~ #			H	I	N	Z	V	C
Branch Always	BRA	20	3 2									None	
Branch Never	BRN	21	3 2									None	
Branch If Carry Clear	BCC	24	3 2									C = 0	
Branch If Carry Set	BCS	25	3 2									C = 1	
Branch If = Zero	BEQ	27	3 2									Z = 1	
Branch If > Zero	BGE	2C	3 2									N ⊕ V = 0	
Branch If > Zero	BGT	2E	3 2									Z + (N ⊕ V) = 0	
Branch If Higher	BHI	22	3 2									C + Z = 0	
Branch If < Zero	BLE	2F	3 2									Z + (N ⊕ V) = 1	
Branch If Lower Or Same	BLS	23	3 2									C + Z = 1	
Branch If < Zero	BLT	2D	3 2									N ⊕ V = 1	
Branch If Minus	BMI	28	3 2									N = 1	
Branch If Not Equal Zero	BNE	26	3 2									Z = 0	
Branch If Overflow Clear	BVC	28	3 2									V = 0	
Branch If Overflow Set	BVS	29	3 2									V = 1	
Branch If Plus	BPL	2A	3 2									N = 0	
Branch To Subroutine	BSR	8D	5 2										
Jump	JMP					6E	3 2	7E	3 3				
Jump To Subroutine	JSR			9D	5 2	AD	5 2	BD	6 3				
No Operation	NOP										01	1 1	Advances Prog. Cntr. Only	
Return From Interrupt	RTI										38	10 1		
Return From Subroutine	RTS										39	5 1		
Software Interrupt	SWI										3F	12 1		
Wait for Interrupt*	WAI										3E	9 1		
Sleep	SLP										1A	4 1		

(Note) * WAI put R/W high; Address Bus goes to FFFF; Data Bus becomes tri-stated.
Condition Code Register will be explained in Note of Table 17.



Table 17 Condition Code Register Manipulation Instructions

Operations	Mnemonic	Addressing Modes			Boolean Operation	Condition Code Register								
		IMPLIED				5	4	3	2	1	0			
		OP	~	#								H	I	N
Clear Carry	CLC	0C	1	1	0 → C	•	•	•	•	•	•	•	•	R
Clear Interrupt Mask	CLI	0E	1	1	0 → I	•	R	•	•	•	•	•	•	•
Clear Overflow	CLV	0A	1	1	0 → V	•	•	•	•	•	R	•	•	•
Set Carry	SEC	0D	1	1	1 → C	•	•	•	•	•	•	•	•	S
Set Interrupt Mask	SEI	0F	1	1	1 → I	•	S	•	•	•	•	•	•	•
Set Overflow	SEV	0B	1	1	1 → V	•	•	•	•	•	•	S	•	•
Accumulator A → CCR	TAP	06	1	1	A → CCR	(10)								
CCR → Accumulator A	TPA	07	1	1	CCR → A	•	•	•	•	•	•	•	•	•

LEGEND

- OP Operation Code (Hexadecimal)
- ~ Number of MCU Cycles
- MSP Contents of memory location pointed to by Stack Pointer
- # Number of Program Bytes
- + Arithmetic Plus
- Arithmetic Minus
- Boolean AND
- + Boolean Inclusive OR
- ⊕ Boolean Exclusive OR
- M Complement of M
- Transfer into
- 0 Bit = Zero
- 00 Byte = Zero

CONDITION CODE SYMBOLS

- H Half-carry from bit 3 to bit 4
- I Interrupt mask
- N Negative (sign bit)
- Z Zero (byte)
- V Overflow, 2's complement
- C Carry/Borrow from/to bit 7
- R Reset Always
- S Set Always
- ↑ Set if true after test or clear
- Not Affected

(Note) Condition Code Register Notes: (Bit set if test is true and cleared otherwise)

- (1) (Bit V) Test: Result = 10000000?
- (2) (Bit C) Test: Result ≠ 00000000?
- (3) (Bit C) Test: BCD Character of high-order byte greater than 10? (Not cleared if previously set)
- (4) (Bit V) Test: Operand = 10000000 prior to execution?
- (5) (Bit V) Test: Operand = 01111111 prior to execution?
- (6) (Bit V) Test: Set equal to N⊕ C = 1 after the execution of instructions
- (7) (Bit N) Test: Result less than zero? (Bit 15=1)
- (8) (All Bit) Load Condition Code Register from Stack.
- (9) (Bit I) Set when interrupt occurs. If previously set, a Non-Maskable Interrupt is required to exist the wait state.
- (10) (All Bit) Set according to the contents of Accumulator A.
- (11) (Bit C) Result of Multiplication Bit 7=1? (ACCB)

Table 18 OP-Code Map

OP CODE					ACC A	ACC B	IND	EXT DIR	ACCA or SP				ACCB or X				
	HI	0000	0001	0010	0011	0100	0101	0110	0111	1000	1001	1010	1011	1100	1101	1110	1111
LO	0	1	2	3	4	5	6	7	8	9	A	B	C	D	E	F	
0000	0	SBA	BRA	TSX	NEG				SUB								
0001	1	NOP	CBA	BRN	INS	AIM				CMP							
0010	2			BHI	PULA	OIM				SBC							
0011	3			BLS	PULB	COM				SUBD				ADD			
0100	4	LSRD		BCC	DES	LSR				AND							
0101	5	ASLD		BCS	TXS	EIM				BIT							
0110	6	TAP	TAB	BNE	PSHA	ROR				LDA							
0111	7	TPA	TBA	BEQ	PSHB	ASR				STA				STA			
1000	8	INX	XGDX	BVC	PULX	ASL				EOR							
1001	9	DEX	DAA	BVS	RTS	ROL				ADC							
1010	A	CLV	SLP	BPL	ABX	DEC				ORA							
1011	B	SEV	ABA	BMI	RTI	TIM				ADD							
1100	C	CLC		BGE	PSHX	INC				CPX				LDD			
1101	D	SEC		BLT	MUL	TST				BSR				JSR			
1110	E	CLI		BGT	WAI	JMP				LDS				LDX			
1111	F	SEI		BLE	SWI	CLR				STS				STX			

UNDEFINED OP CODE

* Occurs only on each instruction of AIM, OIM, EIM, TIM



■ CPU OPERATION

● CPU Instruction Flow

When operating, the CPU fetches an instruction from a memory and executes the required functions. This sequence starts after the reset release and repeats itself limitlessly if not affected by a special instruction or a control signal. SWI, RTI, WAI and SLP instructions are to change this operation, while NMI, $\overline{IRQ_1}$, $\overline{IRQ_2}$, $\overline{IRQ_3}$, HALT and \overline{STBY} are to control it. Fig. 28 gives the CPU mode shift and Fig. 29 the CPU system flow-chart. Table 19 shows the CPU operating states and port states.

● Operation at Each Instruction Cycle

Table 20 provides the operation at each instruction cycle. By the pipeline control of the HD63701X0, MULT, PUL, DAA and XGD_X instructions etc. prefetch the next instruction. So attention is necessary to the counting of the instruction cycles because it is different from the existent one from op code fetch to the next instruction op code.

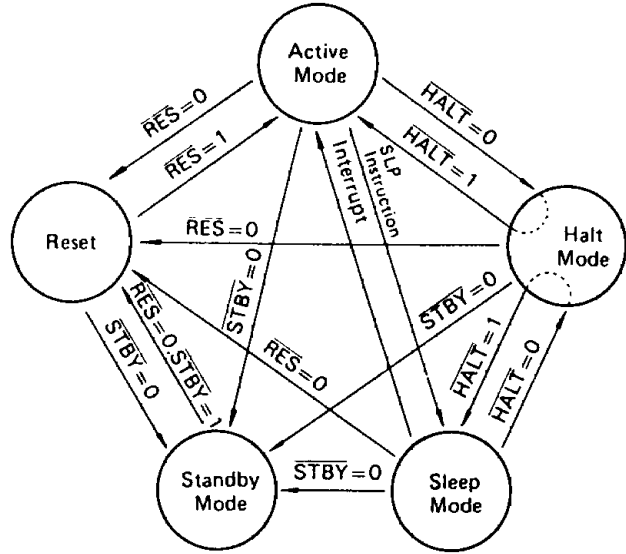

Figure 28 CPU Operation Mode Transition

Table 19 CPU Operation State and Port State

Port	Mode	Reset	STBY****	HALT***	Sleep
Port 1 (A ₀ ~ A ₇)	Mode 1, 2	H	T	T	H
	Mode 3	T		Keep	Keep
Port 2	Mode 1, 2	T	T	Keep	Keep
	Mode 3			Keep	Keep
Port 3 (D ₀ ~ D ₇)	Mode 1, 2	T	T	T	T
	Mode 3			Keep	Keep
Port 4 (A ₈ ~ A ₁₅)	Mode 1, 2	H	T	T	H
	Mode 3	T		Keep	Keep
Port 5	Mode 1, 2	T	T	T	T
	Mode 3			Keep	Keep
Port 6	Mode 1, 2	T	T	Keep	Keep
	Mode 3			Keep	Keep
Port 7	Mode 1, 2	•	T	••	•
	Mode 3	T		Keep	Keep

- H: High, L: Low, T: High Impedance
- \overline{RD} , \overline{WR} , R/W, \overline{LIR} =H, BA=L
- \overline{RD} , \overline{WR} , R/W=T, \overline{LIR} , BA=H
- HALT is unacceptable in mode 3.
- E pin goes to high impedance state.

Table 20 Cycle-by-Cycle Operation

Address Mode & Instructions		Cycles	Cycle #	Address Bus	R/W	\overline{RD}	WR	\overline{LIR}	Data Bus
IMMEDIATE									
ADC	ADD	2	1	Op Code Address + 1	1	0	1	1	Operand Data
AND	BIT		2	Op Code Address + 2	1	0	1	0	Next Op Code
CMP	EOR								
LDA	ORA								
SBC	SUB								
ADDD	CPX	3	1	Op Code Address + 1	1	0	1	1	Operand Data (MSB)
LDD	LDS		2	Op Code Address + 2	1	0	1	1	Operand Data (LSB)
LDX	SUBD		3	Op Code Address + 3	1	0	1	0	Next Op Code
DIRECT									
ADC	ADD	3	1	Op Code Address + 1	1	0	1	1	Address of Operand (LSB)
AND	BIT		2	Address of Operand	1	0	1	1	Operand Data
CMP	EOR		3	Op Code Address + 2	1	0	1	0	Next Op Code
LDA	ORA								
SBC	SUB								
STA		3	1	Op Code Address + 1	1	0	1	1	Destination Address
			2	Destination Address	0	1	0	1	Accumulator Data
			3	Op Code Address + 2	1	0	1	0	Next Op Code
ADDD	CPX	4	1	Op Code Address + 1	1	0	1	1	Address of Operand (LSB)
LDD	LDS		2	Address of Operand	1	0	1	1	Operand Data (MSB)
LDX	SUBD		3	Address of Operand + 1	1	0	1	1	Operand Data (LSB)
			4	Op Code Address + 2	1	0	1	0	Next Op Code
STD	STS	4	1	Op Code Address + 1	1	0	1	1	Destination Address (LSB)
STX			2	Destination Address	0	1	0	1	Register Data (MSB)
			3	Destination Address + 1	0	1	0	1	Register Data (LSB)
			4	Op Code Address + 2	1	0	1	0	Next Op Code
JSR		5	1	Op Code Address + 1	1	0	1	1	Jump Address (LSB)
			2	FFFF	1	1	1	1	Restart Address (LSB)
			3	Stack Pointer	0	1	0	1	Return Address (LSB)
			4	Stack Pointer - 1	0	1	0	1	Return Address (MSB)
			5	Jump Address	1	0	1	0	First Subroutine Op Code
TIM		4	1	Op Code Address + 1	1	0	1	1	Immediate Data
			2	Op Code Address + 2	1	0	1	1	Address of Operand (LSB)
			3	Address of Operand	1	0	1	1	Operand Data
			4	Op Code Address + 3	1	0	1	0	Next Op Code
AIM	EIM	6	1	Op Code Address + 1	1	0	1	1	Immediate Data
OIM			2	Op Code Address + 2	1	0	1	1	Address of Operand (LSB)
			3	Address of Operand	1	0	1	1	Operand Data
			4	FFFF	1	1	1	1	Restart Address (LSB)
			5	Address of Operand	0	1	0	1	New Operand Data
			6	Op Code Address + 3	1	0	1	0	Next Op Code

(Continued)

HD63701X0, HD637A01X0, HD637B01X0

Address Mode & Instructions	Cycles	Cycle #	Address Bus	R/W	RD	WR	LIR	Data Bus
INDEXED								
JMP	3	1	Op Code Address + 1	1	0	1	1	Offset
		2	FFFF	1	1	1	1	Restart Address (LSB)
		3	Jump Address	1	0	1	0	First Op Code of Jump Routine
ADC ADD AND BIT CMP EOR LDA ORA SBC SUB TST	4	1	Op Code Address + 1	1	0	1	1	Offset
		2	FFFF	1	1	1	1	Restart Address (LSB)
		3	IX + Offset	1	0	1	1	Operand Data
		4	Op Code Address + 2	1	0	1	0	Next Op Code
STA	4	1	Op Code Address + 1	1	0	1	1	Offset
		2	FFFF	1	1	1	1	Restart Address (LSB)
		3	IX + Offset	0	1	0	1	Accumulator Data
		4	Op Code Address + 2	1	0	1	0	Next Op Code
ADD CPX LDD LDS LDX SUBD	5	1	Op Code Address + 1	1	0	1	1	Offset
		2	FFFF	1	1	1	1	Restart Address (LSB)
		3	IX + Offset	1	0	1	1	Operand Data (MSB)
		4	IX + Offset + 1	1	0	1	1	Operand Data (LSB)
		5	Op Code Address + 2	1	0	1	0	Next Op Code
STD STS STX	5	1	Op Code Address + 1	1	0	1	1	Offset
		2	FFFF	1	1	1	1	Restart Address (LSB)
		3	IX + Offset	0	1	0	1	Register Data (MSB)
		4	IX + Offset + 1	0	1	0	1	Register Data (LSB)
		5	Op Code Address + 2	1	0	1	0	Next Op Code
JSR	5	1	Op Code Address + 1	1	0	1	1	Offset
		2	FFFF	1	1	1	1	Restart Address (LSB)
		3	Stack Pointer	0	1	0	1	Return Address (LSB)
		4	Stack Pointer - 1	0	1	0	1	Return Address (MSB)
		5	IX + Offset	1	0	1	0	First Subroutine Op Code
ASL ASR COM DEC INC LSR NEG ROL ROR	6	1	Op Code Address + 1	1	0	1	1	Offset
		2	FFFF	1	1	1	1	Restart Address (LSB)
		3	IX + Offset	1	0	1	1	Operand Data
		4	FFFF	1	1	1	1	Restart Address (LSB)
		5	IX + Offset	0	1	0	1	New Operand Data
		6	Op Code Address + 1	1	0	1	0	Next Op Code
TIM	5	1	Op Code Address + 1	1	0	1	1	Immediate Data
		2	Op Code Address + 2	1	0	1	1	Offset
		3	FFFF	1	1	1	1	Restart Address (LSB)
		4	IX + Offset	1	0	1	1	Operand Data
		5	Op Code Address + 3	1	0	1	0	Next Op Code
CLR	5	1	Op Code Address + 1	1	0	1	1	Offset
		2	FFFF	1	1	1	1	Restart Address (LSB)
		3	IX + Offset	1	0	1	1	Operand Data
		4	IX + Offset	0	1	0	1	00
		5	Op Code Address + 2	1	0	1	0	Next Op Code
AIM EIM OIM	7	1	Op Code Address + 1	1	0	1	1	Immediate Data
		2	Op Code Address + 2	1	0	1	1	Offset
		3	FFFF	1	1	1	1	Restart Address (LSB)
		4	IX + Offset	1	0	1	1	Operand Data
		5	FFFF	1	1	1	1	Restart Address (LSB)
		6	IX + Offset	0	1	0	1	New Operand Data
		7	Op Code Address + 3	1	0	1	0	Next Op Code

(Continued)



HD63701X0, HD637A01X0, HD637B01X0

Address Mode & Instructions	Cycles	Cycle #	Address Bus	R/W	RD	WR	LTR	Data Bus
EXTEND								
JMP	3	1	Op Code Address + 1	1	0	1	1	Jump Address (MSB)
		2	Op Code Address + 2	1	0	1	1	Jump Address (LSB)
		3	Jump Address	1	0	1	0	Next Op Code
ADC ADD TST	4	1	Op Code Address + 1	1	0	1	1	Address of Operand (MSB)
AND BIT		2	Op Code Address + 2	1	0	1	1	Address of Operand (LSB)
CMP EOR		3	Address of Operand	1	0	1	1	Operand Data
LDA ORA SBC SUB		4	Op Code Address + 3	1	0	1	0	Next Op Code
STA	4	1	Op Code Address + 1	1	0	1	1	Destination Address (MSB)
		2	Op Code Address + 2	1	0	1	1	Destination Address (LSB)
		3	Destination Address	0	1	0	1	Accumulator Data
		4	Op Code Address + 3	1	0	1	0	Next Op Code
ADDD	5	1	Op Code Address + 1	1	0	1	1	Address of Operand (MSB)
CPX LDD		2	Op Code Address + 2	1	0	1	1	Address of Operand (LSB)
LDS LDX		3	Address of Operand	1	0	1	1	Operand Data (MSB)
SUBD		4	Address of Operand + 1	1	0	1	1	Operand Data (LSB)
		5	Op Code Address + 3	1	0	1	0	Next Op Code
STD STS	5	1	Op Code Address + 1	1	0	1	1	Destination Address (MSB)
STX		2	Op Code Address + 2	1	0	1	1	Destination Address (LSB)
		3	Destination Address	0	1	0	1	Register Data (MSB)
		4	Destination Address + 1	0	1	0	1	Register Data (LSB)
		5	Op Code Address + 3	1	0	1	0	Next Op Code
JSR	6	1	Op Code Address + 1	1	0	1	1	Jump Address (MSB)
		2	Op Code Address + 2	1	0	1	1	Jump Address (LSB)
		3	FFFF	1	1	1	1	Restart Address (LSB)
		4	Stack Pointer	0	1	0	1	Return Address (LSB)
		5	Stack Pointer - 1	0	1	0	1	Return Address (MSB)
		6	Jump Address	1	0	1	0	First Subroutine Op Code
ASL ASR	6	1	Op Code Address + 1	1	0	1	1	Address of Operand (MSB)
COM DEC		2	Op Code Address + 2	1	0	1	1	Address of Operand (LSB)
INC LSR		3	Address of Operand	1	0	1	1	Operand Data
NEG ROL		4	FFFF	1	1	1	1	Restart Address (LSB)
ROR		5	Address of Operand	0	1	0	1	New Operand Data
		6	Op Code Address + 3	1	0	1	0	Next Op Code
CLR	5	1	Op Code Address + 1	1	0	1	1	Address of Operand (MSB)
		2	Op Code Address + 2	1	0	1	1	Address of Operand (LSB)
		3	Address of Operand	1	0	1	1	Operand Data
		4	Address of Operand	0	1	0	1	00
		5	Op Code Address + 3	1	0	1	0	Next Op Code

(Continued)

HD63701X0, HD637A01X0, HD637B01X0

Address Mode & Instructions		Cycles	Cycle #	Address Bus	R/W	\overline{RD}	\overline{WR}	\overline{LIR}	Data Bus
IMPLIED									
ABA	ABX		1	Op Code Address + 1	1	0	1	0	Next Op Code
ASL	ASLD								
ASR	CBA								
CLC	CLI								
CLR	CLV								
COM	DEC								
DES	DEX								
INC	INS								
INX	LSR	1							
LSRD	ROL								
ROR	NOP								
SBA	SEC								
SEI	SEV								
TAB	TAP								
TBA	TPA								
TST	TSX								
TXS									
DAA	XGDX	2	1	Op Code Address + 1	1	0	1	0	Next Op Code
			2	FFFF	1	1	1	1	Restart Address (LSB)
PULA	PULB		1	Op Code Address + 1	1	0	1	0	Next Op Code
		3	2	FFFF	1	1	1	1	Restart Address (LSB)
			3	Stack Pointer + 1	1	0	1	1	Data from Stack
PSHA	PSHB		1	Op Code Address + 1	1	0	1	1	Next Op Code
		4	2	FFFF	1	1	1	1	Restart Address (LSB)
			3	Stack Pointer	0	1	0	1	Accumulator Data
			4	Op Code Address + 1	1	0	1	0	Next Op Code
PULX			1	Op Code Address + 1	1	0	1	0	Next Op Code
		4	2	FFFF	1	1	1	1	Restart Address (LSB)
			3	Stack Pointer + 1	1	0	1	1	Data from Stack (MSB)
			4	Stack Pointer + 2	1	0	1	1	Data from Stack (LSB)
PSHX			1	Op Code Address + 1	1	0	1	1	Next Op Code
		5	2	FFFF	1	1	1	1	Restart Address (LSB)
			3	Stack Pointer	0	1	0	1	Index Register (LSB)
			4	Stack Pointer - 1	0	1	0	1	Index Register (MSB)
			5	Op Code Address + 1	1	0	1	0	Next Op Code
RTS			1	Op Code Address + 1	1	0	1	1	Next Op Code
		5	2	FFFF	1	1	1	1	Restart Address (LSB)
			3	Stack Pointer + 1	1	0	1	1	Return Address (MSB)
			4	Stack Pointer + 2	1	0	1	1	Return Address (LSB)
			5	Return Address	1	0	1	0	First Op Code of Return Routine
MUL			1	Op Code Address + 1	1	0	1	0	Next Op Code
		7	2	FFFF	1	1	1	1	Restart Address (LSB)
			3	FFFF	1	1	1	1	Restart Address (LSB)
			4	FFFF	1	1	1	1	Restart Address (LSB)
			5	FFFF	1	1	1	1	Restart Address (LSB)
			6	FFFF	1	1	1	1	Restart Address (LSB)
			7	FFFF	1	1	1	1	Restart Address (LSB)

(Continued)



HD63701X0, HD637A01X0, HD637B01X0

Address Mode & Instructions	Cycles	Cycle #	Address Bus	R/W	RD	WR	LIR	Data Bus
IMPLIED								
WAI	9	1	Op Code Address + 1	1	0	1	1	Next Op Code
		2	FFFF	1	1	1	1	Restart Address (LSB)
		3	Stack Pointer	0	1	0	1	Return Address (LSB)
		4	Stack Pointer - 1	0	1	0	1	Return Address (MSB)
		5	Stack Pointer - 2	0	1	0	1	Index Register (LSB)
		6	Stack Pointer - 3	0	1	0	1	Index Register (MSB)
		7	Stack Pointer - 4	0	1	0	1	Accumulator A
		8	Stack Pointer - 5	0	1	0	1	Accumulator B
		9	Stack Pointer - 6	0	1	0	1	Conditional Code Register
RTI	10	1	Op Code Address + 1	1	0	1	1	Next Op Code
		2	FFFF	1	1	1	1	Restart Address (LSB)
		3	Stack Pointer + 1	1	0	1	1	Conditional Code Register
		4	Stack Pointer + 2	1	0	1	1	Accumulator B
		5	Stack Pointer + 3	1	0	1	1	Accumulator A
		6	Stack Pointer + 4	1	0	1	1	Index Register (MSB)
		7	Stack Pointer + 5	1	0	1	1	Index Register (LSB)
		8	Stack Pointer + 6	1	0	1	1	Return Address (MSB)
		9	Stack Pointer + 7	1	0	1	1	Return Address (LSB)
		10	Return Address	1	0	1	0	First Op Code of Return Routine
SWI	12	1	Op Code Address + 1	1	0	1	1	Next Op Code
		2	FFFF	1	1	1	1	Restart Address (LSB)
		3	Stack Pointer	0	1	0	1	Return Address (LSB)
		4	Stack Pointer - 1	0	1	0	1	Return Address (MSB)
		5	Stack Pointer - 2	0	1	0	1	Index Register (LSB)
		6	Stack Pointer - 3	0	1	0	1	Index Register (MSB)
		7	Stack Pointer - 4	0	1	0	1	Accumulator A
		8	Stack Pointer - 5	0	1	0	1	Accumulator B
		9	Stack Pointer - 6	0	1	0	1	Conditional Code Register
		10	Vector Address FFFA	1	0	1	1	Address of SWI Routine (MSB)
		11	Vector Address FFFB	1	0	1	1	Address of SWI Routine (LSB)
		12	Address of SWI Routine	1	0	1	0	First Op Code of SWI Routine
SLP	4	1	Op Code Address + 1	1	0	1	1	Next Op Code
		2	FFFF	1	1	1	1	Restart Address (LSB)
		3	FFFF	1	1	1	1	Restart Address (LSB)
		4	Op Code Address + 1	1	0	1	0	Next Op Code
RELATIVE								
BCC BCS BEQ BGE BGT BHI BLE BLS BLT BMT BNE BPL BRA BRN BVC BVS	3	1	Op Code Address + 1	1	0	1	1	Branch Offset
		2	FFFF	1	1	1	1	Restart Address (LSB)
		3	Branch Address - Test = "1" Op Code Address + 1 - Test = "0"	1	0	1	0	First Op Code of Branch Routine Next Op Code
		4						
		5						
BSR	5	1	Op Code Address + 1	1	0	1	1	Offset
		2	FFFF	1	1	1	1	Restart Address (LSB)
		3	Stack Pointer	0	1	0	1	Return Address (LSB)
		4	Stack Pointer - 1	0	1	0	1	Return Address (MSB)
		5	Branch Address	1	0	1	0	First Op Code of Subroutine



HD63701X0, HD637A01X0, HD637B01X0

■ DIFFERENCES BETWEEN HD63701X0 AND HD6301X0

Item	HD63701X0	HD6301X0																								
V_{PP}/\overline{OE} pin function	V_{PP}/\overline{OE} MCU mode; Connected to V_{SS} voltage PROM mode; Input for the programming voltage	V_{SS} Connected to V_{SS} Voltage																								
Input capacitance	V_{PP}/\overline{OE} , 25pF max All other inputs, 12.5pF max	All inputs, 12.5pF max																								
Input high voltage of MP_0, MP_1	$V_{IH} = V_{SS} - 0.5V$ min	$V_{IH} = 2.0V$ min																								
Bus Timing	<table border="1"> <thead> <tr> <th></th> <th>HD63701X0</th> <th>HD637A01X0</th> <th>HD637B01X0</th> </tr> </thead> <tbody> <tr> <td>t_{AH}</td> <td>70</td> <td>45</td> <td>30</td> </tr> <tr> <td>t_{HW}</td> <td>70</td> <td>50</td> <td>35</td> </tr> </tbody> </table> <p style="text-align: right;">Unit: ns</p>		HD63701X0	HD637A01X0	HD637B01X0	t_{AH}	70	45	30	t_{HW}	70	50	35	<table border="1"> <thead> <tr> <th></th> <th>HD6301X0</th> <th>HD63A01X0</th> <th>HD63B01X0</th> </tr> </thead> <tbody> <tr> <td>t_{AH}</td> <td>80</td> <td>50</td> <td>35</td> </tr> <tr> <td>t_{HW}</td> <td>80</td> <td>50</td> <td>40</td> </tr> </tbody> </table> <p style="text-align: right;">Unit: ns</p>		HD6301X0	HD63A01X0	HD63B01X0	t_{AH}	80	50	35	t_{HW}	80	50	40
	HD63701X0	HD637A01X0	HD637B01X0																							
t_{AH}	70	45	30																							
t_{HW}	70	50	35																							
	HD6301X0	HD63A01X0	HD63B01X0																							
t_{AH}	80	50	35																							
t_{HW}	80	50	40																							
Crystal oscillator characteristics	Internal resistance of crystal oscillator R_S <table border="1"> <thead> <tr> <th>Frequency (MHz)</th> <th>2.5</th> <th>4.0</th> <th>6.0</th> <th>8.0</th> </tr> </thead> <tbody> <tr> <td>R_S max (Ω)</td> <td>500</td> <td>120</td> <td>80</td> <td>60</td> </tr> </tbody> </table>	Frequency (MHz)	2.5	4.0	6.0	8.0	R_S max (Ω)	500	120	80	60	Internal resistance of crystal oscillator R_S $R_S = 60\Omega$ max														
Frequency (MHz)	2.5	4.0	6.0	8.0																						
R_S max (Ω)	500	120	80	60																						
Storage temperature	$T_{stg} = -55$ to $125^\circ C$	$T_{stg} = -55$ to $150^\circ C$																								
Caution	The HD63701X0 differs from HD6301X0 in chip design and manufacturing process. When applying the HD63701X0 system to HD6301X0, and HD6301X0 system to HD63701X0, note that characteristic values are not exactly the same even if guaranteed values are the same.																									

■ PRECAUTION TO THE BOARD DESIGN OF OSCILLATION CIRCUIT

As shown in Fig. 30, there is a case that the cross talk disturbs the normal oscillation if signal lines are put near the oscillation circuit. When designing a board, pay attention to this. Crystal and C_L must be put as near the HD63701X0 as possible.

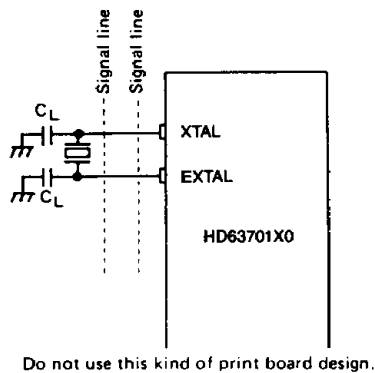

Figure 30 Precaution to the board design of oscillation circuit

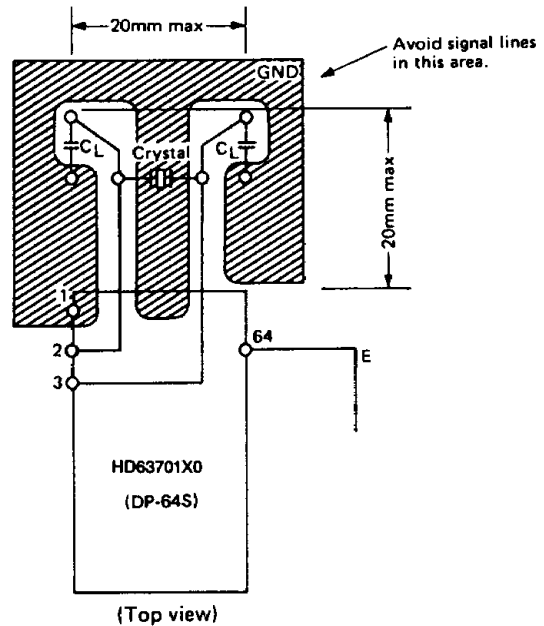

Figure 31 Example of Oscillation Circuits in Board Design

RECEIVE MARGIN OF THE SCI

Receive margin of the SCI contained in the HD63701X0 shown in Table 21.

Note: SCI=Serial Communication Interface

Table 21

Bit distortion tolerance ($t-t_0$) / t_0	Character distortion tolerance ($T-T_0$) / T_0
$\pm 43.7\%$	$\pm 4.37\%$

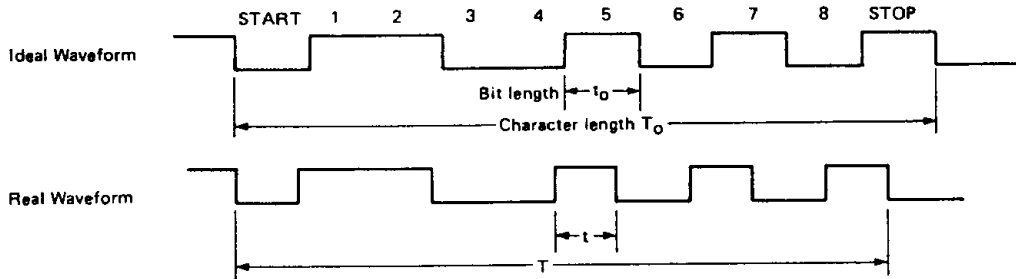

WARNING CONCERNING WAI INSTRUCTION

If the HALT signal is accepted by the MCU while the WAI instruction is executing, the CPU will not operate correctly after HALT mode is canceled.

WAI is a instruction which waits for an interrupt. The corresponding interrupt routine is executed after an interrupt occurs.

However, during the execution of the WAI instruction, HALT input makes the CPU malfunction and fetch an abnormal interrupt vectoring address.

In HALT mode, the CPU operates correctly without the WAI instruction and WAI is executed correctly without HALT input. Therefore, if HALT input is necessary, make interrupts wait during the loop routine, as shown in Figure 32.

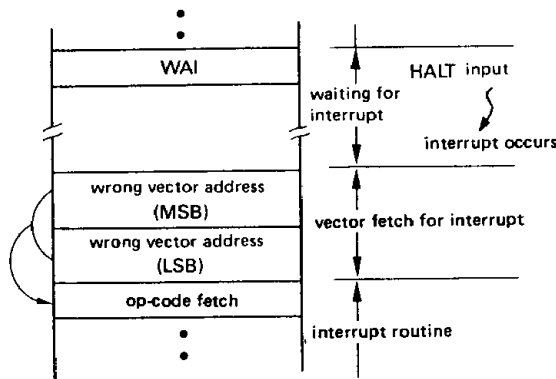

Figure 32 MAC function during WAI

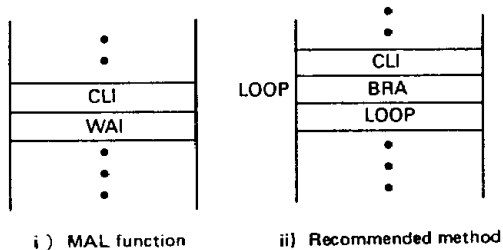

Figure 33 Program to wait for interrupt

WARNING CONCERNING POWER START-UP

RES must be held low for at least 20 ms when the power starts up. In this case, the internal reset function is not effective until the oscillation begins at power-on. The RES signal is input to the LSI in synchronism with the internal clock (shown in Figure 33).

Therefore, after power starts up, the LSI conditions such as its I/O ports and operating mode, are unstable. Fix the level of I/O ports by means of an external circuit to determine the level for system operation during the oscillator stabilization time.

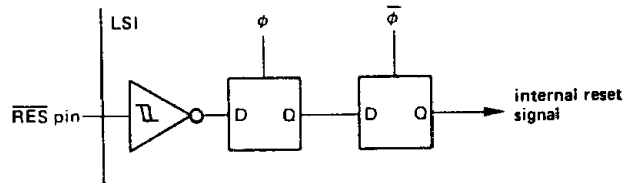

Figure 33 RES circuit

WRITE-ONLY REGISTER

When the CPU reads a write-only register, the read data is always \$FF, regardless of the value in the write-only register. Therefore, be careful of the results of instructions which read write-only register and perform an arithmetic or logical operation on its contents, such as AIM, ADD, or ROL, is executed, because the arithmetic or logical operation is always done with the data \$FF. In particulars, don't use the AIM, OIM or EIM instruction to manipulate the DDR bit of PORT.