

# HA13702A

Preliminary

## IPIC\* High Side Bulb Driver

### Description

\*(IPIC: Intelligent Power IC)

HA13702A is high side power driver IC with protectors and diagnostic function. The device is especially designed to switch automotive light bulbs using PWM current limiter system.

### Functions

- Power MOS source follower output (4 A)
- With over voltage shut down circuit (OVSD)
- With over current protector circuit (PWM OCL)
- With over temperature shut down circuit (OTSD)
- With diagnostic circuit and status output
- With fail safe function under input open circuit condition
- With low voltage inhibit circuit (LVI)
- With output negative voltage clamp circuit

### Features

- Protected against 60 V load dump condition
- Low  $R_{ON}$  (0.1  $\Omega$  typ)
- Wide operating supply voltage range ( $V_{DD} = 7$  V to 25 V)
- Protected against reverse supply voltage ( $-13$  V)
- Protected against output short circuit condition
- Suitable switching speed to have high speed operation and low EMI
- Input compatible with TTL, LS-TTL, or 5 V CMOS
- Protected against electrostatic discharge (2 kV min at 100 pF/1.5 k $\Omega$ )

### Block Diagram

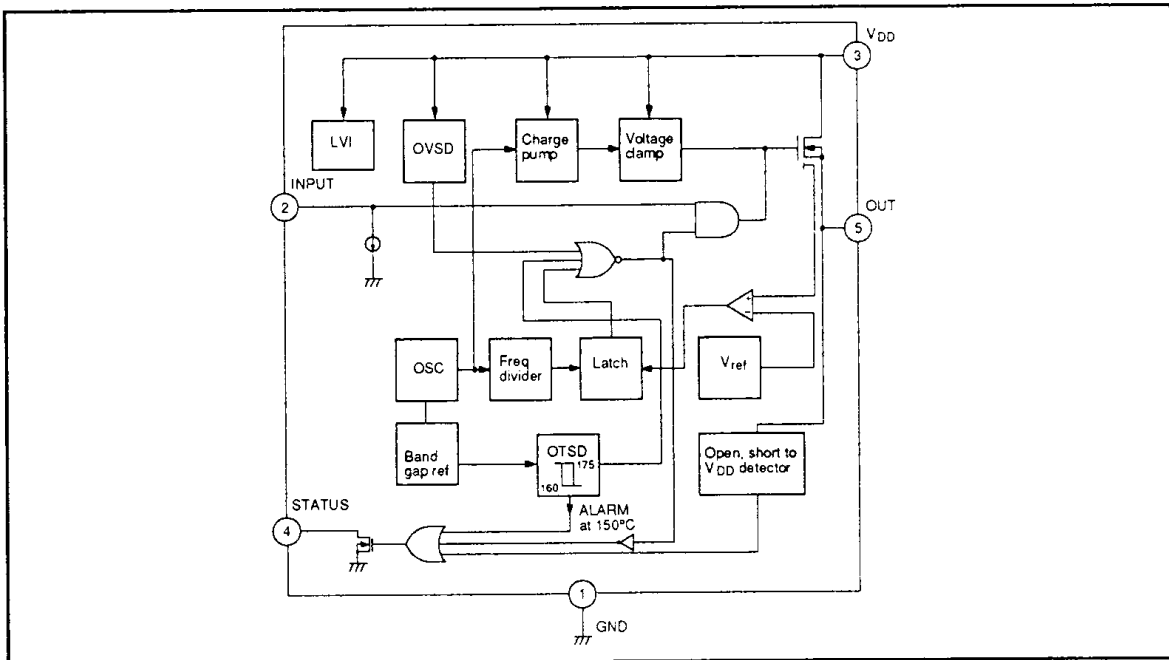
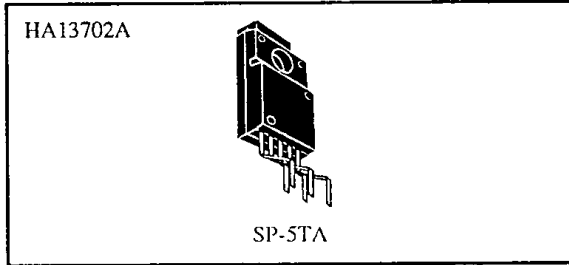
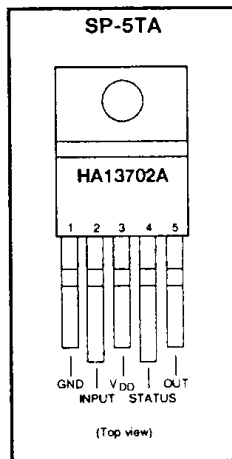

Figure 2 Block Diagram



### Pin Arrangement



### Ordering Information

Type No.	Package
HA13702A	SP-5TA

Figure 1 Pin Arrangement



# HA13702A

**Table 1 Truth Table**

Mode	In	Out	Status
Normal	L	L	H
	H	H	H
Load short	L	L	H
	H	L	L
Load open	L	L	H
	H	H	L
Short to V <sub>DD</sub>	L	H	L
	H	H	L
OTSD *1	L	L	L
	H	L	L
OVSD *2	L	L	L
	H	L	L
LVI *3	L	L	H
	H	L	H

Note: L: Low level (0.8 V)  
 H: High level (2.0 V)

- \*1) OTSD: Over temperature shut down
- \*2) OVSD: Over voltage shut down
- \*3) LVI: Low voltage inhibit

**Table 2 Absolute Maximum Ratings (Ta = 25°C)**

Item	Symbol	HA13702A	Unit	Note
Continuous supply voltage	V <sub>DD</sub>	-13 to +35	V	1
Transient supply voltage	V <sub>DD</sub>	60	V	2
Input voltage	V <sub>IN</sub>	-0.3 to +15	V	
Output voltage	V <sub>out</sub>	V <sub>DD</sub>	V	
Status voltage	V <sub>S</sub>	-0.3 to 15	V	
Output current	I <sub>out</sub>	—	A	3
Status current	I <sub>S</sub>	5	mA	
Power dissipation	P <sub>T</sub>	—	W	4
Package thermal resistance	Junction to case	θ <sub>jc</sub>	5	°C/W
	Junction to air	θ <sub>ja</sub>	70	°C/W
Junction temperature range	T <sub>j</sub>	-40 to OTSD	°C	5
Storage temperature range	T <sub>stg</sub>	-55 to 150	°C	

The absolute maximum ratings are limiting values, to be applied individually, beyond which the device may be permanently damaged. Functional operation under any of these conditions is not guaranteed. Exposing a circuit to its absolute maximum rating for extended periods of time may affect the device's reliability.

- Notes:
1. Recommended operating voltage:  
 V<sub>DD</sub> = 7 to 16 V (Normal)  
 16 to 25 V (Jump start)
  2. Load dump condition
  3. Internally limited
  4. Maximum power dissipation (P<sub>T</sub>(MAX)) can be defined as:  
 $P_T(\text{MAX}) = (T_{jopr}(\text{MAX}) - T_{\text{ambient}}) / (\theta_{jc} + \theta_{ca})$   
 θ<sub>ca</sub>: Thermal resistance between case and air (Depend on heat sink size)
  5. Operating junction temperature range  
 T<sub>jopr</sub> = -40 to +125°C

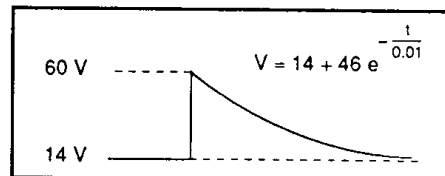

Table 3 Electrical Characteristics (Ta = 25°C)

Item	Symbol	Min	Typ	Max	Unit	Test condition	Pin	Note	
Output R <sub>(ON)</sub>	R <sub>DS(ON)</sub>	—	0.1	0.15	Ω	I <sub>o</sub> = 4 A (@T <sub>j</sub> = -40 to 25°C)	5		
		—	0.15	0.22	Ω	I <sub>o</sub> = 4 A (@T <sub>j</sub> = 125°C)	5		
Operating supply voltage range	V <sub>DD</sub>	7	—	25	V		3		
Quiescent current	I <sub>DD1</sub>	—	3	5	mA	V <sub>IN</sub> = 0 V, out = open	3		
	I <sub>DD2</sub>	—	6	10	mA	V <sub>IN</sub> = 5.5 V, out = open	3		
Output leak current	I <sub>LEAK</sub>	—	—	100	μA	V <sub>DD</sub> = 35 V, V <sub>IN</sub> = 0 V, T <sub>j</sub> = 125°C	5		
Input threshold voltage	V <sub>IL</sub>	—	—	0.8	V		2		
	V <sub>IH</sub>	2.0	—	—	V		2		
Input current	I <sub>IL</sub>	-10	—	60	μA	V <sub>IN</sub> = 0 to 0.8 V	2		
	I <sub>IH</sub>	5	35	60	μA	V <sub>IN</sub> = 2.0 to 5.5 V	2		
Propagation delay time	T <sub>d(ON)</sub>	—	20	—	μs	I <sub>o</sub> = 3 A	2, 5		
	T <sub>r</sub>	—	50	—	μs		5		
	T <sub>d(OFF)</sub>	—	20	—	μs		2, 5		
	T <sub>f</sub>	—	10	—	μs		5		
Open detect threshold current	I <sub>OD</sub>	0.3	0.7	1.2	A		4, 5		
Current limiter operating level	I <sub>CS</sub>	10	15	20	A		5	1	
Low Voltage Inhibit operating level	L.V.I	—	5	6	V				
Over voltage shut down	Operating level	OVSD	26	30	33	V		3	
	Hysteresys	V <sub>HYS</sub>	—	0.5	1.0	V		3	
Over temperature shut down	Operating level	OTSD	—	175	—	°C		5	2
		OTSD (Alarm)	—	150	—			4	2
	Hysteresys	T <sub>HYS</sub>	—	15	—	°C		5	2
Status on voltage	V <sub>SL</sub>	—	0.1	0.4	V	I <sub>S</sub> = 1 mA	4		
Status leak current	I <sub>S(Leak)</sub>	—	—	100	μA	V <sub>S</sub> = 5.5 V	4		

Notes: 1. Output current will be PWM controlled under current limit condition.  
2. Design parameter only (no test)

# HA13702A

## Bulb Drive Application and Its Waveform

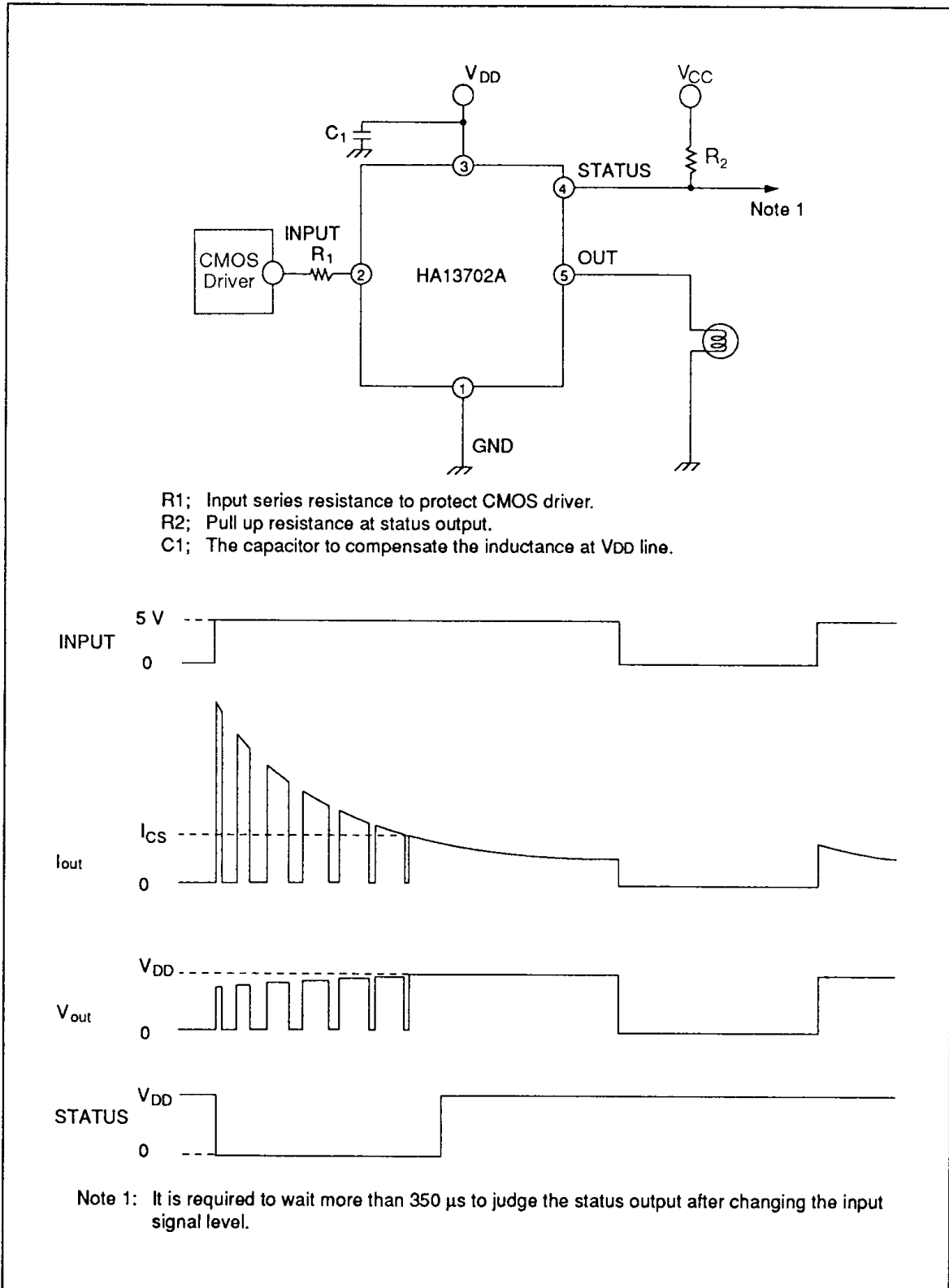

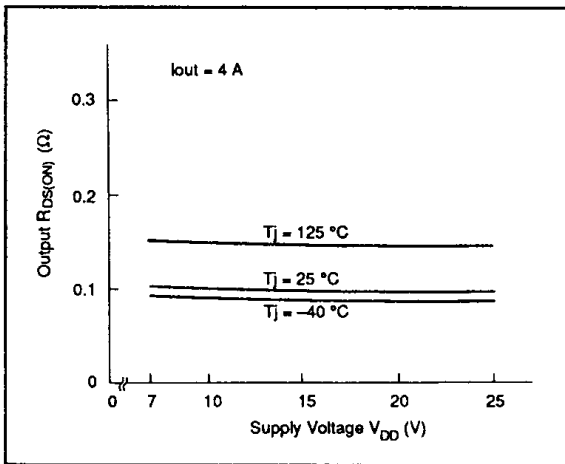

$R_{DS(ON)}$  vs.  $V_{DD}$

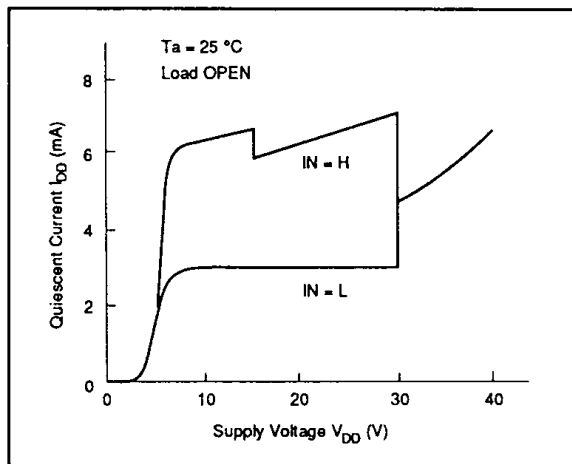

$I_{DD}$  vs.  $V_{DD}$

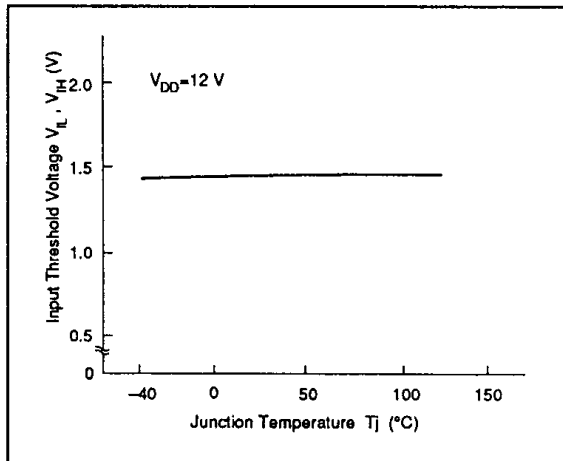

$V_{IL}$ ,  $V_{IH}$  vs.  $T_j$

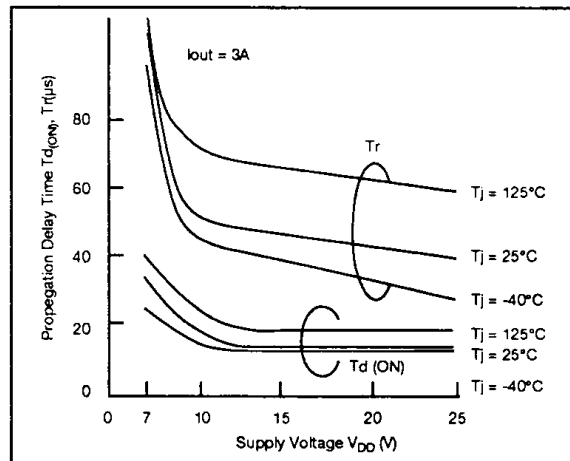

$T_{d(ON)}$ ,  $T_r$  vs.  $V_{DD}$

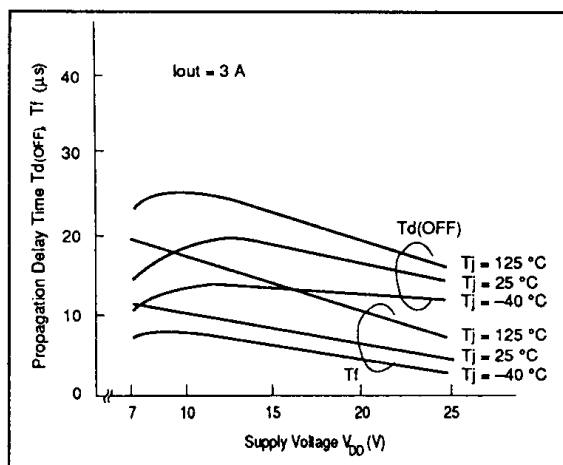

$T_{d(OFF)}$ ,  $T_f$  vs.  $V_{DD}$

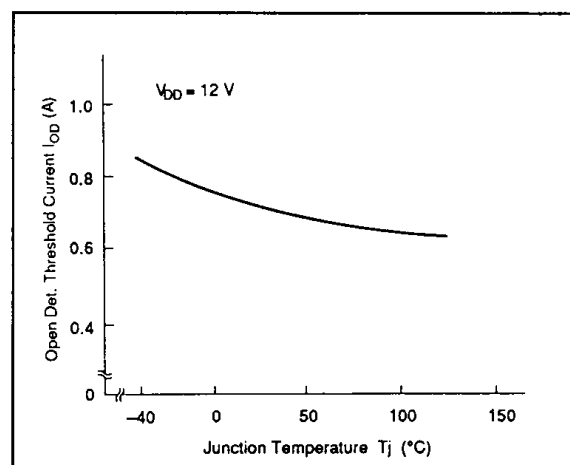

$I_{OD}$  vs.  $T_j$



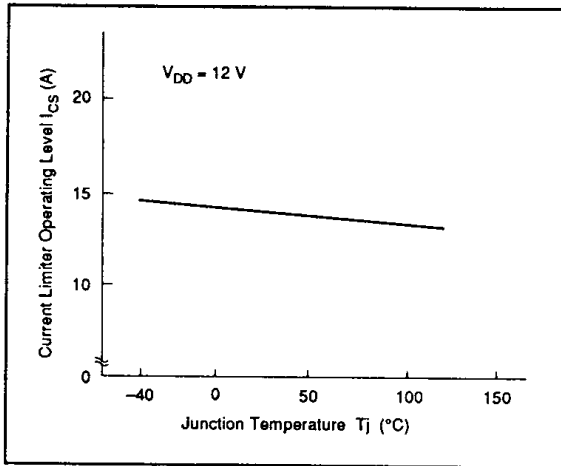

$I_{CS}$  vs.  $T_j$

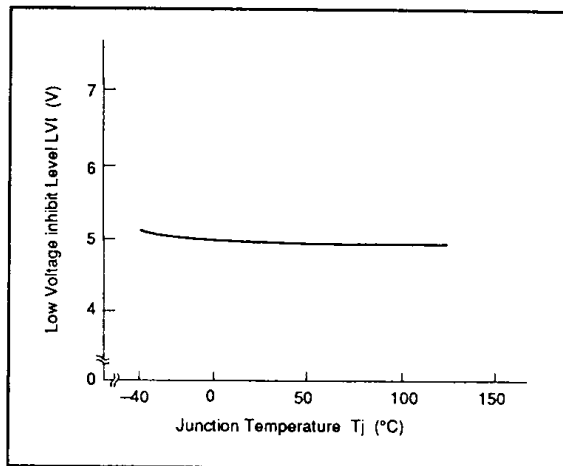

LVI vs.  $T_j$

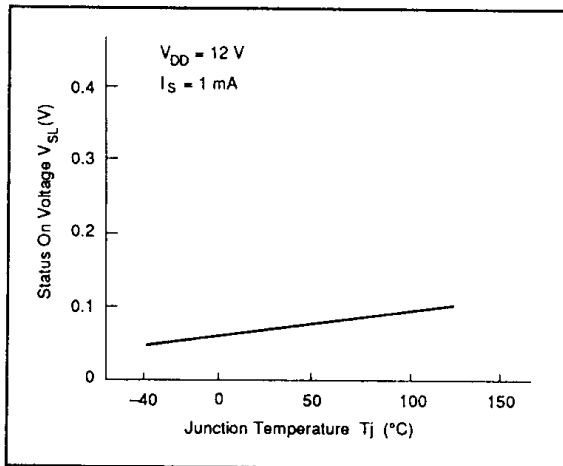

$V_{SL}$  vs.  $T_j$

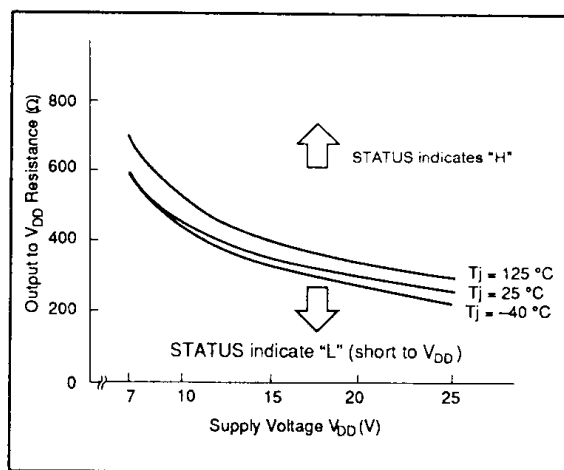

Short to  $V_{DD}$