

HA16103PJ

Voltage Regulator Control IC for Microcomputer Systems

The HA16103PJ monolithic voltage control is designed for microcomputer systems. In addition to voltage regulator, it includes watch dog timer function, power on reset function, and output voltage monitor function.

It is suitable for battery used microcomputer systems.

Functions

- 5 V Regulated power supply
- Power on reset pulse generator
- Watch dog timer
- Low voltage inhibit protection

Features

- Wide operational supply voltage range ($V_{CC} = 6$ to 40 V)
- Various control signals are generated when microcomputer system runaway occurs. (\overline{NMI} signal and \overline{STBY} signal are generated by detecting voltage level, and \overline{RES} signal is generated by monitoring the time after \overline{NMI} signal is detected)
- Regulated voltage, \overline{NMI} detecting voltage, \overline{STBY} detecting voltage are adjustable.
- At low voltage and re-start, the delay time of \overline{RES} signal is adjustable
- Watchdog timer filtering uses the minimum clock input pulse width and maximum cycle detection method

Ordering Information

Type No.	Package
HA16103PJ	DP-18

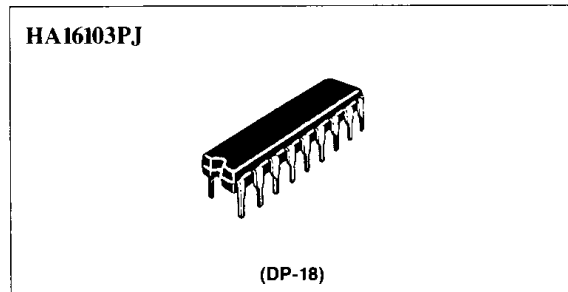

Pin Arrangement

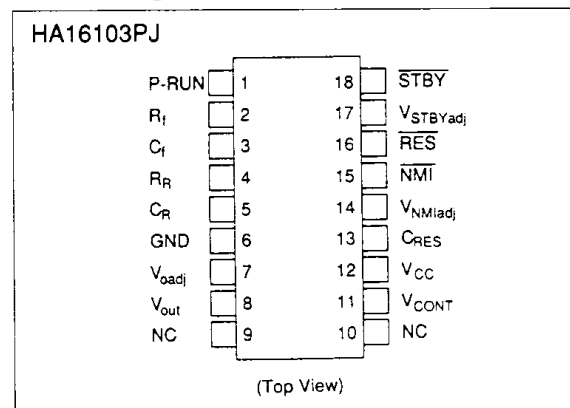

Block Diagram

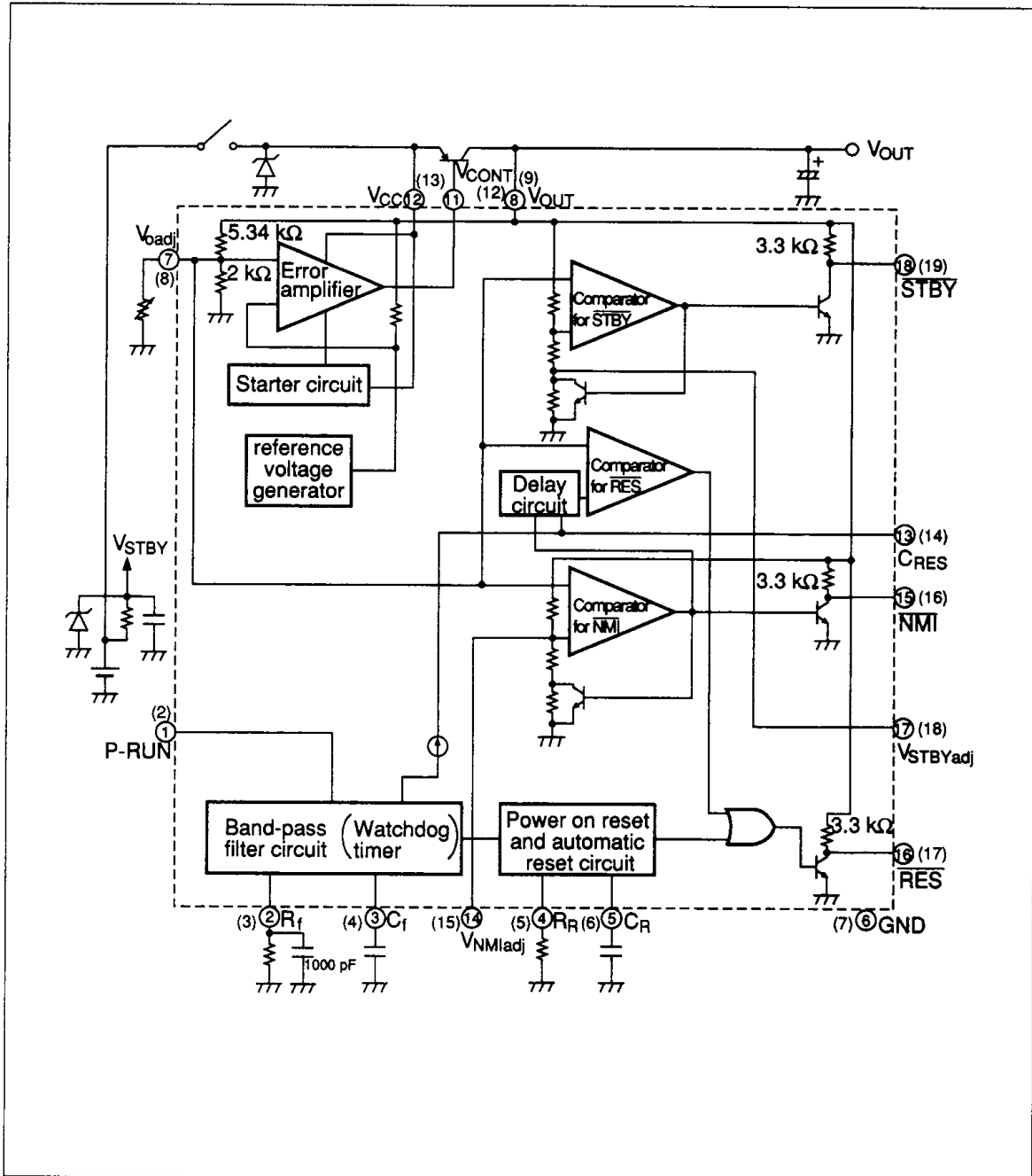

Table 1 Pin Functions

Pin Name No.	Description
1	P-RUN P-RUN signal input pin for watchdog timer
2	R_f Connect resistor R_f . Frequency bandwidth of the filter circuit depends on R_f
3	C_f Connect resistor C_f . Frequency bandwidth of the filter circuit depends on C_f
4	R_R Connect resistor R_R . Reset-signal power-on time depends on R_R
5	C_R Connect resistor C_R . Reset-signal power-on time depends on C_R
6	GND Ground
7	V_{oadj} 5-V reference voltage fine-tuning pin. Connect a resistor between this pin and GND. The value of output voltage is given by $V_{out} = \{1+5.34/(R1//2.0)\} \times V_{oadj}$ Unit for R1: $k\Omega$
8	V_{out} Connect the collector of an external PNP-type transistor. The pin supplies 5-V regulated voltage for internal circuit
9	NC NC pin
10	NC NC pin
11	V_{CONT} The external PNP-type transistor's base control pin
12	V_{CC} Supply voltage pin. Operating supply voltage range is 6.0 to 40 V
13	C_{RES} If the voltage of V_{out} pin declines to less than Detection voltage(1) (because of an instant power cut or other cause), \overline{NMI} signals are generated. If $t_{RES} \doteq 0.5 \cdot R_f \cdot C_{RES}(\text{sec})$ has passed since then, \overline{RES} signals are generated. If the voltage of V_{out} pin inclines to more than Detection voltage(1) (in case of re-start from LVI state), \overline{NMI} signals are stop. $t_r \doteq 0.5 \cdot R_f \cdot C_{RES}(\text{sec})$ has passed since then, \overline{RES} signals are stop. Connect capacitor C_{RES} between this pin and GND to adjust the \overline{RES} signals delay time(t_{RES} , t_r). If delay time is unnecessary, make this pin open ($t_{RES} = 2 \mu\text{s}$ typ. $t_r = 10 \mu\text{s}$ typ. at open)
14	V_{NMIadj} \overline{NMI} detection voltage fine-tuning pin. Connect a resistor between this pin and V_{out} pin or GND. The value of output voltage is given by $V_{NMI} = \{1+(R2//25.5)/(R3//10.6)\} \times V_{NMIadj}$. Unit for R2, R3: $k\Omega$
15	\overline{NMI} \overline{NMI} signal output pin. Connect to pin \overline{NMI} of the microcomputer
16	\overline{RES} \overline{RES} signal output pin. Connect to pin \overline{RES} of the microcomputer
17	$V_{STBYadj}$ STBY detection voltage tuning pin. Connect a resistor between this pin and V_{out} or GND. The value of output voltage is given by $V_{STBY} = 1.89 \times \{1+21/(7.9+8.85//R4)\} \times V_{STBYadj}$ Unit for R4: $k\Omega$
18	\overline{STBY} STBY signal output pin. Connect to pin \overline{STBY} of the microcomputer

Functional Description

Stabilized Power Supply Function

The stabilized power supply includes the following features:

- Wide range of operating input voltage from 6 V to 40 V to provide stabilized voltages
- Availability of any output current, by simply replacing the external transistor
- Fine adjustment of output voltage

Figure 1 shows the fine adjustment circuit of the output circuit. Select the resistor R₁ as shown in equation 1.

Add a resistor between GND and V_{oadj} to increase the output voltage.

$$R_1 = 1 / \{0.187(V_{out} / V_{oadj} - 1) - 0.5\} \quad \text{Equation 1}$$

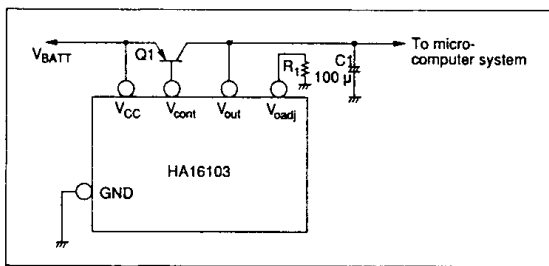

Figure 1 Fine Adjustment Circuit of Output Voltage

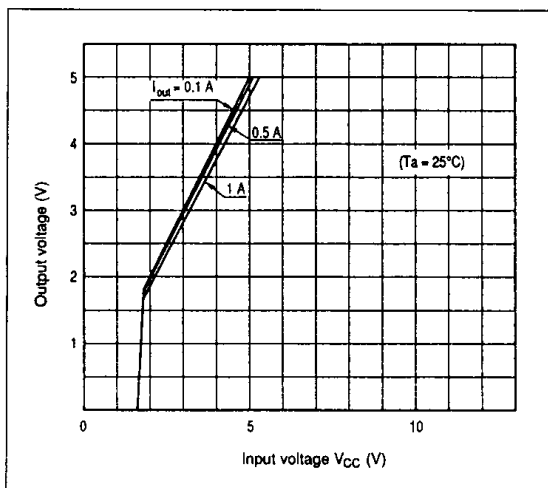

Figure 2 Output Voltage Characteristic

Power-On Reset Function

The system contains the power-on reset function required when a microcomputer is turned on. The reset period may be set with external components R_R and C_R. Equation 2 specifies how to determine the reset period (ton) and figure 3 shows the characteristic of the circuit.

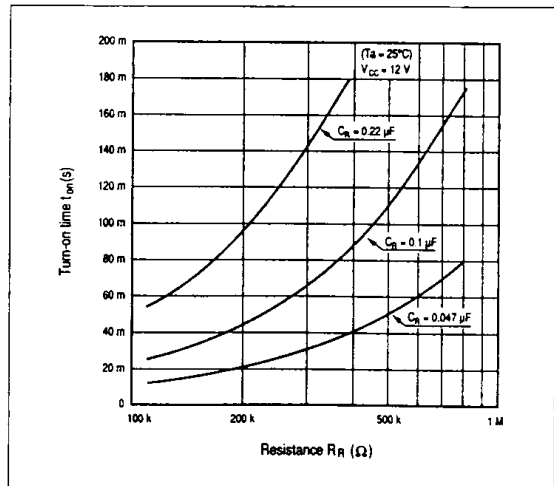
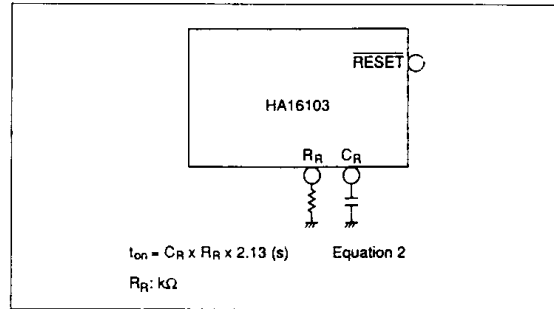
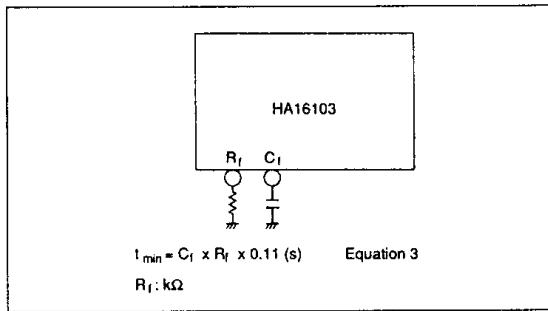

Figure 3 Characteristic of Power-On Reset Circuit

Watchdog Timer Function

The system contains a bandpass filter for pulse width detection, which outputs a reset pulse when input pulses are not at the preselected frequency (at either a higher or lower frequency).

The RC characteristic of the bandpass filter may be set with external components R_f and C_f. Equation 3 specifies how to determine the minimum pulse width (tmin) for runaway detection of the bandpass filter, (and figure 4 shows the characteristic of the filter.)



Low Voltage Monitoring Function

The system contains a circuit to send a control signal to the microcomputer when the output voltage drops. The circuit includes the following features.

- Two-point monitoring of output voltage (Vth1 and Vth2)
- Availability of fine adjustment of Vth1 (VNM1) and Vth2 (VSTBY)
- Output of control signal in standby mode of microcomputer

Figure 5 shows the timing chart of control signals when the output voltage drops.

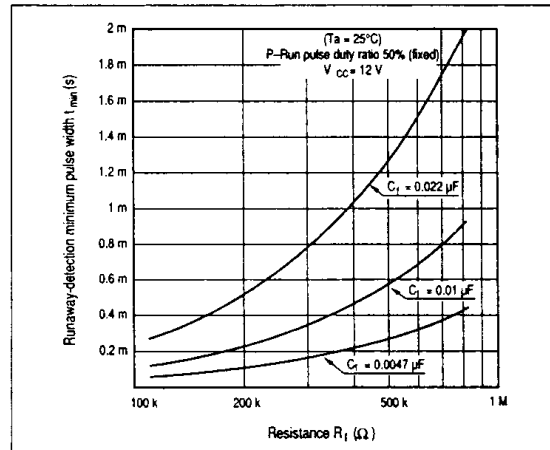

Figure 4 Characteristic of Power-On Reset Circuit

If the output voltage drops below Vth1 (4.60 V), the $\overline{\text{NMI}}$ signal rises to request the microcomputer to issue the $\overline{\text{NMI}}$ interrupt signal. The RESET signal falls t_{RES} seconds after the $\overline{\text{NMI}}$ signal rises. If the output voltage drops further to below Vth2 (3.2 V), the $\overline{\text{STBY}}$ signal rises to enable the microcomputer to enter standby mode.

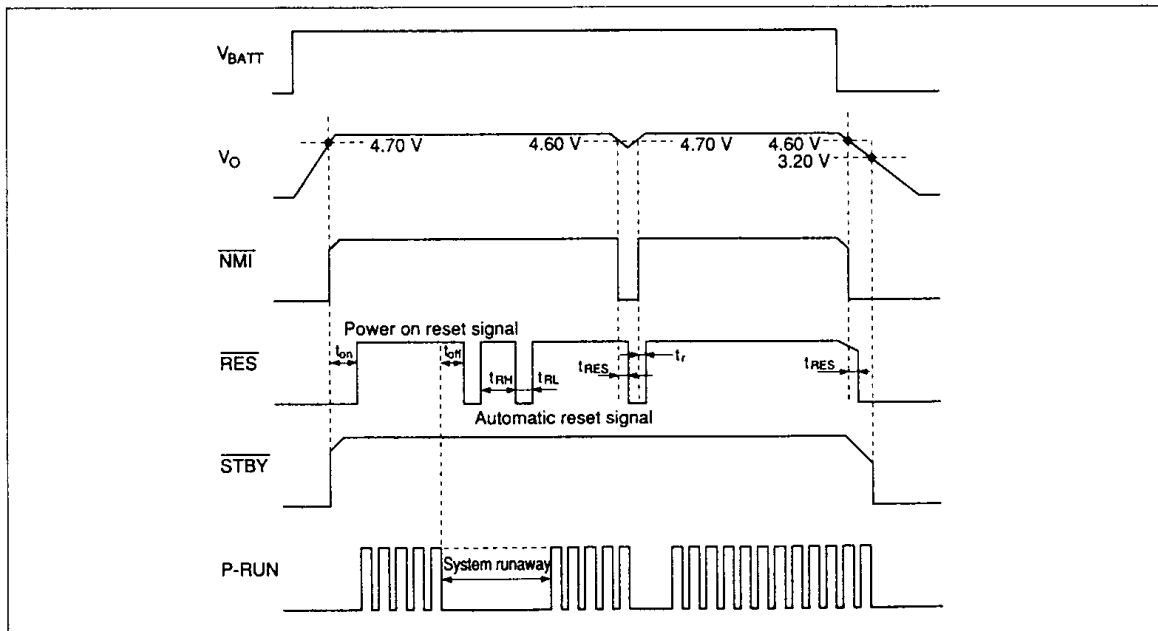

Figure 5 Timing Chart for Low Voltage Monitoring



HA16103PJ

Table 2 Absolute Maximum Ratings (Ta = 25°C)

Item	Symbol	Ratings	
		HA16103PJ	Units
V _{CC} supply voltage	V _{CC}	40	V
Control pin voltage	V _{CONT}	40	V
Control pin current	I _{CONT}	20	mA
V _{OUT} pin voltage	V _{OUT}	12	V
Power dissipation	P _T	400*	mW
Operating ambient temperature range	Topr	-40 to +85	°C
Storage temperature range	Tstg	-50 to +125	°C

The absolute maximum ratings are limiting values, to be applied individually, beyond which the device may be permanently damaged. Functional operation under any of these conditions is not guaranteed. Exposing a circuit to its absolute maximum rating for extended periods of time may affect the device's reliability.

- * Value under Ta ≤ 77°C. If Ta is greater, 8.3 mW/°C derating occurs.
- ** Allowable temperature of IC junction part, Tj (max.), is as shown below.
Tj (max.) = $\theta_j\text{-a} \cdot P_c \text{ (max.)} + T_a$
($\theta_j\text{-a}$ is thermal resistance value during mounting, and Pc (max.) is the maximum value of IC power dissipation.)
Therefore, to keep Tj (max.) ≤ 125°C, wiring density and board material must be selected according to the board thermal conductivity.
Be careful that the value of Pc (max.) does not exceed that P_T.



Table 3 Electrical Characteristics (Ta = 25°C, V_{DD} = 12 V, V_{out} = 5 V)

Items	Symbols	Min	Typ	Max	Units	Test Conditions	
Supply current	I _{CCL}	—	8	12	mA	V _{CC} = 12 V	
Regulator	Output voltage	V _{O1}	4.80	5.00	5.20	V	V _{CC} = 6 to 17.5 V I _{OUT} = 0.5 A, R ₁ = 30 kΩ
		V _{O2}	4.70	5.00	5.30	V	V _{CC} = 6 to 17.5 V I _{OUT} = 1 A, R ₁ = 30 kΩ
Line regulation	V _{oline}	-50	—	50	mV	V _{CC} = 6 to 17.5 V I _{out} = 1 A, R ₁ = 30 kΩ	
Load regulation	V _{oload}	-100	—	100	mV	I _{out} = 10 mA to 1.5 A, R ₁ = 30 kΩ	
Ripple rejection	R _{REJ}	45	75	—	dB	V _i = 0.5 V _{rms} , f _i = 1 kHz, R ₁ = 30 kΩ	
Output voltage Temperature coefficient	δV _o /δT	—	0.6	—	mV/°C	V _{CC} = 12 V, R ₁ = 30 kΩ	
Clock input	"L"-input voltage	V _{IL}	—	—	0.8	V	
	"H"-input voltage	V _{IH}	2.0	—	—	V	
	"L"-input current	I _{IL}	-120	-60	—	μA	V _{IL} = 0 V
	"H"-input current	I _{IH}	—	0.3	0.5	mA	V _{IH} = 5 V
NMI output	NMI pin "L"-level voltage	V _{OL1}	—	—	0.4	V	I _{OL1} = 2 mA
	NMI pin "H"-level voltage	V _{OH1}	—	V _{O1} (V _{O2})	—	V	
	NMI function start V _{out} voltage	V _{NMI}	—	0.7	1.4	V	
STBY output	STBY pin "L"-level voltage	V _{OL2}	—	—	0.4	V	I _{OL2} = 2 mA
	STBY pin "H"-level voltage	V _{OH2}	—	V _{O1} (V _{O2})	—	V	
	STBY function start V _{out} voltage	V _{STBY}	—	0.7	1.4	V	

HA16103PJ

Table 3 Electrical Characteristics ($T_a = 25^\circ\text{C}$, $V_{DD} = 12\text{ V}$, $V_{out} = 5\text{ V}$) (Cont)

Items	Symbols	Min	Typ	Max	Units	Test Conditions	
RES output	RES pin "L"-level voltage	V_{OL3}	—	—	0.4	V $I_{OL3} = 2\text{ mA}$	
	RES pin "H"-level voltage	V_{OH3}	—	V_{O1} (V_{O2})	—	V	
	RES function start Vout voltage	V_{RES}	—	0.7	1.4	V	
	Power on time	t_{ON}	25	40	60	ms	$R_f = 180\text{ k}\Omega$, $R_R = 180\text{ k}\Omega$ $C_f = 0.01\text{ }\mu\text{F}$, $C_R = 0.1\text{ }\mu\text{F}$
	Clock off reset time	t_{OFF}	80	130	190	ms	
	Reset pulse "L"-level time	t_{RL}	15	20	30	ms	$R_f = 180\text{ k}\Omega$, $R_R = 180\text{ k}\Omega$ $C_f = 0.01\text{ }\mu\text{F}$, $C_R = 0.1\text{ }\mu\text{F}$
	Reset pulse "H"-level time	t_{RH}	37	60	90	ms	$R_f = 180\text{ k}\Omega$, $R_R = 180\text{ k}\Omega$ $C_f = 0.01\text{ }\mu\text{F}$, $C_R = 0.1\text{ }\mu\text{F}$
Low Voltage Protection	Detection voltage(1)	V_{H1}	4.40	4.60	4.80	V	
	Detection voltage(1) Hysteresis width	V_{HYS1}	50	100	150	mV	
	Detection voltage(2)	V_{H2}	2.9	3.2	3.5	V	
	Detection voltage(2) Hysteresis width	V_{HYS2}	1.35	1.5	1.65	V	
	Reset pulse Delay time	inhibit	t_{RES}	—	200	—	μs $C_{RES} = 2200\text{ pF}$
		restart	t_r	—	200	—	μs $C_{RES} = 2200\text{ pF}$

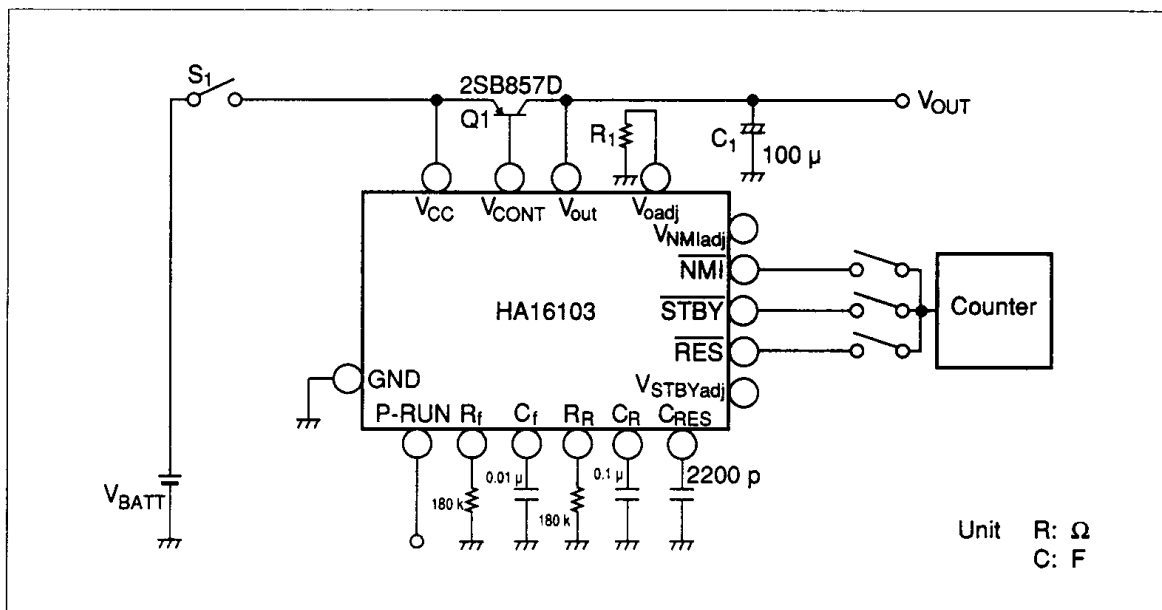

Figure 7 Test Circuit



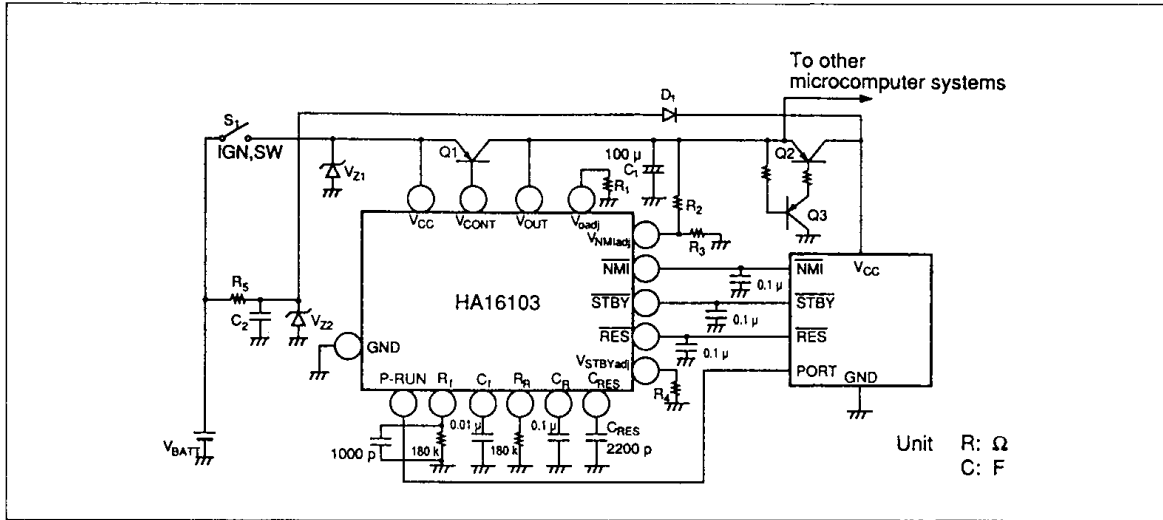

Figure 8 Sample Connection Circuit

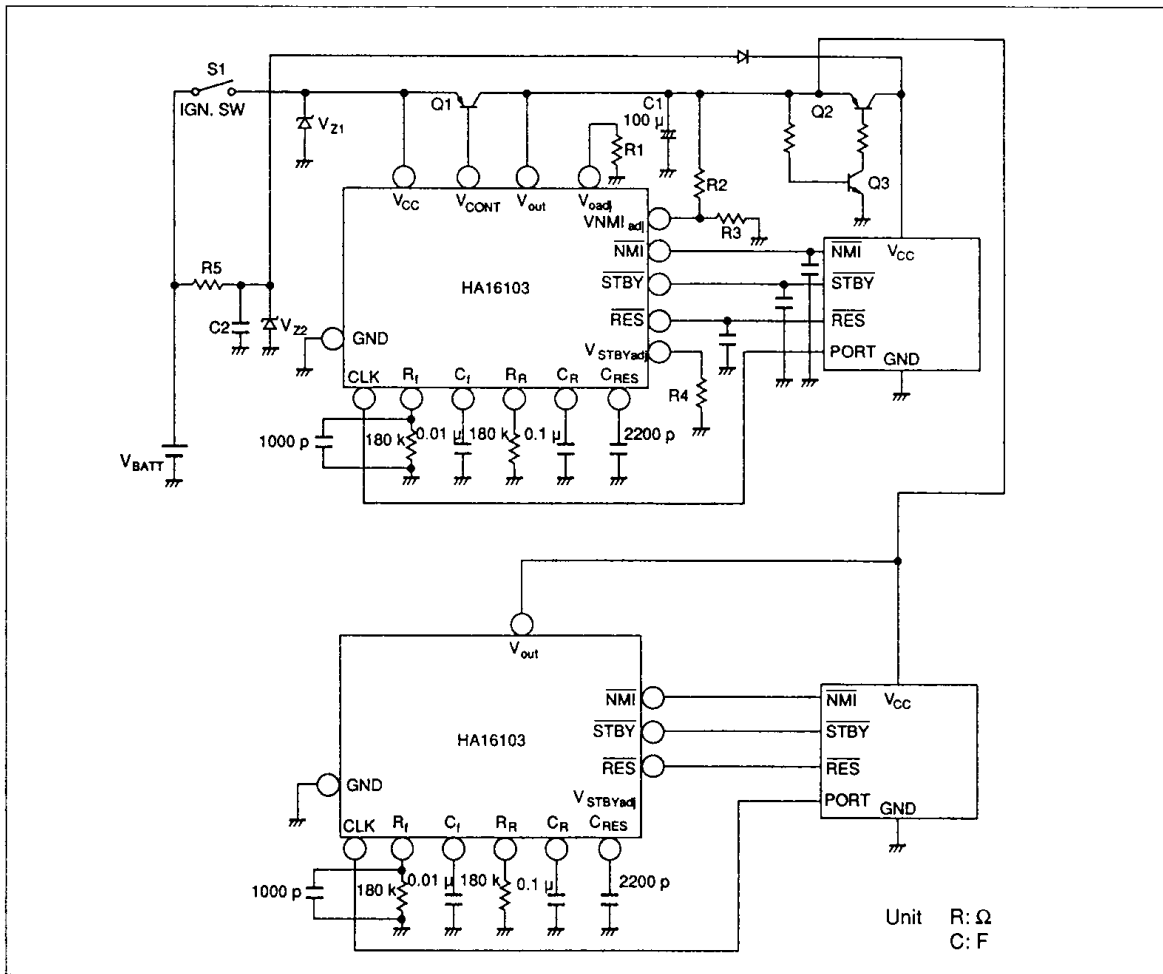

Figure 9 Sample Connection Circuit

