

GaAs MMIC SMT 5 - BIT DIGITAL ATTENUATOR DC - 2.0 GHz

FEBRUARY 2001

v01.0301

Features

BANDWIDTH: DC-2 GHz

BIT LEVELS: 1, 2, 4, 8, 16 dB

FAST SWITCHING: 6 ns

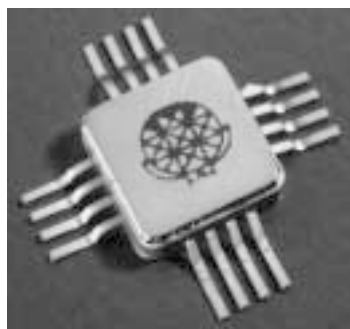

General Description

The HMC110G16 is a 5-bit surface mount hermetically sealed digital attenuator. Each bit is activated by applying a 0V control, and then disabled by applying -5V control to the specified control pin. The five primary attenuation states can be activated independently, or collectively for a maximum combined attenuation level of 31 dB. See the non-hermetic wide band DC - 6 GHz HMC110C14.

2
ATTENUATORS
SMT

Guaranteed Performance With 0/-5V Control, -40 to +85 deg C

Parameter	Freq.	Min.	Typ.	Max.	Units
Insertion Loss	DC-2 GHz		5	5.4	dB
Attenuation Range	DC-2 GHz	27	31		dB
Return Loss	DC-2 GHz	10	17		dB
Attenuation Accuracy:					
1 - 7 dB States	DC-2 GHz	+ / - 0.5 dB +/- 8% of Setting Max.			dB
8 - 15 dB States	DC-2 GHz	+ / - 0.6 dB +/- 8% of Setting Max.			dB
16 - 23 dB States	DC-2 GHz	+ / - 0.8 dB +/- 10% of Setting Max.			dB
24 - 31 dB States	DC-2 GHz	+ / - 0.8 dB +/- 12% of Setting Max.			dB
Switching Characteristics					
tRISE, tFALL (10/90%)	DC-2 GHz		3		ns
tON, tOFF (50% CTL to 10/90% RF)			6		ns
Input Power for 0.2 dB Comp					
Min Atten:	0.5 - 2		+22		dBm
Max Atten:			+ 5		dBm
Input Third Order Intercept Point					
Min Atten:	0.5 - 2		+44		dBm
Max Atten:			+32		dBm

HMC110G16 SMT 5 - BIT DIGITAL ATTENUATOR DC - 2.0 GHz

v01.0301

FEBRUARY 2001

Insertion Loss

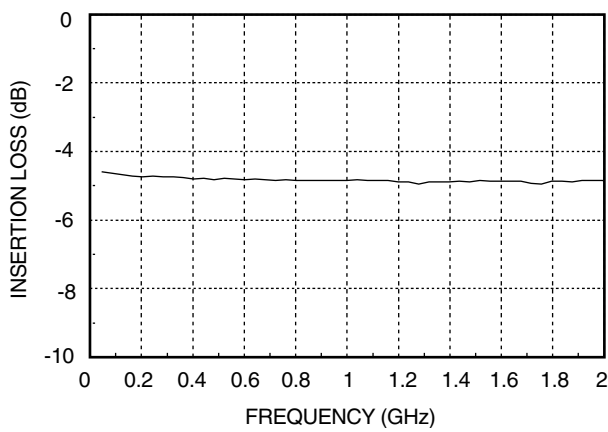

Relative Attenuation

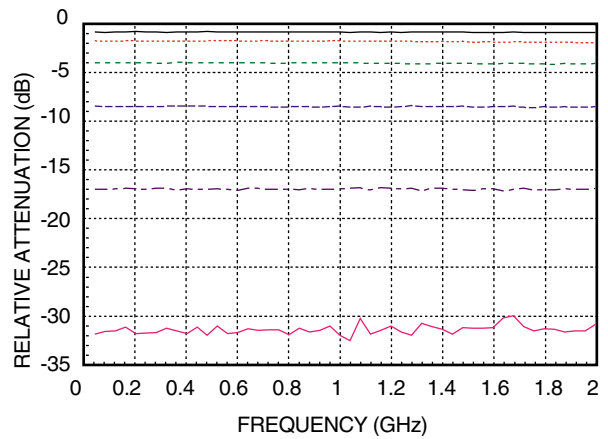

Relative Phase

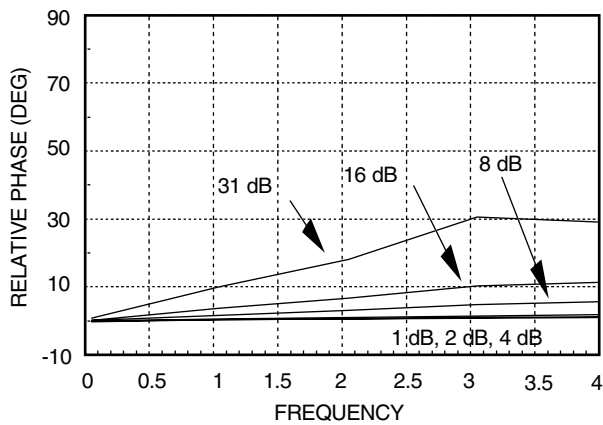

Return Loss

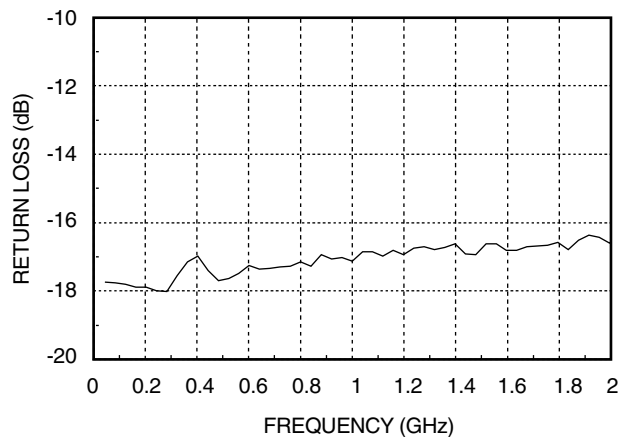

2
ATTENUATORS
SMT



HMC110G16 SMT 5 - BIT DIGITAL ATTENUATOR DC - 2.0 GHz

FEBRUARY 2001

v01.0301

Schematic

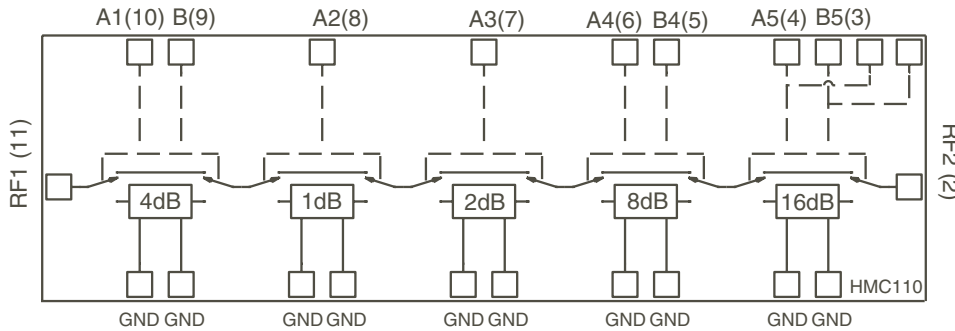

Pins 1, 12 - 16 and package bottom are GND.

2
ATTENUATORS
SMT

Absolute Maximum Ratings

Control Voltage Range	+0.5 to -8.5 Vdc
Storage Temperature	-65 to +150 deg C
Operating Temperature	-40 to +125 deg C
RF Input Power (0.5 - 4 GHz)	+27 dBm
Insertion Loss State	+13 dBm
Any Attenuation State	

Truth Table

Control Input								Att Set
4 dB Bit		1dB	2dB	8dB Bit		16dB Bit		
A1	B1	A2	A3	A4	B4	A5	B5	
Hi	Lo	Hi	Hi	Hi	Lo	Hi	Lo	Ref
Hi	Lo	Lo	Hi	Hi	Lo	Hi	Lo	1dB
Hi	Lo	Hi	Lo	Hi	Lo	Hi	Lo	2dB
Lo	Hi	Hi	Hi	Hi	Lo	Hi	Lo	4dB
Hi	Lo	Hi	Hi	Lo	Hi	Hi	Lo	8dB
Hi	Lo	Hi	Hi	Hi	Lo	Lo	Hi	16dB

Any combination of above states will provide an attenuation approximately equal to the sum of the bits selected.

Control Voltages

State	Bias Condition
Low	0 to -0.2V @ 20uA Max
High	-3V @ 50uA Typ to -8V @ 500uA Max

HMC110G16 SMT 5 - BIT DIGITAL ATTENUATOR DC - 2.0 GHz

v01.0301

FEBRUARY 2001

Outline

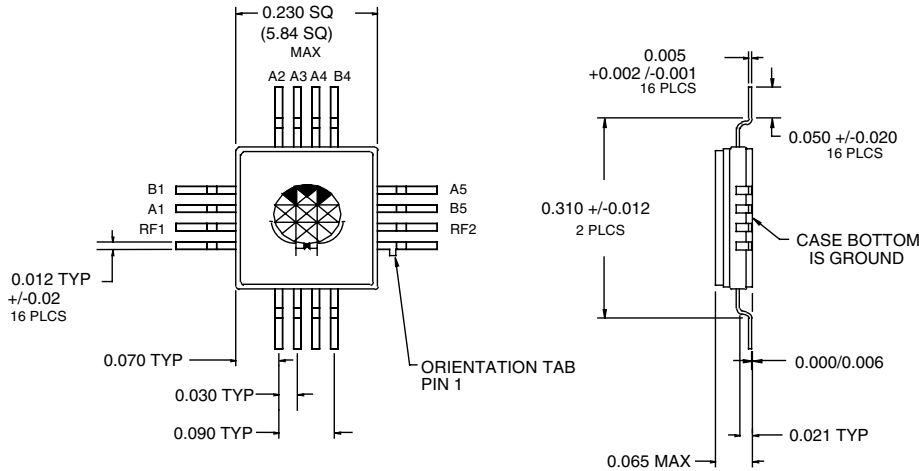

1. MATERIAL:
 A) PACKAGE BODY - ALUMINA LOADED BOROSILICATE GLASS (#7052 CORNING.)
 B) LEADS, BASE, & COVER - KOVAR (TM)
2. PLATING: ELECTROLYTIC GOLD 50 MICROINCHES MINIMUM, OVER ELECTROLYTIC NICKEL 75 MICROINCHES MINIMUM.
3. ALL UNLABELED LEADS ARE GROUND AND PACKAGE BOTTOM IS RF GROUND

2
ATTENUATORS
SMT

Suggested Driver Circuit

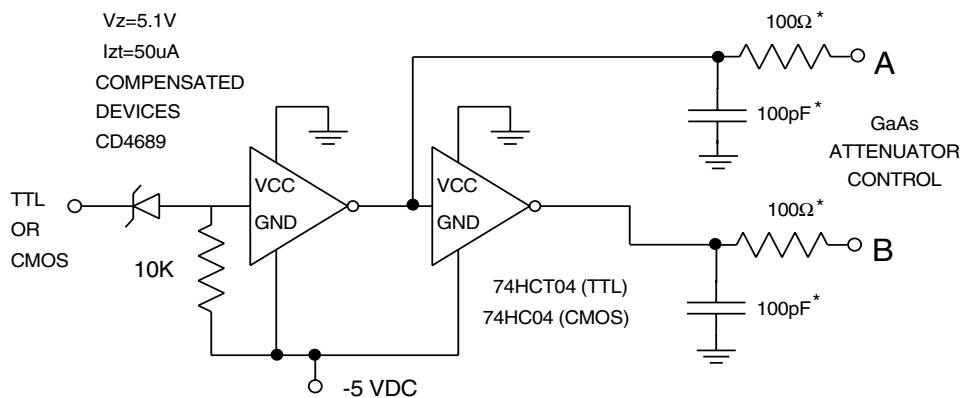

Simple driver using inexpensive standard logic ICs provides fast switching using minimum DC current.
 * Recommended values to suppress unwanted RF signals at A/B control lines. You may adjust for switching speed considerations.