

## GaAS MMIC SP4T SWITCH DC TO 2.0 GHz

FEBRUARY 2001

v01.0101

### Features

LOW INSERTION LOSS: 0.4dB

INTEGRATED 2:4 DECODER

14 LEAD SOIC PACKAGE



### General Description

The HMC165S14 is a low-cost SP4T switch in a 14-lead SOIC package for use in antenna diversity, switched filter banks, gain/attenuation selection, and general channel multiplexing applications. The switch can control signals up to 2.5 GHz and is especially suited for 800-1000 MHz basestation applications\*. A 2:4 decoder is integrated on the switch, requiring only 2 control lines and a negative bias to select each RF path. Switch outputs are reflective shorts when "Off". The 2:4 decoder replaces 4 to 8 control lines normally required by GaAs SP4T switches. See positive bias/TTL SP4T HMC241QS16.

### Guaranteed Performance

For 0/-5V Control and Vee = -5V in a 50 Ohm System, -40 to +85 deg C

Parameter	Frequency	Min.	Typ.	Max.	Units
Insertion Loss	DC - 0.5GHz		0.3	0.6	dB
	DC - 1.0GHz		0.5	0.8	dB
	DC - 2.0GHz		1.0	1.3	dB
Isolation	DC -0.5GHz	35	39		dB
	DC - 1.0GHz	28	32		dB
	DC - 2.0GHz	20	24		dB
Return Loss	DC -1.0GHz	16	20		dB
	DC - 2.0GHz	8.5	11		dB
Input Power for 1dB Compression	50 MHz		22		dBm
	0.5 - 2.0GHz		24		
Input Third Order Intercept	50 MHz		35		dBm
	0.5 - 2.0GHz		42		
Switching Characteristics tRISE, tFALL (10/90% RF) tON, tOFF (50% CTL to 10/90% RF)	DC - 2.0GHz		25		ns
			50		ns

## HMC165S14 SP4T SWITCH DC TO 2.0 GHz

v01.0101

FEBRUARY 2001

### Insertion Loss

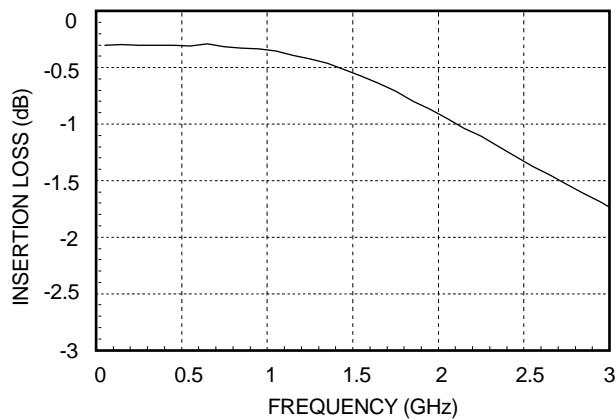

### Isolation

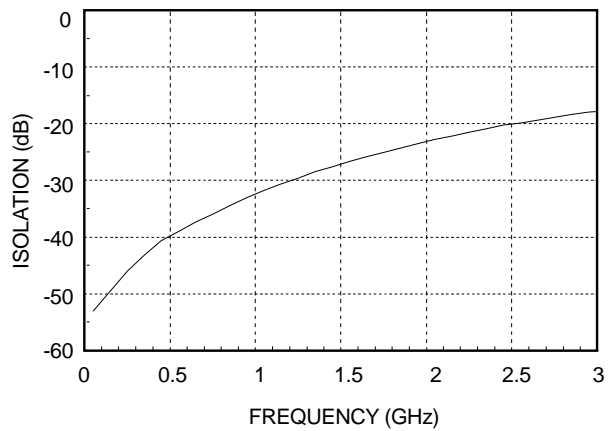

### Return Loss

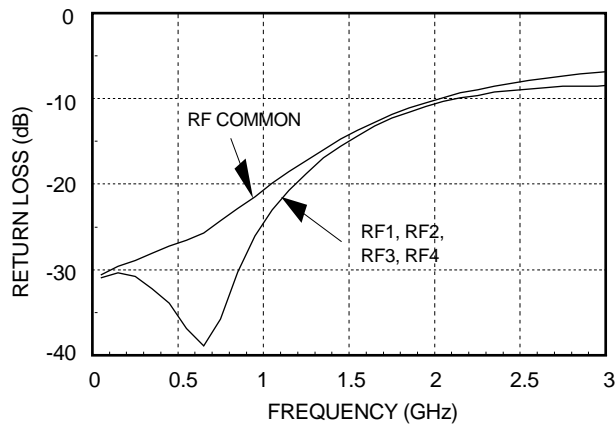

## HMC165S14 SP4T SWITCH DC TO 2.0 GHz

FEBRUARY 2001

v01.0101

### Functional Diagram

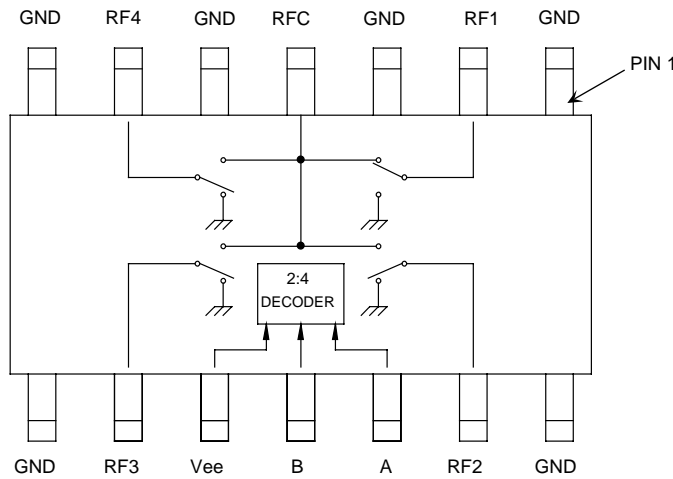

### Absolute Maximum Ratings

Bias Voltage Range (Port Vee)	-7.0 Vdc
Control Voltage Range (A & B)	Vee -0.5V to +1.0 Vdc
Storage Temperature	-65 to +150 deg C
Operating Temperature	-40 to +85 deg C
Maximum Input Power	+27dBm (<500MHz) +30dBm (>500MHz)

### Truth Table

Control Input		Signal Path State
A	B	RFCOM to:
High	High	RF1
Low	High	RF2
High	Low	RF3
Low	Low	RF4

### Bias Voltage & Current

Vee Range = -5.0 Vdc ± 10%		
Vee (Vdc)	Iee (Typ.) (mA)	Iee (Max.) (mA)
-5.0	3.0	6.0

### Control Voltages

State	Bias Condition
Low	0 to -3 VDC @ 220uA Typ.
High	Vee +0.8 VDC @ 100uA Max.

7

SWITCHES

SP4T

SMT



## HMC165S14 SP4T SWITCH DC TO 2.0 GHz

v01.0101

FEBRUARY 2001

### Outline

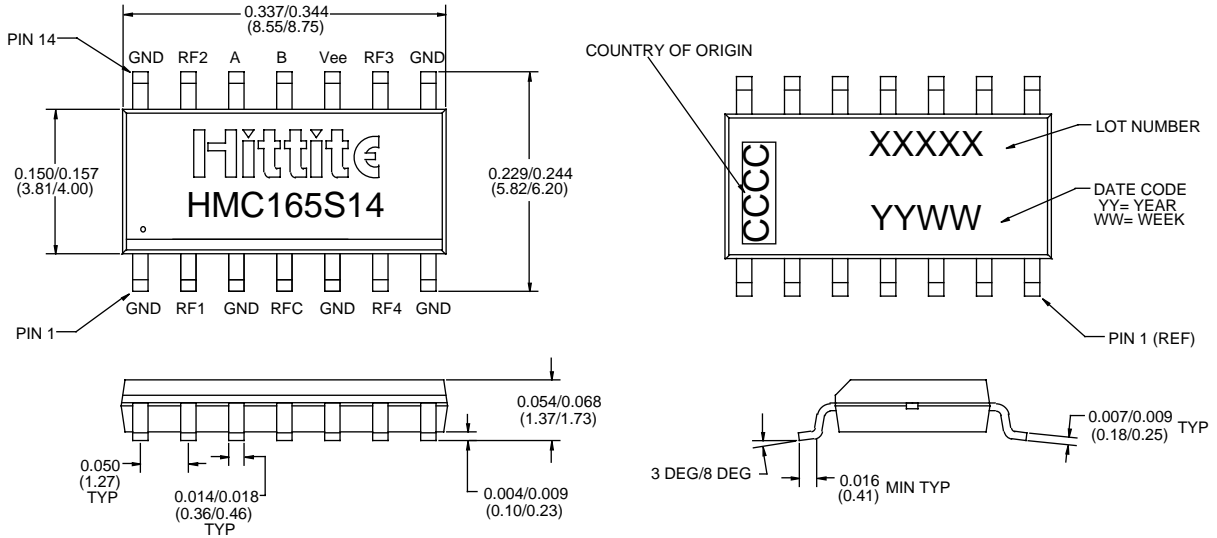

- 1) MATERIAL:
  - A) PACKAGE BODY LOW STRESS INJECTION MOLDED PLASTIC, SILICA & SILICONE IMPREGNATED
  - B) LEADFRAME MATERIAL: COPPER ALLOY
2. PLATING: LEAD-TIN SOLDER PLATE
3. DIMENSIONS ARE IN INCHES (MILLIMETERS) UNLESS OTHERWISE SPECIFIED TOL. ARE  $\pm 0.005 (\pm 0.13)$

### TTL Interface Circuit

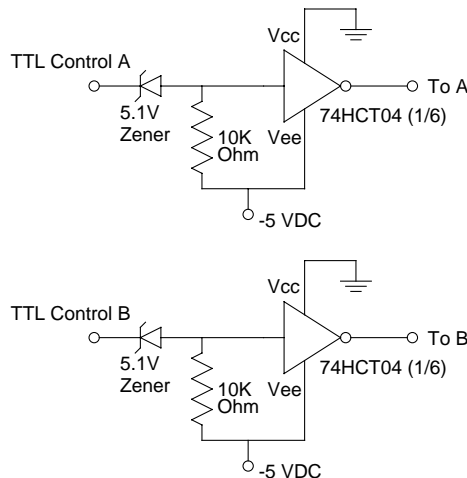

**Note:**

Control inputs A and B can be driven directly with TTL logic with -5 Volts applied to the HCT logic gates (Vee) and to Vee (pin 10) of the RF switch.