

Features

- Operating voltage: 2.4V~12V
- Low power and high noise immunity CMOS technology
- Low standby current
- Minimum transmission word
 - Four words for \overline{TE} trigger
 - One word for Data trigger
- Built-in oscillator needs only 5% resistor
- Easy interface with an RF or an infrared transmission medium
- Minimal external components
- Package information: refer to Selection Table

Applications

- Burglar alarm system
- Smoke and fire alarm system
- Garage door controllers
- Car alarm system
- Security system
- Cordless telephones
- Other remote control systems

General Description

The 3¹² encoders are a series of CMOS LSIs for remote control system applications. They are capable of encoding 12 bits of information which consists of N address bits and 12-N data bits. Each address/data input is externally trinary programmable if bonded out. They are otherwise set floating internally. Various packages of the 3¹² encoders offer flexible combinations of

programmable address/data which meet various applications. The programmable address/data is transmitted together with the header bits via an RF or an infrared transmission medium upon receipt of a trigger signal. A \overline{TE} (HT6010) or a DATA (HT6012/HT6014) trigger can be selected for application flexibility.

Selection Table

Function Part No.	Address No.	Address/ Data No.	Data No.	Oscillator	Trigger	LED Indicator	Package
HT6010	8	4	0	RC oscillator	\overline{TE}	No	18/20 DIP 20 SOP
HT6012	10	0	2	RC oscillator	D10~D11	Yes	18 DIP/20 SOP
HT6014	8	0	4	RC oscillator	D8~D11	Yes	18 DIP/20 SOP

Note: Address/Data represents addressable pins or data according to the requirements of decoders.

Block Diagram

\overline{TE} trigger

HT6010

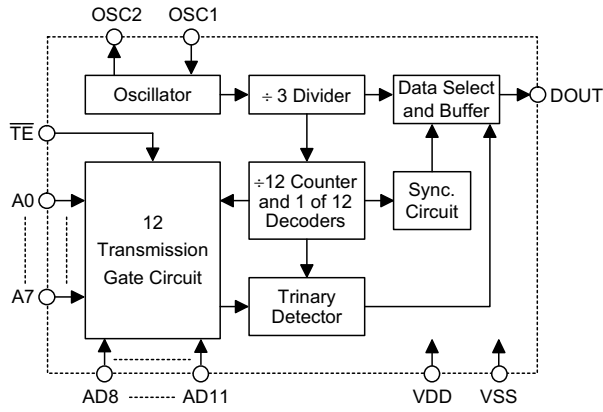

DATA trigger

HT6012/HT6014

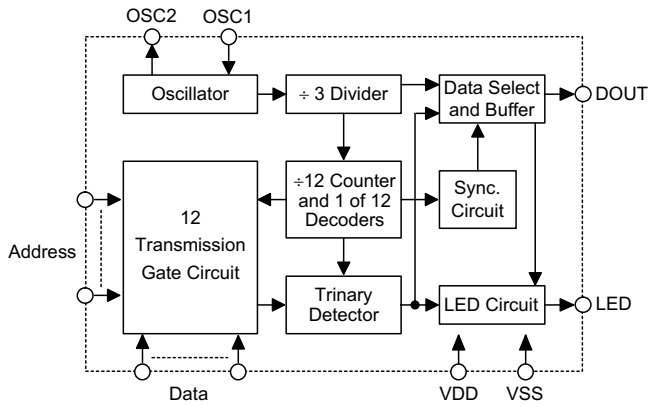

Note: The address/data pins are available in various combinations (refer to the address/data table).

Pin Assignment

\overline{TE} trigger type

**8-Address
4-Address/Data**

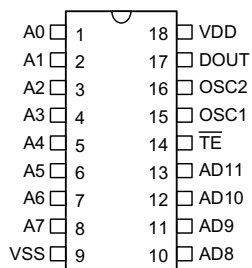

**HT6010
-18 DIP**

**8-Address
4-Address/Data**

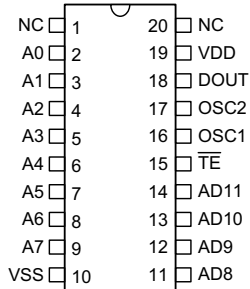

**HT6010
-20 DIP/SOP**

DATA trigger type

**10-Address
2-Data**

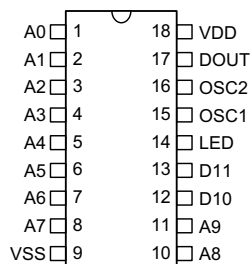

**HT6012
-18 DIP**

**10-Address
2-Data**

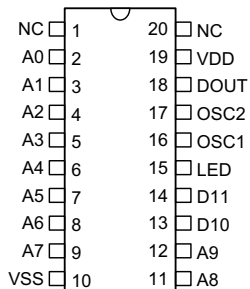

**HT6012
-20 SOP**

**8-Address
4-Data**

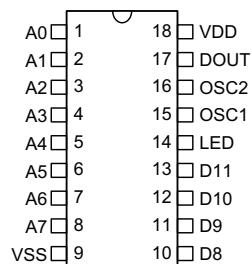

**HT6014
-18 DIP**

**8-Address
4-Data**

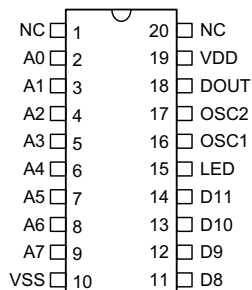

**HT6014
-20 SOP**

Pin Description

Pin Name	I/O	Internal Connection	Description
A0~A9	I	TRANSMISSION GATE	Input pins for address A0~A9 setting They can be externally set to VDD or VSS or left open.
AD8~AD11	I	TRANSMISSION GATE	Input pins for address/data (AD8~AD11) setting They can be externally set to VDD or VSS or left open.
D8~D11	I	CMOS IN Pull-high	Input pins for data (D8~D11) setting and transmission enable (active low) They can be externally set to VSS or left open (see Note).
DOUT	O	CMOS OUT	Encoder data serial transmission output
LED	O	NMOS OUT	Transmission enable indicator, active low
\overline{TE}	I	CMOS IN Pull-high	Transmission enable, active low (see Note)
OSC1	I	OSCILLATOR	Oscillator input pin
OSC2	O	OSCILLATOR	Oscillator output pin
VSS	—	—	Negative power supply, ground
VDD	—	—	Positive power supply

Note: D8~D11 are data input and transmission enable pins of the HT6012/HT6014.

\overline{TE} is the transmission enable pin of the HT6010.

Approximate internal connections

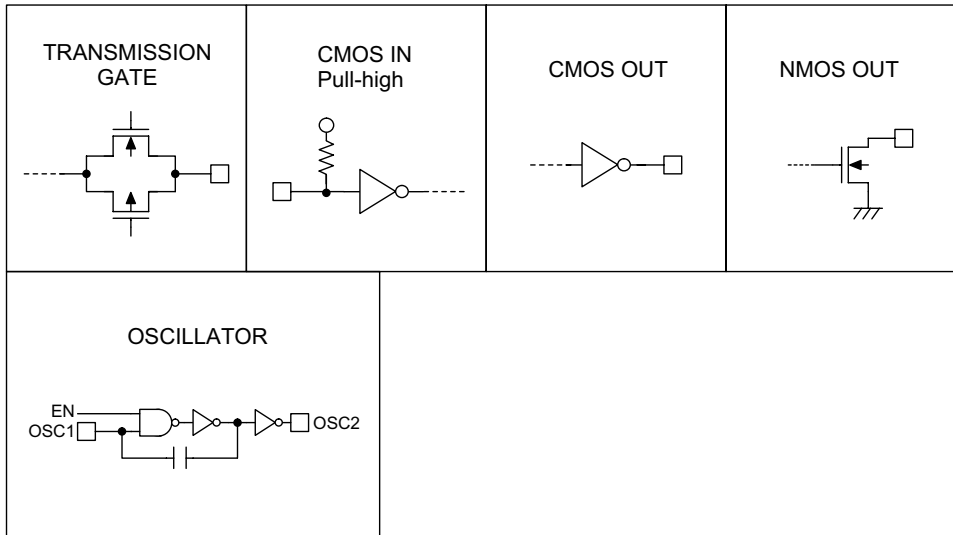

Absolute Maximum Ratings

Supply Voltage.....-0.3V to 13V Storage Temperature.....-50°C to 125°C
 Input Voltage..... $V_{SS}-0.3$ to $V_{DD}+0.3V$ Operating Temperature-20°C to 75°C

Note: These are stress ratings only. Stresses exceeding the range specified under "Absolute Maximum Ratings" may cause substantial damage to the device. Functional operation of this device at other conditions beyond those listed in the specification is not implied and prolonged exposure to extreme conditions may affect device reliability.

Electrical Characteristics
 $T_a=25^\circ\text{C}$

Symbol	Parameter	Test Conditions		Min.	Typ.	Max.	Unit
		V_{DD}	Conditions				
V_{DD}	Operating Voltage	—	—	2.4	5	12	V
I_{STB}	Standby Current	3V	Oscillator stops	—	0.1	1	μA
		12V		—	2	4	μA
I_{DD}	Operating Current	3V	No load $f_{OSC}=3\text{kHz}$	—	250	500	μA
		12V		—	600	1200	μA
I_{LED}	LED Sink Current	5V	$V_{LED}=0.5V$	1.5	3	—	mA
I_{DOUT}	Output Drive Current	5V	$V_{OH}=0.9V_{DD}$ (Source)	-0.6	-1.2	—	mA
		5V	$V_{OL}=0.1V_{DD}$ (Sink)	0.6	1.2	—	mA
V_{IH}	"H" Input Voltage	—	—	$0.8V_{DD}$	—	V_{DD}	V
V_{IL}	"L" Input Voltage	—	—	0	—	$0.2V_{DD}$	V
f_{OSC}	Oscillator Frequency	5V	$R_{OSC}=1M\Omega$	—	3	—	kHz
$R_{\overline{TE}}$	\overline{TE} Pull-high Resistance	5V	$V_{\overline{TE}}=0V$	—	1.5	3	$M\Omega$
R_{DATA}	D8~D11 Pull-high Resistance	5V	$V_{DATA}=0V$	—	1.5	3	$M\Omega$

Functional Description

Operation

The 3¹² series of encoders begin with a four (HT6010) or a one (HT6012/HT6014) word transmission cycle upon receipt of a transmission enable (\overline{TE} for the HT6010 or D8~D11 for the HT6012/HT6014, active low). This cycle will repeat itself as long as the transmission enable (\overline{TE} or D8~D11) is held low. Once the transmission enable returns high the encoder output completes its final cycle and then stops as shown below.

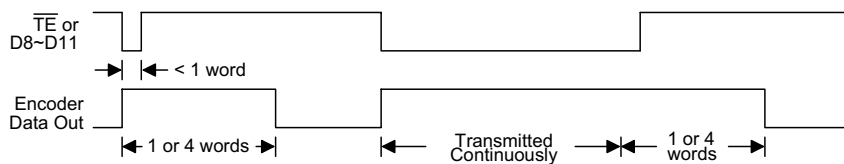

Transmission timing

Information word

An information word is composed of four periods as shown:

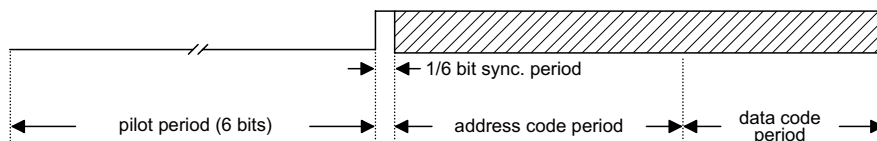

Composition of information

Address/data waveform

Each programmable address/data pin can be externally set to one of the following three logic states:

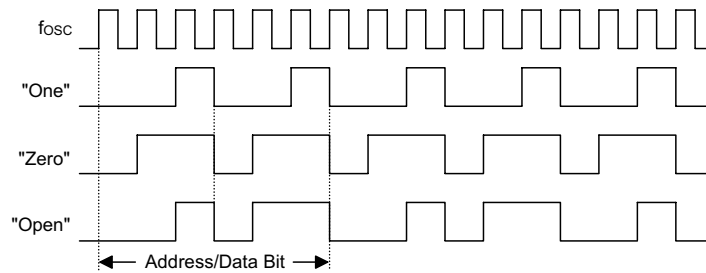

Address/Data bit waveform

The "Open" state data input is interpreted as logic high by the decoder since its output has only two states.

Address/data programming (preset)

The status of each address/data pin can be individually preset to a logic "high", "low", or "floating". If a transmission enable signal is applied, the encoder scans and transmits the status of the 12 bits of address/data serially in the order A0 to AD11 for the HT6010 and A0 to D11 for the HT6012/HT6014.

If the trigger signal is not applied, the chip only consumes a standby current which is less than 1µA (for V_{DD}=5V).

The address pins are usually preset so as to transmit data codes with their own particular security codes by the DIP switches or PCB wiring, while data is selected using push button or electronic switches.

Address/Data sequence

The following table provides the position of the address/data sequence for various models of the 3¹² series encoders. A correct device should be selected according to the requirements of the individual address and data.

Part No.	Address/Data Bits											
	0	1	2	3	4	5	6	7	8	9	10	11
HT6010	A0	A1	A2	A3	A4	A5	A6	A7	AD8	AD9	AD10	AD11
HT6012	A0	A1	A2	A3	A4	A5	A6	A7	A8	A9	D10	D11
HT6014	A0	A1	A2	A3	A4	A5	A6	A7	D8	D9	D10	D11

Transmission enable

For the \overline{TE} trigger type of encoders, transmission is enabled by applying a low signal to the \overline{TE} pin. But for the Data trigger type, it is enabled by applying a low signal to one of the data pins D8~D11.

Flowchart

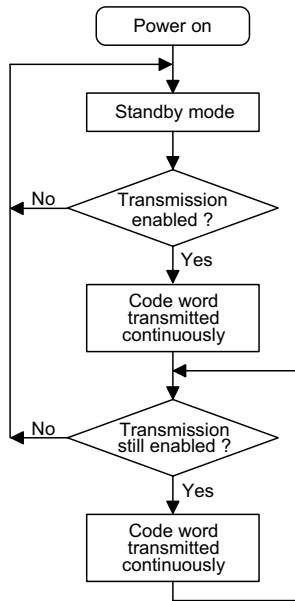

Note: D8~D11 are transmission enable of the HT6012/HT6014.

\overline{TE} is the transmission enable of the HT6010.

Oscillator frequency vs supply voltage

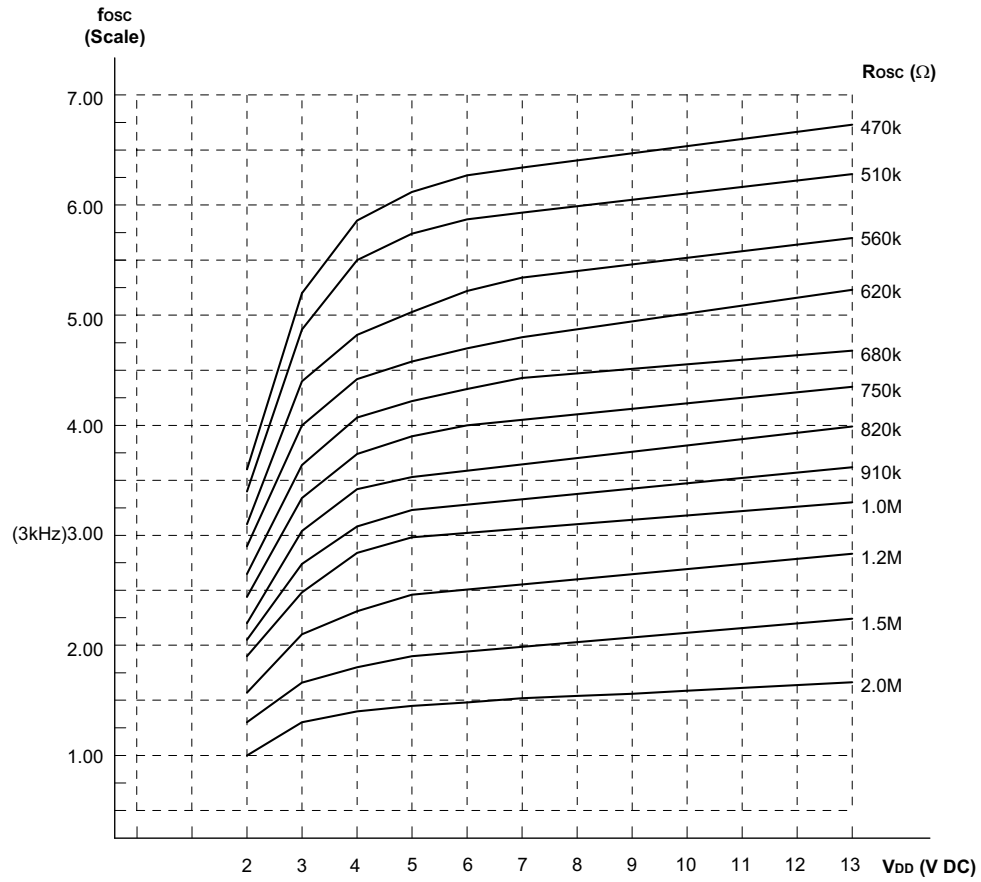

The recommended oscillator frequency is $f_{OSCD}(\text{decoder}) \cong 33 f_{OSCE}(\text{encoder})$

Application Circuits

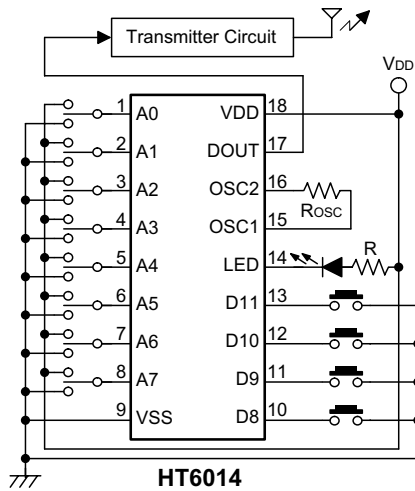
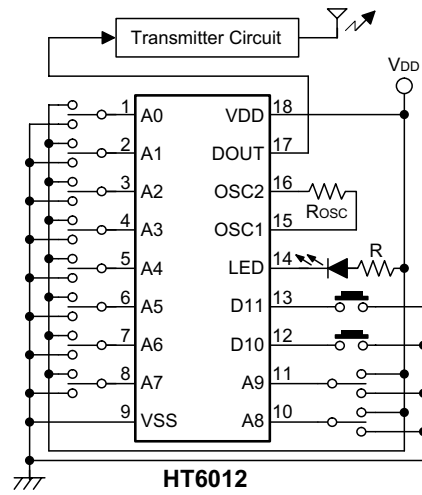
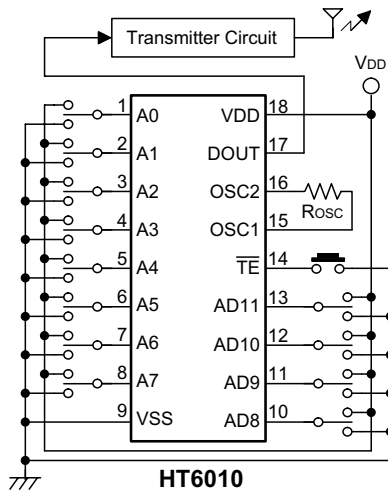

Note: Typical infrared diode: EL-1L2 (KODENSHI CORP.)
 Typical RF transmitter: JR-220 (JUWA CORP.)
 TX-99 (MING MICROSYSTEM, U.S.A.)

Holtek Semiconductor Inc. (Headquarters)

No.3 Creation Rd. II, Science-based Industrial Park, Hsinchu, Taiwan, R.O.C.
Tel: 886-3-563-1999
Fax: 886-3-563-1189

Holtek Semiconductor Inc. (Taipei Office)

5F, No.576, Sec.7 Chung Hsiao E. Rd., Taipei, Taiwan, R.O.C.
Tel: 886-2-2782-9635
Fax: 886-2-2782-9636
Fax: 886-2-2782-7128 (International sales hotline)

Holtek Semiconductor (Hong Kong) Ltd.

RM.711, Tower 2, Cheung Sha Wan Plaza, 833 Cheung Sha Wan Rd., Kowloon, Hong Kong
Tel: 852-2-745-8288
Fax: 852-2-742-8657

Copyright © 1999 by HOLTEK SEMICONDUCTOR INC.

The information appearing in this Data Sheet is believed to be accurate at the time of publication. However, Holtek assumes no responsibility arising from the use of the specifications described. The applications mentioned herein are used solely for the purpose of illustration and Holtek makes no warranty or representation that such applications will be suitable without further modification, nor recommends the use of its products for application that may present a risk to human life due to malfunction or otherwise. Holtek reserves the right to alter its products without prior notification. For the most up-to-date information, please visit our web site at <http://www.holtek.com.tw>.