

Features

- Complete Universal Serial Bus specs V1.0 compatibility
- Serial Bus Interface Engine (SIE)
- USB transceiver
- Microsoft 3D Intelli mouse and IBM PS/2 mouse compatible
- Supports three buttons (R, M, L) and three axes (X, Y, Z) input
- Z axis can support two kinds of scroller input (optomechanical and mechanical)
- Single chip solution especially for USB mouse function
- Halt function and wake-up feature reduce power consumption
- Plug and Play functions
- Minimal external components
- 6MHz crystal oscillator for system clock
- 18-pin DIP package

General Description

HT82M98A is a 3D mouse controller especially designed for USB and PS/2 applications. The HT82M98A can support the USB Standard Request as well as HID Class Request version 1.0 draft 4. It is compatible with Microsoft Intelli 3D PS/2 mouse. The X/Y axis photo input with built-in Holtek's special dynamic photo-input resistor and Z axis can support two kinds of

scroller input, namely; optomechanical and mechanical. It requires minimal external components to implement 3D USB plus PS/2 mouse. It can be briefly described as a Holtek 8-bit μ C with an on-chip USB interface logic. The USB is specified by the *Universal Serial Bus Specification V1.0*.

Block Diagram

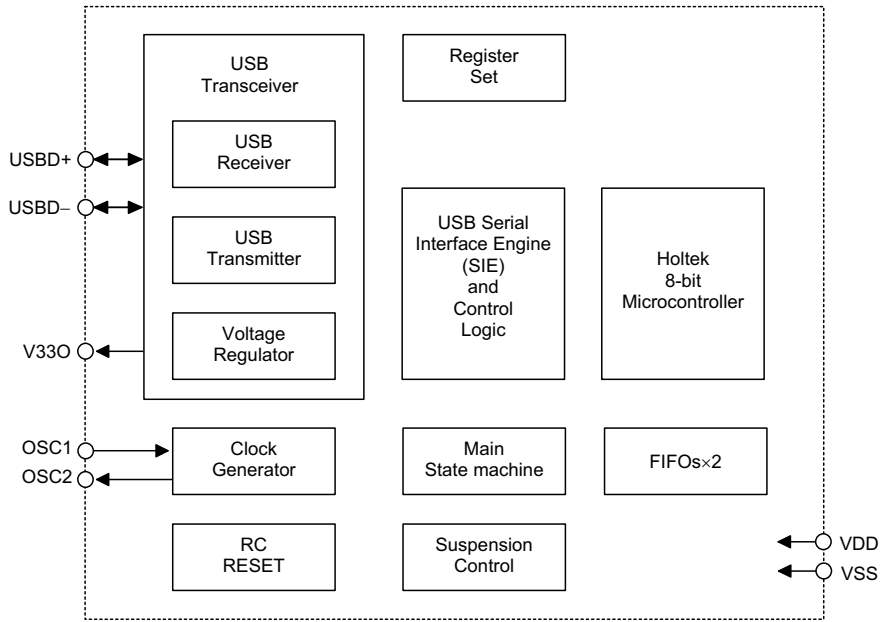

Pin Assignment

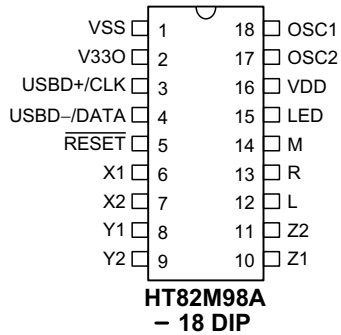

Pin Description

Pin No.	Pin Name	I/O	Description
USB Interface (2 pins)			
3	USBD+/CLK	I/O	USB data plus or PS2 Clock, F/W auto-detect USBD+ for USB, CLK for PS2
4	USBD-/DATA	I/O	USB data minus or PS2 Data, F/W auto-detect USB- for USB, DATA for PS2
General purpose I/O (9 pins)			
6, 7	X1, X2	I	X-axis photo input with built-in Holtek's special dynamic photo input resistor
8, 9	Y1, Y2	I	Y-axis photo input with built-in Holtek's special dynamic photo input resistor
10, 11	Z1, Z2	I	Z-axis input supports two kinds of scroller input; optomechanical and mechanical
12, 13, 14	L, R, M	I	Input ports with pull-high resistor. These pads can function as Left, Right and Middle button input lines.
Miscellaneous (7 pins)			
1	VSS	—	Negative power supply, ground.
2	V33O	O	3.3V voltage output
5	RESET	I	Chip reset input, low active
15	LED	I/O	Drives LED output
16	VDD	—	5V positive power supply
17	OSC2	O	6MHz OSC output
18	OSC1	I	6MHz OSC input

Absolute Maximum Ratings

Supply Voltage-0.3V to 6V Storage Temperature.....-50°C to 125°C
 μ C Input Voltage $V_{SS}-0.3V$ to $V_{DD}+0.3V$ Operating Temperature-25°C to 70°C
 USB Input Voltage $V_{SS}-0.3V$ to $V_{330}+0.3V$

Note: These are stress ratings only. Stresses exceeding the range specified under "Absolute Maximum Ratings" may cause substantial damage to the device. Functional operation of this device at other conditions beyond those listed in the specification is not implied and prolonged exposure to extreme conditions may affect device reliability.

D.C. Characteristics
 $T_a=25^\circ\text{C}$

Symbol	Parameter	Test Conditions		Min.	Typ.	Max.	Unit	
		V_{DD}	Conditions					
V_{DD}	Operating Voltage	—	—	4.5	—	5.5	V	
I_{DD}	Operating Current (Crystal OSC)	5V	No load, $f_{SYS}=6\text{MHz}$	USB mode	—	10	—	mA
				PS/2 mode	—	3	—	mA
I_{STB}	Standby Current	5V	No load, system HALT	—	—	250	μ A	
V_{IL1}	Input Low Voltage for I/O Ports	5V	—	0	—	1.0	V	
V_{IH1}	Input High Voltage for μ C I/O Ports	5V	—	3.5	—	5	V	
V_{IL2}	Input Low Voltage (RESET)	5V	—	0	—	1.5	V	
V_{IH2}	Input High Voltage (RESET)	5V	—	3.5	—	5	V	
V_{IH3}	Input High Voltage for USB I/O Ports	3.3V	—	2.8	—	3.6	V	
V_{POR}	Power on Reset V_{DD} Detection Voltage	5V	—	3.5	—	3.9	V	
I_{OL1}	Output Port Sink Current	5V	$V_{OL}=0.5V$	—	4	—	mA	
I_{OH1}	Output Port Source Current	5V	$V_{OL}=4.5V$	—	-4	—	mA	
I_{OL2}	Output Port Sink Current (LED)	5V	$V_{OL}=4.5V$	—	50	—	mA	

A.C. Characteristics

Ta=25°C

Symbol	Parameter	Test Conditions		Min.	Typ.	Max.	Unit
		V _{DD}	Conditions				
f _{SYS}	System Clock (Crystal OSC)	5V	—	0	6000	—	kHz
t _{WDTosc}	Watchdog Oscillator	—	—	80	100	120	μs
t _{WDT}	Watchdog Time-out Period (RC OSC)	—	—	768	1024	1280	ms
t _{PWRT}	Power-up Timer Period	—	—	—	10	—	ms
t _{OST}	Oscillation Start-up Timer Period	—	Power-up or wake-up form HALT	—	1024	—	t _{SYS}

 Note: t_{SYS}=1/f_{SYS}

Application Circuits

This application circuit is for reference only

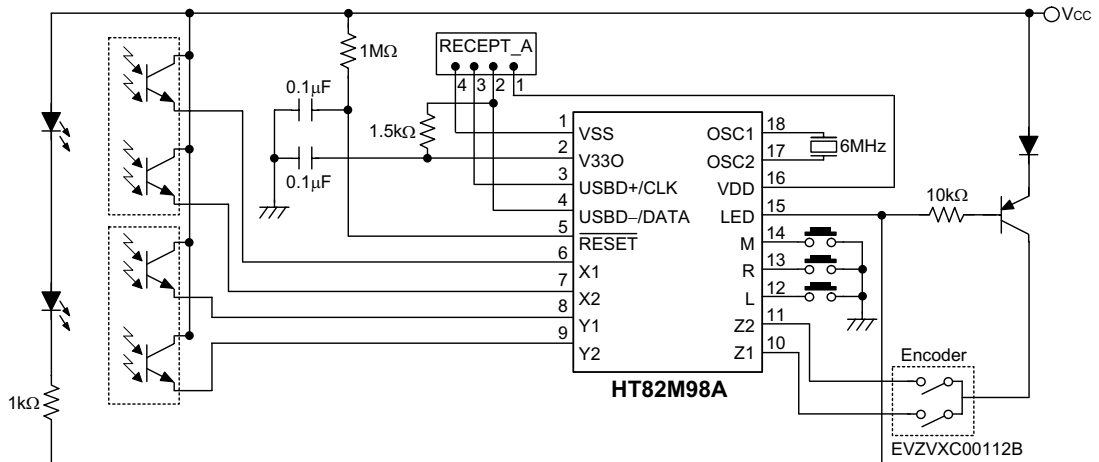
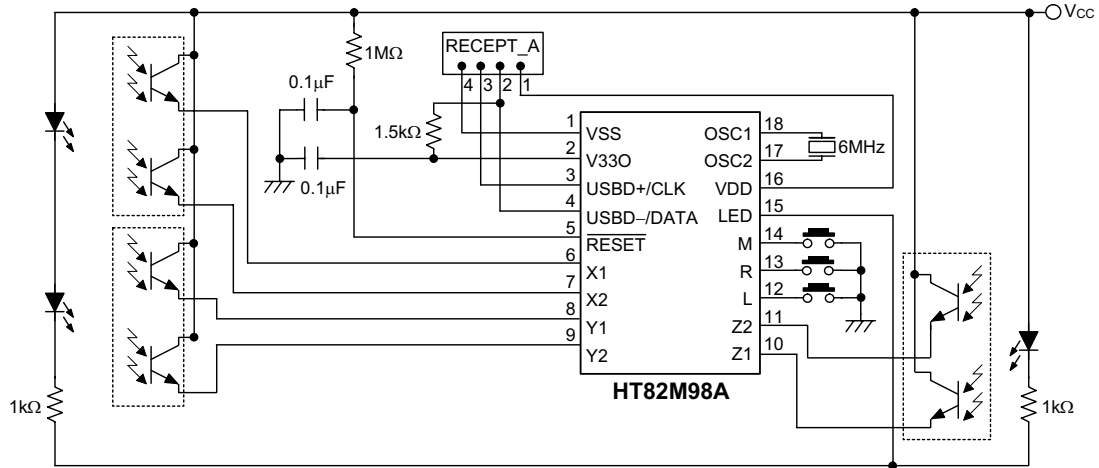

Holtek Semiconductor Inc. (Headquarters)

No.3 Creation Rd. II, Science-based Industrial Park, Hsinchu, Taiwan, R.O.C.
Tel: 886-3-563-1999
Fax: 886-3-563-1189

Holtek Semiconductor Inc. (Taipei Office)

5F, No.576, Sec.7 Chung Hsiao E. Rd., Taipei, Taiwan, R.O.C.
Tel: 886-2-2782-9635
Fax: 886-2-2782-9636
Fax: 886-2-2782-7128 (International sales hotline)

Holtek Semiconductor (Hong Kong) Ltd.

RM.711, Tower 2, Cheung Sha Wan Plaza, 833 Cheung Sha Wan Rd., Kowloon, Hong Kong
Tel: 852-2-745-8288
Fax: 852-2-742-8657

Copyright © 2000 by HOLTEK SEMICONDUCTOR INC.

The information appearing in this Data Sheet is believed to be accurate at the time of publication. However, Holtek assumes no responsibility arising from the use of the specifications described. The applications mentioned herein are used solely for the purpose of illustration and Holtek makes no warranty or representation that such applications will be suitable without further modification, nor recommends the use of its products for application that may present a risk to human life due to malfunction or otherwise. Holtek reserves the right to alter its products without prior notification. For the most up-to-date information, please visit our web site at <http://www.holtek.com.tw>.