

## 2.8 Second Enhanced Tone Voice

### Features

- Operating voltage: 2.4V~5.0V
- Low standby current (1 $\mu$ A Typ.)
- Voice/sound effect/simple melody output
- 2.8-second voice capacity
- 32 tone sections
- 16 words for each tone section
- Current type D/A output
- Mask options
  - Pull-high resistor: 20k $\Omega$ /50k $\Omega$ /100k $\Omega$
  - KEY1: Direct or sequential/random key
  - Trigger mode: Retriggerable/Non-retriggerable
  - KEY1 play normal mode or twin mode  
Normal mode: one group for KEY1
- Twin mode: Two groups for KEY1
  - 8 direct key or 4 $\times$ 4 MATRIX keys
  - Two-page trigger
  - Key debounce time: 22ms/45ms
  - Trigger function:
    - Level hold/one shot/level trigger
  - FLAG1, FLAG2 outputs:
    - 3Hz/sound level/busy/6Hz/endlp
  - Melody/tone decay time:
    - 2 sec/1 sec/0.5 sec/0.25 sec
  - Four kinds of envelope shapes for melody
- Tone shape: tone+2kHz/noise/tone/silence
- Tempo: 16ms/section~1 sec/section
- Dice form or 16-pin DIP

### Applications

- Toys
- Alarm clocks
- Public address system
- Alert & warning system
- Sound effect generators
- Voice interface products

### General Description

The HT812L0 is a single chip PCM voice and sound effect synthesizer. It provides 2.8 seconds of voice capacity at a 6kHz sampling rate ( $F_{SR}=6\text{kHz}$ ) and 32 sections of sound effects/simple melodies. A maximum of 8 keys or 4 $\times$ 4 MATRIX are available. Of the 8 keys or 4 $\times$ 4

MATRIX, KEY1 can be optioned as a direct or sequential/random key, so that it can play an interlaced voice/sound effect/simple melody and generate various special sound effects for toys and sound effect generator applications.

### Pin Assignment

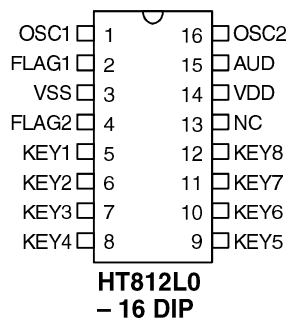

**Block Diagram**

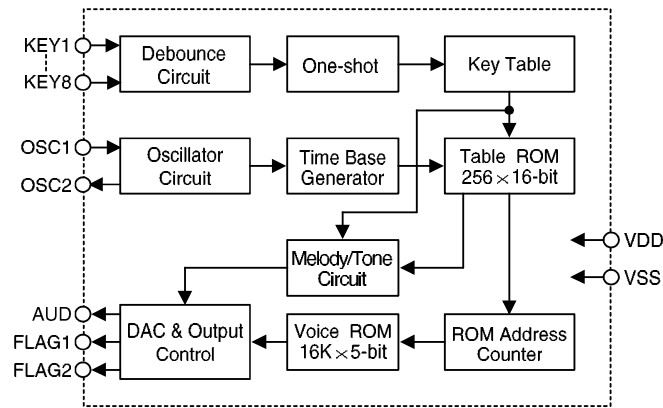

**Pad Coordinates**

Unit:  $\mu\text{m}$

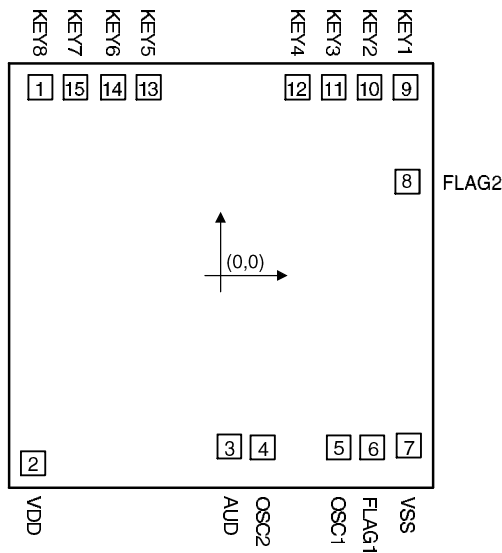

Pad No.	X	Y
1	-822.65	828.40
2	-855.15	-900.10
3	26.65	-823.00
4	176.65	-828.00
5	516.25	-827.60
6	666.25	-827.60
7	830.65	-819.30
8	824.55	394.80
9	816.55	828.40
10	654.75	828.40
11	493.55	828.40
12	331.75	828.40
13	-338.55	828.40
14	-497.15	828.40
15	-664.15	828.40

Chip size:  $1970 \times 2120 (\mu\text{m})^2$

\*The IC substrate should be connected to VSS in the PCB layout artwork.

**Pad Description**

Pad No.	Pad Name	I/O	Internal Connection	Description
2	VDD	I	—	Positive power supply
3	AUD	O	PMOS Open Drain	Voice/tone output driving an external transistor
4	OSC2	O	—	Oscillator output pin
5	OSC1	I	—	Oscillator input pin
6	FLAG1	O	NMOS Open Drain	3Hz flash/busy output/6Hz (by code option), active low
7	VSS	I	—	Negative power supply (GND)
8	FLAG2	O	NMOS Open Drain	3Hz flash/busy output/ENDP/sound level display (by mask option), active low
9~15, 1	KEY1~KEY8	I	Pull-High	Trigger key, active low. KEY1 can be optioned as a direct or sequential/random key, the 7 keys as direct keys only or by mask option as 4×4 matrix key

**Absolute Maximum Ratings\***

Supply Voltage ..... -0.3V to 6V      Storage Temperature..... -50°C to 125°C  
 Input Voltage.....  $V_{SS}-0.3V$  to  $V_{DD}+0.3V$       Operating Temperature..... -20°C to 70°C

\*Note: These are stress ratings only. Stresses exceeding the range specified under “Absolute Maximum Ratings” may cause substantial damage to the device. Functional operation of this device at other conditions beyond those listed in the specification is not implied and prolonged exposure to extreme conditions may affect device reliability.

**Electrical Characteristics**

(Ta=25°C)

Symbol	Parameter	Test Conditions		Min.	Typ.	Max.	Unit
		V <sub>DD</sub>	Conditions				
V <sub>DD</sub>	Operating Voltage	—	—	2.4	—	5.0	V
I <sub>OP</sub>	Operating Current	3V	No load, f <sub>OSC</sub> =96kHz	—	200	400	μA
I <sub>STB</sub>	Standby Current	3V	—	—	1	3	μA
I <sub>O</sub>	Max. AUD Output Current	3V	V <sub>OH</sub> =0.6V	-1.5	-2	—	mA
I <sub>OL</sub>	FLAG Sink Current	3V	V <sub>OL</sub> =0.3V	2	3	—	mA
V <sub>IH</sub>	“H” Input Voltage	—	—	0.8V <sub>DD</sub>	—	V <sub>DD</sub>	V
V <sub>IL</sub>	“L” Input Voltage	—	—	0	—	0.2V <sub>DD</sub>	V
f <sub>OSC</sub>	Oscillating Frequency	3V	—	—	96	—	kHz

## Functional Description

The HT812L0 is a voice and melody synthesizer LSI with 2.8-second voice capacity at 6kHz sampling rate and 32 sections of sound effects/simple melodies. The 2.8 seconds of voice capacity can be divided into sections of arbitrary length. Notice that the silence length is not included in the memory. As for the 32-section tone table, various sound effects can be generated.

The HT812L0 provides a maximum of 8 keys, 2 status indicator driving pins and a current type D/A output. Of the 8 keys, only KEY1 can be optioned as a sequential (random) or a direct key. The remaining 7 keys (KEY2~KEY8) are used as direct keys exclusively or by mask option as matrix key input (4×4).

### Voice section and group

- Voice section

The total synthesized voice contents (2.8 seconds) can be partitioned into the desired number of sections depending on the size of the ROM table. The length of each section is decided by the requirements of the voice contents. For example:

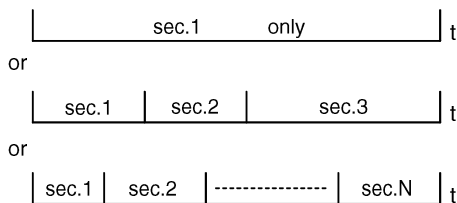

- Melody section

The HT812L0 provides 32 melody/tone sections at maximum. Each section is composed of 16 tone codes and each code stands for a period of tone output. The tone frequency envelope shape, envelope length and speed of tone (tempo) are all programmable. There-

fore, a variety of sound effects and melodies can be generated.

- Group

A group can consist of one or more sections and be made up solely of voice or melody or a combination of both sounds. The same voice and melody sections can appear in different groups, as shown below:

Group 1	sec.1 + sec.2 + Melody.1 + sec.5
Group 2	sec.3 + Melody.2 + Melody.1
Group 3	sec.2 + sec1
Group 4	sec.2 + Melody.3 + sec.4
:	:
:	:
Group 16	None

The maximum amount of groups included in the HT812L0 is decided by the setting of KEY1, as described in the following:

- KEY1 as a direct key

When KEY1 is selected as a direct key, the maximum amount of groups included in the HT812L0 is 16. And the sum of the voice and melody sections of the 16 groups has to be less than 256. When one of the 8 keys is triggered, the sections of the corresponding group is played in sequence.

- KEY1 as a sequential (or random) key

When KEY1 is set as a sequential (or random) key, the maximum amount of groups included in the HT812L0 can be defined by the user under the condition that the total number of the voice and melody sections of the groups is less than 256. Of the 8 keys, only KEY1 can be made up of more than one group. The remaining 7 keys (KEY2~KEY8) comprised one group only.

For example:

Group 1-1	sec.1 + sec.4
Group 1-2	sec.3 + Melody.1
:	:
:	:
Group 1-N	sec.2 + sec1 + Melody.1 + sec.1
Group 2	Melody.1 + Melody.3 + sec.1
Group 3	sec.2 + sec.3
:	:
:	:
Group 16	sec.1 + Melody.2 + Melody.3

Each time KEY1 is triggered, the corresponding group is played in sequence. When the last group is finished the KEY1 group sequence will be repeated by successive trigger inputs.

- KEY1 as a two-group key (TWIN mode). KEY1 can play two groups, if KEY1 is held down, the group 1 can be played repeatedly till KEY1 is released, and immediately then the group 2 will be played one cycle by the rising edge of KEY1. (see Figure 1)

**Key operation functions**

KEY1~KEY8 all function as trigger keys. By mask option, the HT812L0 provides three trigger functions for the 8 keys, namely: "one shot", "level hold" and "level trigger". All of the three trigger functions can be optioned as retriggerable or non-retriggerable.

• Trigger function

• One shot

When one of the 8 keys (KEY1~KEY8) is pressed and held down, or pressed momentarily, the group corresponding to that held or pressed key will play once.

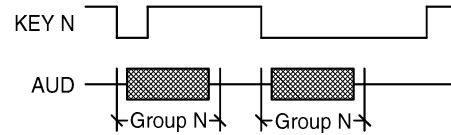

• Level hold

When one of the 8 keys is triggered, the group corresponding to the triggered key will keep playing till that key is released.

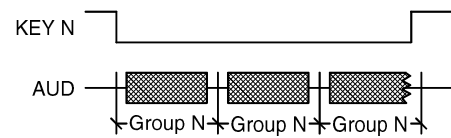

• Level trigger

When one of the 8 keys is pressed and held down, the corresponding group will keep playing. Once the pressed key is released, the group will not stop till the included sections are all completed.

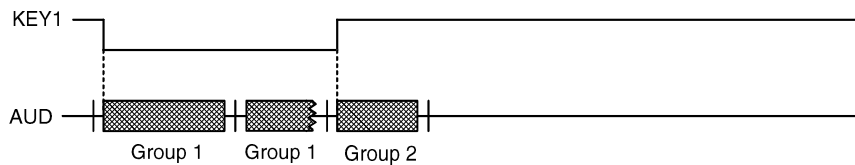
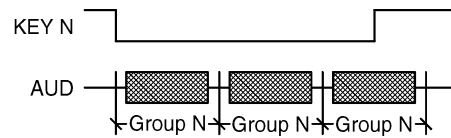

Figure 1 One key two groups function (TWIN mode)

• Trigger mode

• Retriggerable

When a group is playing corresponding to a momentarily triggered key, any further key input can terminate the currently playing group and start playing the group corresponding to the newly triggered key. However, if a group of KEY1~KEY8 is playing but the key corresponding to the playing group is still held down, whether the currently playing group will be forcefully stopped or not, depends on the key priority, namely;

KEY1>KEY2> KEY3>KEY4...>KEY8.

• Non-retriggerable

In the non-retriggerable mode, when one of the 8 keys (KEY1~KEY8) is pressed, the corresponding group will not start playing till the currently playing group is completed.

**AUD**

The AUD pin is a PMOS open drain structure. It outputs voice and tone signals to drive a speaker through an external NPN transistor when the chip is active. However, the AUD pin becomes a floating output when the chip is in the standby state.

The 8050 type transistor with  $h_{FE} \approx 150$  is recommended for an output driver.

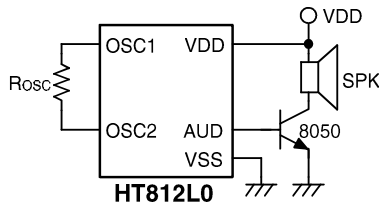

**System oscillator**

The HT812L0 has an RC oscillator which requires only one external resistor for normal applications. The oscillator frequency is typically 96kHz for an external resistor.

The oscillator is turned on when triggered by a key input. After playing, the oscillator is turned off and the chip goes into the standby state.

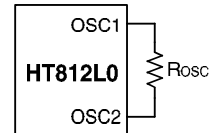

**Mask options**

The HT812L0 provides the following mask options for different applications. Before manufacture, all of the options must be defined to enable a proper system of operation.

- Mask options for keys:
  - Keys debounce time: 22ms/45ms
  - Pull-high resistor: 20kΩ/50kΩ/100kΩ
  - Trigger function: Level hold/One shot/Level trigger
  - Direct key or matrix key (4×4)
  - Normal or two pages (Direct key=16 trigger, matrix key=32 trigger)
- FLAG2 outputs: 3Hz/sound level/busy/endlp (Mask option)
- 3Hz flash

When voices are playing, the FLAG LED flashes with a 3Hz rate. The LED turned on duty is 25%.

In the standby state, the FLAG pin is a floating output.

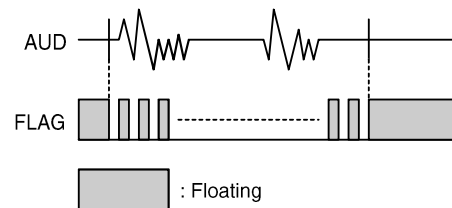

• **Busy output**

When voices are playing, the FLAG pin is turned low and the FLAG LED is switched on. Once the voice output is terminated, FLAG becomes a floating output and the FLAG LED is switched off.

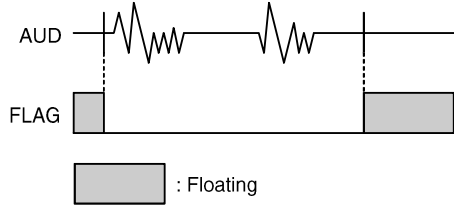

• **Sound level display**

The brightness of the LED will vary with the volume in the voice output state.

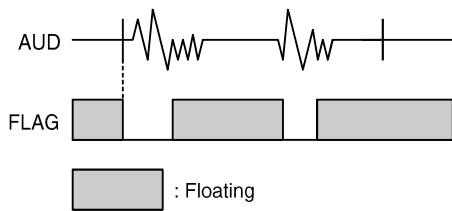

**Programmable items**

- Voice section
- Tempo
- Decay time and envelope shape
  - There are four programmable envelope shapes and decay time to smooth out tone and melody sounds.
  - Decay time: 2 sec, 1 sec, 0.5 sec, 0.25 sec
  - Tone shape: tone+2kHz, noise, tone, silence
- Trigger mode: retriggerable/non-retriggerable
- REPEAT function
- FLAG1 outputs, 3Hz/6Hz/Busy/Off

Application Circuits

Direct key application

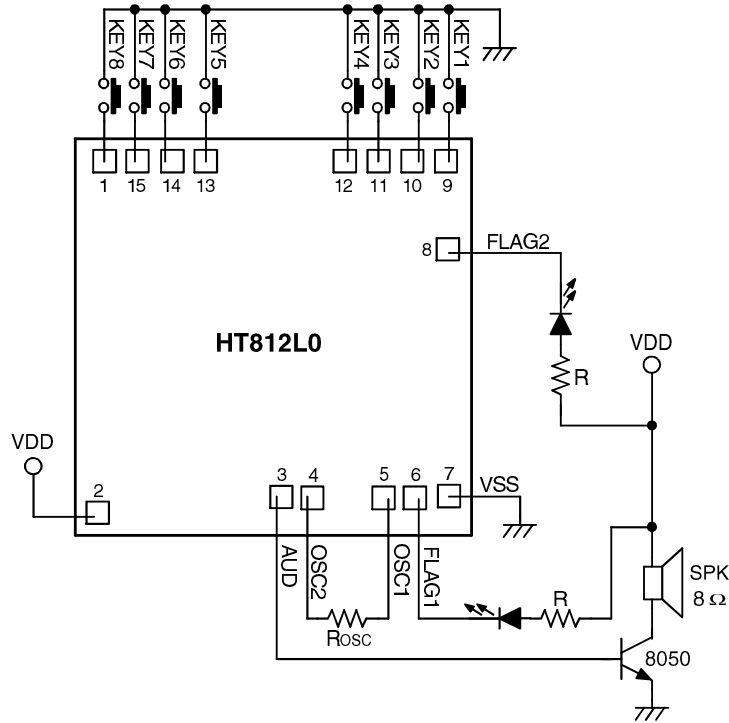

\* The IC substrate should be connected to VSS in the PCB layout artwork.

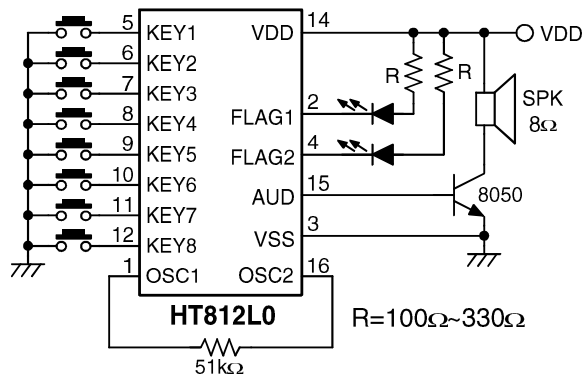



Key Matrix (4x4) application

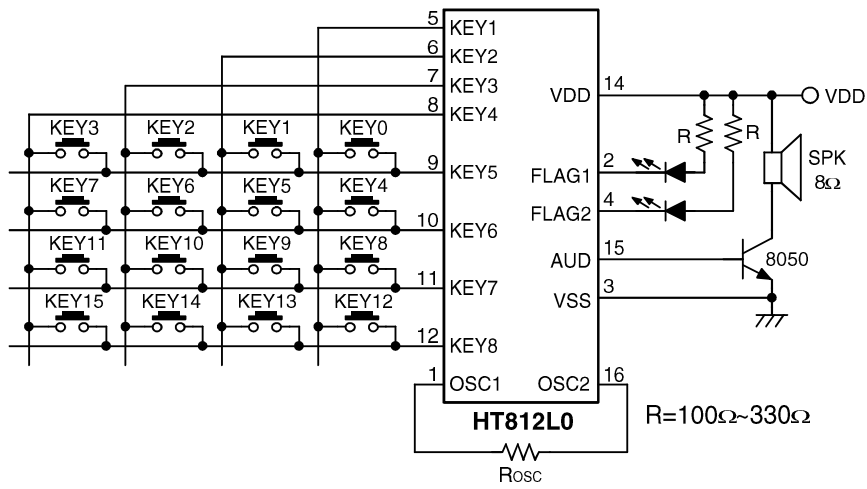

Standard Item List

Item	Name	Rosc	Remarks
HT812LA	DJDRUM	436kΩ	Matrix key and option page