

Patent Number: 84545 (R.O.C.)
Patent Pending: 08/214, 079 (U.S.A.)

Features

- Operating voltage: 1.2V~1.7V
- Low operating current: 3 μ A (typ.)
- Dialing number and conversation time display
- Conversation timer (59 mins and 59 secs max.)
- 8 or 10-digit LCD display driver; 3V, 1/2 bias, 1/3 duty (8-digit hand-held calculator LCD used for 8-digit applications)
- Real time clock with stopwatch
- Built-in dialer interface
- 12-hour or 24-hour format
- Two-button sequential operation for real time clock setting
- Uses 32768Hz crystal

Applications

- Timers, clocks, watches
- LCD display drivers
- Telephone display interface
- Instrument display

General Description

The HT1611C is a CMOS chip designed for dialer interfaces driving 8 or 10-digit LCDs. Various functions, such as real time clock, dialing number and conversation time display are provided.

The real time is displayed by default. When answering a telephone call, the timer is activated to tell users how long the conversation has taken. After the telephone is hung up, the total conversation time is shown for about 5

seconds and then the real time is displayed again. When making a phone call, the HT1611C receives the dialing data from the dialer and displays the phone number from left to right on the LCD. However, if there is no dialing action within 10 seconds, it restarts the timer again. By adding a TIMER key, the HT1611C can provide a stopwatch function and timer reset/hold functions (for details, refer to the functional description).

Block Diagram

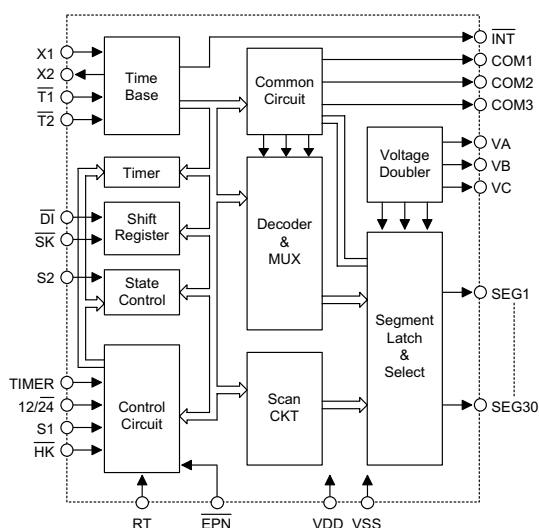

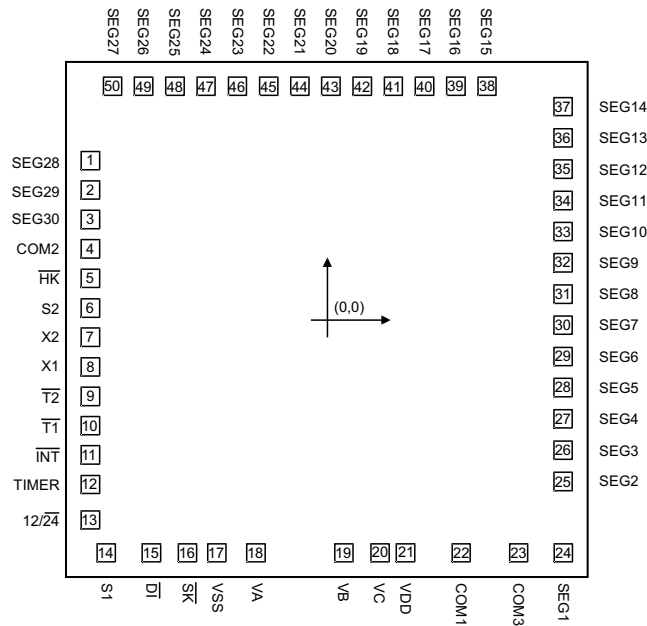
Pad Assignment

Chip size: 122.5 × 124.9 (mil)²

* The IC substrate should be connected to VDD in the PCB layout artwork.

Pad Coordinates

Unit: mil

Pad No.	X	Y	Pad No.	X	Y	Pad No.	X	Y
1	-55.73	37.50	18	-16.79	-54.72	35	55.46	35.51
2	-55.73	30.58	19	3.90	-54.72	36	55.46	42.86
3	-55.73	23.66	20	12.43	-54.72	37	55.46	50.20
4	-55.73	16.77	21	18.40	-54.72	38	37.60	55.02
5	-55.73	9.85	22	31.48	-54.72	39	30.26	55.02
6	-55.73	2.85	23	45.02	-54.72	40	22.91	55.02
7	-55.73	-4.07	24	55.50	-54.72	41	15.57	55.02
8	-55.73	-11.00	25	55.46	-37.96	42	8.22	55.02
9	-55.73	-17.96	26	55.46	-30.58	43	0.88	55.02
10	-55.73	-24.84	27	55.46	-23.24	44	-6.46	55.02
11	-55.73	-31.73	28	55.46	-15.89	45	-13.81	55.02
12	-55.73	-38.65	29	55.46	-8.55	46	-21.15	55.02
13	-55.73	-47.03	30	55.46	-1.21	47	-28.50	55.02
14	-52.02	-54.72	31	55.46	6.14	48	-35.84	55.02
15	-41.35	-54.72	32	55.46	13.48	49	-43.18	55.02
16	-32.86	-54.72	33	55.46	20.83	50	-50.53	55.02
17	-25.97	-54.72	34	55.46	28.17			

Pad Description

Pad Name	I/O	Internal Connection	Description
SEG1~SEG30	O	CMOS OUT	LCD segment signal output pads
COM1~COM3	O	CMOS OUT	LCD common signal output pads
$\overline{\text{HK}}$	I	CMOS IN Pull-high	Hook switch detector input Active low
S2	I	CMOS IN Pull-low	Clock adjusting switch Active high
X2	O	OSCILLATOR	32768Hz crystal oscillator output
X1	I	OSCILLATOR	32768Hz crystal oscillator input
$\overline{\text{T2}}$	I	CMOS IN Pull-high	Test pad (connected to VSS for production test)
$\overline{\text{T1}}$	I	CMOS IN Pull-high	Test pad (connected to VSS for production test)
$\overline{\text{INT}}$	O	NMOS OUT	Interrupt output, 2Hz (default) or 16Hz (by mask option)
TIMER	I	CMOS IN Pull-low	Timer reset and start/hold toggle control input pad
12/24	I	CMOS IN Pull-low	12-hour or 24-hour format option pad, connected to VDD for 12-hour format
S1	I	CMOS IN Pull-low	Clock setting switch Active high
$\overline{\text{DI}}$	I	CMOS IN Pull-high	Serial data input pad (connected to the dialer) Data should be valid at the falling edge of SK
$\overline{\text{SK}}$	I	CMOS IN Pull-high	Clock input pad (connected to the dialer)
VA	O	CMOS OUT	Voltage doubler, connected to the external capacitor
VB	O	CMOS OUT	Voltage doubler, connected to the external capacitor
VC	O	CMOS OUT	Voltage doubler, connected to the external capacitor
VDD	—	—	Positive power supply
VSS	—	—	Negative power supply, ground

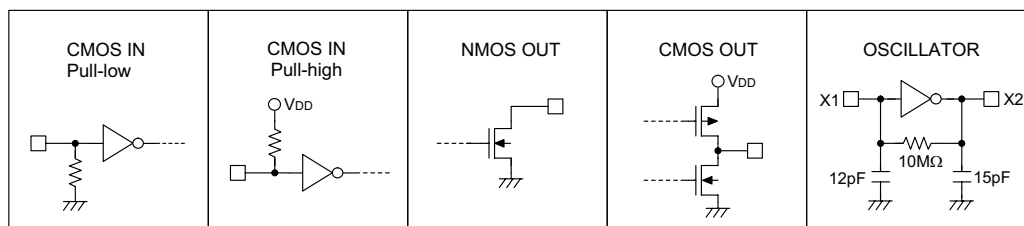
Approximate internal connection circuit

Absolute Maximum Ratings

Supply Voltage	-0.3V to 5V	Storage Temperature	-50°C to 125°C
Input Voltage	$V_{SS}-0.3$ to $V_{DD}+0.3$	Operating Temperature	-20°C to 75°C

Note: These are stress ratings only. Stresses exceeding the range specified under "Absolute Maximum Ratings" may cause substantial damage to the device. Functional operation of this device at other conditions beyond those listed in the specification is not implied and prolonged exposure to extreme conditions may affect device reliability.

Electrical Characteristics
 $f_{OSC}=32768\text{Hz}$, $T_a=25^\circ\text{C}$

Symbol	Parameter	Test Conditions		Min.	Typ.	Max.	Unit
		V_{DD}	Conditions				
V_{DD}	Operating Voltage	—	—	1.2	1.5	1.7	V
V_{IL}	Input Low Voltage	1.2V~1.7V	—	V_{SS}	—	$0.2V_{DD}$	V
V_{IH}	Input High Voltage	1.2V~1.7V	—	$0.8V_{DD}$	—	V_{DD}	V
I_{STB}	Standby Current	1.5V	$V_{HK}=\text{Floating (or } V_{DD})$	—	0.1	1	μA
I_{DD}	Operating Current	1.5V	No load	—	3	10	μA
I_{OL}	Output Sink Current of $\overline{\text{INT}}$	1.5V	$V_O=0.3\text{V}$	500	1000	—	μA
t_A	Data Setup Time	1.5V	—	1	—	—	μs
t_B	Data Hold On Time	1.5V	—	2	—	—	μs
t_C	Inter Digit Time	1.5V	—	5	—	—	μs
t_{DB}	Debounce Time (HK, S1, S2, TIMER)	1.5V	—	—	31.25	—	ms
R_{HI}	Pull-high Resistance (HK, DI, SK)	1.5V	$V_{IN}=0\text{V}$	—	1	—	$\text{M}\Omega$
R_{LO}	Pull-low Resistance (TIMER, S1, S2, 12/24)	1.5V	$V_{TIMER}=1.5\text{V}$	—	5	—	$\text{M}\Omega$
f_{OSC}	System Frequency	1.5V	Crystal=32768Hz	—	32768	—	Hz

Functional Description

Operational flow chart

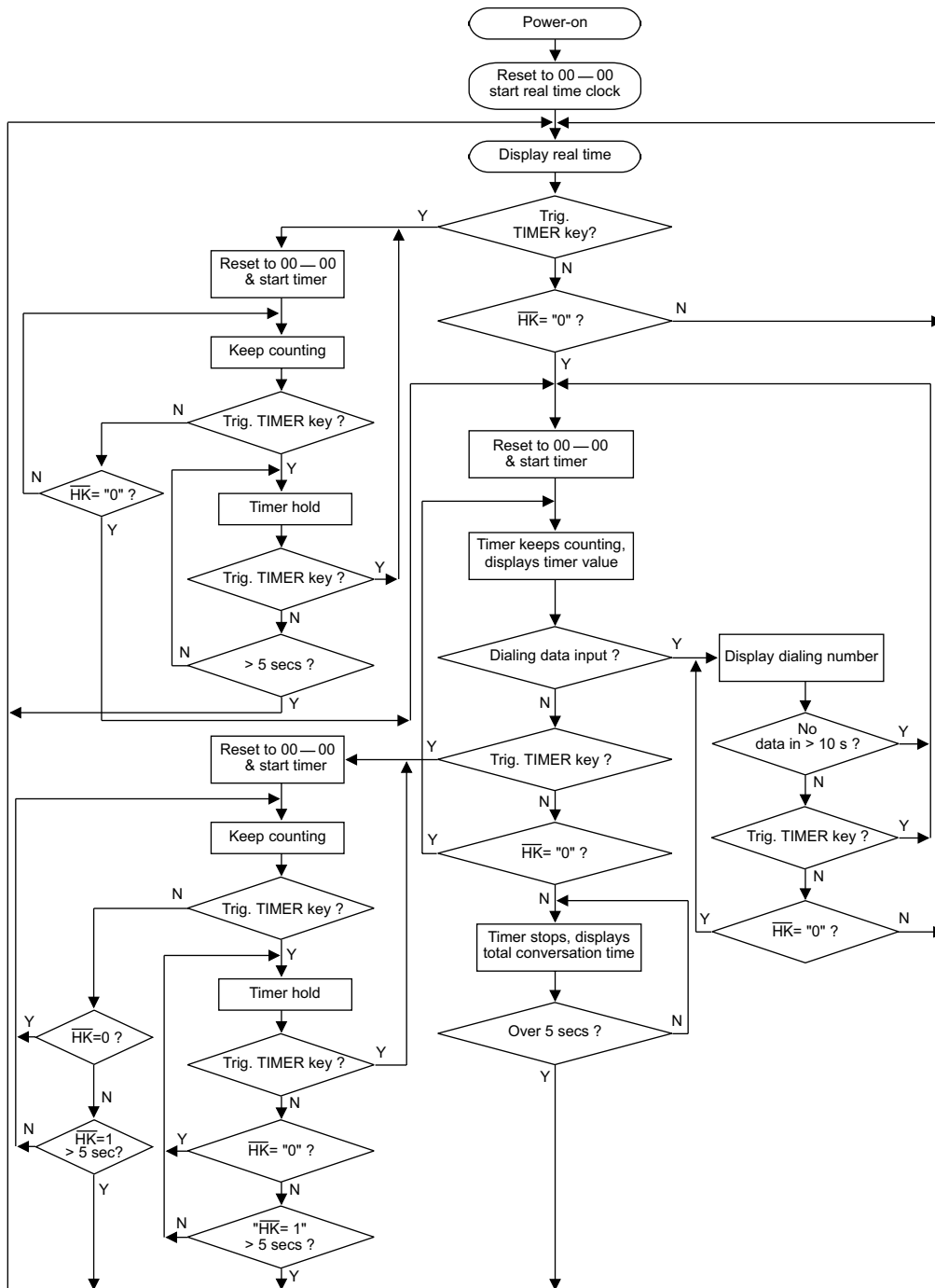

On-hook & off-hook

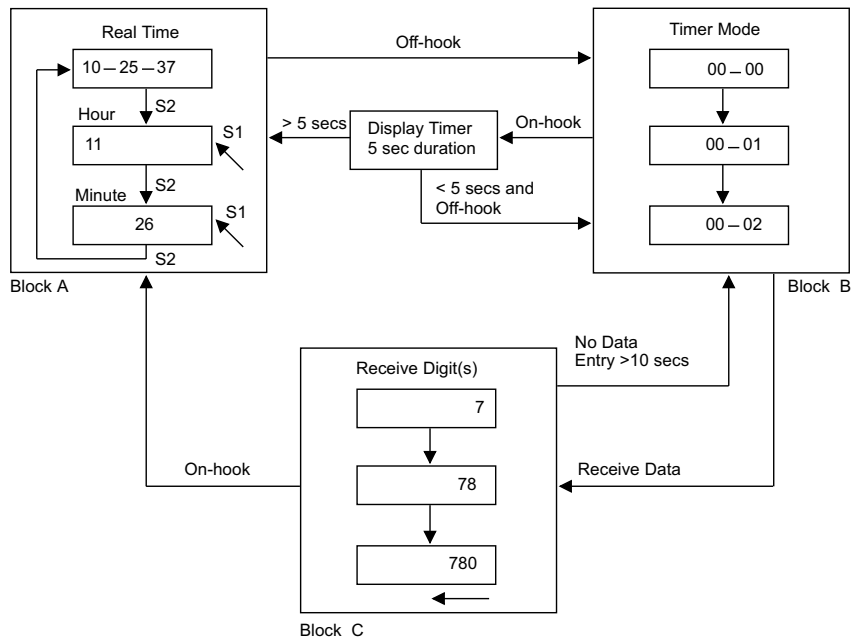

Note: Block A shows the switches S1 and S2 that are used for setting and selecting.

Block B illustrates a timer mode when Off-hook; timer resets and starts to count the conversation time.

In Block C, the dialing data is received and displayed on the LCD from left to right after Off-hook. When the entry interval is over 10 seconds, it resets the timer and starts to count.

TIMER key function

The TIMER key is used to start/stop the timer (toggle). In real time mode, it can perform a stopwatch function.

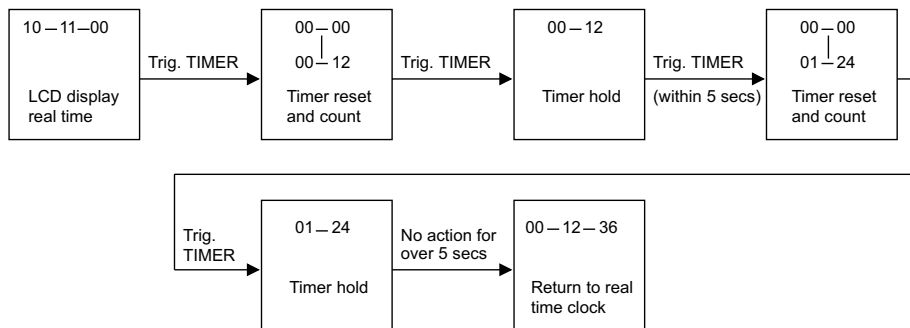

In the conversation timer mode, it can reset or hold the timer.

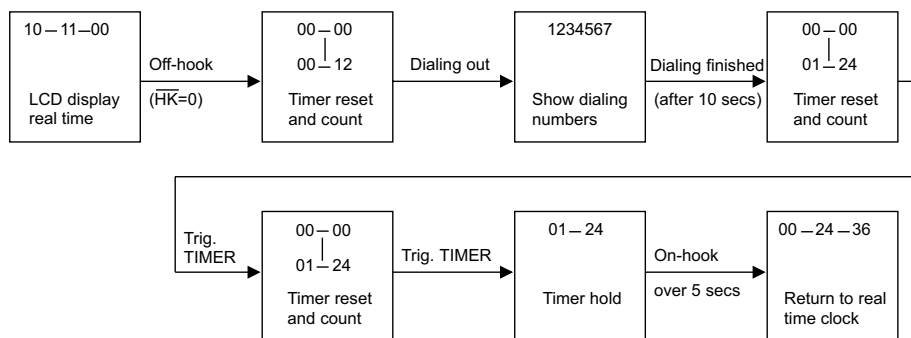

Data & Timing

- For telephone application

The HT1611C is designed to display telephone numbers derived from the HT93XXX series telephone dialers. The corresponding data is illustrated in the following table.

Key-In	Data Code				Display
	b3	b2	b1	b0	
Blank	0	0	0	0	Blank
1	0	0	0	1	1
2	0	0	1	0	2
3	0	0	1	1	3
4	0	1	0	0	4
5	0	1	0	1	5
6	0	1	1	0	6
7	0	1	1	1	7
8	1	0	0	0	8
9	1	0	0	1	9
0	1	0	1	0	0
*	1	1	0	1	*
#	1	1	0	0	#
F	1	0	1	1	F
P	1	1	1	0	P
	1	1	1	1	-

- For instrument or μ C application

The HT1611C is also capable of displaying BCD data generated from instrument or a μ C system. The corresponding data and timing is shown in the Data latch timing. Before the data is transmitted to the HT1611C, the $\overline{\text{HK}}$ pin should be pulled-low or continuously kept low. The HT1611C is then ready to receive the data. At the falling edge of the clock the data is shifted in to the IC. After all the data is sent to the HT1611C, the SK pin is set low to avoid switching to the timer mode.

- Data latch timing

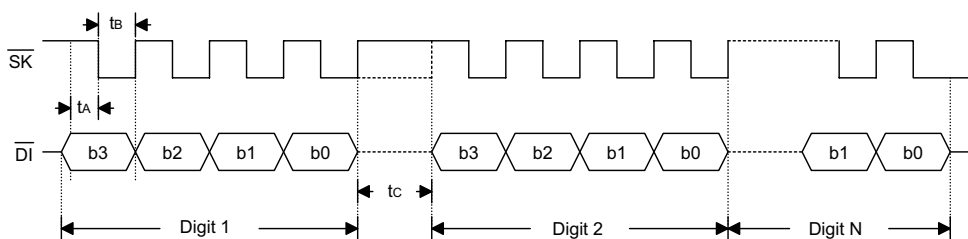

Application Circuits

For telephone interfacing (with batteries)

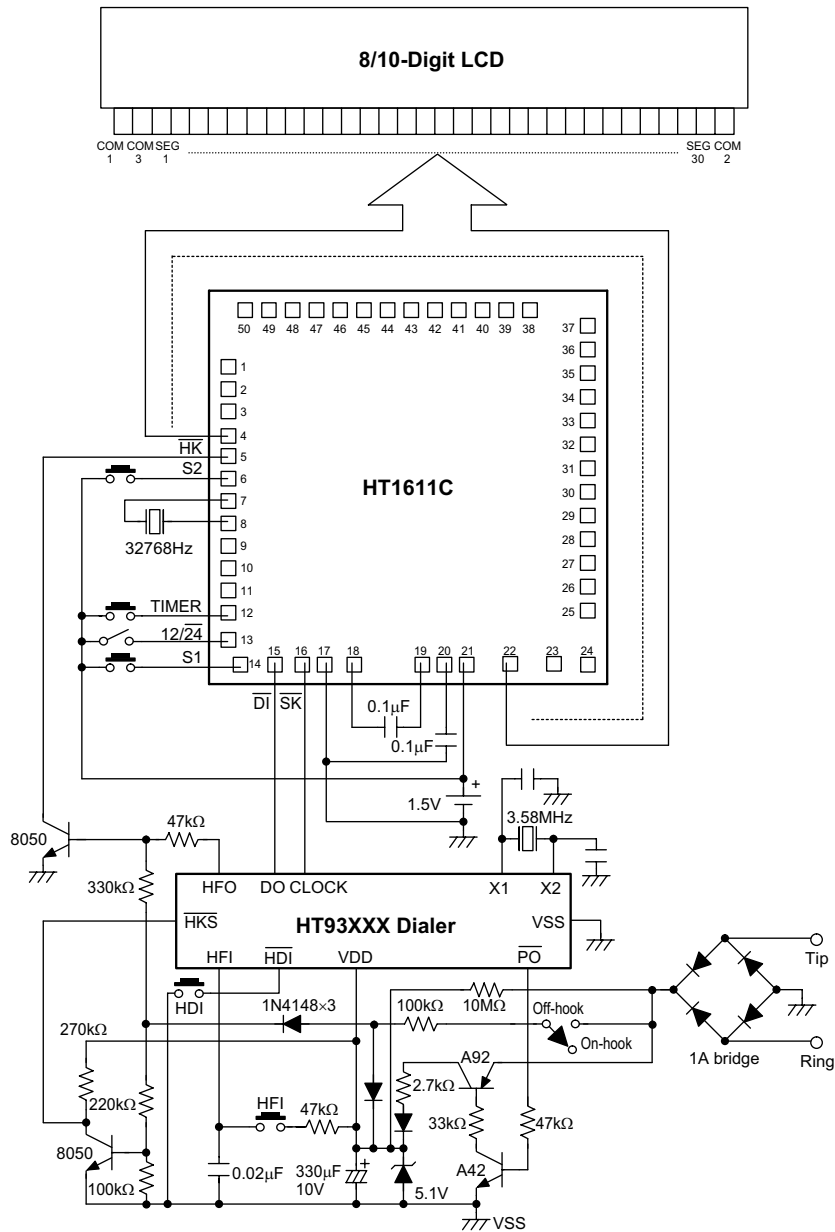

* The IC substrate should be connected to VDD in the PCB layout artwork.

For telephone interfacing (without batteries)

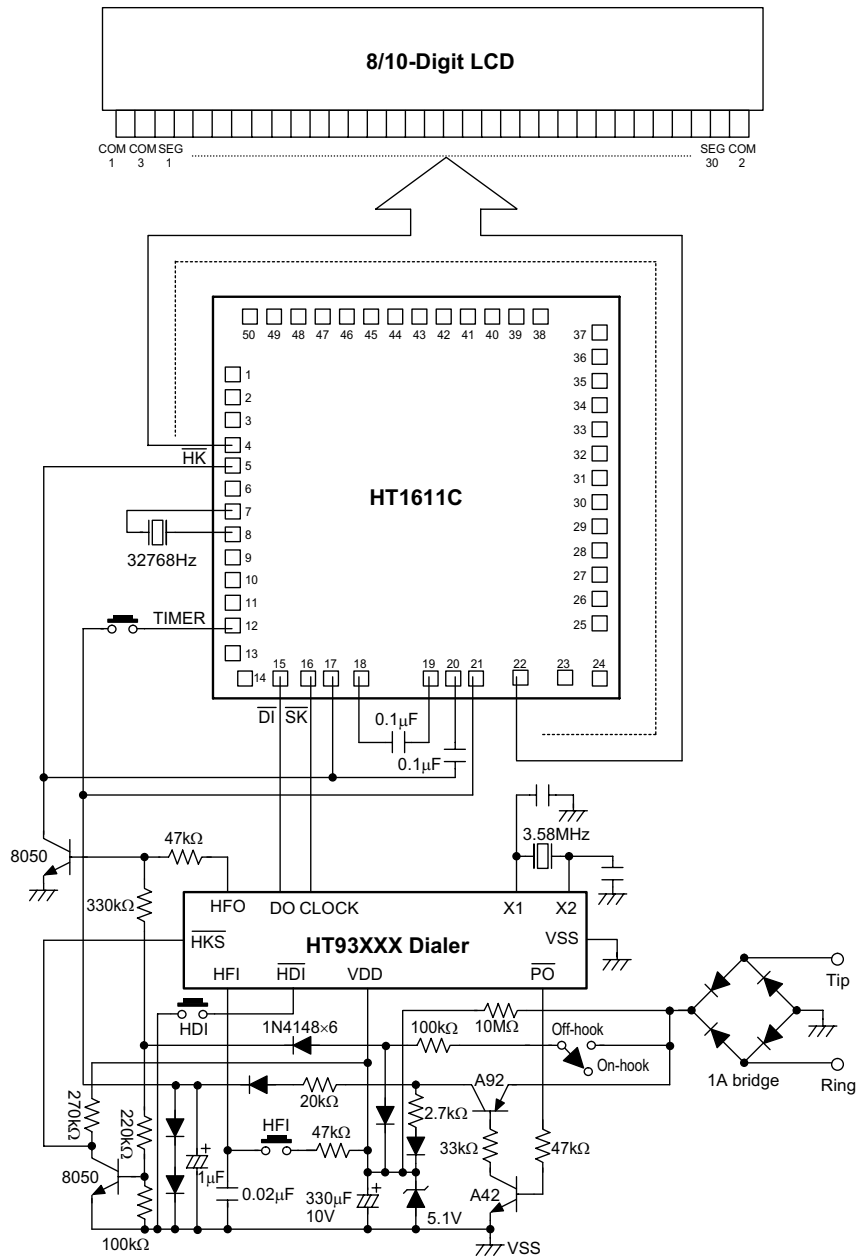

* The IC substrate should be connected to VDD in the PCB layout artwork.

For instrument or μ C use

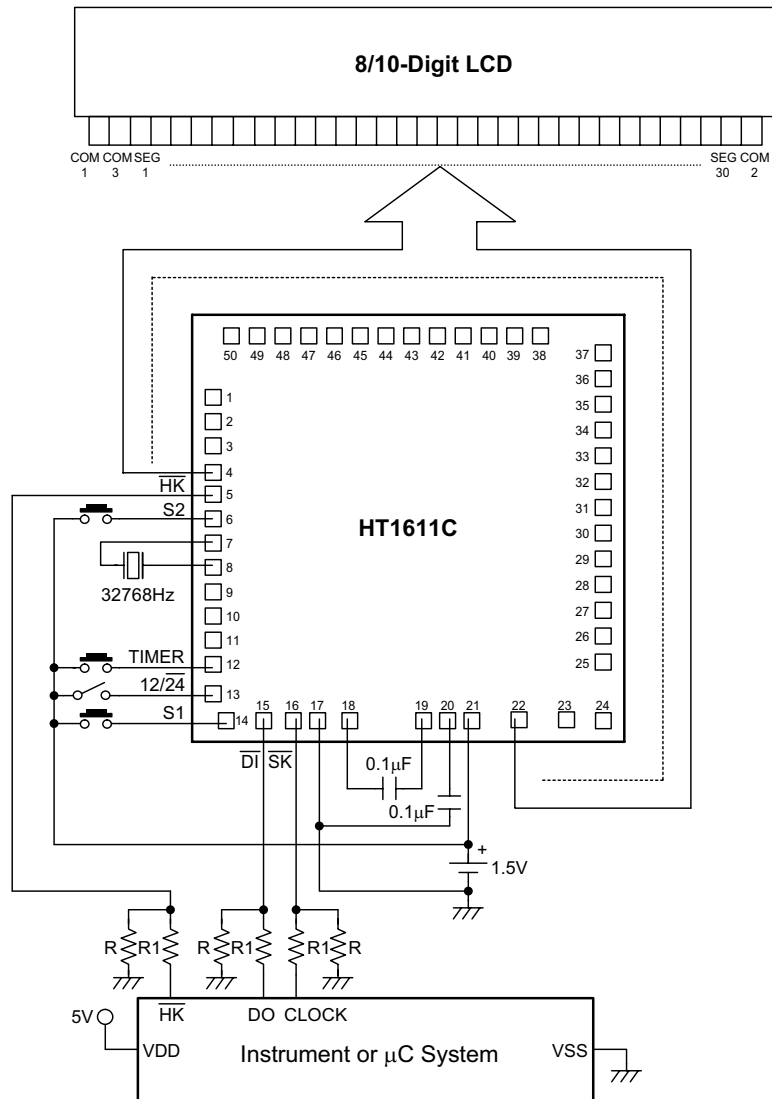

* The IC substrate should be connected to VDD in the PCB layout artwork.

Note: To drive \overline{SK} , \overline{DI} , \overline{HK} , an open drain NMOS output structure is recommended.

To drive \overline{SK} , \overline{DI} and \overline{HK} with a CMOS output structure, a voltage divider is needed ($R=4.3k\Omega$, $R1=10k\Omega$).

LCD Configuration

For 8-digit application

- Segment electrode side

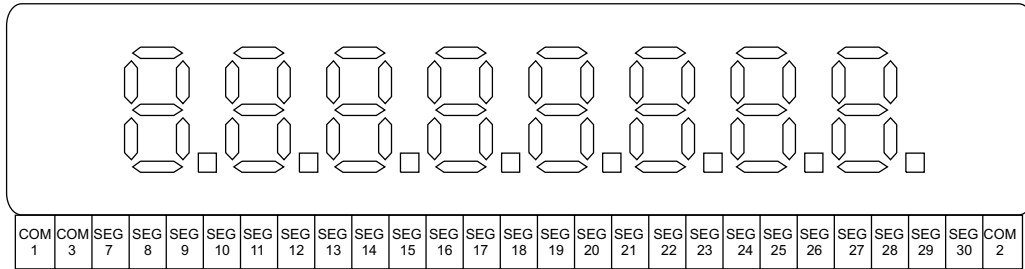

LCD driving system 1/2 bias, 1/3 duty, 3V

- Common electrode side

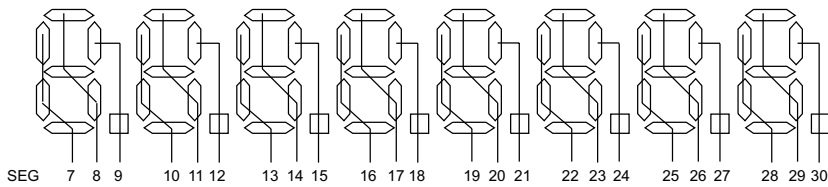

- LCD connection

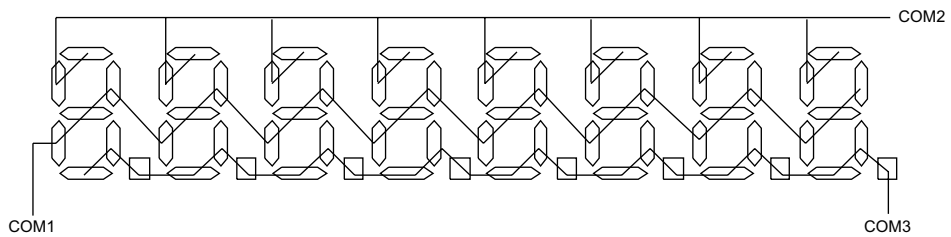

For 10-digit application

- Segment electrode side

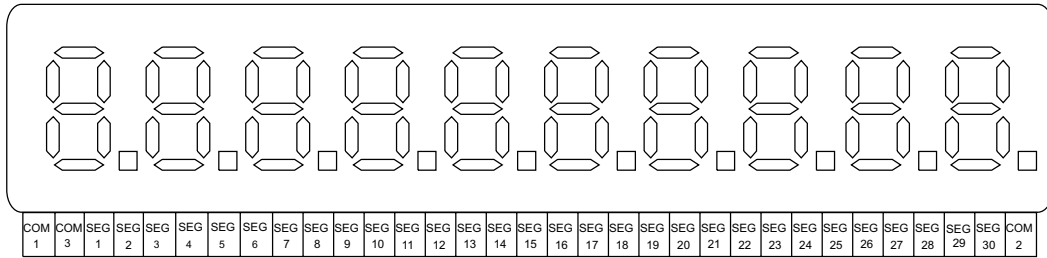

LCD driving system 1/2 bias, 1/3 duty, 3V

- Common electrode side

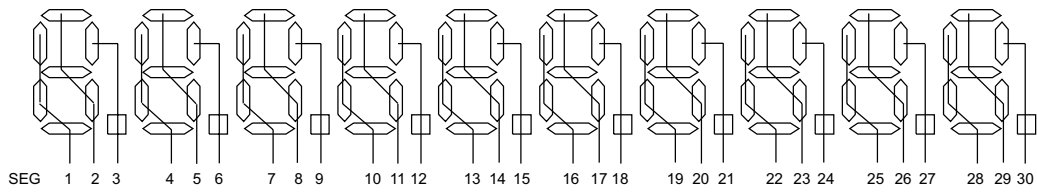

- LCD connection

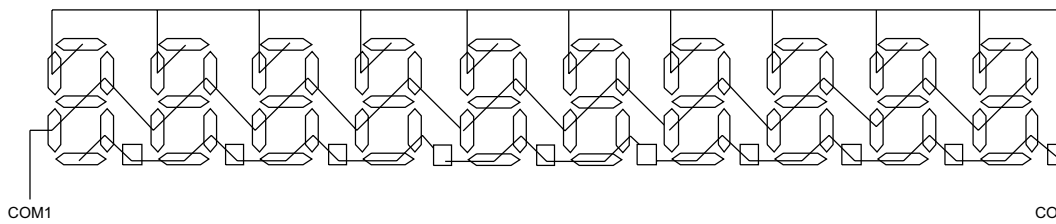

Holtek Semiconductor Inc. (Headquarters)

No.3, Creation Rd. II, Science Park, Hsinchu, Taiwan
Tel: 886-3-563-1999
Fax: 886-3-563-1189
<http://www.holtek.com.tw>

Holtek Semiconductor Inc. (Taipei Sales Office)

4F-2, No. 3-2, YuanQu St., Nankang Software Park, Taipei 115, Taiwan
Tel: 886-2-2655-7070
Fax: 886-2-2655-7373
Fax: 886-2-2655-7383 (International sales hotline)

Holtek Semiconductor Inc. (Shanghai Sales Office)

7th Floor, Building 2, No.889, Yi Shan Rd., Shanghai, China 200233
Tel: 021-6485-5560
Fax: 021-6485-0313
<http://www.holtek.com.cn>

Holtek Semiconductor Inc. (Shenzhen Sales Office)

5/F, Unit A, Productivity Building, Cross of Science M 3rd Road and Gaoxin M 2nd Road, Science Park, Nanshan District, Shenzhen, China 518057
Tel: 0755-8616-9908, 8616-9308
Fax: 0755-8616-9533

Holtek Semiconductor Inc. (Beijing Sales Office)

Suite 1721, Jinyu Tower, A129 West Xuan Wu Men Street, Xicheng District, Beijing, China 100031
Tel: 010-6641-0030, 6641-7751, 6641-7752
Fax: 010-6641-0125

Holtek Semiconductor Inc. (Chengdu Sales Office)

709, Building 3, Champagne Plaza, No.97 Dongda Street, Chengdu, Sichuan, China 610016
Tel: 028-6653-6590
Fax: 028-6653-6591

Holmate Semiconductor, Inc. (North America Sales Office)

46729 Fremont Blvd., Fremont, CA 94538
Tel: 510-252-9880
Fax: 510-252-9885
<http://www.holmate.com>

Copyright © 2001 by HOLTEK SEMICONDUCTOR INC.

The information appearing in this Data Sheet is believed to be accurate at the time of publication. However, Holtek assumes no responsibility arising from the use of the specifications described. The applications mentioned herein are used solely for the purpose of illustration and Holtek makes no warranty or representation that such applications will be suitable without further modification, nor recommends the use of its products for application that may present a risk to human life due to malfunction or otherwise. Holtek's products are not authorized for use as critical components in life support devices or systems. Holtek reserves the right to alter its products without prior notification. For the most up-to-date information, please visit our web site at <http://www.holtek.com.tw>.