Pigtailed PIN Photodiodes

Technical Data

Features

- **Variety of Flange/Pinout Options**
- **Fiber Pigtail Options**
- **Compact Package**
- **High Reliability Planar InGaAs PIN Photodiode**
- **High Responsivity**

Applications

- **Instrumentation**
- **O-E Converters**
- **Single and Multimode Fiber Communications Systems**
- **Data Communications Receivers**
- **FDDI**

Description

The PDT range of products includes a variety of compact fiber pigtailed devices designed for wide operating temperature, low cost applications such as fiber in the loop. The planar InGaAs photodiodes are manufactured using MOVPE growth technology and give low leakage and high responsivity performance with excellent reliability.

The construction of the devices includes a hermetically sealed photodiode and an actively aligned fiber pigtail and is designed to be compatible with the environmental requirements of the Bellcore TA-TSY-000983 document.

PDT1X4X

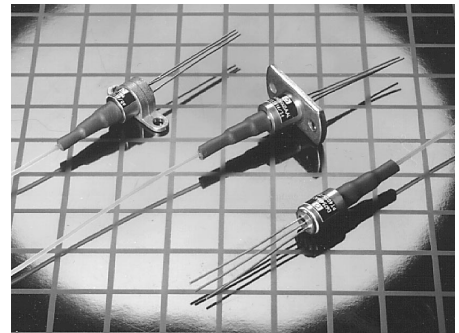

The product range includes a variety of pinout, fiber type and package mounting bracket options, designed to match the majority of offerings in the marketplace. If the specific arrangement or performance you require is not listed, please contact Hewlett-Packard. Highly flexible design and manufacturing processes allow both physical and electro-optic customization to suit your needs.

PDT Pigtailed Photodiode Specifications

Absolute Maximum Ratings

Absolute maximum limits mean that no catastrophic damage will occur if the product is subjected to these ratings for short periods, provided each limiting parameter is in isolation and all other parameters have values within the performance specification. It should not be assumed that limiting values of more than one parameter can be applied to the product at the same time.

Parameter	Symbol	Minimum	Maximum	Units
Reverse Voltage	V_R	-	20	V
Reverse Current	I_R	-	1	mA
Forward Voltage	V_f	-	1	V
Forward Current	I_f	-	5	mA
Power Dissipation	-	-	50	mW
Operating Temperature	T_c	-40	85	°C
Storage Temperature	T_s	-40	85	°C
Soldering - 10 seconds	-	-	260	°C
Fiber Pull	-	-	10	N

Performance Specification

Parameter	Symbol	Test Conditions: Unless Otherwise Stated $V_R = 5\text{ V}, T_c = 25^\circ\text{C}$	PDT134X		PDT144X		Units
			Min.	Max.	Min.	Max.	
Dark Current	I_d	$T_c = 85^\circ\text{C}$	-	1	-	1	nA
			-	50	-	50	nA
Reverse Breakdown Voltage	V_{br}	$I_R = 10\ \mu\text{A}$	35	-	35	-	V
Capacitance	C	1 Mhz	-	1.1	-	1.7	pF
Responsivity	R	$\lambda = 1300\text{ nm}$	0.7	-	0.7	-	A/W
Operating Wavelength	λ	80% points	1200	1650	1200	1650	nM
Small Signal Bandwidth	B_w		3	-	1.5	-	GHz
Rise/Fall Times	τ_r/τ_f		-	0.25	-	0.5	nS

Fiber Pigtail: Tight jacketed, self-mode stripping, multimode fiber

Parameter	Minimum	Maximum	Units
Length	1.0	-	m
Core Diameter	47	53	μm
Cladding Diameter	122	128	μm
Concentricity Error	-	8	%
Secondary Jacket Diameter	0.8	1.0	mm

PDT Mechanical Outline Options
PDT1X4X-A

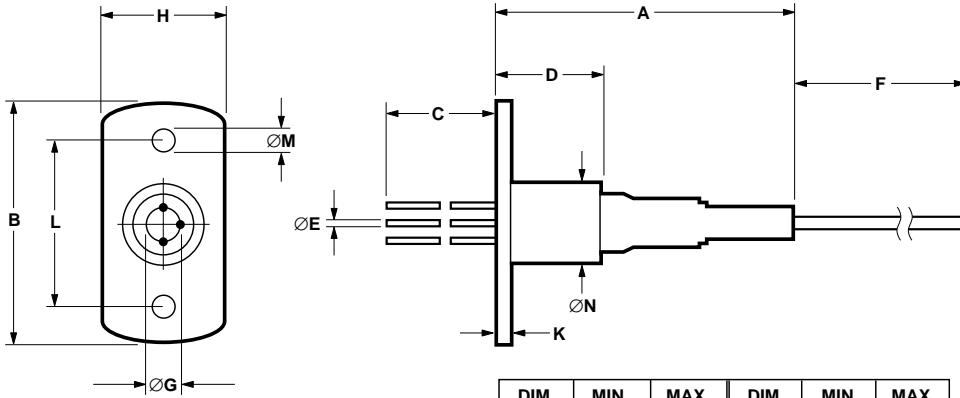

DIM.	MIN.	MAX.	DIM.	MIN.	MAX.
A	-	25.0	ØG	2.54 NOM.	
B	-	19.5	H	-	9.5
C	12.0	-	J	-	2.4
D	-	9.5	K	-	2.0
E	0.41	0.47	L	13.35	13.55
F	1000	-	ØM	2.1	2.4
			ØN	-	6.25

ALL DIMENSIONS IN MILLIMETERS

PDT1X4X-B

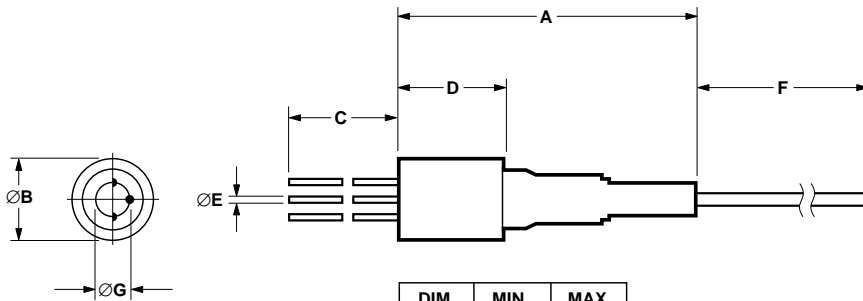

DIM.	MIN.	MAX.
A	-	25.0
ØB	-	6.25
C	12.0	-
D	-	8.5
ØE	0.41	0.47
F	1000	-
ØG	2.54 NOM.	

ALL DIMENSIONS IN MILLIMETERS

PDT Mechanical Outline Options PDT1X4X-D

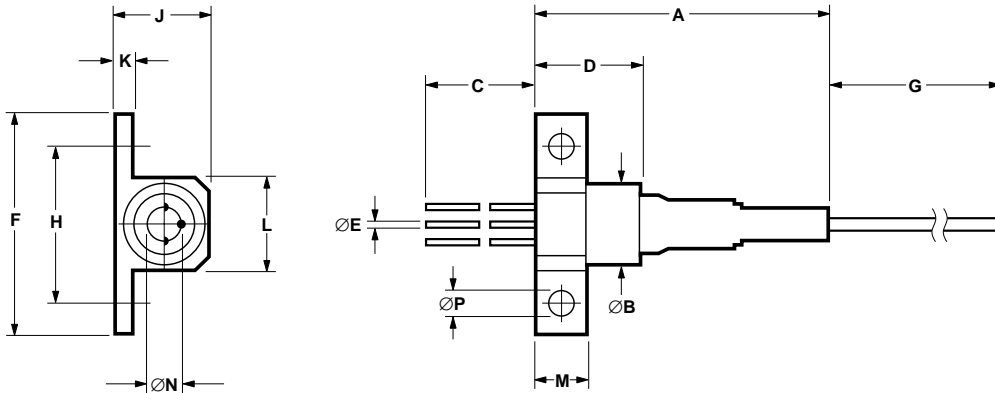

DIM.	MIN.	MAX.	DIM.	MIN.	MAX.
A	-	25.0	H	12.7 NOM.	
ØB	-	6.25	J	-	7.5
C	12.0	-	K	0.9	1.1
D	-	9.5	L	-	7.5
ØE	0.41	0.47	M	3.8	4.2
G	1000	-	ØN	2.54 NOM.	
			ØP	2.1	2.4

ALL DIMENSIONS IN MILLIMETERS

PDT Electrical Pin-Outs

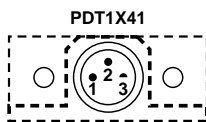

PIN 1: CATHODE + ve
PIN 2: ANODE - ve
PIN 3: CASE

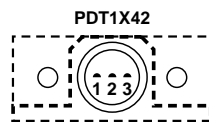
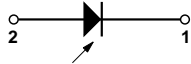

PIN 1: ANODE - ve
PIN 2: CATHODE + ve
PIN 3: CASE

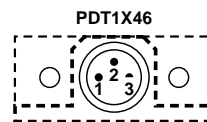
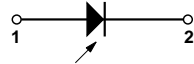

PIN 1: CATHODE + ve
PIN 2: CASE
PIN 3: ANODE - ve

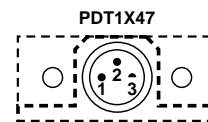
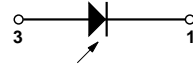

PIN 1: ANODE - ve
PIN 2: CATHODE + ve
PIN 3: CASE

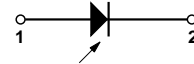

Ordering Information

PDT1 X 4 X-X X-X X

Connector Type:

FP = FC/PC

ST = ST®

BI = Biconic

SC = SC

DN = DIN

D4 = D4

SF = Super Polish FC/PC

TO to Mount Connection:

I = Isolated (Default if not specified)

S = Shorted

Flange Type:

A = 2 hole panel mount, 13.4 mm between centers

B = Barrel

D = 2 hole PCB mount, 12.7 mm between centers

G = 2 hole PCB mount, 14.0 mm between centers

Pin Out:

Options shown on Page 4

Device Type:

3 = 50 μ m Photodiode

4 = 90 μ m Photodiode

Fiber Type:

1 = 50/125 Fiber

Options available for single mode and 62.5/125 fibers

Preferred Options:

PDT1346-DI

PDT1441-DI

PDT1442-AS

PDT1442-BI

PDT1442-DI

PDT1446-DI

Additional options are available to meet your specific needs. Please contact your local representative for details.