

---

# Low Cost, Miniature Fiber Optic Components with ST®, SMA, SC and FC Ports

## Technical Data

### Features

- Meets IEEE 802.3 Ethernet and 802.5 Token Ring Standards
- Low Cost Transmitters and Receivers
- Choice of ST®, SMA, SC or FC Ports
- 820 nm Wavelength Technology
- Signal Rates up to 175 Megabaud
- Link Distances up to 4 km
- Specified with 50/125  $\mu\text{m}$ , 62.5/125  $\mu\text{m}$ , 100/140  $\mu\text{m}$ , and 200  $\mu\text{m}$  HCS® Fiber
- Repeatable ST Connections within 0.2 dB Typical
- Unique Optical Port Design for Efficient Coupling
- Auto-Insertable and Wave Solderable
- No Board Mounting Hardware Required
- Wide Operating Temperature Range -40°C to 85°C
- AlGaAs Emitters 100% Burn-In Ensures High Reliability
- Conductive Port Option with the SMA and ST Threaded Port Styles

### Applications

- Local Area Networks
- Computer to Peripheral Links
- Computer Monitor Links
- Digital Cross Connect Links
- Central Office Switch/PBX Links
- Video Links
- Modems and Multiplexers
- Suitable for Tempest Systems
- Industrial Control Links

### Description

The HFBR-0400 Series of components is designed to provide cost effective, high performance fiber optic communication links for information systems and industrial applications with link distances of up to 4 kilometers. With the HFBR-24X6, the 125 MHz analog receiver, data rates of up to 175 megabaud are attainable.

---

### HFBR-0400 Series

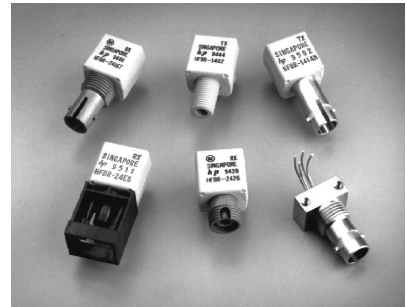

Transmitters and receivers are directly compatible with popular "industry-standard" connectors: ST, SMA, SC and FC. They are completely specified with multiple fiber sizes; including 50/125  $\mu\text{m}$ , 62.5/125  $\mu\text{m}$ , 100/140  $\mu\text{m}$ , and 200  $\mu\text{m}$ .

Complete evaluation kits are available for ST and SMA product offerings; including transmitter, receiver, connected cable, and technical literature. In addition, ST and SMA connected cables are available for evaluation.

ST® is a registered trademark of AT&T.  
HCS® is a registered trademark of the SpecTran Corporation.

## HFBR-0400 Series Part Number Guide

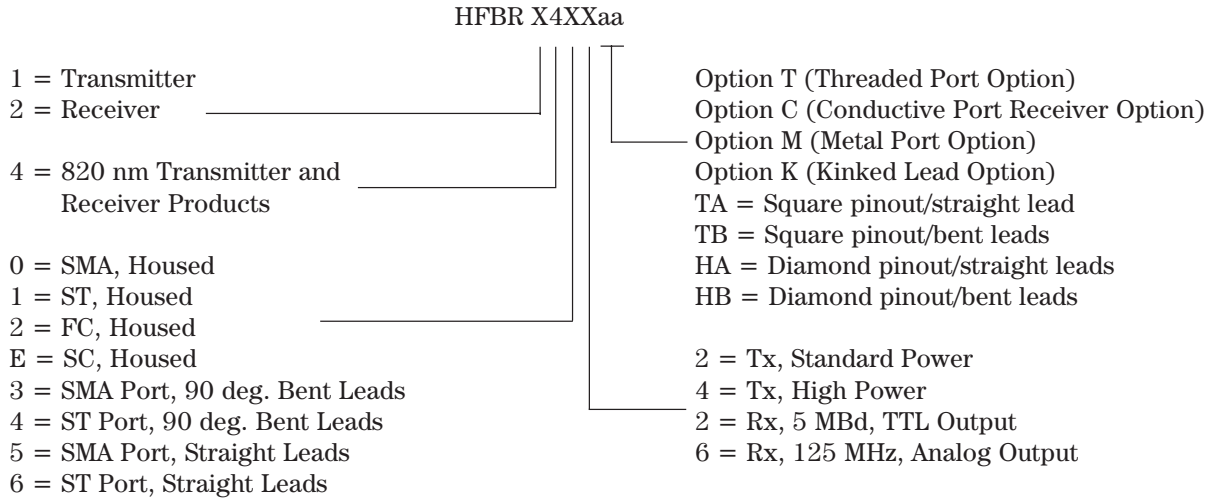

## LINK SELECTION GUIDE

Data Rate (MBd)	Distance (m)	Transmitter	Receiver	Fiber Size (µm)	Evaluation Kit
5	1500	HFBR-14X2	HFBR-24X2	200 HCS	N/A
5	2000	HFBR-14X4	HFBR-24X2	62.5/125	HFBR-04X0
20	2700	HFBR-14X4	HFBR-24X6	62.5/125	HFBR-0414, HFBR-0463
32	2200	HFBR-14X4	HFBR-24X6	62.5/125	HFBR-0414
55	1400	HFBR-14X4	HFBR-24X6	62.5/125	HFBR-0414
125	700	HFBR-14X4	HFBR-24X6	62.5/125	HFBR-0416
155	600	HFBR-14X4	HFBR-24X6	62.5/125	HFBR-0416
175	500	HFBR-14X4	HFBR-24X6	62.5/125	HFBR-0416

For additional information on specific links see the following individual link descriptions. Distances measured over temperature range from 0 to 70°C.

### Applications Support Guide

This section gives the designer information necessary to use the HFBR-0400 series components to

make a functional fiber-optic transceiver. HP offers a wide selection of evaluation kits for hands-on experience with fiber-optic products as well as a wide

range of application notes complete with circuit diagrams and board layouts. Furthermore, HP's application support group is always ready to assist with any design consideration.

### Application Literature

Title	Description
HFBR-0400 Series Reliability Data	Transmitter & Receiver Reliability Data
Application Bulletin 73	Low Cost Fiber Optic Transmitter & Receiver Interface Circuits
Application Bulletin 78	Low Cost Fiber Optic Links for Digital Applications up to 155 MBd
Application Note 1038	Complete Fiber Solutions for IEEE 802.3 FOIRL, 10Base-FB and 10 Base-FL
Application Note 1065	Complete Solutions for IEEE 802.5J Fiber-Optic Token Ring
Application Note 1073	HFBR-0319 Test Fixture for 1X9 Fiber Optic Transceivers
Application Note 1086	Optical Fiber Interconnections in Telecommunication Products

## **HFBR-0400 Series Evaluation Kits**

### **HFBR-0410 ST Evaluation Kit**

Contains the following :

- One HFBR-1412 transmitter
- One HFBR-2412 five megabaud TTL receiver
- Three meters of ST connected 62.5/125 (µm fiber optic cable with low cost plastic ferrules.
- Related literature

### **HFBR-0414 ST Evaluation Kit**

Includes additional components to interface to the transmitter and receiver as well as the PCB to reduce design time.

Contains the following:

- One HFBR-1414T transmitter
- One HFBR-2416T receiver
- Three meters of ST connected 62.5/125 µm fiber optic cable
- Printed circuit board
- ML-4622 CP Data Quantizer
- 74ACT11000N LED Driver
- LT1016CN8 Comparator
- 4.7 µH Inductor
- Related literature

### **HFBR-0400 SMA Evaluation Kit**

Contains the following :

- One HFBR-1402 transmitter
- One HFBR-2402 five megabaud TTL receiver
- Two meters of SMA connected 1000 µm plastic optical fiber
- Related literature

### **HFBR-0416 Evaluation Kit**

Contains the following:

- One fully assembled 1x9 transceiver board for 155 MBd evaluation including:
  - HFBR-1414 transmitter
  - HFBR-2416 receiver
  - circuitry
- Related literature

### **HFBR-0463 Ethernet MAU Evaluation Kit**

Contains the following:

- One fully assembled Media Attachment Unit (MAU) board which includes:
  - HFBR-1414 transmitter
  - HFBR-2416 receiver
  - HFBR-4663 IC
- Related literature

Note: Cable not included. Order HFBR-BXS010 separately (2 pieces)

## **Package and Handling Information**

### **Package Information**

All HFBR-0400 Series transmitters and receivers are housed in a low-cost, dual-inline package that is made of high strength, heat resistant, chemically resistant, and UL 94V-0 flame retardant ULTEM® (plastic (UL File #E121562)). The transmitters are easily identified by the light grey color connector port. The receivers are easily identified by the dark grey color connector port. (Black color for conductive port.) The package is designed for auto-insertion and wave soldering so it is ideal for

high volume production applications.

### **Handling and Design Information**

Each part comes with a protective port cap or plug covering the optics. These caps/plugs will vary by port style. When soldering, it is advisable to leave the protective cap on the unit to keep the optics clean. Good system performance requires clean port optics and cable ferrules to avoid obstructing the optical path. Clean compressed air often is sufficient to remove particles of dirt; methanol on a cotton swab also works well.

### **Recommended Chemicals for Cleaning/Degreasing HFBR-0400 Products**

Alcohols: methyl, isopropyl, isobutyl. Aliphatics: hexane, heptane, Other: soap solution, naphtha.

Do not use partially halogenated hydrocarbons such as 1,1,1 trichloroethane, ketones such as MEK, acetone, chloroform, ethyl acetate, methylene dichloride, phenol, methylene chloride, or N-methylpyrrolidone. Also, HP does not recommend the use of cleaners that use halogenated hydrocarbons because of their potential environmental harm.

**Mechanical Dimensions  
HFBR-0400 SMA Series  
HFBR-X40X**

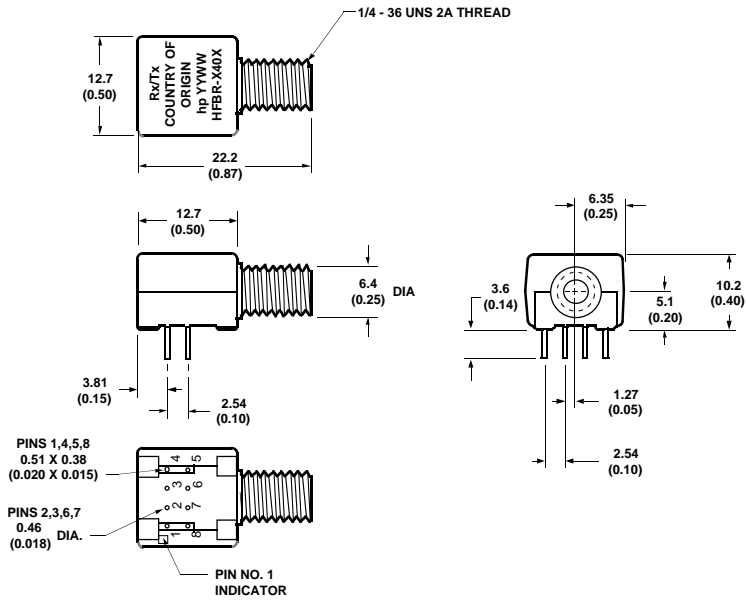

**HFBR-X43X**

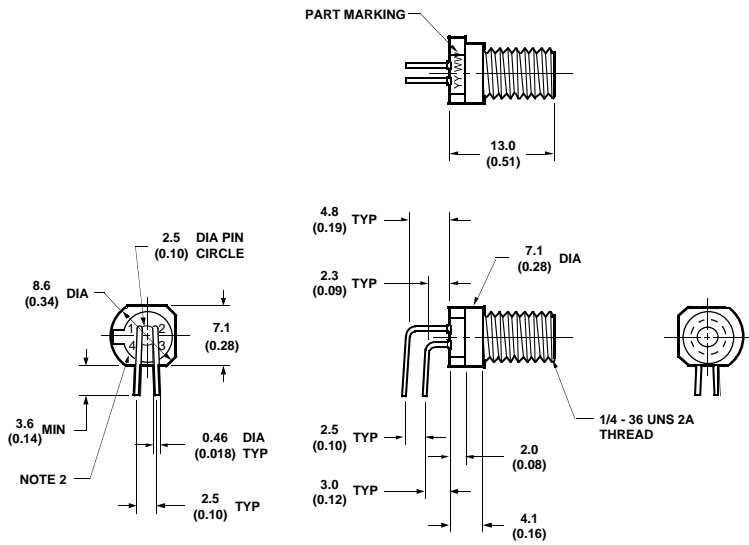

**HFBR-X45X**

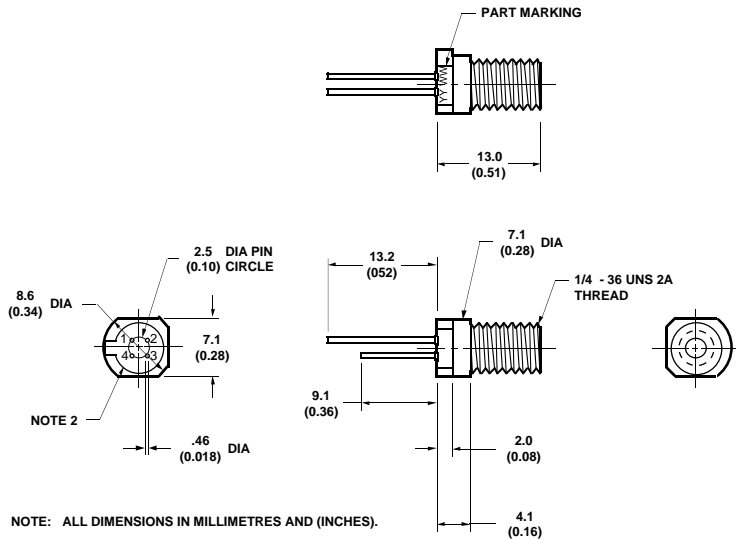

NOTE: ALL DIMENSIONS IN MILLIMETRES AND (INCHES).

**Mechanical Dimensions**  
**HFBR-0400 ST Series**  
**HFBR-X41X**

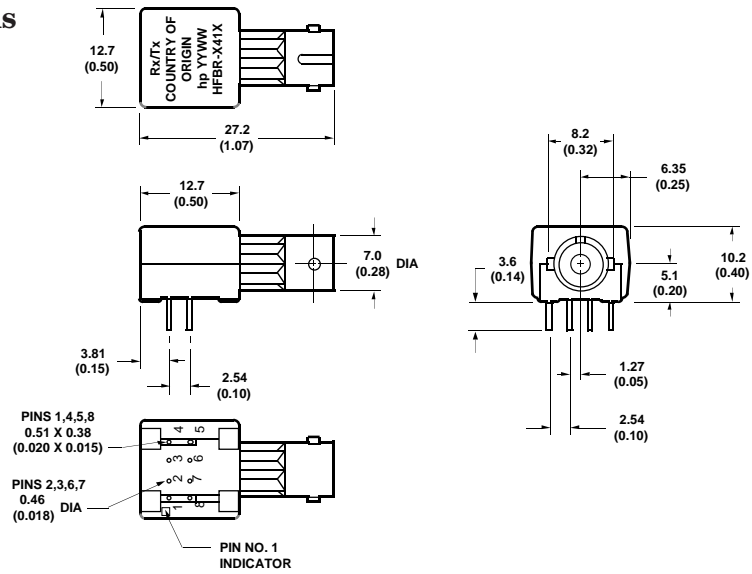

**HFBR-X44X**

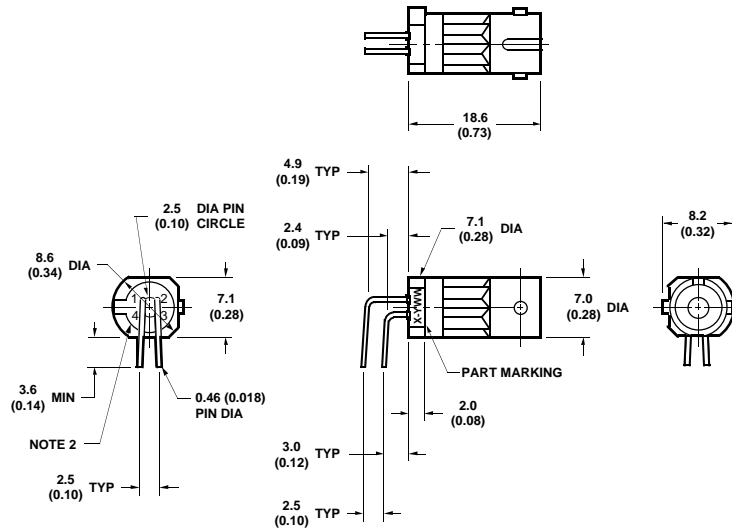

**HFBR-X46X**

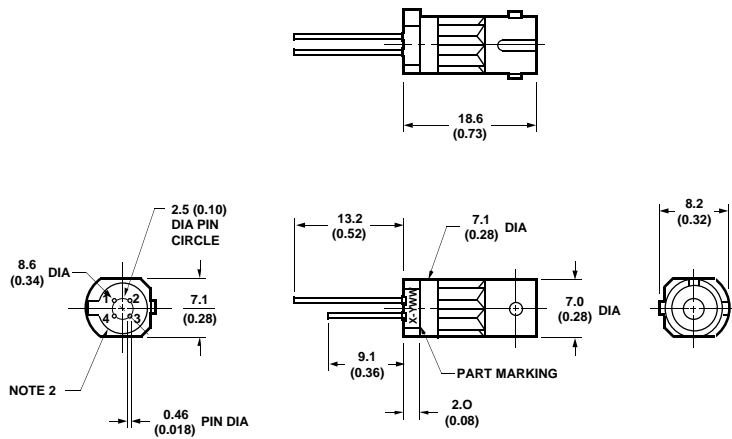

NOTE: ALL DIMENSIONS IN MILLIMETRES AND (INCHES).

# Mechanical Dimensions HFBR-0400T Threaded ST Series

## HFBR-X41XT

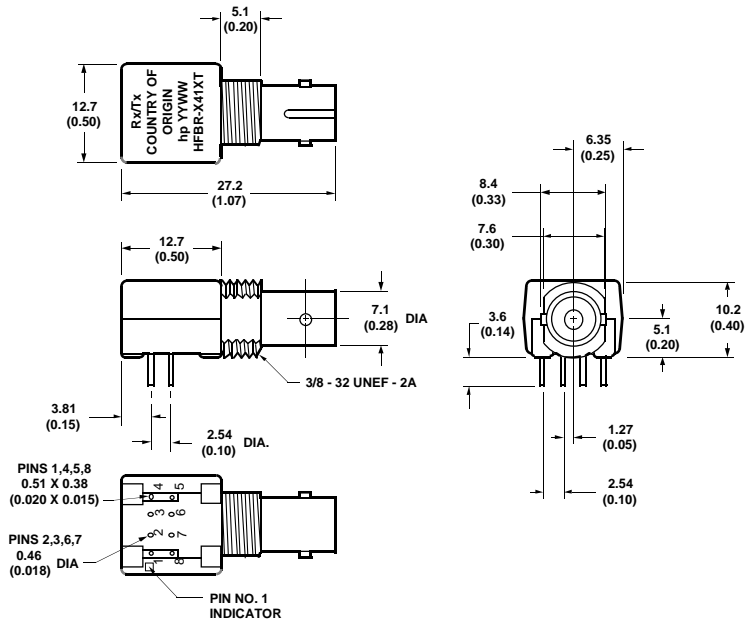

## HFBR-X44XT

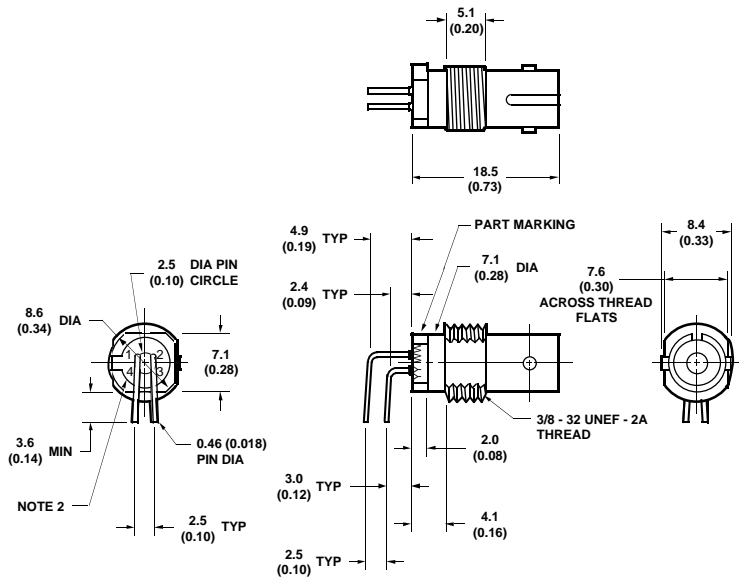

## HFBR-X46XT

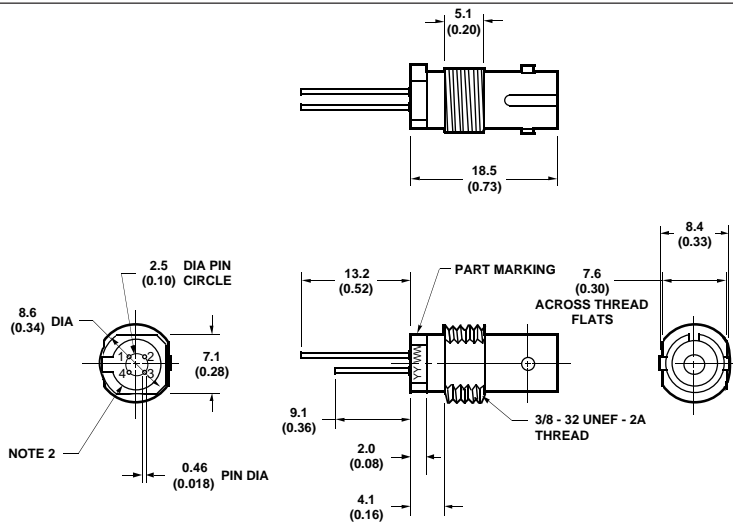

## Mechanical Dimensions HFBR-0400 FC Series

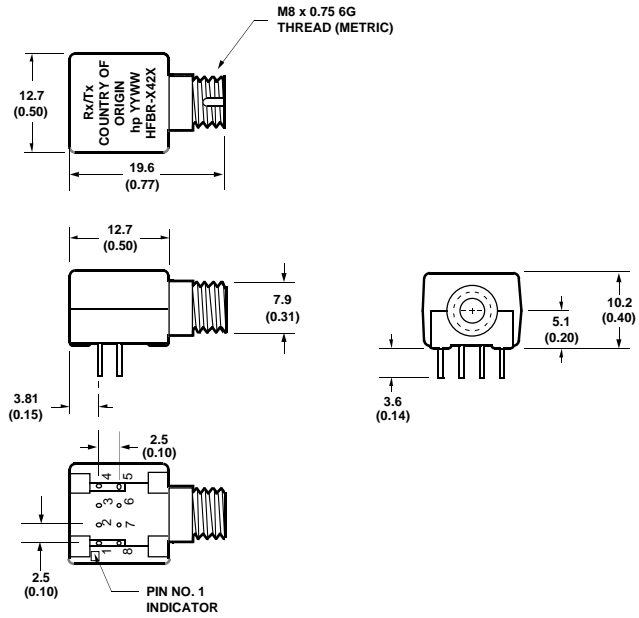

## Mechanical Dimensions HFBR-0400 SC Series

HFBR-X4EX

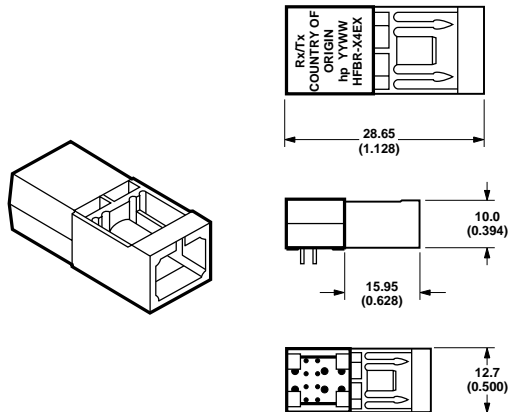

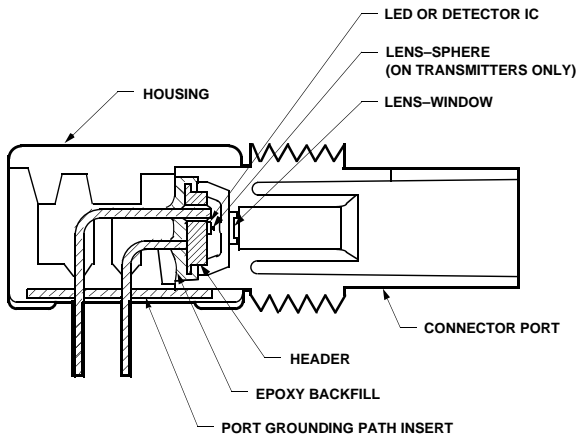
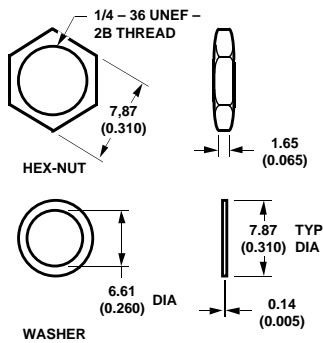

Figure 1. HFBR-0400 ST Series Cross-Sectional View.

## Panel Mount Hardware

### HFBR-4401: for SMA Ports



### HFBR-4411: for ST Ports

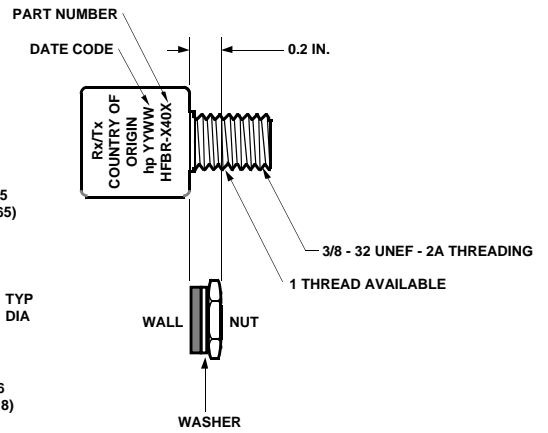
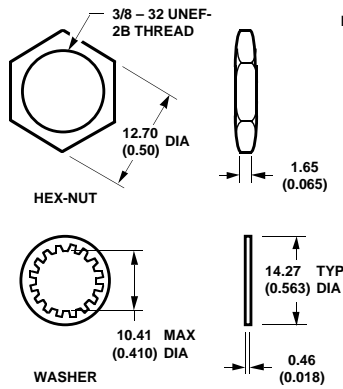

(Each HFBR-4401 and HFBR-4411 kit consists of 100 nuts and 100 washers.)

## Port Cap Hardware

- HFBR-4402: 500 SMA Port Caps
- HFBR-4120: 500 ST Port Plugs (120 psi)
- HFBR-4412: 500 FC Port Caps
- HFBR-4417: 500 SC Port Plugs



## Options

In addition to the various port styles available for the HFBR-0400 series products, there are also several extra options that can be ordered. To order an option, simply place the corresponding option number at the end of the part number. For instance, a metal-port option SMA receiver would be HFBR-2406M. You can add any number of options in series at the end of a part number. Please contact your local sales office for further information or browse HP's fiber optics home page at <http://www.hp.com/go/fiber>

### Option T (Threaded Port Option)

- Allows ST style port components to be panel mounted.
- Compatible with all current makes of ST multimode connectors
- Mechanical dimensions are compliant with MIL-STD-83522/13
- Maximum wall thickness when using nuts and washers from the HFBR-4411 hardware kit is 2.8 mm (0.11 inch)
- Available on all ST ports

### Option C (Conductive Port Receiver Option)

- Designed to withstand electrostatic discharge (ESD) of 25kV to the port
- Significantly reduces effect of electromagnetic interference (EMI) on receiver sensitivity

- Allows designer to separate the signal and conductive port grounds
- Recommended for use in noisy environments
- Available on SMA and threaded ST port style receivers only

### Option M (Metal Port Option)

- Nickel plated aluminum connector receptacle
- Designed to withstand electrostatic discharge (ESD) of 15kV to the port
- Significantly reduces effect of electromagnetic interference (EMI) on receiver sensitivity
- Allows designer to separate the signal and metal port grounds
- Recommended for use in very noisy environments
- Available on SMA, FC, ST, and threaded ST ports

### Option K (Kinked Lead Option)

- Grounded outside 4 leads are "kinked"
- Allows components to stay anchored in the PCB during wave solder and aqueous wash processes

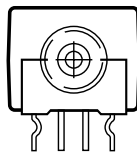

### Options TA, TB, HA, HB (Active Device Mount Options)

*(These options are unrelated to the threaded port option T.)*

- All metal, panel mountable package with a 3 or 4 pin receptacle end
- Available for HFBR-14X4, 24X2 and 24X6 components
- Choose from diamond or square pinout, straight or bent leads ADM Picture

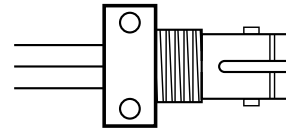

- TA = Square pinout/straight leads
- TB = Square pinout/bent leads
- HA = Diamond pinout/straight leads
- HB = Diamond pinout/bent leads

### Duplex Option

In addition to the standard options, some HFBR-0400 series products come in a duplex configuration with the transmitter on the left and the receiver on the right. This option was designed for ergonomic and efficient manufacturing. The following part numbers are available in the duplex option:

- HFBR-5414 (Duplex ST)
- HFBR-5414T (Duplex Threaded ST)
- HFBR-54E4 (Duplex SC)

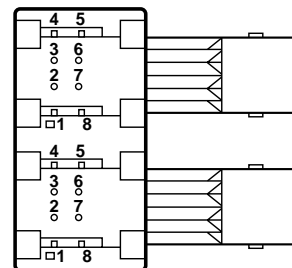

# Typical Link Data

## HFBR-0400 Series

### Description

The following technical data is taken from 4 popular links using the HFBR-0400 series: the 5 MBd link, Ethernet 20 MBd link, Token Ring 32 MBd link, and the 155 MBd link. The data given

corresponds to transceiver solutions combining the HFBR-0400 series components and various recommended transceiver design circuits using off-the-shelf electrical components. This data is meant to be regarded as an

example of typical link performance for a given design and does not call out any link limitations. Please refer to the appropriate application note given for each link to obtain more information.

### 5 MBd Link (HFBR-14XX/24X2)

Link Performance -40°C to +85°C unless otherwise specified

Parameter	Symbol	Min.	Typ.	Max.	Units	Conditions	Reference
Optical Power Budget with 50/125 $\mu\text{m}$ fiber	OPB <sub>50</sub>	4.2	9.6		dB	HFBR-14X4/24X2 NA = 0.2	Note 1
Optical Power Budget with 62.5/125 $\mu\text{m}$ fiber	OPB <sub>62.5</sub>	8.0	15		dB	HFBR-14X4/24X2 NA = 0.27	Note 1
Optical Power Budget with 100/140 $\mu\text{m}$ fiber	OPB <sub>100</sub>	8.0	15		dB	HFBR-14X2/24X2 NA = 0.30	Note 1
Optical Power Budget with 200 $\mu\text{m}$ fiber	OPB <sub>200</sub>	12	20		dB	HFBR-14X2/24X2 NA = 0.37	Note 1
Date Rate Synchronous		dc		5	MBd		Note 2
Asynchronous		dc		2.5	MBd		Note 3, Fig. 7
Propagation Delay LOW to HIGH	t <sub>PLH</sub>		72		ns	T <sub>A</sub> = 25°C, P <sub>R</sub> = -21 dBm Peak	Figs. 6, 7, 8
Propagation Delay HIGH to LOW	t <sub>PHL</sub>		46		ns		
System Pulse Width Distortion	t <sub>PLH</sub> -t <sub>PHL</sub>		26		ns		
Bit Error Rate	BER			10 <sup>-9</sup>		Data Rate < 5 Bd P <sub>R</sub> > -24 dBm Peak	

#### Notes:

1. OPB at T<sub>A</sub> = -40 to 85°C, V<sub>CC</sub> = 5.0 V dc, I<sub>F ON</sub> = 60 mA. P<sub>R</sub> = -24 dBm peak.
2. Synchronous data rate limit is based on these assumptions: a) 50% duty factor modulation, e.g., Manchester I or BiPhase Manchester II; b) continuous data; c) PLL Phase Lock Loop demodulation; d) TTL threshold.
3. Asynchronous data rate limit is based on these assumptions: a) NRZ data; b) arbitrary timing-no duty factor restriction; c) TTL threshold.

## 5 MBd Logic Link Design

If resistor  $R_1$  in Figure 2 is  $70.4 \Omega$ , a forward current  $I_F$  of  $48 \text{ mA}$  is applied to the HFBR-14X4 LED transmitter. With  $I_F = 48 \text{ mA}$  the HFBR-14X4/24X2 logic link is guaranteed to work with  $62.5/125 \mu\text{m}$  fiber optic cable over the entire range of  $0$  to  $1750$  meters at a data rate of dc to  $5 \text{ MBd}$ , with arbitrary data format and pulse width distortion typically less than  $25\%$ . By setting  $R_1 = 115 \Omega$ , the transmitter can be driven with  $I_F = 30 \text{ mA}$ , if it is desired to economize on power or achieve lower pulse distortion.

The following example will illustrate the technique for selecting the appropriate value of  $I_F$  and  $R_1$ .

Maximum distance required =  $400$  meters. From Figure 3 the drive current should be  $15 \text{ mA}$ . From the transmitter data  $V_F = 1.5 \text{ V (max.)}$  at  $I_F = 15 \text{ mA}$  as shown in Figure 9.

$$R_1 = \frac{V_{CC} - V_F}{I_F} = \frac{5 \text{ V} - 1.5 \text{ V}}{15 \text{ mA}}$$

$$R_1 = 233 \Omega$$

The curves in Figures 3, 4, and 5 are constructed assuming no in-line splice or any additional system loss. Should the link consist of any in-line splices, these curves can still be used to calculate link limits provided they are shifted by the additional system loss expressed in dB. For example, Figure 3 indicates that with  $48 \text{ mA}$  of transmitter drive current, a  $1.75 \text{ km}$  link distance is achievable with  $62.5/125 \mu\text{m}$  fiber which has a maximum attenuation of  $4 \text{ dB/km}$ . With  $2 \text{ dB}$  of additional system loss, a  $1.25 \text{ km}$  link distance is still achievable.

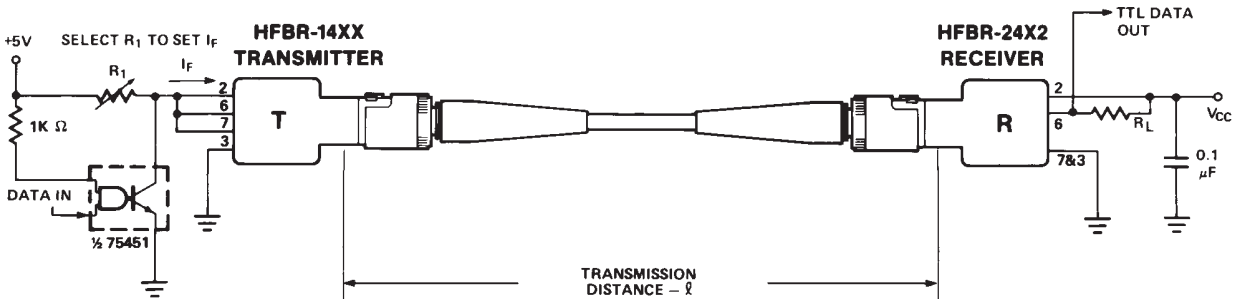

NOTE:  
IT IS ESSENTIAL THAT A BYPASS CAPACITOR ( $0.01 \mu\text{F}$  TO  $0.1 \mu\text{F}$  CERAMIC) BE CONNECTED FROM PIN 2 TO PIN 7 OF THE RECEIVER. TOTAL LEAD LENGTH BETWEEN BOTH ENDS OF THE CAPACITOR AND THE PINS SHOULD NOT EXCEED  $20 \text{ mm}$ .

Figure 2. Typical Circuit Configuration.

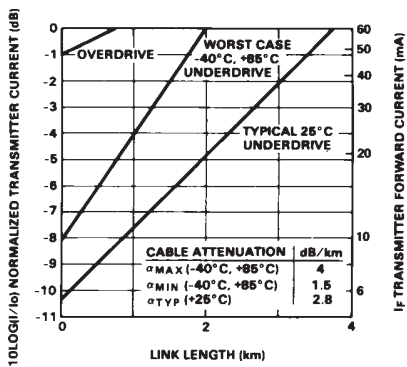

Figure 3. HFBR-1414/HFBR-2412 Link Design Limits with 62.5/125  $\mu\text{m}$  Cable.

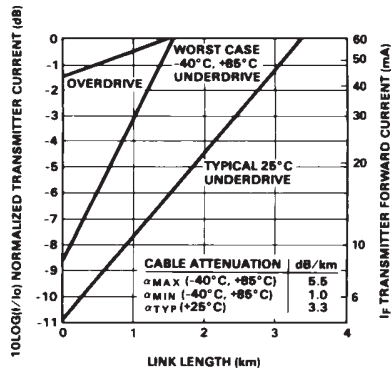

Figure 4. HFBR-14X2/HFBR-24X2 Link Design Limits with 100/140  $\mu\text{m}$  Cable.

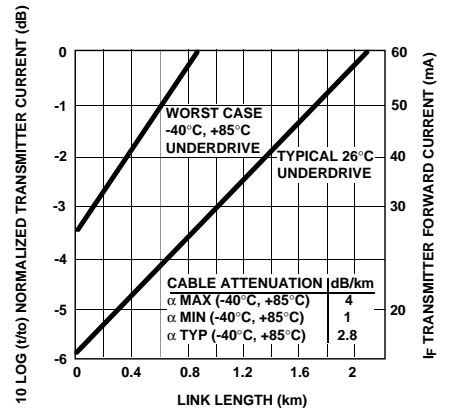

Figure 5. HFBR-14X4/HFBR-24X2 Link Design Limits with 50/125  $\mu\text{m}$  Cable.

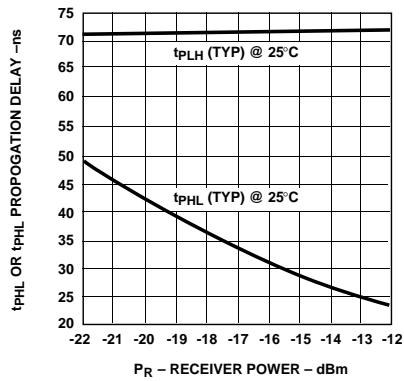

Figure 6. Propagation Delay through System with One Meter of Cable.

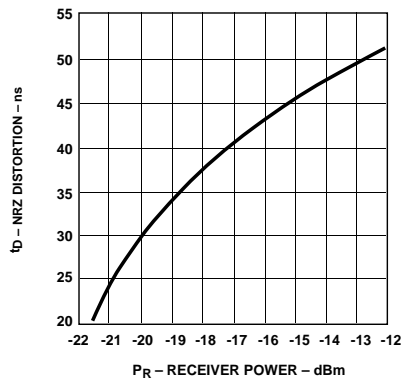

Figure 7. Typical Distortion of Pseudo Random Data at 5 Mb/s.

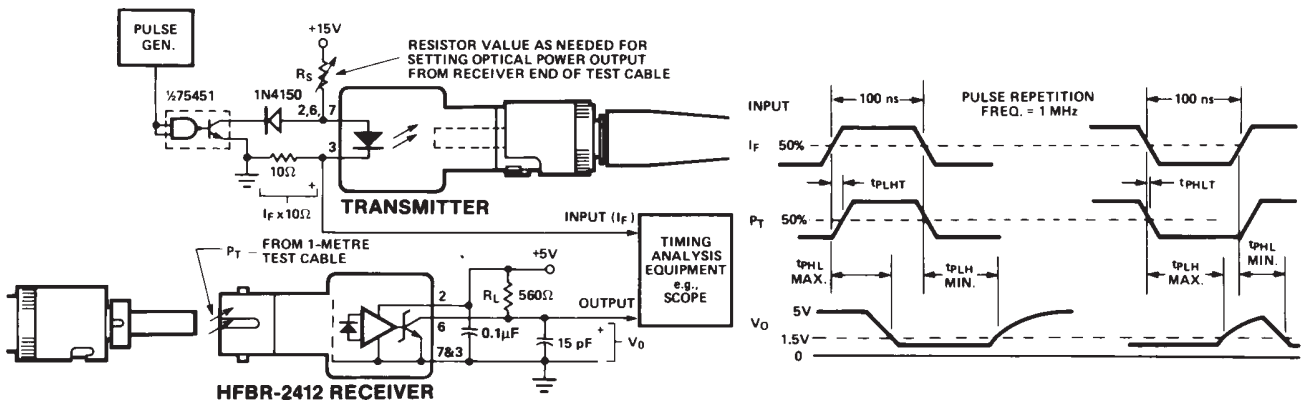

Figure 8. System Propagation Delay Test Circuit and Waveform Timing Definitions.

## Ethernet 20 MBd Link (HFBR-14X4/24X6)

(refer to Application Note 1038 for details)

### Typical Link Performance

Parameter	Symbol	Typ. <sup>[1,2]</sup>	Units	Conditions
Receiver Sensitivity		-34.4	dBm average	20 MBd D2D2 Hexadecimal Data 2 km 62.5/125 μm fiber
Link Jitter		7.56	ns pk-pk	ECL Out Receiver
		7.03	ns pk-pk	TTL Out Receiver
Transmitter Jitter		0.763	ns pk-pk	20 MBd D2D2 Hexadecimal Data
Optical Power	P <sub>T</sub>	-15.2	dBm average	20 MBd D2D2 Hexadecimal Data Peak I <sub>F,ON</sub> = 60 mA
LED rise time	t <sub>r</sub>	1.30	ns	1 MHz Square Wave Input
LED fall time	t <sub>f</sub>	3.08	ns	
Mean difference	t <sub>r</sub> - t <sub>f</sub>	1.77	ns	
Bit Error Rate	BER	10 <sup>-10</sup>		
Output Eye Opening		36.7	ns	At AUI Receiver Output
Data Format 50% Duty Factor		20	MBd	

#### Notes:

1. Typical data at T<sub>A</sub> = 25°C, V<sub>CC</sub> = 5.0 V dc.
2. Typical performance of circuits shown in Figure 1 and Figure 3 of AN-1038 (see applications support section).

## Token Ring 32 MBd Link (HFBR-14X4/24X6)

(refer to Application Note 1065 for details)

### Typical Link Performance

Parameter	Symbol	Typ. <sup>[1,2]</sup>	Units	Conditions
Receiver Sensitivity		-34.1	dBm average	32 MBd D2D2 Hexadecimal Data 2 km 62.5/125 μm fiber
Link Jitter		6.91	ns pk-pk	ECL Out Receiver
		5.52	ns pk-pk	TTL Out Receiver
Transmitter Jitter		0.823	ns pk-pk	32 MBd D2D2 Hexadecimal Data
Optical Power Logic Level "0"	P <sub>T ON</sub>	-12.2	dBm peak	Transmitter TTL in I <sub>F ON</sub> = 60 mA, I <sub>F OFF</sub> = 1 mA
Optical Power Logic Level "1"	P <sub>T OFF</sub>	-82.2		
LED Rise Time	t <sub>r</sub>	1.3	nsec	1 MHz Square Wave Input
LED Fall Time	t <sub>f</sub>	3.08	nsec	
Mean Difference	t <sub>r</sub> - t <sub>f</sub>	1.77	nsec	
Bit Error Rate	BER	10 <sup>-10</sup>		
Data Format 50% Duty Factor		32	MBd	

#### Notes:

1. Typical data at T<sub>A</sub> = 25°C, V<sub>CC</sub> = 5.0 V dc.
2. Typical performance of circuits shown in Figure 1 and Figure 3 of AN-1065 (see applications support section)

## 155 MBd Link (HFBR-14X4/24X6)

(refer to Application Bulletin 78 for details)

### Typical Link Performance

Parameter	Symbol	Typ. <sup>[1,2]</sup>	Units	Max.	Units	Conditions	Ref.
Optical Power Budget with 50/125 $\mu\text{m}$ fiber	OPB <sub>50</sub>	7.9	13.9		dB	NA = 0.2	Note 2
Optical Power Budget with 62.5/125 $\mu\text{m}$ fiber	OPB <sub>62</sub>	11.7	17.7		dB	NA = 0.27	
Optical Power Budget with 100/140 $\mu\text{m}$ fiber	OPB <sub>100</sub>	11.7	17.7		dB	NA = 0.30	
Optical Power Budget with 200 $\mu\text{m}$ HCSFiber	OPB <sub>200</sub>	16.0	22.0		dB	NA = 0.35	
Data Format 20% to 80% Duty Factor		1		175	MBd		
System Pulse Width Distortion	$ t_{\text{PLH}} - t_{\text{PHL}} $		1		ns	PR = -7 dBm Peak 1 meter 62.5/125 $\mu\text{m}$ fiber	
Bit Error Rate	BER		$10^{-9}$			Data Rate < 100 MBaud PR > -31 dBm Peak	Note 2

#### Notes:

1. Typical data at  $T_A = 25^\circ\text{C}$ ,  $V_{CC} = 5.0$  V dc, PECL serial interface.
2. Typical OPB was determined at a probability of error (BER) of  $10^{-9}$ . Lower probabilities of error can be achieved with short fibers that have less optical loss.

## HFBR-14X2/14X4 Low-Cost High-Speed Transmitters

### Description

The HFBR-14XX fiber optic transmitter contains an 820 nm AlGaAs emitter capable of efficiently launching optical power into four different optical fiber sizes: 50/125  $\mu\text{m}$ , 62.5/125  $\mu\text{m}$ , 100/140  $\mu\text{m}$ , and 200  $\mu\text{m}$  HCS<sup>®</sup>. This allows the designer flexibility in choosing the fiber size. The HFBR-14XX is designed to operate with the Hewlett-Packard HFBR-24XX fiber optic receivers.

The HFBR-14XX transmitter's high coupling efficiency allows the emitter to be driven at low current levels resulting in low power consumption and increased reliability of the transmitter. The HFBR-14X4 high power transmitter is optimized for small size

fiber and typically can launch -15.8 dBm optical power at 60 mA into 50/125  $\mu\text{m}$  fiber and -12 dBm into 62.5/125  $\mu\text{m}$  fiber. The HFBR-14X2 standard transmitter typically can launch -12 dBm of optical power at 60 mA into 100/140  $\mu\text{m}$  fiber cable. It is ideal for large size fiber such as 100/140  $\mu\text{m}$ . The high launched optical power level is useful for systems where star couplers, taps, or inline connectors create large fixed losses.

Consistent coupling efficiency is assured by the double-lens optical system (Figure 1). Power coupled into any of the three fiber types varies less than 5 dB from part to part at a given drive current and temperature. Consistent coupling efficiency reduces receiver dynamic range requirements which allows for longer link lengths.

### Housed Product

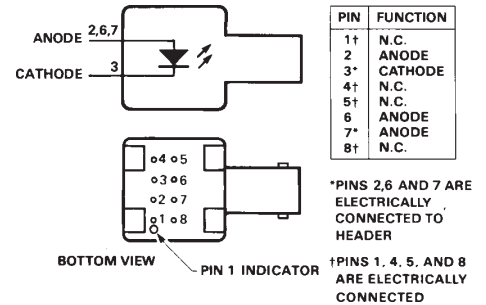

### Unhoused Product

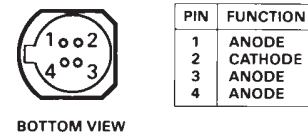

## Absolute Maximum Ratings

Parameter	Symbol	Min.	Max.	Units	Reference
Storage Temperature	$T_S$	-55	+85	$^{\circ}\text{C}$	
Operating Temperature	$T_A$	-40	+85	$^{\circ}\text{C}$	
Lead Soldering Cycle	Temp.		+260	$^{\circ}\text{C}$	
	Time		10	sec	
Forward Input Current	Peak	$I_{\text{FPK}}$	200	mA	Note 1
	dc	$I_{\text{Fdc}}$	100	mA	
Reverse Input Voltage	$V_{\text{BR}}$		1.8	V	

**Electrical/Optical Specifications** -40°C to +85°C unless otherwise specified.

Parameter	Symbol	Min.	Typ. <sup>[2]</sup>	Max.	Units	Conditions	Reference
Forward Voltage	V <sub>F</sub>	1.48	1.70	2.09	V	I <sub>F</sub> = 60 mA dc	Figure 9
			1.84			I <sub>F</sub> = 100 mA dc	
Forward Voltage Temperature Coefficient	ΔV <sub>F</sub> /ΔT		-0.22		mV/°C	I <sub>F</sub> = 60 mA dc	Figure 9
			-0.18			I <sub>F</sub> = 100 mA dc	
Reverse Input Voltage	V <sub>BR</sub>	1.8	3.8		V	I <sub>F</sub> = 100 μA dc	
Peak Emission Wavelength	λ <sub>P</sub>	792	820	865	nm		
Diode Capacitance	C <sub>T</sub>		55		pF	V = 0, f = 1 MHz	
Optical Power Temperature Coefficient	ΔP <sub>T</sub> /ΔT		-0.006		dB/°C	I = 60 mA dc	
			-0.010			I = 100 mA dc	
Thermal Resistance	θ <sub>JA</sub>		260		°C/W		Notes 3, 8
14X2 Numerical Aperture	NA		0.49				
14X4 Numerical Aperture	NA		0.31				
14X2 Optical Port Diameter	D		290		μm		Note 4
14X4 Optical Port Diameter	D		150		μm		Note 4

**HFBR-14X2 Output Power Measured Out of 1 Meter of Cable**

Parameter	Symbol	Min.	Typ. <sup>[2]</sup>	Max.	Unit	Conditions		Reference
50/125 μm Fiber Cable NA = 0.2	P <sub>T50</sub>	-21.8	-18.8	-16.8	dBm peak	T <sub>A</sub> = 25°C	I <sub>F</sub> = 60 mA dc	Notes 5, 6, 9
		-22.8		-15.8			I <sub>F</sub> = 100 mA dc	
		-20.3	-16.8	-14.4		T <sub>A</sub> = 25°C		
		-21.9		-13.8				
62.5/125 μm Fiber Cable NA = 0.275	P <sub>T62</sub>	-19.0	-16.0	-14.0	dBm peak	T <sub>A</sub> = 25°C	I <sub>F</sub> = 60 mA dc	
		-20.0		-13.0			I <sub>F</sub> = 100 mA dc	
		-17.5	-14.0	-11.6		T <sub>A</sub> = 25°C		
		-19.1		-11.0				
100/140 μm Fiber Cable NA = 0.3	P <sub>T100</sub>	-15.0	-12.0	-10.0	dBm peak	T <sub>A</sub> = 25°C	I <sub>F</sub> = 60 mA dc	
		16.0		-9.0			I <sub>F</sub> = 100 mA dc	
		-13.5	-10.0	-7.6		T <sub>A</sub> = 25°C		
		-15.1		-7.0				
200 μm HCS Fiber Cable NA = 0.37	P <sub>T200</sub>	-10.7	-7.1	-4.7	dBm peak	T <sub>A</sub> = 25°C	I <sub>F</sub> = 60 mA dc	
		-11.7		-3.7			I <sub>F</sub> = 100 mA dc	
		-9.2	-5.2	-2.3		T <sub>A</sub> = 25°C		
		-10.8		-1.7				

*CAUTION: The small junction sizes inherent to the design of these components increase the components' susceptibility to damage from electrostatic discharge (ESD). It is advised that normal static precautions be taken in handling and assembly of these components to prevent damage and/or degradation which may be induced by ESD.*



### HFBR-14X4 Output Power Measured out of 1 Meter of Cable

Parameter	Symbol	Min.	Typ. <sup>[2]</sup>	Max.	Unit	Conditions		Reference
50/125 $\mu\text{m}$ Fiber Cable NA = 0.2	PT50	-18.8	-15.8	-13.8	dBm peak	$T_A = 25^\circ\text{C}$	$I_F = 60 \text{ mA dc}$	Notes 5, 6, 9
		-19.8		-12.8				
		-17.3	-13.8	-11.4		$T_A = 25^\circ\text{C}$	$I_F = 100 \text{ mA dc}$	
		-18.9		-10.8				
62.5/125 $\mu\text{m}$ Fiber Cable NA = 0.275	PT62	-15.0	-12.0	-10.0	dBm peak	$T_A = 25^\circ\text{C}$	$I_F = 60 \text{ mA dc}$	
		-16.0		-9.0				
		-13.5	-10.0	-7.6		$T_A = 25^\circ\text{C}$	$I_F = 100 \text{ mA dc}$	
		-15.1		-7.0				
100/140 $\mu\text{m}$ Fiber Cable NA = 0.3	PT100	-9.5	-6.5	-4.5	dBm peak	$T_A = 25^\circ\text{C}$	$I_F = 60 \text{ mA dc}$	
		-10.5		-3.5				
		-8.0	-4.5	-2.1		$T_A = 25^\circ\text{C}$	$I_F = 100 \text{ mA dc}$	
		-9.6		-1.5				
200 $\mu\text{m}$ HCS Fiber Cable NA = 0.37	PT200	-5.2	-3.7	+0.8	dBm peak	$T_A = 25^\circ\text{C}$	$I_F = 60 \text{ mA dc}$	
		-6.2		+1.8				
		-3.7	-1.7	+3.2		$T_A = 25^\circ\text{C}$	$I_F = 100 \text{ mA dc}$	
		-5.3		+3.8				

### 14X2/14X4 Dynamic Characteristics

Parameter	Symbol	Min.	Typ. <sup>[2]</sup>	Max.	Units	Conditions	Reference
Rise Time, Fall Time (10% to 90%)	$t_r, t_f$		4.0	6.5	nsec No Pre-bias	$I_F = 60 \text{ mA}$ Figure 12	Note 7,
Rise Time, Fall Time (10% to 90%)	$t_r, t_f$		3.0		nsec	$I_F = 10 \text{ to } 100 \text{ mA}$	Note 7, Figure 11
Pulse Width Distortion	PWD		0.5		nsec		Figure 11

#### Notes:

- For  $I_{FPK} > 100 \text{ mA}$ , the time duration should not exceed 2 ns.
- Typical data at  $T_A = 25^\circ\text{C}$ .
- Thermal resistance is measured with the transmitter coupled to a connector assembly and mounted on a printed circuit board.
- D is measured at the plane of the fiber face and defines a diameter where the optical power density is within 10 dB of the maximum.
- $P_T$  is measured with a large area detector at the end of 1 meter of mode stripped cable, with an ST<sup>®</sup> precision ceramic ferrule (MIL-STD-83522/13) for HFBR-1412/1414, and with an SMA 905 precision ceramic ferrule for HFBR-1402/1404.
- When changing  $\mu\text{W}$  to dBm, the optical power is referenced to 1 mW (1000  $\mu\text{W}$ ). Optical Power P (dBm) =  $10 \log P (\mu\text{W})/1000 \mu\text{W}$ .
- Pre-bias is recommended if signal rate  $> 10 \text{ MBd}$ , see recommended drive circuit in Figure 11.
- Pins 2, 6 and 7 are welded to the anode header connection to minimize the thermal resistance from junction to ambient. To further reduce the thermal resistance, the anode trace should be made as large as is consistent with good RF circuit design.
- Fiber NA is measured at the end of 2 meters of mode stripped fiber, using the far-field pattern. NA is defined as the sine of the half angle, determined at 5% of the peak intensity point. When using other manufacturer's fiber cable, results will vary due to differing NA values and specification methods.

**All HFBR-14XX LED transmitters are classified as IEC 825-1 Accessible Emission Limit (AEL) Class 1 based upon the current proposed draft scheduled to go in to effect on January 1, 1997. AEL Class 1 LED devices are considered eye safe. Contact your Hewlett-Packard sales representative for more information.**

*CAUTION: The small junction sizes inherent to the design of these components increase the components' susceptibility to damage from electrostatic discharge (ESD). It is advised that normal static precautions be taken in handling and assembly of these components to prevent damage and/or degradation which may be induced by ESD.*

## Recommended Drive Circuits

The circuit used to supply current to the LED transmitter can significantly influence the optical switching characteristics of the LED. The optical rise/fall times and propagation delays can be improved by using the appropriate circuit techniques. The LED drive circuit shown in

Figure 11 uses frequency compensation to reduce the typical rise/fall times of the LED and a small pre-bias voltage to minimize propagation delay differences that cause pulse-width distortion. The circuit will typically produce rise/fall times of 3 ns, and a total jitter including pulse-width distortion of less than 1 ns. This circuit is recommended for applications requiring low edge jitter

or high-speed data transmission at signal rates of up to 155 MBd. Component values for this circuit can be calculated for different LED drive currents using the equations shown below. For additional details about LED drive circuits, the reader is encouraged to read Hewlett-Packard Application Bulletin 78 and Application Note 1038.

$$R_y = \frac{(V_{CC} - V_F) + 3.97 (V_{CC} - V_F - 1.6 \text{ V})}{I_{F ON} (\text{A})}$$

$$R_{X1} = \frac{1}{2} \left( \frac{R_y}{3.97} \right)$$

$$R_{EQ2}(\Omega) = R_{X1} - 1$$

$$R_{X2} = R_{X3} = R_{X4} = 3(R_{EQ2})$$

$$C(\text{pF}) = \frac{2000(\text{ps})}{R_{X1}(\Omega)}$$

*Example for  $I_{F ON} = 100 \text{ mA}$ :  $V_F$  can be obtained from Figure 9 (= 1.84 V).*

$$R_y = \frac{(5 - 1.84) + 3.97 (5 - 1.84 - 1.6)}{0.100}$$

$$R_y = \frac{3.16 + 6.19}{0.100} = 93.5 \Omega$$

$$R_{X1} = \frac{1}{2} \left( \frac{93.5}{3.97} \right) = 11.8 \Omega$$

$$R_{EQ2} = 11.8 - 1 = 10.8 \Omega$$

$$R_{X2} = R_{X3} = R_{X4} = 3(10.8) = 32.4 \Omega$$

$$C = \frac{2000 \text{ ps}}{11.8 \Omega} = 169 \text{ pF}$$

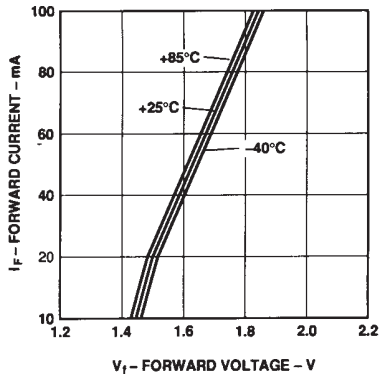

Figure 9. Forward Voltage and Current Characteristics.

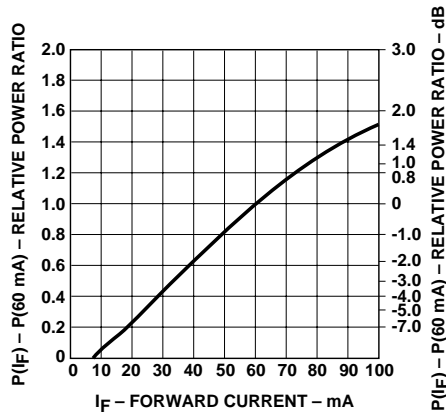

Figure 10. Normalized Transmitter Output vs. Forward Current.

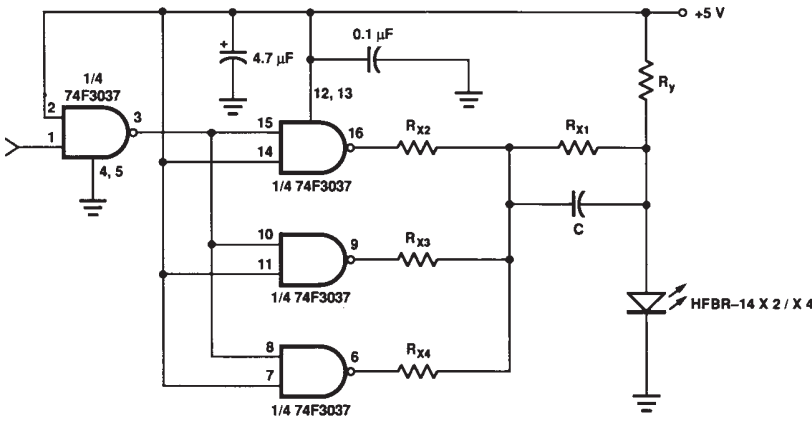

Figure 11. Recommended Drive Circuit.

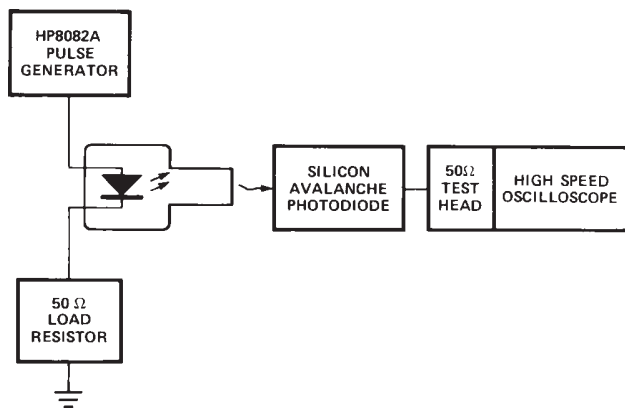

Figure 12. Test Circuit for Measuring  $t_r$ ,  $t_f$ .

## HFBR-24X2 Low-Cost 5 MBd Receiver

### Description

The HFBR-24X2 fiber optic receiver is designed to operate with the Hewlett-Packard HFBR-14XX fiber optic transmitter and 50/125  $\mu\text{m}$ , 62.5/125  $\mu\text{m}$ , 100/140  $\mu\text{m}$ , and 200  $\mu\text{m}$  HCS<sup>®</sup> fiber optic cable. Consistent coupling into the receiver is assured by the lensed optical system (Figure 1). Response does not vary with fiber size  $\leq 0.100 \mu\text{m}$ .

The HFBR-24X2 receiver incorporates an integrated photo IC containing a photodetector and dc amplifier driving an open-collector Schottky output transistor. The HFBR-24X2 is

designed for direct interfacing to popular logic families. The absence of an internal pull-up resistor allows the open-collector output to be used with logic families such as CMOS requiring voltage excursions much higher than  $V_{CC}$ .

Both the open-collector "Data" output Pin 6 and  $V_{CC}$  Pin 2 are referenced to "Com" Pin 3, 7. The "Data" output allows busing, strobing and wired "OR" circuit configurations. The transmitter is designed to operate from a single +5 V supply. It is essential that a bypass capacitor (0.1  $\mu\text{F}$  ceramic) be connected from Pin 2 ( $V_{CC}$ ) to Pin 3 (circuit common) of the receiver.

### Housed Product

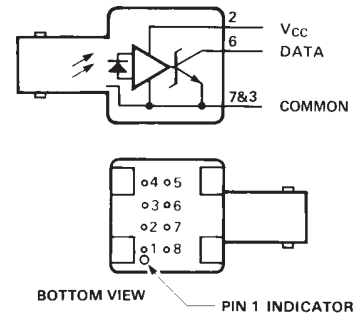

PIN	FUNCTION
1†	N.C.
2	$V_{CC}$ (5 V)
3*	COMMON
4†	N.C.
5†	N.C.
6	DATA
7*	COMMON
8†	N.C.

\*PINS 3 AND 7 ARE ELECTRICALLY CONNECTED TO HEADER

†PINS 1, 4, 5, AND 8 ARE ELECTRICALLY CONNECTED

### Unhoused Product

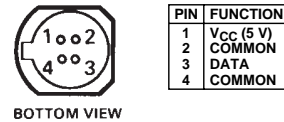

PIN	FUNCTION
1	$V_{CC}$ (5 V)
2	COMMON
3	DATA
4	COMMON

### Absolute Maximum Ratings

Parameter	Symbol	Min.	Max.	Units	Reference
Storage Temperature	$T_S$	-55	+85	$^{\circ}\text{C}$	
Operating Temperature	$T_A$	-40	+85	$^{\circ}\text{C}$	
Lead Soldering Cycle	Temp.		+260	$^{\circ}\text{C}$	Note 1
	Time		10	sec	
Supply Voltage	$V_{CC}$	-0.5	7.0	V	
Output Current	$I_O$		25	mA	
Output Voltage	$V_O$	-0.5	18.0	V	
Output Collector Power Dissipation	$P_{OAV}$		40	mW	
Fan Out (TTL)	N		5		Note 2

## Electrical/Optical Characteristics -40°C to + 85°C unless otherwise specified

Fiber sizes with core diameter  $\leq 100 \mu\text{m}$  and  $\text{NA} \leq 0.35$ ,  $4.75 \text{ V} \leq V_{\text{CC}} \leq 5.25 \text{ V}$

Parameter	Symbol	Min.	Typ. <sup>[3]</sup>	Max.	Units	Conditions	Reference
High Level Output Current	$I_{\text{OH}}$		5	250	$\mu\text{A}$	$V_{\text{O}} = 18$ $P_{\text{R}} < -40 \text{ dBm}$	
Low Level Output Voltage	$V_{\text{OL}}$		0.4	0.5	V	$I_{\text{O}} = 8 \text{ mA}$ $P_{\text{R}} > -24 \text{ dBm}$	
High Level Supply Current	$I_{\text{CCH}}$		3.5	6.3	mA	$V_{\text{CC}} = 5.25 \text{ V}$ $P_{\text{R}} < -40 \text{ dBm}$	
Low Level Supply Current	$I_{\text{CCL}}$		6.2	10	mA	$V_{\text{CC}} = 5.25 \text{ V}$ $P_{\text{R}} > -24 \text{ dBm}$	
Equivalent N.A.	NA		0.50				
Optical Port Diameter	D		400		$\mu\text{m}$		Note 4

## Dynamic Characteristics

-40°C to +85°C unless otherwise specified;  $4.75 \text{ V} \leq V_{\text{CC}} \leq 5.25 \text{ V}$ ;  $\text{BER} \leq 10^{-9}$

Parameter	Symbol	Min.	Typ. <sup>[3]</sup>	Max.	Units	Conditions	Reference
Peak Optical Input Power Logic Level HIGH	$P_{\text{RH}}$			-40	dBm pk	$\lambda_{\text{P}} = 820 \text{ nm}$	Note 5
				0.1	$\mu\text{W pk}$		
Peak Optical Input Power Logic Level LOW	$P_{\text{RL}}$	-25.4		-9.2	dBm pk	$T_{\text{A}} = +25^{\circ}\text{C}$ , $I_{\text{OL}} = 8 \text{ mA}$	Note 5
		2.9		120	$\mu\text{W pk}$		
		-24.0		-10.0	dBm pk	$I_{\text{OL}} = 8 \text{ mA}$	
		4.0		100	$\mu\text{W pk}$		
Propagation Delay LOW to HIGH	$t_{\text{PLHR}}$		65		ns	$T_{\text{A}} = 25^{\circ}\text{C}$ , $P_{\text{R}} = -21 \text{ dBm}$ , Data Rate = 5 MBd	Note 6
Propagation Delay HIGH to LOW	$t_{\text{PHLR}}$		49		ns		

### Notes:

- 2.0 mm from where leads enter case.
- 8 mA load (5 x 1.6 mA),  $R_{\text{L}} = 560 \Omega$ .
- Typical data at  $T_{\text{A}} = 25^{\circ}\text{C}$ ,  $V_{\text{CC}} = 5.0 \text{ Vdc}$ .
- D is the effective diameter of the detector image on the plane of the fiber face. The numerical value is the product of the actual detector diameter and the lens magnification.
- Measured at the end of 100/140  $\mu\text{m}$  fiber optic cable with large area detector.
- Propagation delay through the system is the result of several sequentially-occurring phenomena. Consequently it is a combination of data-rate-limiting effects and of transmission-time effects. Because of this, the data-rate limit of the system must be described in terms of time differentials between delays imposed on falling and rising edges.
- As the cable length is increased, the propagation delays increase at 5 ns per meter of length. Data rate, as limited by pulse width distortion, is not affected by increasing cable length if the optical power level at the receiver is maintained.

**CAUTION:** The small junction sizes inherent to the design of these components increase the components' susceptibility to damage from electrostatic discharge (ESD). It is advised that normal static precautions be taken in handling and assembly of these components to prevent damage and/or degradation which may be induced by ESD.

## HFBR-24X6 Low-Cost 125 MHz Receiver Description

The HFBR-24X6 fiber optic receiver is designed to operate with the Hewlett-Packard HFBR-14XX fiber optic transmitters and 50/125  $\mu\text{m}$ , 62.5/125  $\mu\text{m}$ , 100/140  $\mu\text{m}$  and 200  $\mu\text{m}$  HCS<sup>®</sup> fiber optic cable. Consistent coupling into the receiver is assured by the lensed optical system (Figure 1). Response does not vary with fiber size for core diameters of 100  $\mu\text{m}$  or less.

The receiver output is an analog signal which allows follow-on circuitry to be optimized for a variety of distance/data rate requirements. Low-cost external components can be used to convert the analog output to logic compatible signal levels for various data formats and data rates up to 175 MBd. This distance/data rate tradeoff results in increased optical power budget at lower data rates which can be used for additional distance or splices.

The HFBR-24X6 receiver contains a PIN photodiode and low noise transimpedance pre-amplifier

integrated circuit. The HFBR-24X6 receives an optical signal and converts it to an analog voltage. The output is a buffered emitter-follower. Because the signal amplitude from the HFBR-24X6 receiver is much larger than from a simple PIN photodiode, it is less susceptible to EMI, especially at high signaling rates. For very noisy environments, the conductive or metal port option is recommended. A receiver dynamic range of 23 dB over temperature is achievable (assuming  $10^{-9}$  BER).

The frequency response is typically dc to 125 MHz. Although the HFBR-24X6 is an analog receiver, it is compatible with digital systems. Please refer to Application Bulletin 78 for simple and inexpensive circuits that operate at 155 MBd or higher.

The recommended ac coupled receiver circuit is shown in Figure 12. It is essential that a 10 ohm resistor be connected between pin 6 and the power supply, and a 0.1  $\mu\text{F}$  ceramic bypass capacitor be connected between the power supply and ground. In addition, pin 6 should be filtered to protect the

receiver from noisy host systems. Refer to AN 1038, 1065, or AB 78 for details.

### Housed Product

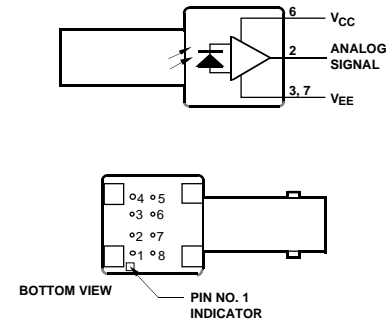

PIN	FUNCTION
1†	N.C.
2	SIGNAL
3*	VEE
4†	N.C.
5†	N.C.
6	VCC
7*	VEE
8†	N.C.

\* PINS 3 AND 7 ARE ELECTRICALLY CONNECTED TO THE HEADER.

† PINS 1, 4, 5, AND 8 ARE ISOLATED FROM THE INTERNAL CIRCUITRY, BUT ARE ELECTRICALLY CONNECTED TO EACH OTHER.

### Unhoused Product

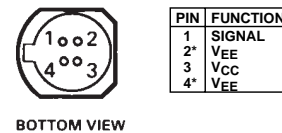

PIN	FUNCTION
1	SIGNAL
2*	VEE
3	VCC
4*	VEE

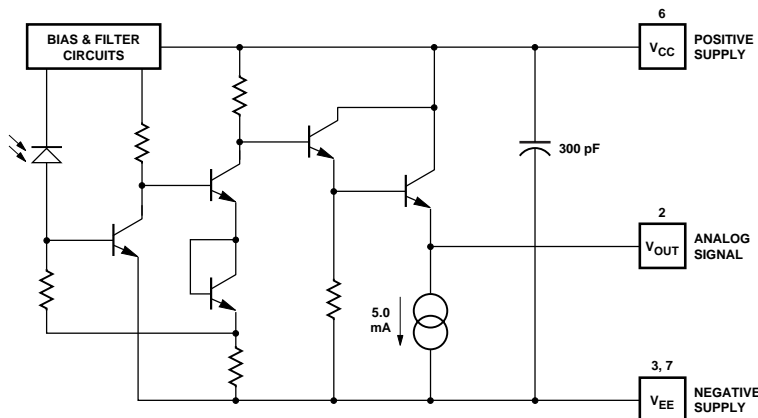

Figure 11. Simplified Schematic Diagram.

**CAUTION:** The small junction sizes inherent to the design of these components increase the components' susceptibility to damage from electrostatic discharge (ESD). It is advised that normal static precautions be taken in handling and assembly of these components to prevent damage and/or degradation which may be induced by ESD.

## Absolute Maximum Ratings

Parameter	Symbol	Min.	Max.	Units	Reference
Storage Temperature	$T_S$	-55	+85	°C	
Operating Temperature	$T_A$	-40	+85	°C	
Lead Soldering Cycle	Temp.		+260	°C	Note 1
	Time		10	s	
Supply Voltage	$V_{CC}$	-0.5	6.0	V	
Output Current	$I_O$		25	mA	
Signal Pin Voltage	$V_{SIG}$	-0.5	$V_{CC}$	V	

**Electrical/Optical Characteristics** -40°C to +85°C; 4.75 V ≤ Supply Voltage ≤ 5.25 V,  
 $R_{LOAD} = 511 \Omega$ , Fiber sizes with core diameter ≤ 100 μm, and N.A. ≤ -0.35 unless otherwise specified

Parameter	Symbol	Min.	Typ. <sup>[2]</sup>	Max.	Units	Conditions	Reference
Responsivity	$R_P$	5.3	7	9.6	mV/μW	$T_A = 25^\circ\text{C}$ @ 820 nm, 50 MHz	Note 3, 4 Figure 16
		4.5		11.5	mV/μW	@ 820 nm, 50 MHz	
RMS Output Noise Voltage	$V_{NO}$		0.40	0.59	mV	Bandwidth Filtered @ 75 MHz $P_R = 0 \mu\text{W}$	Note 5
				0.70	mV	Unfiltered Bandwidth $P_R = 0 \mu\text{W}$	Figure 13
Equivalent Input Optical Noise Power (RMS)	$P_N$		-43.0	-41.4	dBm	Bandwidth Filtered @ 75 MHz	
			0.050	0.065	μW		
Optical Input Power (Overdrive)	$P_R$			-7.6	dBm pk	$T_A = 25^\circ\text{C}$	Figure 14 Note 6
				175	μW pk		
				-8.2	dBm pk		
				150	μW pk		
Output Impedance	$Z_o$		30		Ω	Test Frequency = 50 MHz	
dc Output Voltage	$V_{o\ dc}$	-4.2	-3.1	-2.4	V	$P_R = 0 \mu\text{W}$	
Power Supply Current	$I_{EE}$		9	15	mA	$R_{LOAD} = 510 \Omega$	
Equivalent N.A.	NA		0.35				
Equivalent Diameter	D		324		μm		Note 7

**CAUTION:** The small junction sizes inherent to the design of these components increase the components' susceptibility to damage from electrostatic discharge (ESD). It is advised that normal static precautions be taken in handling and assembly of these components to prevent damage and/or degradation which may be induced by ESD.

**Dynamic Characteristics** -40°C to +85°C; 4.75 V ≤ Supply Voltage ≤ 5.25 V; R<sub>LOAD</sub> = 511 Ω, C<sub>LOAD</sub> = 5 pF unless otherwise specified

Parameter	Symbol	Min.	Typ. <sup>[2]</sup>	Max.	Units	Conditions	Reference
Rise/Fall Time 10% to 90%	t <sub>r</sub> , t <sub>f</sub>		3.3	6.3	ns	P <sub>R</sub> = 100 μW peak	Figure 15
Pulse Width Distortion	PWD		0.4	2.5	ns	P <sub>R</sub> = 150 μW peak	Note 8, Figure 14
Overshoot			2		%	P <sub>R</sub> = 5 μW peak, t <sub>r</sub> = 1.5 ns	Note 9
Bandwidth (Electrical)	BW		125		MHz	-3 dB Electrical	
Bandwidth - Rise Time Product			0.41		Hz • s		Note 10

**Notes:**

- 2.0 mm from where leads enter case.
- Typical specifications are for operation at T<sub>A</sub> = 25°C and V<sub>CC</sub> = +5 V dc.
- For 200 μm HCS fibers, typical responsivity will be 6 mV/μW. Other parameters will change as well.
- Pin #2 should be ac coupled to a load ≥ 510 ohm. Load capacitance must be less than 5 pF.
- Measured with a 3 pole Bessel filter with a 75 MHz, -3 dB bandwidth. Recommended receiver filters for various bandwidths are provided in Application Bulletin 78.
- Overdrive is defined at PWD = 2.5 ns.
- D is the effective diameter of the detector image on the plane of the fiber face. The numerical value is the product of the actual detector diameter and the lens magnification.
- Measured with a 10 ns pulse width, 50% duty cycle, at the 50% amplitude point of the waveform.
- Percent overshoot is defined as:  

$$\left( \frac{V_{PK} - V_{100\%}}{V_{100\%}} \right) \times 100\%$$
- The conversion factor for the rise time to bandwidth is 0.41 since the HFBR-24X6 has a second order bandwidth limiting characteristic.

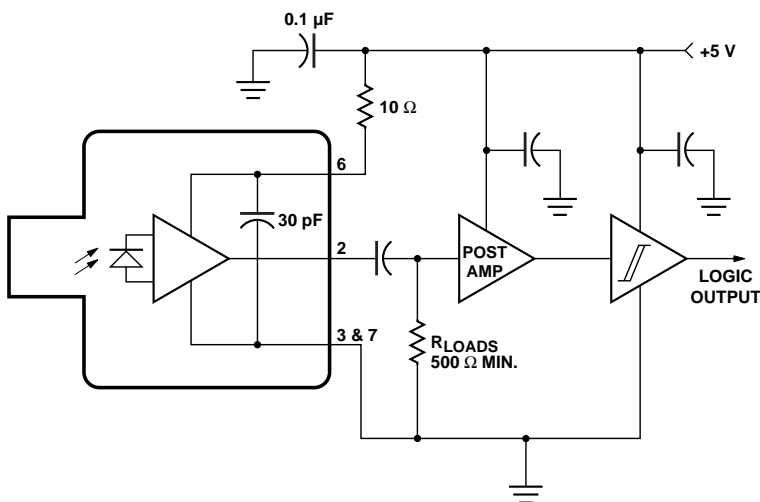

**Figure 12. Recommended ac Coupled Receiver Circuit. (See AB 78 and AN 1038 for more information.)**

**CAUTION:** The small junction sizes inherent to the design of these components increase the components' susceptibility to damage from electrostatic discharge (ESD). It is advised that normal static precautions be taken in handling and assembly of these components to prevent damage and/or degradation which may be induced by ESD.



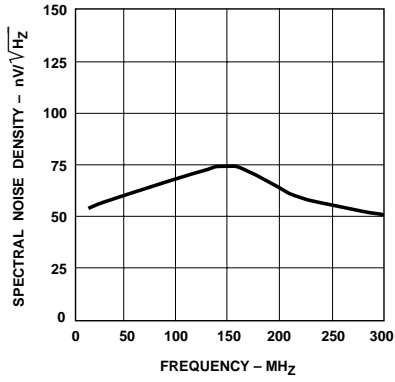

Figure 13. Typical Spectral Noise Distortion vs. Peak Input Power.

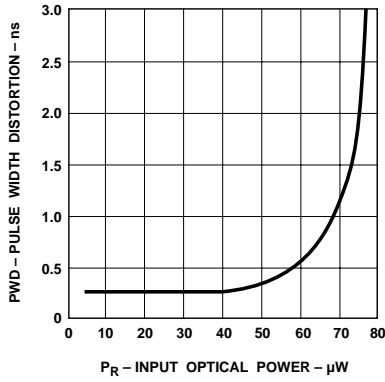

Figure 14. Typical Pulse Width Distortion vs. Frequency.

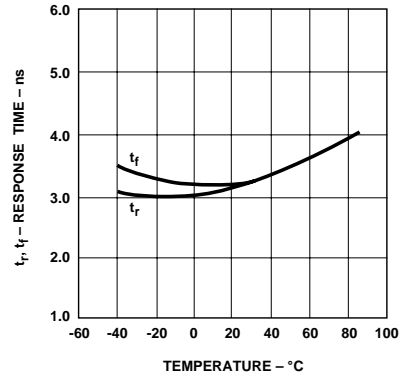

Figure 15. Typical Rise and Fall Times vs. Temperature.

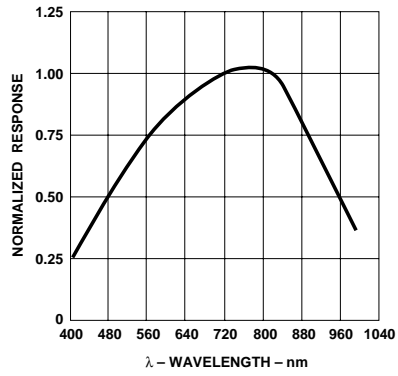

Figure 16. Receiver Spectral Response Normalized to 820 nm.

# Conductive Port Option for Low Cost Miniature Link Components

## Technical Data

### Features

- **Significantly Decreases Effect of Electromagnetic Interference (EMI) on Receiver Sensitivity**
- **Available with Both SMA and Threaded ST Styled Port Receivers**
- **Allows the Designer to Separate the Signal and Conductive Port Grounds**

### Description

The conductive port option for the Low Cost Miniature Link component family consists of a grounding path from the conductive port to four grounding pins as shown in the package outline drawing. Signal ground is separate from the four grounding pins to give the designer more flexibility. This option is available with all SMA and ST panel mount styled port receivers. Electrical/optical performance of the receivers is not affected by the conductive port. Refer to the HFBR-0400 data sheets for more information.

### Applications

HP recommends that the designer use separate ground paths for the signal ground and the conductive port ground in order to minimize the effects of coupled noise on the receiver circuitry. If the designer notices that extreme noise is present on the system chassis, care should be taken to electrically isolate the conductive port from the chassis.

In the case of ESD, the conductive port option does not alleviate the need for system recovery procedures. A 15 kV ESD event entering through the port will not

### Option C



cause catastrophic failure for any HFBR-0400 receivers, but may cause soft errors. The conductive port option can reduce the amount of soft errors due to ESD events, but does not guarantee error-free performance.

### Package Outline

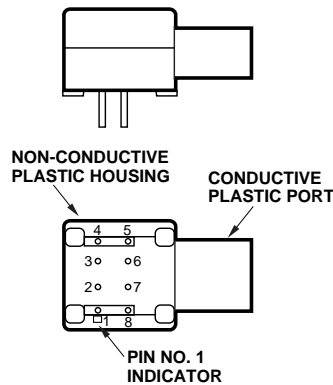

Pin	Function
1	Port Ground Pin
2	Part Dependent
3	Part Dependent
4	Port Ground Pin
5	Port Ground Pin
6	Part Dependent
7	Part Dependent
8	Port Ground Pin

### Reliability Information

Low Cost Miniature Link components with the Conductive Port Option are as reliable as standard HFBR-0400 components. The following tests were performed to verify the mechanical reliability of this option.

### Ordering Information

To order the Conductive Port Option with a particular receiver component, place a "C" after the base part number. For example, to order an HFBR-2406 with this option, order an HFBR-2406C. As another example, to order an HFBR-2416T with this option, order an HFBR-2416TC.

This option is available with the following part numbers:

HFBR-2402	HFBR-2442T
HFBR-2404	HFBR-2444T
HFBR-2406	HFBR-2446T
HFBR-2412T	HFBR-2452
HFBR-2414T	HFBR-2454
HFBR-2416T	HFBR-2456
HFBR-2432	HFBR-2462T
HFBR-2434	HFBR-2464T
HFBR-2436	HFBR-2466T

### Mechanical and Environmental Tests <sup>[1]</sup>

Test	MIL-STD-883/ Other Reference	Test Conditions	Units Tested	Total Failed
Temperature Cycling	1010 Condition B	-55°C to +125°C 15 min. dwell/5 min. transfer 100 cycles	70	0
Thermal Shock	1011 Condition B	-55°C to +125°C 5 min. dwell/10 sec. transfer 500 cycles	45	0
High temp. Storage	1008 Condition B	T <sub>A</sub> = 125°C 1000 hours	50	0
Mechanical Shock	2002 Condition B	1500 g/0.5 ms 5 impacts each axis	40	0
Port <sup>[2]</sup> Strength	T <sub>A</sub> = 25°C	6 Kg-cm no port damage	20	0
Seal Dye Penetrant (Zyglo)	1014 Condition D	45 psi, 10 hours No leakage into microelectronic cavity	15	0
Solderability	2003	245°C	10	0
Resistance to Solvents	2015	3 one min. immersion brush after solvent	13`	0
Chemical Resistance	-	5 minutes in Acetone, Methanol, Boiling Water	12	0
Temperature- Humidity	-	T <sub>A</sub> = 85°C, RH = 85% Biased, 500 hours	30	0
Lead Integrity	2004 Condition B2	8 oz. wt. to each lead tested for three 90° arcs of the case	16	0
Electrostatic Discharge (ESD)	IEC-801-2	Direct contact discharge to port, 0-15 kV <sup>[3]</sup>	16	0

#### Notes:

- Tests were performed on both SMA and ST products with the conductive port option.
- The Port Strength test was designed to address the concerns with hand tightening the SMA connector to the fiber optic port. The limit is set to a level beyond most reasonable hand fastening loading.
- HP has previously used an air discharge method to measure ESD; results using this method vary with air temperature and humidity. The direct contact discharge method is preferred due to better repeatability and conformance with IEC procedures. ESD immunity measured with the air discharge method is generally higher than with the direct contact discharge method.

# Threaded ST Port Option for Low Cost Miniature Link Components

## Technical Data

### Features

- **Threading Allows ST Styled Port Components to be Panel Mounted**
- **Compatible with all Current Makes of ST Multimode Connectors**
- **Mechanical Dimensions are Compliant with MIL-STD-83522/13**

### Description

Low Cost Miniature Link components with the Threaded ST Port Option come with 0.2 inch (5.1 mm) of 3/8-32 UNEF-2A threads on the port. This option is available with all HFBR-0400, ST styled port components. Components with this option retain the same superior electrical/optical and mechanical performance as that of the base HFBR-0400 components. Refer to the HFBR-0400 data sheets for more information on electrical/optical performance and the HFBR-0400 Reliability data sheet for more information on mechanical durability.

### Panel Mounting

Low Cost Miniature Link components with the Threaded ST Port Option are suitable for panel mounting to chassis walls. The maximum wall thickness possible when using nuts and washers from the HFBR-4411 kit is 0.11 inch (2.8 mm).

### Option T



### Package Outline

#### Housed Product

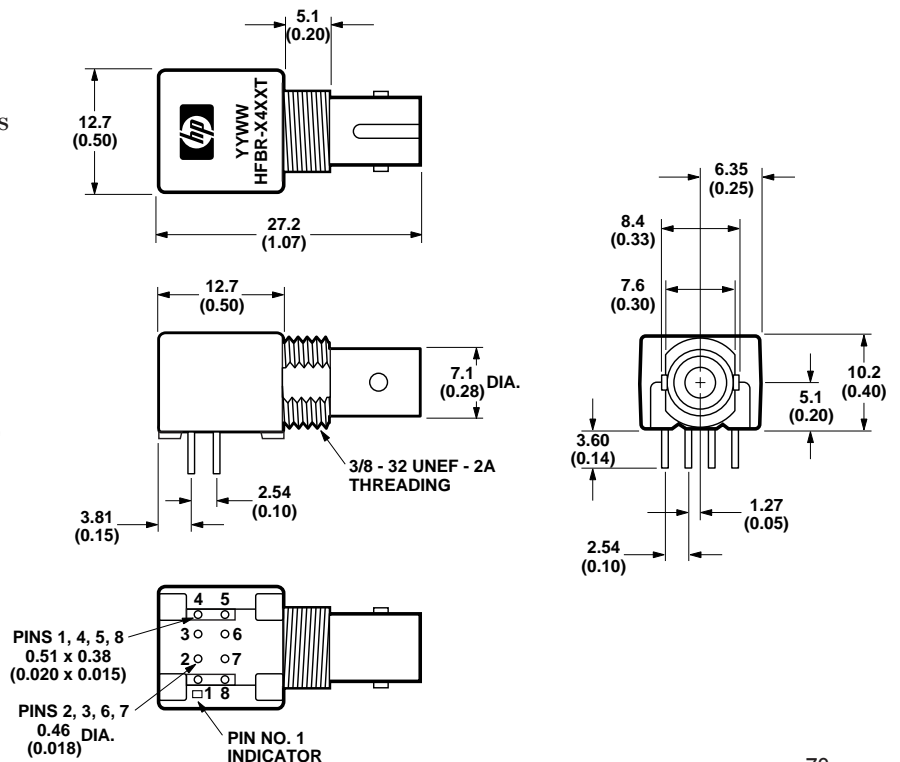

**Package Outline**  
Port Product

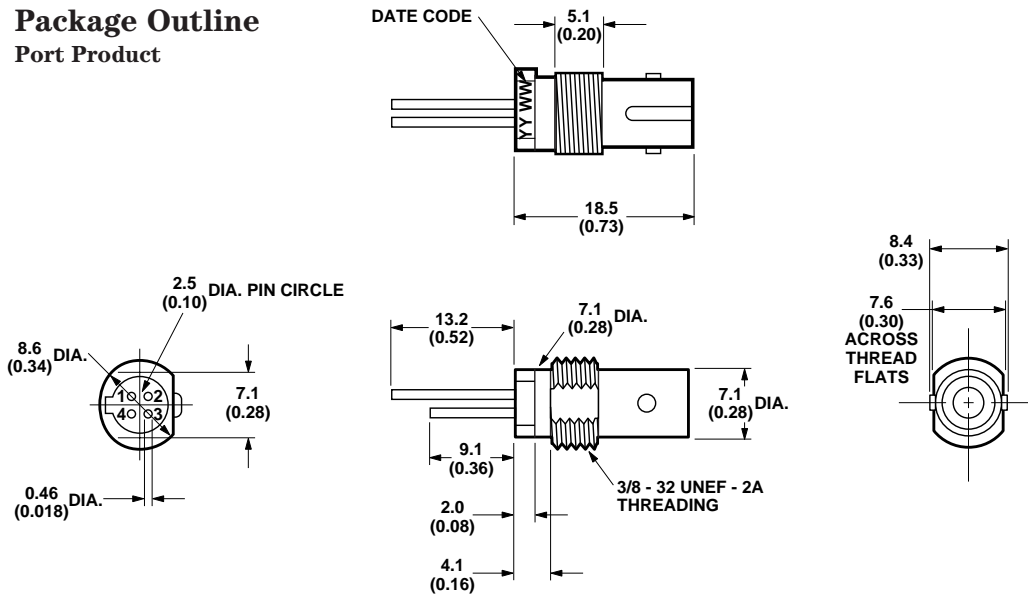

ALL DIMENSIONS IN MILLIMETERS AND (INCHES).

The HFBR-4411 kit consists of 100 nuts and 100 washers with dimensions as shown in Figure 1. These kits are available from HP or any authorized distributor. Any standard size nut and washer will work, provided the total thickness of the wall, nut, and washer does not exceed 0.2 inch (5.1mm).

When preparing the chassis wall for panel mounting, use the

mounting template in Figure 2. When tightening the nut, torque should not exceed 0.8 N-m (8.0 in-lb).

**Ordering Information**

To order the Threaded ST Port Option with a particular component, place a "T" after the base part number. For example, to order an HFBR-2416 with this option, order an HFBR-2416T.

This option is available with the following part numbers:

- HFBR-1412
- HFBR-1414
- HFBR-1442
- HFBR-1444
- HFBR-1462
- HFBR-1464
- HFBR-2412
- HFBR-2414

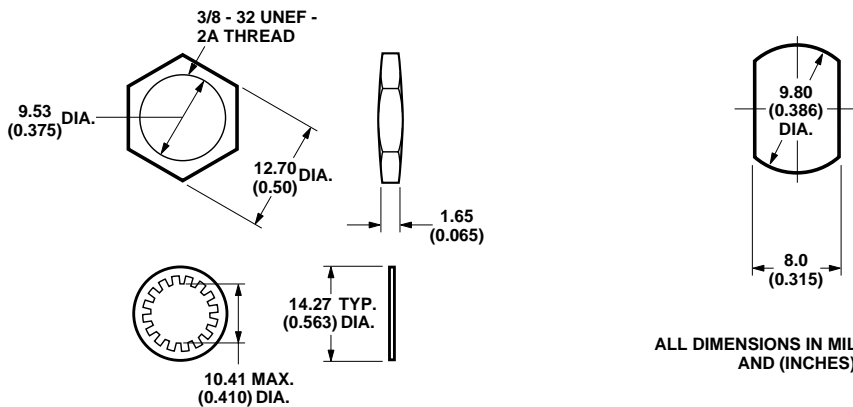

ALL DIMENSIONS IN MILLIMETERS AND (INCHES).

INTERNAL TOOTH LOCK WASHER

ALL DIMENSIONS IN MILLIMETERS AND (INCHES).

Figure 1. HFBR-4411 Mechanical Dimensions.

Figure 2. Recommended Cut-out for Panel Mounting.

---

# Metal Port Option for HFBR-0400 Series Components

## Technical Data

### Features

- **Nickel Plated Aluminum Connector Receptacle**
- **Withstands Electro-static Discharge (ESD) of 15 kV to the Port**
- **Significantly Decreases Effect of Electro-magnetic Interference (EMI) on Receiver Sensitivity**
- **Allows Separate Signal and Metal Port Grounds**
- **Available with SMA, ST, Threaded ST, and FC Styled Ports**

### Description

The metal port option for the HFBR-0400 Series gives designers the ability to have a metal connector receptacle with the familiar HFBR-0400 dual in-line package (DIP). The metal port option components have an internal electrical connection between the metal port and the four grounding pins, as shown in the package outline drawing. Signal ground is separate from the four grounding pins to give the flexibility in connecting the port to signal or chassis ground.

This feature aids in maintaining the integrity of the signal ground if the chassis is exposed to electrical noise. In addition, when the metal port is in good electrical contact with a well-grounded chassis, the metal port provides additional EMI shielding from electrically noisy circuits.

### Applications

HP recommends that the designer use separate ground paths for the signal ground and the conductive metal port ground in order to minimize the effects of external coupled noise on receiver circuitry. If noise is present on the system chassis, care should be taken to electrically isolate the metal port from the chassis.

In the case of ESD, the metal port option does not alleviate the need for system recovery procedures. A 15 kV ESD event entering through the connector port will not cause catastrophic failure, but the metal port does not guarantee error-free performance during an ESD event.

### Option M

---

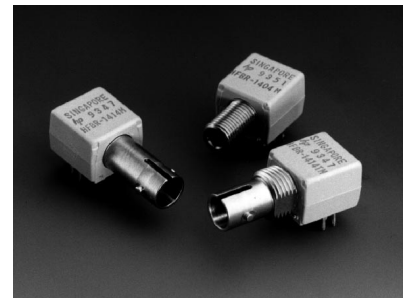

The Metal Port Option is available with SMA, ST, Threaded ST (panel mount) and FC styled port transmitters and receivers. The electrical/optical specifications, the mechanical dimensions, and the pinouts of the components with metal ports are identical to the standard plastic port products.

## Package Outline

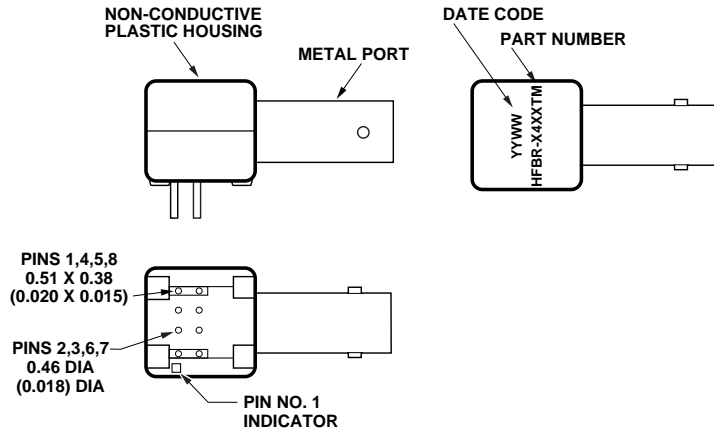

Pin	Function
1	Port Ground Pin
2	Part Dependent
3	Part Dependent
4	Port Ground Pin
5	Port Ground Pin
6	Part Dependent
7	Part Dependent
8	Port Ground Pin

## Ordering Information

This option will be available with the following part numbers:

### Transmitters

HFBR-1402  
HFBR-1412  
HFBR-1412T  
HFBR-1422  
HFBR-1404  
HFBR-1414  
HFBR-1414T  
HFBR-1424

### Receivers

HFBR-2402  
HFBR-2412  
HFBR-2412T  
HFBR-2422  
HFBR-2406  
HFBR-2416  
HFBR-2416T  
HFBR-2426

Refer to the HFBR-14XX and HFBR-24XX data sheets for electrical/optical/mechanical specifications for each part. To order the Metal Port Option with a particular transmitter or receiver component, simply add the letter "M" to the end of the standard part number. For example, HFBR-1412T with the metal port option is HFBR-1412TM.

## Reliability Information

Low Cost Miniature Link Components with the Metal Port Option use the same semi-conductor devices and manufacturing processes as standard HFBR-0400 components, so reliability data for the HFBR-0400 Series is directly applicable. The tests listed below demonstrate the mechanical reliability of this package.

## Mechanical and Environmental Tests

Test	MIL-STD-883 or Other Reference	Test Conditions	Units Tested	Total Failed
Temperature Cycling	1010 Condition B	-55 to +125°C, 15 minutes dwell, 5 minutes transfer, 170 cycles	40	0
Unbiased Pressure Pot Test		121°C, 100% relative humidity, 2 atmospheres, 48 hours	5	0
Mechanical Shock	2002 Condition B	5 blows each X1, X2, Y1, Y2, Z1, Z2 1500 G, 0.5 msec. pulse	40	0
Vibration Variable Frequency	2007 Condition A	50 G, 20 to 2000 Hz. 4, 4 minute cycles each X, Y, Z	40	0