

# Analog Isolation Amplifier

## Technical Data

### Features

- **High Common Mode Rejection (CMR): 15 kV/μs at  $V_{CM} = 1000\text{ V}$**
- **5% Gain Tolerance**
- **0.1% Nonlinearity**
- **Low Offset Voltage and Offset Temperature Coefficient**
- **100 kHz Bandwidth**
- **Performance Specified Over -40°C to 85°C Temperature Range**
- **Recognized Under UL 1577 and CSA Approved for Dielectric Withstand Proof Test Voltage of 2500 Vac, 1 Minute**
- **Standard 8-Pin DIP Package**

### Applications

- **Motor Phase and Rail Current Sensing**
- **Inverter Current Sensing**
- **Switched Mode Power Supply Signal Isolation**
- **General Purpose Current Sensing and Monitoring**
- **General Purpose Analog Signal Isolation**

### Description

The HCPL-7840 isolation amplifier provides accurate, electrically isolated and amplified representations of voltage and current.

When used with a shunt resistor in the current path, the HCPL-7840 offers superior reliability, cost effectiveness, size and autoinsertability compared with the traditional solutions such as current transformers and Hall-effect sensors.

The HCPL-7840 consists of a sigma-delta analog-to-digital converter optically coupled to a digital-to-analog converter. Superior performance in design critical specifications such as common-mode rejection, offset voltage, nonlinearity, operating temperature range and regulatory compliance make the HCPL-7840 the clear choice for designing reliable, lower-cost, reduced-size products such as motor controllers and inverters.

Common-mode rejection of 15 kV/μs makes the HCPL-7840 suitable for noisy electrical

### HCPL-7840

environments such as those generated by the high switching rates of power IGBTs.

Low offset voltage together with a low offset voltage temperature coefficient permits accurate use of auto-calibration techniques.

Gain tolerance of 5% with 0.1% nonlinearity further provide the performance necessary for accurate feedback and control.

A wide operating temperature range with specified performance allows the HCPL-7840 to be used in hostile industrial environments.

### Functional Diagram

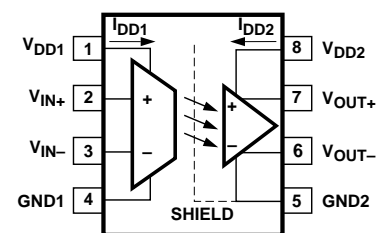

A 0.1 F bypass capacitor must be connected between pins 1 and 4 and between pins 5 and 8.

**CAUTION:** It is advised that normal static precautions be taken in handling and assembly of this component to prevent damage and/or degradation which may be induced by ESD.

## Ordering Information

HCPL-7840#xxx

No option = Standard DIP Package, 50 per tube

300 = Gull Wing Surface Mount Lead Option, 50 per tube

500 = Tape/Reel Package Option (1 K min.), 1000 per reel

Option data sheets available. Contact your Hewlett-Packard sales representative or authorized distributor for more information.

## Package Outline Drawings

### Standard DIP Package

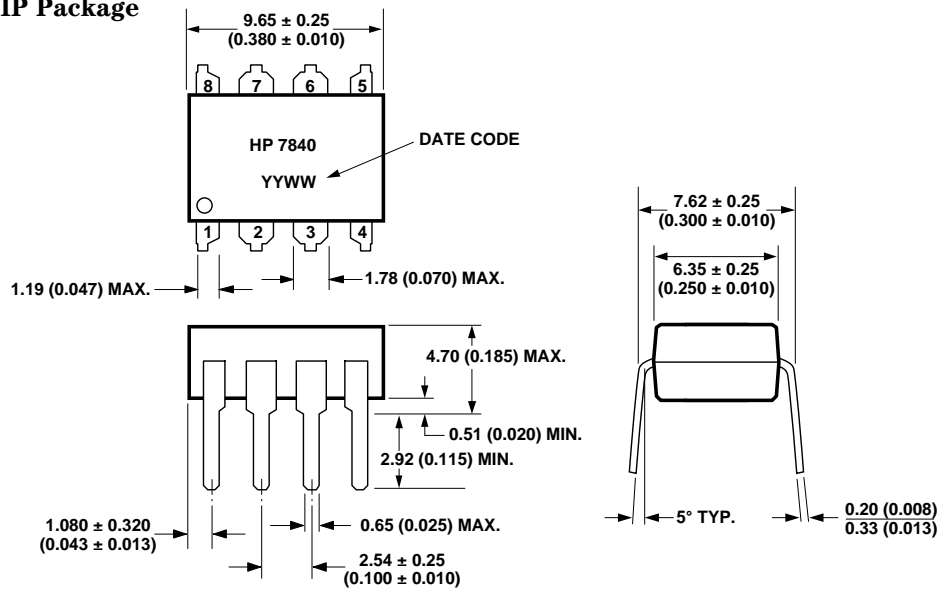

### Gull Wing Surface Mount Option 300

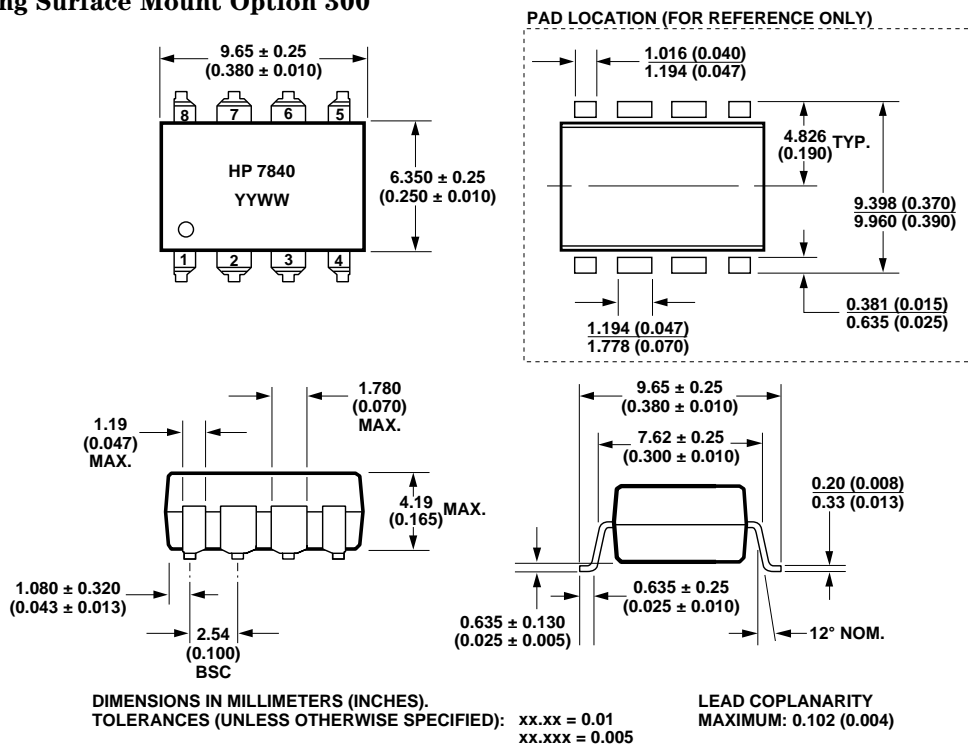

## Maximum Solder Reflow Thermal Profile

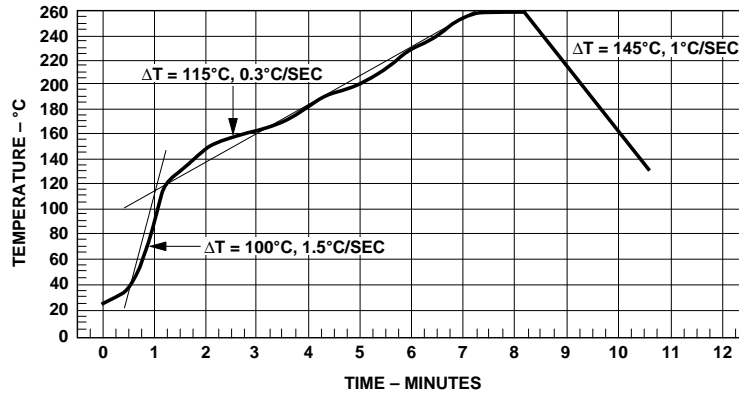

(NOTE: USE OF NON-CHLORINE ACTIVATED FLUXES IS RECOMMENDED.)

## Regulatory Information

The HCPL-7840 has been approved by the following organizations:

UL Recognized under UL 1577, Component Recognition Program, File E55361.

CSA Approved under CSA Component Acceptance Notice #5, File CA 88324.

## Insulation and Safety Related Specifications

Parameter	Symbol	Value	Units	Conditions
Min. External Air Gap (External Clearance)	L(IO1)	7.1	mm	Measured from input terminals to output terminals, shortest distance through air.
Min. External Tracking Path (External Creepage)	L(IO2)	7.4	mm	Measured from input terminals to output terminals, shortest distance path along body.
Min. Internal Plastic Gap (Internal Clearance)		0.08	mm	Through insulation distance, conductor to conductor, usually the direct distance between the photoemitter and photodetector inside the optocoupler cavity.
Tracking Resistance (Comparative Tracking Index)	CTI	200	Volts	DIN IEC 112/VDE 0303 Part 1
Isolation Group		IIIa		Material Group (DIN VDE 0110, 1/89, Table 1)

Option 300 - surface mount classification is Class A in accordance with CECC 00802.

## Absolute Maximum Ratings

Parameter	Symbol	Min.	Max.	Unit	Note
Storage Temperature	$T_S$	-55	125	$^{\circ}\text{C}$	
Ambient Operating Temperature	$T_A$	-40	85	$^{\circ}\text{C}$	
Supply Voltages	$V_{DD1}, V_{DD2}$	0.0	5.5	V	
Steady-State Input Voltage	$V_{IN+}, V_{IN-}$	-2.0	$V_{DD1} + 0.5$	V	1
2 Second Transient Input Voltage		-6.0			
Output Voltages	$V_{OUT+}, V_{OUT-}$	-0.5	$V_{DD2} + 0.5$	V	
Lead Solder Temperature (10 sec., 1.6 mm below seating plane)	$T_{LS}$		260	$^{\circ}\text{C}$	
Solder Reflow Temperature Profile	See Maximum Solder Reflow Thermal Profile Section				

## Recommended Operating Conditions

Parameter	Symbol	Min.	Max.	Unit	Note
Ambient Operating Temperature	$T_A$	-40	85	°C	
Supply Voltages	$V_{DD1}, V_{DD2}$	4.5	5.5	V	
Input Voltage	$V_{IN+}, V_{IN-}$	-200	200	mV	1

## DC Electrical Specifications

All specifications, typicals and figures are at the nominal operating conditions of  $V_{IN+} = 0\text{ V}$ ,  $V_{IN-} = 0\text{ V}$ ,  $T_A = 25^\circ\text{C}$ ,  $V_{DD1} = 5\text{ V}$  and  $V_{DD2} = 5\text{ V}$ , unless otherwise noted.

Parameter	Symbol	Min.	Typ.	Max.	Unit	Test Conditions	Fig.	Note
Input Offset Voltage	$V_{OS}$	-1.2	-0.2	1.0	mV		1	2
		-3.0	-0.2	2.0		$-40^\circ\text{C} \leq T_A \leq 85^\circ\text{C}$ $4.5 \leq (V_{DD1}, V_{DD2}) \leq 5.5\text{ V}$	1,2,3	
Gain	G	7.60	8.00	8.40	V/V	$-200 \leq V_{IN+} \leq 200\text{ mV}$	5	
		7.44	8.00	8.56		$-200 \leq V_{IN+} \leq 200\text{ mV}$ $-40^\circ\text{C} \leq T_A \leq 85^\circ\text{C}$ $4.5 \leq (V_{DD1}, V_{DD2}) \leq 5.5\text{ V}$	5,6,7	
200 mV Nonlinearity	$NL_{200}$		0.1	0.2	%	$-200 \leq V_{IN+} \leq 200\text{ mV}$	5, 8	3
				0.4		$-200 \leq V_{IN+} \leq 200\text{ mV}$ $-40^\circ\text{C} \leq T_A \leq 85^\circ\text{C}$ $4.5 \leq (V_{DD1}, V_{DD2}) \leq 5.5\text{ V}$	5,8,9 10,12	
100 mV Nonlinearity	$NL_{100}$		0.05	0.1		$-100 \leq V_{IN+} \leq 100\text{ mV}$	5, 8	
				0.2		$-100 \leq V_{IN+} \leq 100\text{ mV}$ $-40^\circ\text{C} \leq T_A \leq 85^\circ\text{C}$ $4.5 \leq (V_{DD1}, V_{DD2}) \leq 5.5\text{ V}$	5,8,9 11,12	
Maximum Input Voltage Before Output Clipping	$ V_{IN+} _{MAX}$		320		mV		4	
Average Input Bias Current	$I_{IN}$		-0.57		$\mu\text{A}$		13	4
Average Input Resistance	$R_{IN}$		480		$\text{k}\Omega$			
Input DC Common-Mode Rejection Ratio	$CMRR_{IN}$		69		dB			5
Output Resistance	$R_O$		1		$\Omega$			
Output Low Voltage	$V_{OL}$		1.28		V	$V_{IN+} = 400\text{ mV}$	4	6
Output High Voltage	$V_{OH}$		3.84		V	$V_{IN+} = -400\text{ mV}$		
Output Common-Mode Voltage	$V_{OCM}$	2.20	2.56	2.80	V	$-400 < V_{IN+} < 400\text{ mV}$ $-40^\circ\text{C} \leq T_A \leq 85^\circ\text{C}$		
Input Supply Current	$I_{DD1}$		8.7	15.5	mA	$4.5 \leq (V_{DD1}, V_{DD2}) \leq 5.5\text{ V}$	14	
Output Supply Current	$I_{DD2}$		8.8	14.5	mA		15	
Output Short-Circuit Current	$ I_{OSC} $		11		mA	$V_{OUT} = 0\text{ V}$ or $V_{DD2}$		7

## AC Electrical Specifications

All specifications, typicals and figures are at the nominal operating conditions of  $V_{IN+} = 0\text{ V}$ ,  $V_{IN-} = 0\text{ V}$ ,  $T_A = 25^\circ\text{C}$ ,  $V_{DD1} = 5\text{ V}$  and  $V_{DD2} = 5\text{ V}$ , unless otherwise noted.

Parameter	Symbol	Min.	Typ.	Max.	Unit	Test Conditions	Fig.	Note
Common Mode Rejection	CMR	10	15		kV/ $\mu\text{s}$	$V_{CM} = 1\text{ kV}$ $4.5 \leq (V_{DD1}, V_{DD2}) \leq 5.5\text{ V}$	16	8
Common Mode Rejection Ratio at 60 Hz	CMRR		>140		dB			9
Propagation Delay to 50%	$t_{PD50}$		3.7	6.5	$\mu\text{s}$	$V_{IN+} = 0\text{ to }100\text{ mV step}$ $-40^\circ\text{C} \leq T_A \leq 85^\circ\text{C}$ $4.5 \leq (V_{DD1}, V_{DD2}) \leq 5.5\text{ V}$	17, 18	
Propagation Delay to 90%	$t_{PD90}$		5.7	9.9				
Rise/Fall Time (10-90%)	$t_{R/F}$		3.4	6.6				
Small-Signal Bandwidth (-3 dB)	$f_{-3\text{ dB}}$	50	100		kHz	$-40^\circ\text{C} \leq T_A \leq 85^\circ\text{C}$ $4.5 \leq (V_{DD1}, V_{DD2}) \leq 5.5\text{ V}$	17, 19, 20	
Small-Signal Bandwidth (-45°)	$f_{-45^\circ}$		33					
RMS Input-Referred Noise	$V_N$		0.6		mV <sub>rms</sub>	In recommended application circuit	21, 23	10
Power Supply Rejection	PSR		570		mV <sub>P-P</sub>			11

## Package Characteristics

All specifications, typicals and figures are at the nominal operating conditions of  $V_{IN+} = 0\text{ V}$ ,  $V_{IN-} = 0\text{ V}$ ,  $T_A = 25^\circ\text{C}$ ,  $V_{DD1} = 5\text{ V}$  and  $V_{DD2} = 5\text{ V}$ , unless otherwise noted.

Parameter	Symbol	Min.	Typ.	Max.	Unit	Test Conditions	Fig.	Note
Input-Output Momentary Withstand Voltage*	$V_{ISO}$	2500			V <sub>rms</sub>	$t = 1\text{ min.}$ , $RH \leq 50\%$		12, 13
Input-Output Resistance	$R_{I-O}$		$10^{12}$		$\Omega$	$V_{I-O} = 500\text{ Vdc}$		13
Input-Output Capacitance	$C_{I-O}$		0.6		pF	$f = 1\text{ MHz}$ $V_{I-O} = 0\text{ Vdc}$		

\*The Input-Output Momentary Withstand Voltage is a dielectric voltage rating that should not be interpreted as an input-output continuous voltage rating. For the continuous voltage rating, refer to the VDE 0884 Insulation Characteristics Table (if applicable), your equipment level safety specification, or HP Application Note 1074, "Optocoupler Input-Output Endurance Voltage."

**Notes:**

1. If  $V_{IN}$  is brought above  $V_{DD1} - 2\text{ V}$  with respect to GND1 an internal test mode may be activated. This test mode is not intended for customer use.
2. Exact offset value is dependent on layout of external bypass capacitors. The offset value in the data sheet corresponds to HP's recommended layout (see Figures 25 and 26).
3. Nonlinearity is defined as half of the peak-to-peak output deviation from the best-fit gain line, expressed as a percentage of the full-scale differential output voltage.
4. Because of the switched capacitor nature of the sigma-delta A/D converter, time-averaged values are shown.
5.  $CMRR_{IN}$  is defined as the ratio of the gain for differential inputs applied between pins 2 and 3 to the gain for common mode inputs applied to both pins 2 and 3 with respect to pin 4.
6. When the differential input signal exceeds approximately 320 mV, the outputs will limit at the typical values shown.

7. Short-circuit current is the amount of output current generated when either output is shorted to  $V_{DD2}$  or ground. HP does not recommend operation under these conditions.
8. CMR (also known as IMR or Isolation Mode Rejection) specifies the minimum rate of rise of a common mode noise signal applied across the isolation boundary at which small output perturbations begin to appear. These output perturbations can occur with both the rising and falling edges of the common mode waveform and may be of either polarity. A CMR failure is defined as a perturbation exceeding 200 mV at the output of the recommended application circuit (Figure 23). See applications section for more information on CMR.
9. CMRR is defined as the ratio of differential signal gain (signal applied differentially between pins 2 and 3) to the common mode gain (input pins tied to pin 4 and the signal applied between the input and the output of the isolation amplifier) at 60 Hz, expressed in dB.
10. Output noise comes from two primary sources: chopper noise and sigma-

delta quantization noise. Chopper noise results from chopper stabilization of the output op-amps. It occurs at a specific frequency (typically 500 kHz) and is not attenuated by the on-chip output filter. The on-chip filter does eliminate most, but not all, of the sigma-delta quantization noise. An external filter circuit may be easily added to the external post-amplifier to reduce the total RMS output noise. See applications section for more information.

11. Data sheet value is the amplitude of the transient at the differential output of the HCPL-7840 when a 1  $V_{P-P}$ , 1 MHz square wave with 100 ns rise and fall times (measured at pins 1 and 8) is applied to both  $V_{DD1}$  and  $V_{DD2}$ .
12. In accordance with UL1577, each isolation amplifier is proof tested by applying an insulation test voltage  $\geq 3000 V_{RMS}$  for 1 second (leakage current detection limit  $I_{L-O} \leq 5 \mu A$ ).
13. Device considered a two terminal device: Pins 1, 2, 3 and 4 connected together; pins 5, 6, 7 and 8 connected together.

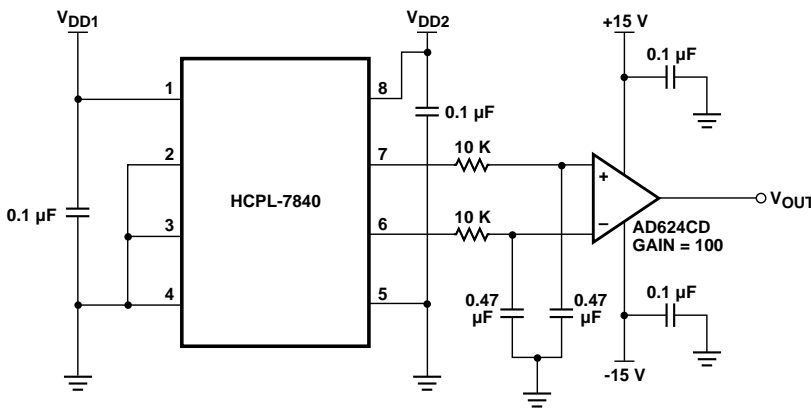

Figure 1. Input Offset Voltage Test Circuit.

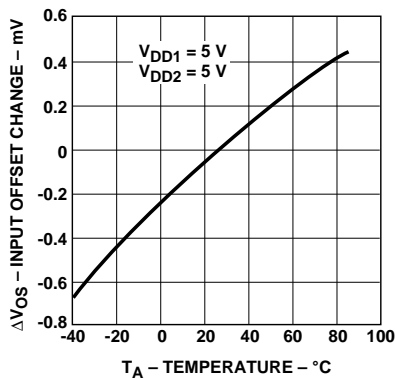

Figure 2. Input Offset Change vs. Temperature.

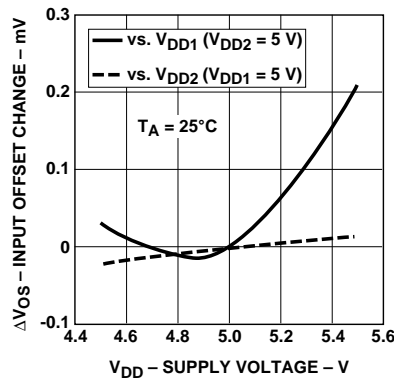

Figure 3. Input Offset Change vs.  $V_{DD1}$  and  $V_{DD2}$ .

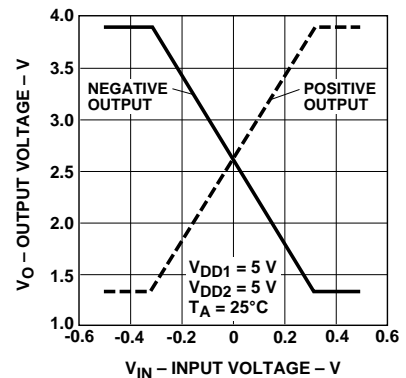

Figure 4. Output Voltages vs. Input Voltage.

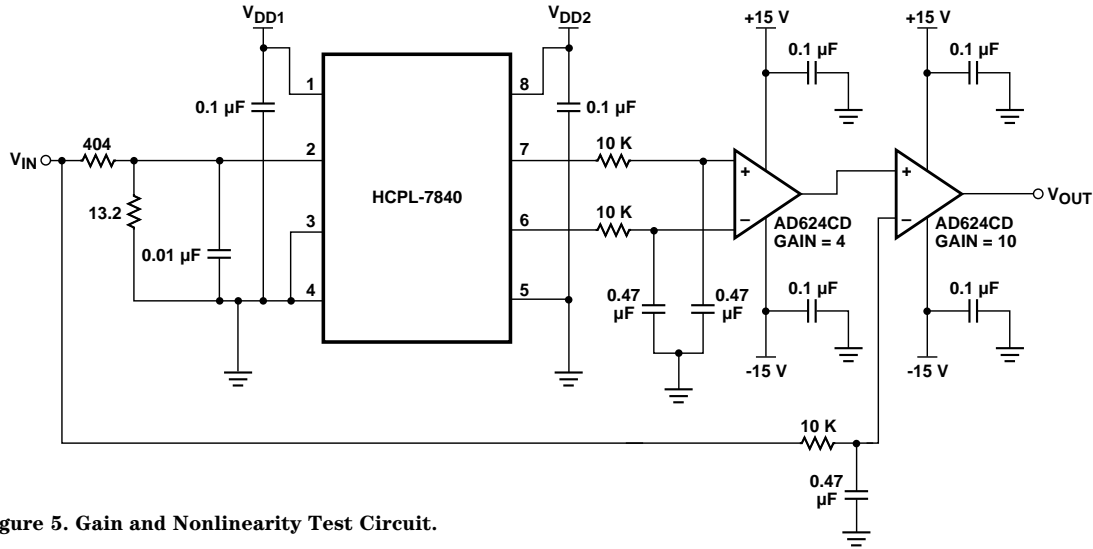

Figure 5. Gain and Nonlinearity Test Circuit.

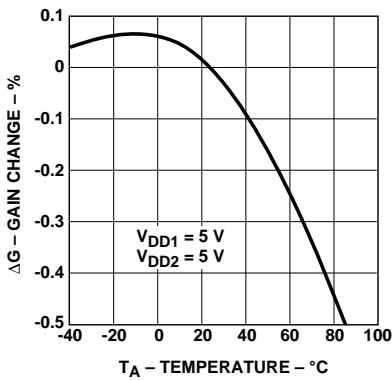

Figure 6. Gain Change vs. Temperature.

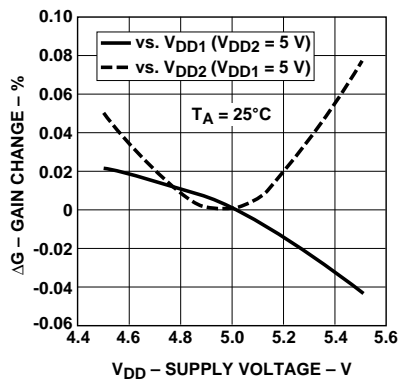

Figure 7. Gain Change vs.  $V_{DD1}$  and  $V_{DD2}$ .

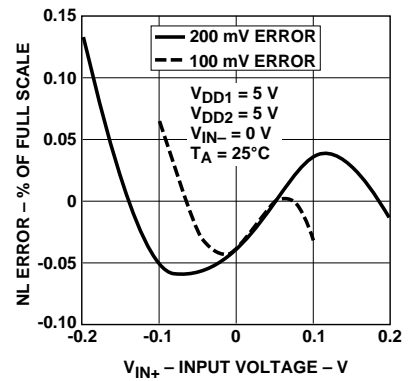

Figure 8. Nonlinearity Error Plot vs. Input Voltage.

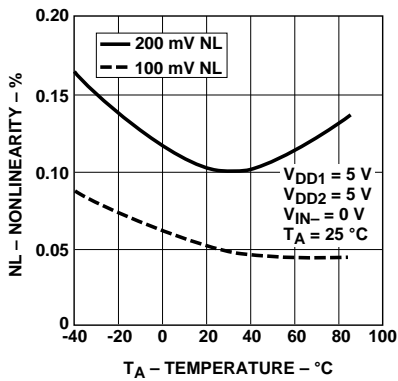

Figure 9. Nonlinearity vs. Temperature.

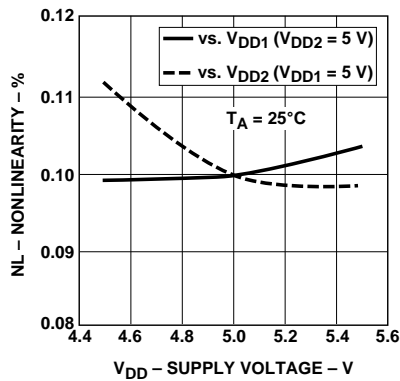

Figure 10. 200 mV Nonlinearity vs.  $V_{DD1}$  and  $V_{DD2}$ .

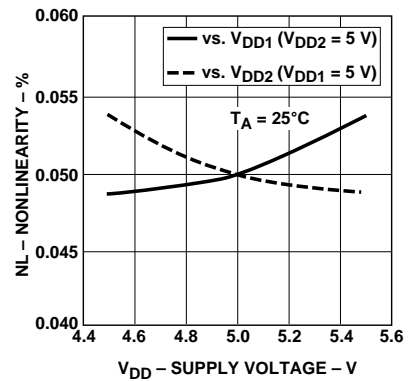

Figure 11. 100 mV Nonlinearity vs.  $V_{DD1}$  and  $V_{DD2}$ .

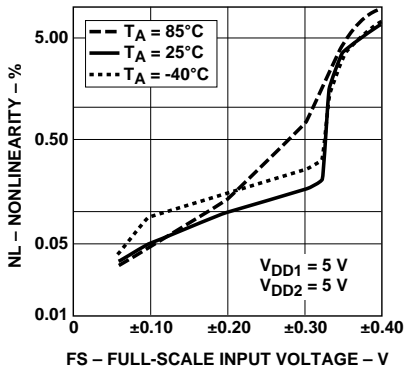

Figure 12. Nonlinearity vs. Full-Scale Input Voltage.

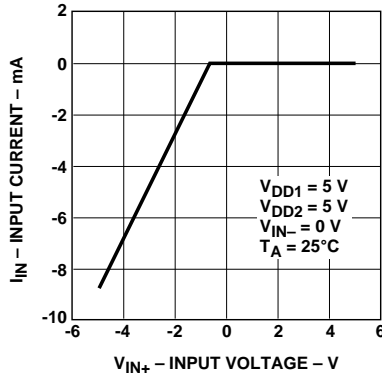

Figure 13. Input Current vs. Input Voltage.

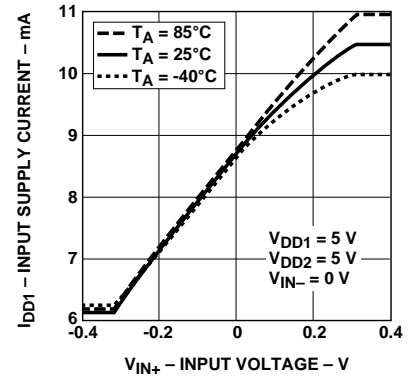

Figure 14. Input Supply Current vs. Input Voltage.

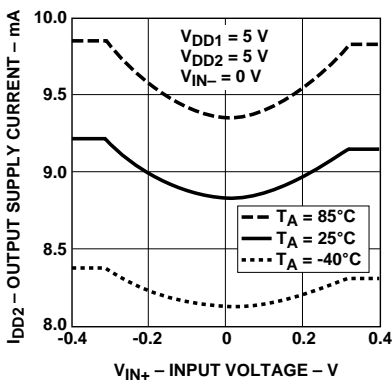

Figure 15. Output Supply Current vs. Input Voltage.

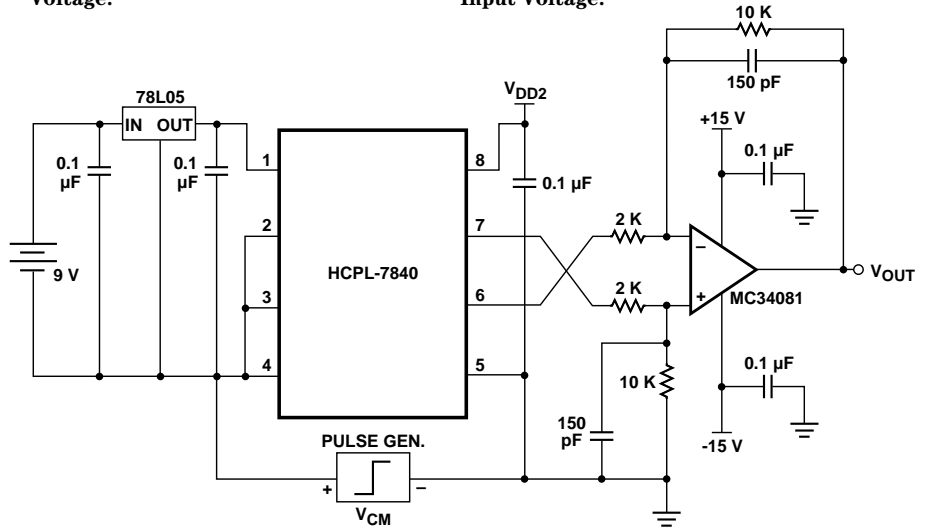
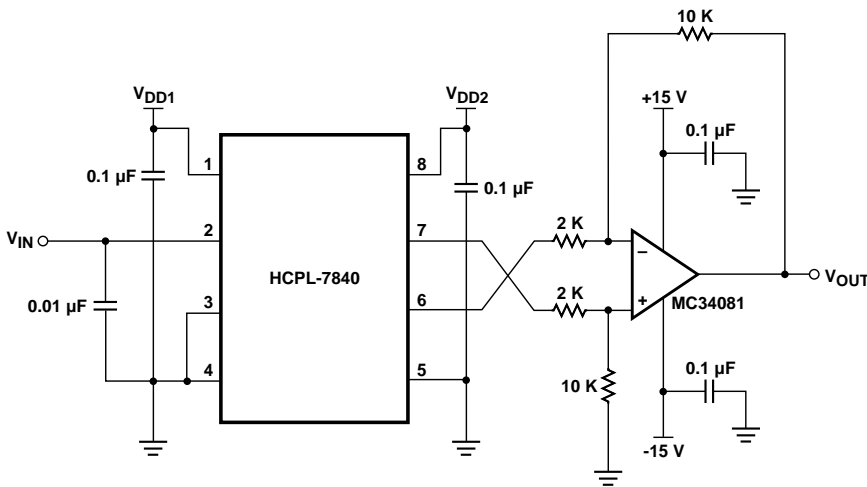

Figure 16. Common Mode Rejection Test Circuit.



$V_{IN}$  IMPEDANCE LESS THAN 10  $\Omega$ .

Figure 17. Propagation Delay, Rise/Fall Time and Bandwidth Test Circuit.

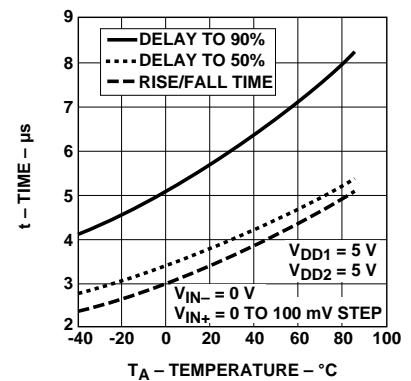

Figure 18. Propagation Delays and Rise/Fall Time vs. Temperature.



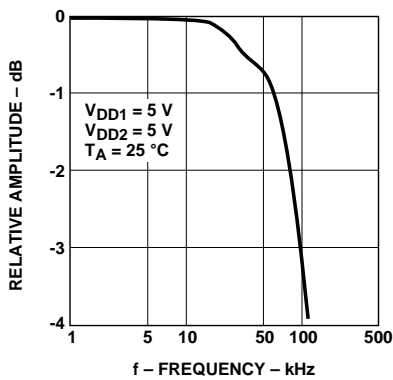

Figure 19. Amplitude Response vs. Frequency.

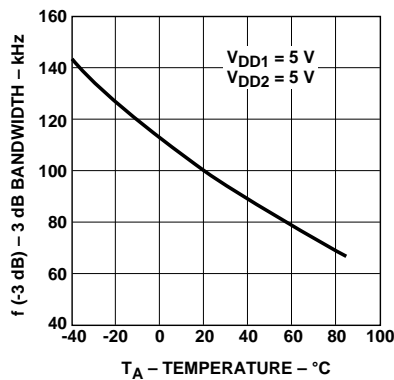

Figure 20. 3 dB Bandwidth vs. Temperature

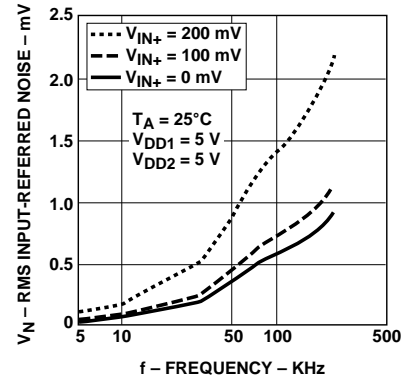

Figure 21. RMS Input-Referred Noise vs. Recommended Application Circuit Bandwidth.

## Applications Information

### Functional Description

Figure 22 shows the primary functional blocks of the HCPL-7840. In operation, the sigma-delta modulator converts the analog input signal into a high-speed serial bit stream. The time average of this bit stream is directly proportional to the input signal. This stream of digital data is encoded and optically transmitted to the detector circuit. The detected signal is decoded and converted back into an analog signal, which is filtered to obtain the final output signal.

### Application Circuit

The recommended application circuit is shown in Figure 23. A floating power supply (which in many applications could be the same supply that is used to drive the high-side power transistor) is regulated to 5 V using a simple three-terminal voltage regulator (U1). The voltage from the current sensing resistor, or shunt ( $R_{sense}$ ), is applied to the input of the HCPL-7840 through an RC anti-aliasing filter ( $R5$ ,  $C3$ ). And

finally, the differential output of the isolation amplifier is converted to a ground-referenced single-ended output voltage with a simple differential amplifier circuit (U3 and associated components). Although the application circuit is relatively simple, a few recommendations should be followed to ensure optimal performance.

### Supplies and Bypassing

As mentioned above, an inexpensive 78L05 three-terminal regulator can be used to reduce the gate-drive power supply voltage to 5 V. To help attenuate high frequency power supply noise or ripple, a resistor or inductor can be used in series with the input of the regulator to form a low-pass filter with the regulator's input bypass capacitor.

As shown in Figure 23, 0.1  $\mu\text{F}$  bypass capacitors ( $C2$ ,  $C4$ ) should be located as close as possible to the input and output power supply pins of the HCPL-7840. The bypass capacitors are

required because of the high-speed digital nature of the signals inside the isolation amplifier. A 0.01  $\mu\text{F}$  bypass capacitor ( $C3$ ) is also recommended at the input pin(s) due to the switched-capacitor nature of the input circuit. The input bypass capacitor should be at least 1000 pF to maintain gain accuracy of the isolation amplifier.

Inductive coupling between the input power-supply bypass capacitor and the input circuit, including the input bypass capacitor and the input leads of the HCPL-7840, can introduce additional DC offset in the circuit. Several steps can be taken to minimize the mutual coupling between the two parts of the circuit, thereby improving the offset performance of the design. Separate the two bypass capacitors  $C2$  and  $C3$  as much as possible (even putting them on opposite sides of the PC board), while keeping the total lead lengths, including traces, of each bypass capacitor less than 20 mm. PC board traces should be made as short as possible and

placed close together or over ground plane to minimize loop area and pickup of stray magnetic fields. Avoid using sockets, as they will typically increase both loop area and inductance. And finally, using capacitors with small body size and orienting them perpendicular to each other on the PC board can also help. For more information concerning this effect, see Application Note 1078, *Designing with Hewlett-Packard Isolation Amplifiers*.

### Shunt Resistor Selection

The current-sensing shunt resistor should have low resistance (to minimize power dissipation), low inductance (to minimize di/dt induced voltage spikes which could adversely affect operation), and reasonable tolerance (to maintain overall circuit accuracy). The value of the shunt should be chosen as a compromise between minimizing power dissipation by making the shunt resistance smaller and improving circuit accuracy by making it larger and utilizing the full input range of the HCPL-7840. Hewlett-Packard recommends four different shunts which can be used to sense average currents in motor drives up to 35 A and 35 hp. Table 1 shows the maximum current and horsepower range for each of the LVR-series shunts from Dale. Even higher currents can be sensed with lower value shunts available from vendors such as Dale, IRC, and Isotek (Isabellenhuetten). When sensing currents large enough to cause significant heating of the shunt, the temperature coefficient of the shunt can introduce nonlinearity due to the signal dependent temperature rise of the shunt. Using a heat sink for the shunt or using a

shunt with a lower tempco can help minimize this effect. The Application Note 1078, *Designing with Hewlett-Packard Isolation Amplifiers*, contains additional information on designing with current shunts.

The recommended method for connecting the isolation amplifier to the shunt resistor is shown in Figure 23. Pin 2 ( $V_{IN+}$ ) is connected to the positive terminal of the shunt resistor, while pin 3 ( $V_{IN-}$ ) is shorted to pin 4 (GND1), with the power-supply return path functioning as the sense line to the negative terminal of the current shunt. This allows a single pair of wires or PC board traces to connect the isolation amplifier circuit to the shunt resistor. In some applications, however, supply currents flowing through the power-supply return path may cause offset or noise problems. In this case, better performance may be obtained by connecting pin 3 to the negative terminal of the shunt resistor separate from the power supply return path. When connected this way, both input pins should be bypassed. Whether two or three wires are used, it is recommended that twisted-pair wire or very close PC board traces be used to connect the current shunt to the isolation amplifier circuit to minimize electromagnetic interference to the sense signal.

The 68  $\Omega$  resistor in series with the input lead forms a low-pass anti-aliasing filter with the input bypass capacitor with a 200 kHz bandwidth. The resistor performs another important function as well; it dampens any ringing which might be present in the circuit formed by the shunt, the

input bypass capacitor, and the wires or traces connecting the two. Undamped ringing of the input circuit near the input sampling frequency can alias into the baseband producing what might appear to be noise at the output of the device. To be effective, the damping resistor should be at least 39  $\Omega$ .

### PC Board Layout

In addition to affecting offset, the layout of the PC board can also affect the common mode rejection (CMR) performance of the isolation amplifier, due primarily to stray capacitive coupling between the input and the output circuits. To obtain optimal CMR performance, the layout of the printed circuit board (PCB) should minimize any stray coupling by maintaining the maximum possible distance between the input and output sides of the circuit and ensuring that any ground plane on the PCB does not pass directly below the HCPL-7840. Using surface mount components can help achieve many of the PCB objectives discussed in the preceding paragraphs. An example through-hole PCB layout illustrating some of the more important layout recommendations is shown in Figures 25 and 26. See Application Note 1078, *Designing with Hewlett-Packard Isolation Amplifiers*, for more information on PCB layout considerations.

### Post-Amplifier Circuit

The recommended application circuit (Figure 23) includes a post-amplifier circuit that serves three functions: to reference the output signal to the desired level (usually ground), to amplify the signal to appropriate levels, and

to help filter output noise. The particular op-amp used in the post-amp is not critical; however, it should have low enough offset and high enough bandwidth and slew rate so that it does not adversely affect circuit performance. The offset of the op-amp should be low relative to the output offset of the HCPL-7840, or less than about 5 mV.

To maintain overall circuit bandwidth, the post-amplifier circuit should have a bandwidth at least twice the minimum bandwidth of the isolation amplifier, or about 200 kHz. To obtain a bandwidth of 200 kHz with a gain of 5, the op-amp should have a gain-bandwidth greater than 1 MHz. The post-amplifier circuit includes a pair of capacitors (C5 and C6) that form a single-pole low-pass filter. These capacitors allow the bandwidth of the post-amp to be adjusted independently of the gain and are useful for reducing the output noise from the isolation amplifier (doubling the capacitor values halves the circuit bandwidth). The component values shown in Figure 23 form a differential amplifier with a gain of 5 and a cutoff frequency of approximately 100 kHz and were chosen as a compromise

between low noise and fast response times. The overall recommended application circuit has a bandwidth of 66 kHz, a rise time of 5.2  $\mu$ s and delay to 90% of 8.5  $\mu$ s.

The gain-setting resistors in the post-amp should have a tolerance of 1% or better to ensure adequate CMRR and gain tolerance for the overall circuit. Resistor networks with even better ratio tolerances can be used which offer better performance, as well as reducing the total component count and board space.

The post-amplifier circuit can be easily modified to allow for single-supply operation. Figure 24 shows a schematic for a post amplifier for use in 5 V single supply applications. One additional resistor is needed and the gain is decreased to 1 to allow circuit operation over the full input voltage range. See Application Note 1078, *Designing with Hewlett-Packard Isolation Amplifiers*, for more information on the post-amplifier circuit.

#### Other Information

As mentioned above, reducing the bandwidth of the post amplifier circuit reduces the amount of output noise. Figure 21 shows

how the output noise changes as a function of the post-amplifier bandwidth. The post-amplifier circuit exhibits a first-order low-pass filter characteristic. For the same filter bandwidth, a higher-order filter can achieve even better attenuation of modulation noise due to the second-order noise shaping of the sigma-delta modulator. For more information on the noise characteristics of the HCPL-7840, see Application Note 1078, *Designing with Hewlett-Packard Isolation Amplifiers*.

The HCPL-7840 can also be used to isolate signals with amplitudes larger than its recommended input range through the use of a resistive voltage divider at its input. The only restrictions are that the impedance of the divider be relatively small (less than 1 K $\Omega$ ) so that the input resistance (480 K $\Omega$ ) and input bias current (0.6 A) do not affect the accuracy of the measurement. An input bypass capacitor is still required, although the 68  $\Omega$  series damping resistor is not (the resistance of the voltage divider provides the same function). The low pass filter formed by the divider resistance and the input bypass capacitor may limit the achievable bandwidth.

**Table 1. Current Shunt Summary**

Shunt Resistor Part Number	Shunt Resistance	Maximum Power Dissipation	Maximum Average Current	Maximum Horsepower Range
LVR-3.05-1%	50 m $\Omega$	3 W	3 A	0.8-3.0 hp
LVR-3.02-1%	20 m $\Omega$	3 W	8 A	2.2-8.0 hp
LVR-3.01-1%	10 m $\Omega$	3 W	15 A	4.1-15 hp
LVR-5.005-1%	5 m $\Omega$	5 W	35 A	9.6-35 hp

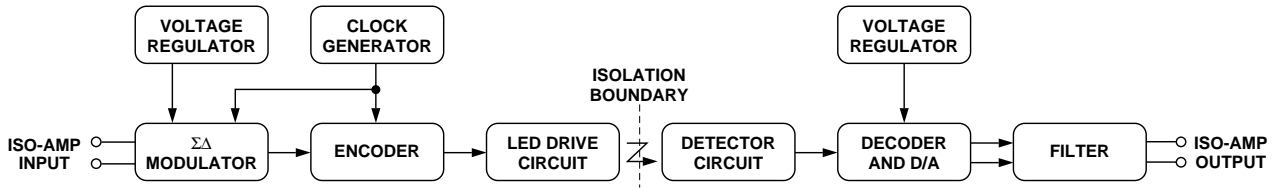

Figure 22. HCPL-7840 Block Diagram.

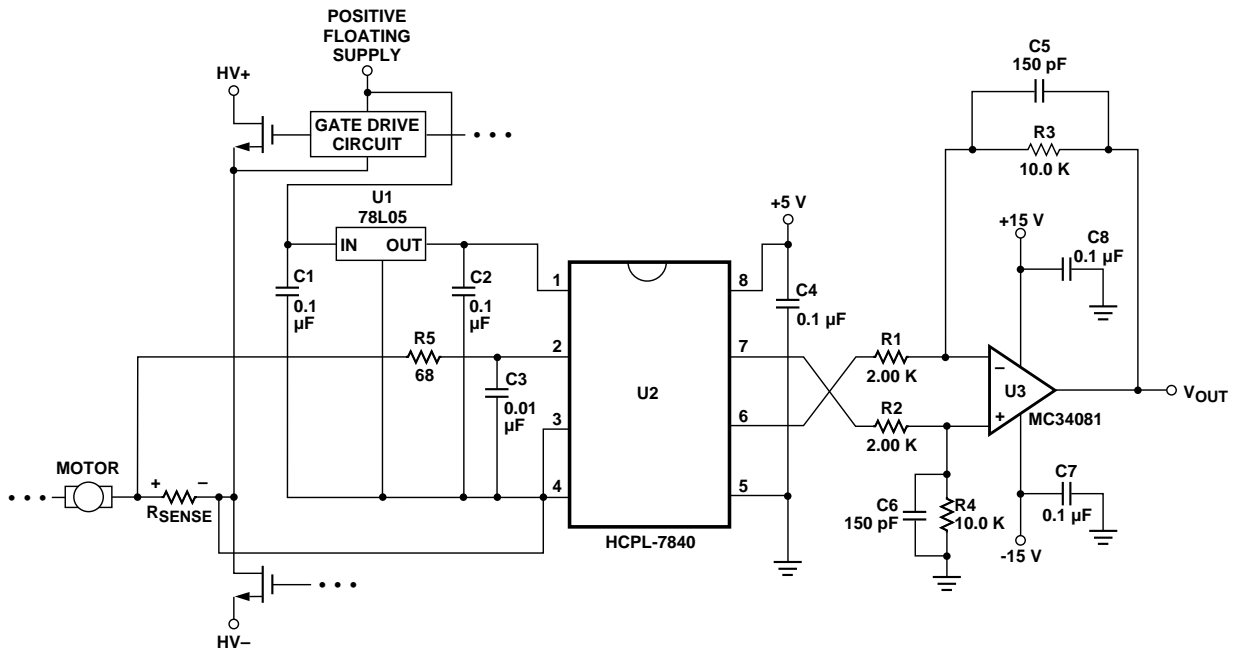

Figure 23. Recommended Application Circuit.

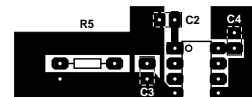

Figure 25. Top Layer of Printed Circuit Board Layout.

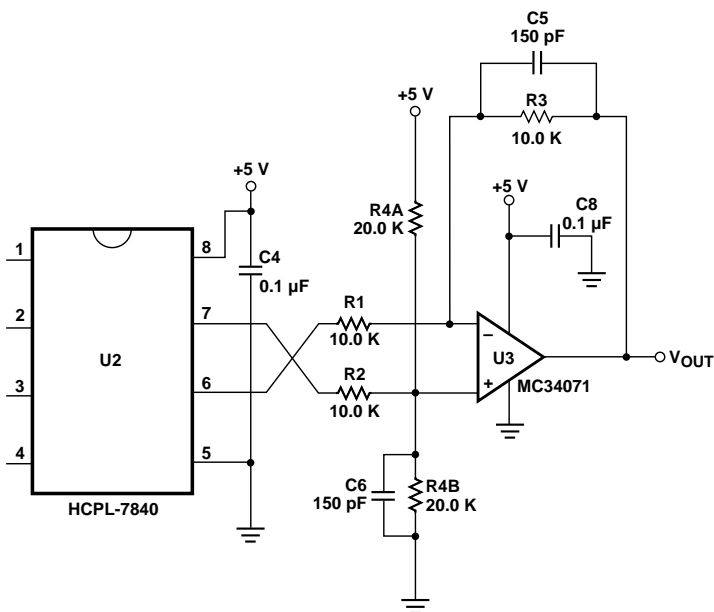

Figure 24. Single-Supply Post-Amplifier Circuit.

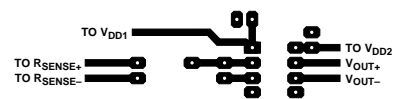

Figure 26. Bottom Layer of Printed Circuit Board Layout.