

IS62C1024L

128K x 8 LOW POWER CMOS STATIC RAM

FEATURES

- High-speed access time: 35, 45, 55, 70 ns
- Low active power: 450 mW (typical)
- Low standby power: 150 μ W (typical) CMOS standby
- Output Enable (\overline{OE}) and two Chip Enable ($\overline{CE1}$ and CE2) inputs for ease in applications
- Fully static operation: no clock or refresh required
- TTL compatible inputs and outputs
- Single 5V ($\pm 10\%$) power supply

DESCRIPTION

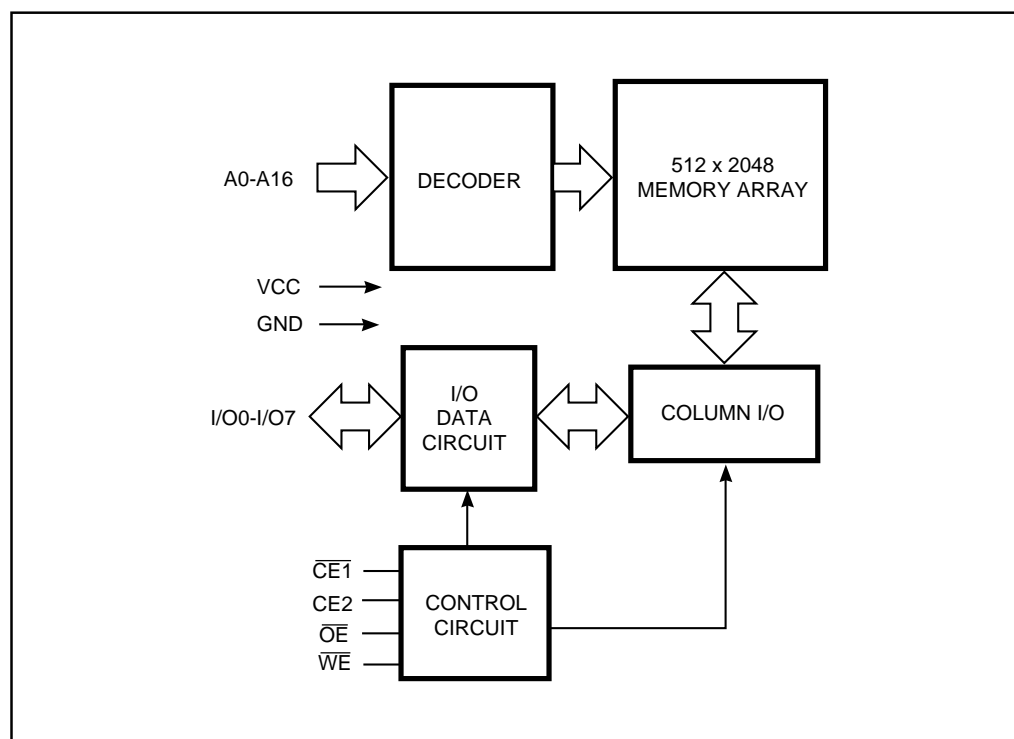
The *ICSI* IS62C1024L is a low power, 131,072-word by 8-bit CMOS static RAM. It is fabricated using *ICSI*'s high-performance CMOS technology. This highly reliable process coupled with innovative circuit design techniques, yields higher performance and low power consumption devices.

When $\overline{CE1}$ is HIGH or CE2 is LOW (deselected), the device assumes a standby mode at which the power dissipation can be reduced by using CMOS input levels.

Easy memory expansion is provided by using two Chip Enable inputs, $\overline{CE1}$ and CE2. The active LOW Write Enable (\overline{WE}) controls both writing and reading of the memory.

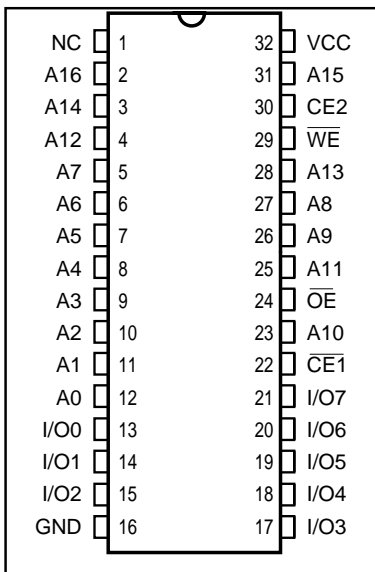
The IS62C1024L is available in 32-pin 600mil DIP, 450mil SOP and 8*20mm TSOP-1 packages.

FUNCTIONAL BLOCK DIAGRAM

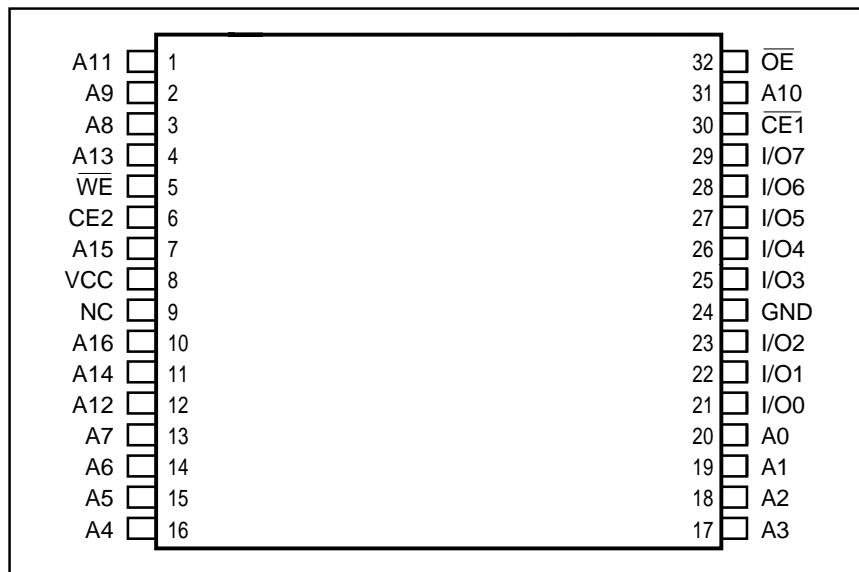


ICSI reserves the right to make changes to its products at any time without notice in order to improve design and supply the best possible product. We assume no responsibility for any errors which may appear in this publication. © Copyright 2000, Integrated Circuit Solution Inc.

PIN CONFIGURATION
32-Pin SOP and DIP



PIN CONFIGURATION
32-Pin 8x20mm TSOP-1



PIN DESCRIPTIONS

A0-A16	Address Inputs
$\overline{CE1}$	Chip Enable 1 Input
CE2	Chip Enable 2 Input
\overline{OE}	Output Enable Input
\overline{WE}	Write Enable Input
I/O0-I/O7	Input/Output
Vcc	Power
GND	Ground

OPERATING RANGE

Range	Ambient Temperature	Vcc
Commercial	0°C to +70°C	5V ± 10%
Industrial	-40°C to +85°C	5V ± 10%

TRUTH TABLE

Mode	\overline{WE}	$\overline{CE1}$	CE2	\overline{OE}	I/O Operation	Vcc Current
Not Selected	X	H	X	X	High-Z	Isb1, Isb2
(Power-down)	X	X	L	X	High-Z	Isb1, Isb2
Output Disabled	H	L	H	H	High-Z	Icc
Read	H	L	H	L	DOUT	Icc
Write	L	L	H	X	DIN	Icc

IS62C1024L

ABSOLUTE MAXIMUM RATINGS⁽¹⁾

Symbol	Parameter	Value	Unit
V _{TERM}	Terminal Voltage with Respect to GND	-0.5 to +7.0	V
T _{BIAS}	Temperature Under Bias	-45 to +85	°C
T _{STG}	Storage Temperature	-65 to +150	°C
P _T	Power Dissipation	1.5	W
I _{OUT}	DC Output Current (LOW)	20	mA

Notes:

1. Stress greater than those listed under ABSOLUTE MAXIMUM RATINGS may cause permanent damage to the device. This is a stress rating only and functional operation of the device at these or any other conditions above those indicated in the operational sections of this specification is not implied. Exposure to absolute maximum rating conditions for extended periods may affect reliability.

CAPACITANCE^(1,2)

Symbol	Parameter	Conditions	Max.	Unit
C _{IN}	Input Capacitance	V _{IN} = 0V	6	pF
C _{OUT}	Output Capacitance	V _{OUT} = 0V	8	pF

Notes:

1. Tested initially and after any design or process changes that may affect these parameters.
2. Test conditions: T_A = 25°C, f = 1 MHz, V_{CC} = 5.0V.

DC ELECTRICAL CHARACTERISTICS (Over Operating Range)

Symbol	Parameter	Test Conditions	Min.	Max.	Unit
V _{OH}	Output HIGH Voltage	V _{CC} = Min., I _{OH} = -1.0 mA	2.4	—	V
V _{OL}	Output LOW Voltage	V _{CC} = Min., I _{OL} = 2.1 mA	—	0.4	V
V _{IH}	Input HIGH Voltage		2.2	V _{CC} + 0.5	V
V _{IL}	Input LOW Voltage ⁽¹⁾		-0.3	0.8	V
I _{LI}	Input Leakage	GND ≤ V _{IN} ≤ V _{CC}	Com. Ind.	-2 10	2 μA
I _{LO}	Output Leakage	GND ≤ V _{OUT} ≤ V _{CC}	Com. Ind.	-2 10	2 μA

Notes:

1. V_{IL} = -3.0V for pulse width less than 10 ns.

POWER SUPPLY CHARACTERISTICS⁽¹⁾ (Over Operating Range)

Symbol	Parameter	Test Conditions	-35 ns		-45 ns		-55 ns		-70 ns		Unit	
			Min.	Max.	Min.	Max.	Min.	Max.	Min.	Max.		
I _{CC}	V _{CC} Dynamic Operating Supply Current	V _{CC} = Max., $\overline{CE} = V_{IL}$ I _{OUT} = 0 mA, f = f _{MAX}	Com.	—	100	—	90	—	80	—	70	mA
			Ind.	—	110	—	100	—	90	—	80	
I _{SB1}	TTL Standby Current (TTL Inputs)	V _{CC} = Max., V _{IN} = V _{IH} or V _{IL} , $\overline{CE1} \geq V_{IH}$, or CE2 ≤ V _{IL} , f = 0	Com.	—	10	—	10	—	10	—	10	mA
			Ind.	—	15	—	15	—	15	—	15	
I _{SB2}	CMOS Standby Current (CMOS Inputs)	V _{CC} = Max., $\overline{CE1} \leq V_{CC} - 0.2V$, CE2 ≤ 0.2V, V _{IN} > V _{CC} - 0.2V, or V _{IN} ≤ 0.2V, f = 0	Com.	—	500	—	500	—	500	—	500	μA
			Ind.	—	750	—	750	—	750	—	750	

Note:

1. At f = f_{MAX}, address and data inputs are cycling at the maximum frequency, f = 0 means no input lines change.

READ CYCLE SWITCHING CHARACTERISTICS⁽¹⁾ (Over Operating Range)

Symbol	Parameter	-35		-45		-55		-70		Unit
		Min.	Max.	Min.	Max.	Min.	Max.	Min.	Max.	
t_{RC}	Read Cycle Time	35	—	45	—	55	—	70	—	ns
t_{AA}	Address Access Time	—	35	—	45	—	55	—	70	ns
t_{OHA}	Output Hold Time	3	—	3	—	3	—	3	—	ns
t_{ACE1}	$\overline{CE1}$ Access Time	—	35	—	45	—	55	—	70	ns
t_{ACE2}	CE2 Access Time	—	35	—	45	—	55	—	70	ns
t_{DOE}	\overline{OE} Access Time	—	10	—	20	—	25	—	35	ns
$t_{LZOE}^{(2)}$	\overline{OE} to Low-Z Output	0	—	0	—	0	—	0	—	ns
$t_{HZOE}^{(2)}$	\overline{OE} to High-Z Output	0	10	0	15	0	20	0	25	ns
$t_{LZCE1}^{(2)}$	$\overline{CE1}$ to Low-Z Output	3	—	5	—	7	—	10	—	ns
$t_{LZCE2}^{(2)}$	CE2 to Low-Z Output	3	—	5	—	7	—	10	—	ns
$t_{HZCE}^{(2)}$	$\overline{CE1}$ or CE2 to High-Z Output	0	10	0	15	0	20	0	25	ns

Notes:

1. Test conditions assume signal transition times of 5 ns or less, timing reference levels of 1.5V, input pulse levels of 0 to 3.0V and output loading specified in Figure 1a.
2. Tested with the load in Figure 1b. Transition is measured ± 500 mV from steady-state voltage. Not 100% tested.

AC TEST CONDITIONS

Parameter	Unit
Input Pulse Level	0V to 3.0V
Input Rise and Fall Times	5 ns
Input and Output Timing and Reference Level	1.5V
Output Load	See Figures 1a and 1b

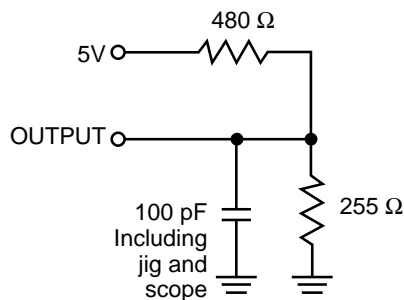
AC TEST LOADS


Figure 1a.

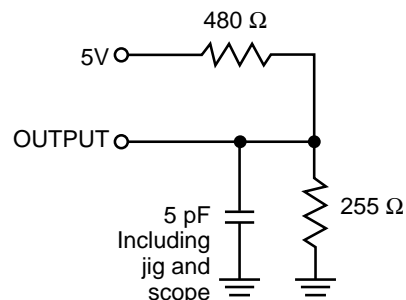
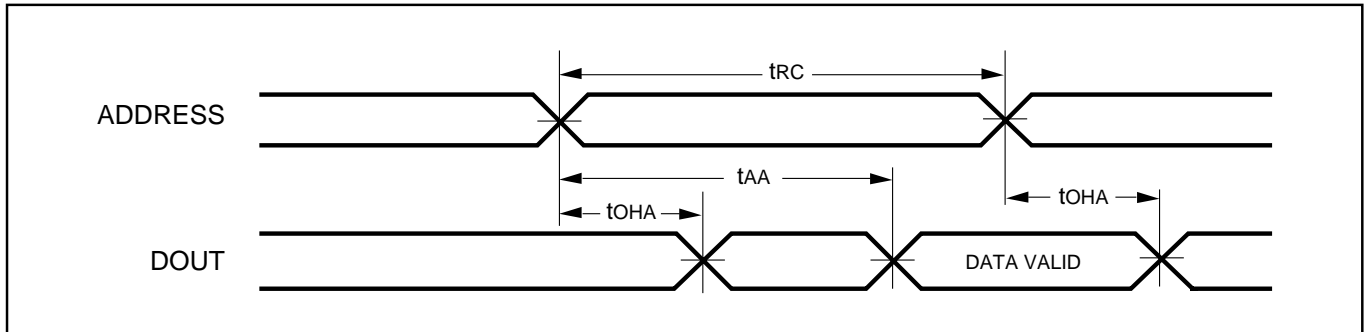


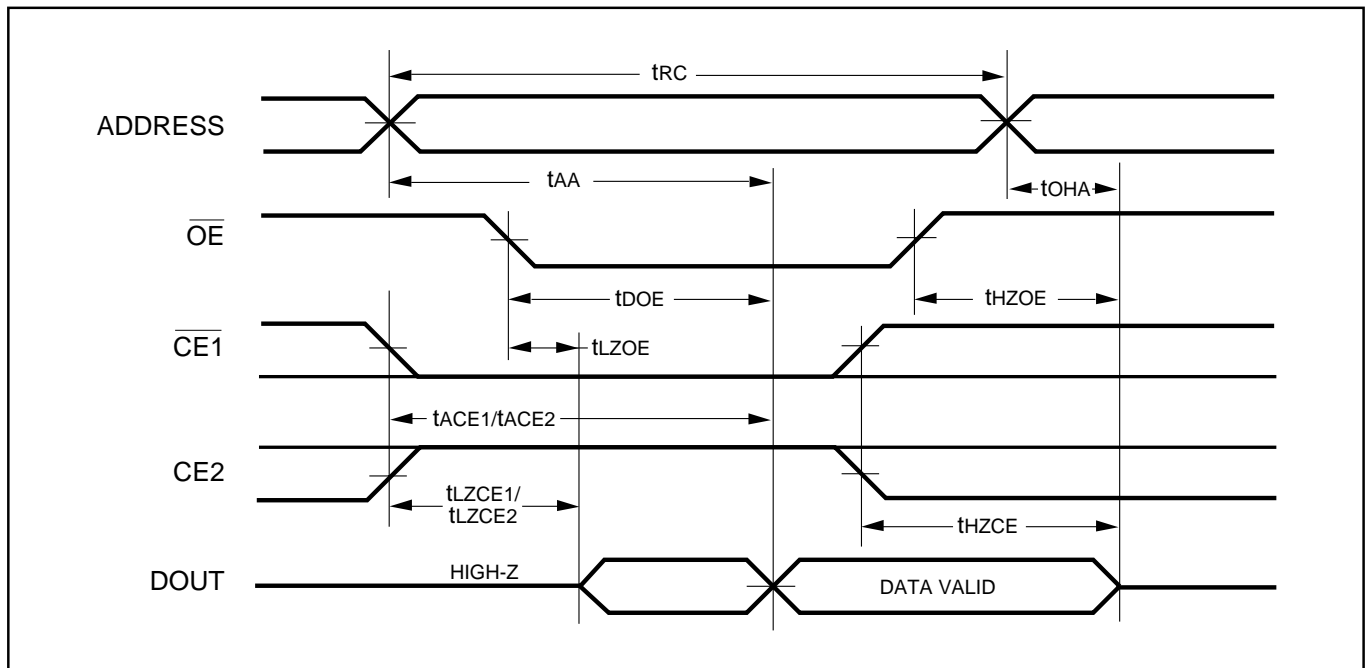
Figure 1b.

AC WAVEFORMS

READ CYCLE NO. 1^(1,2)



READ CYCLE NO. 2^(1,3)



Notes:

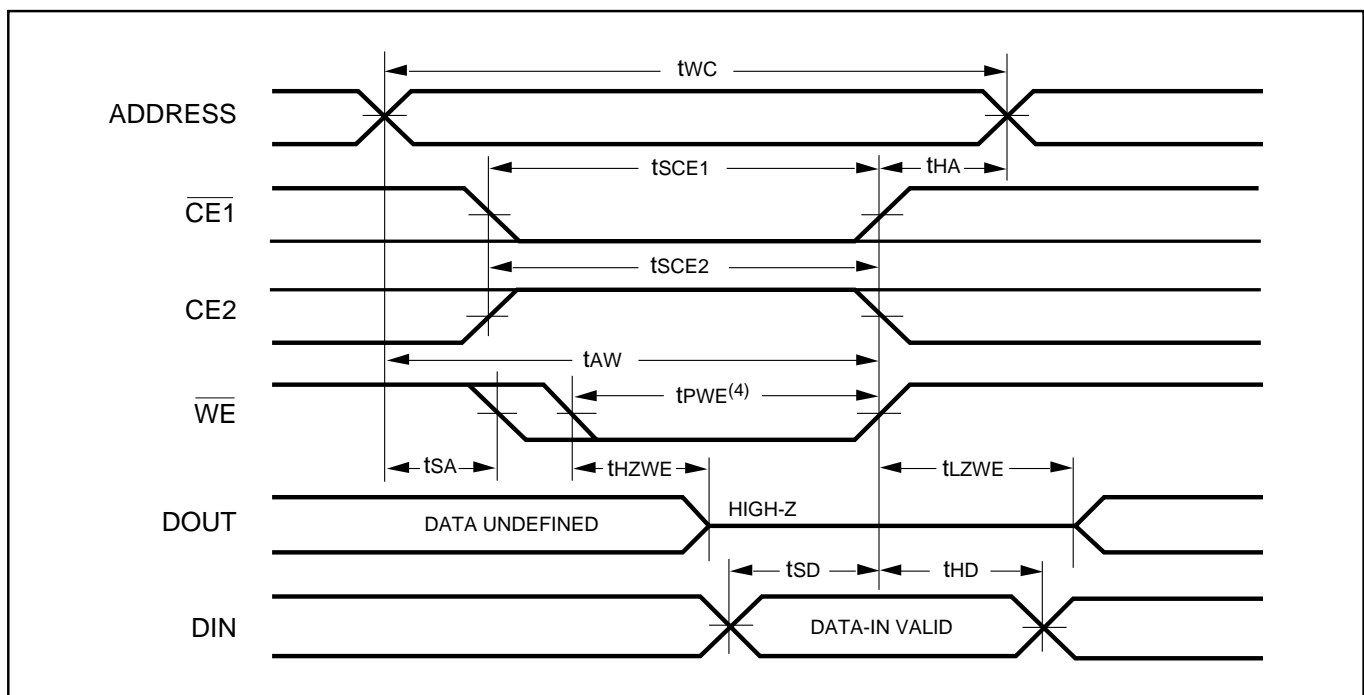
1. \overline{WE} is HIGH for a Read Cycle.
2. The device is continuously selected. \overline{OE} , $\overline{CE1} = V_{IL}$, $CE2 = V_{IH}$.
3. Address is valid prior to or coincident with $\overline{CE1}$ LOW and $CE2$ HIGH transitions.

WRITE CYCLE SWITCHING CHARACTERISTICS^(1,3) (Over Operating Range, Standard and Low Power)

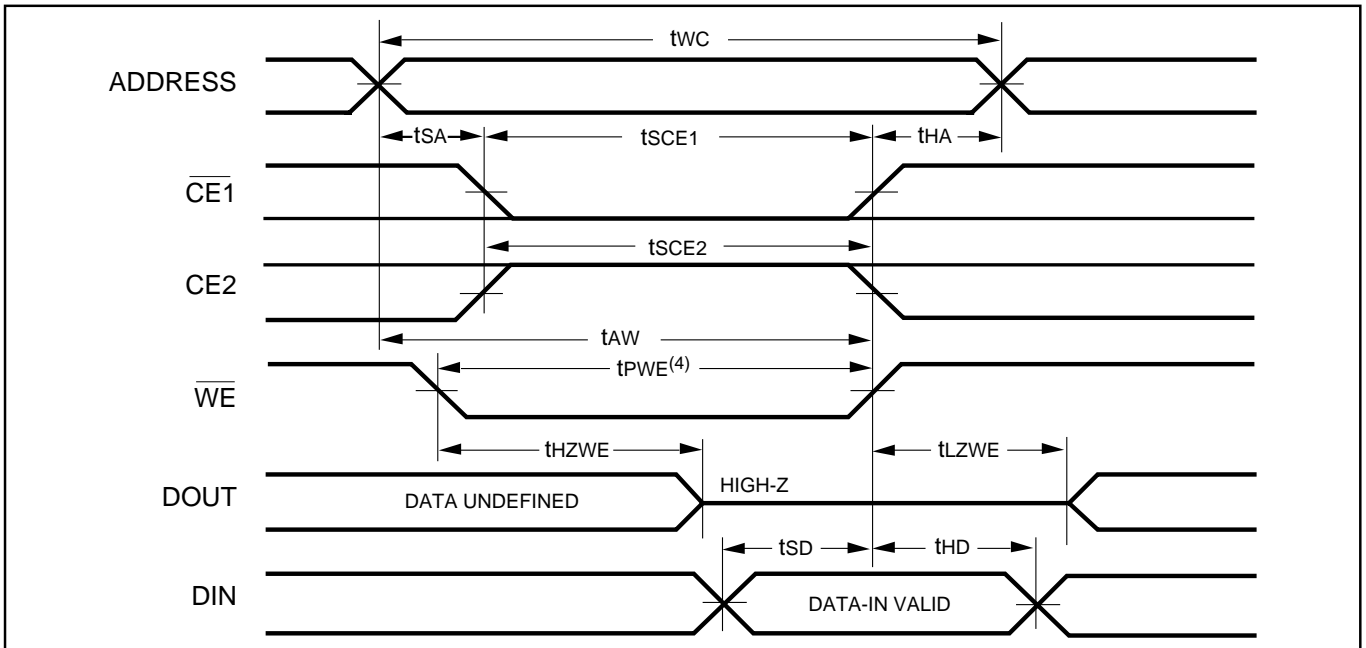
Symbol	Parameter	-35		-45		-55		-70		Unit
		Min.	Max.	Min.	Max.	Min.	Max.	Min.	Max.	
t _{WC}	Write Cycle Time	35	—	45	—	55	—	70	—	ns
t _{SCE1}	$\overline{CE1}$ to Write End	25	—	35	—	50	—	60	—	ns
t _{SCE2}	CE2 to Write End	25	—	35	—	50	—	60	—	ns
t _{AW}	Address Setup Time to Write End	25	—	35	—	45	—	60	—	ns
t _{HA}	Address Hold from Write End	0	—	0	—	0	—	0	—	ns
t _{SA}	Address Setup Time	0	—	0	—	0	—	0	—	ns
t _{PWE⁽⁴⁾}	\overline{WE} Pulse Width	25	—	35	—	40	—	50	—	ns
t _{SD}	Data Setup to Write End	20	—	25	—	25	—	30	—	ns
t _{HD}	Data Hold from Write End	0	—	0	—	0	—	0	—	ns
t _{HZWE⁽²⁾}	\overline{WE} LOW to High-Z Output	—	10	—	15	—	20	—	25	ns
t _{LZWE⁽²⁾}	\overline{WE} HIGH to Low-Z Output	3	—	5	—	5	—	5	—	ns

Notes:

1. Test conditions assume signal transition times of 5 ns or less, timing reference levels of 1.5V, input pulse levels of 0 to 3.0V and output loading specified in Figure 1a.
2. Tested with the load in Figure 1b. Transition is measured ± 500 mV from steady-state voltage. Not 100% tested.
3. The internal write time is defined by the overlap of CE1 LOW, CE2 HIGH and WE LOW. All signals must be in valid states to initiate a Write, but any one can go inactive to terminate the Write. The Data Input Setup and Hold timing are referenced to the rising or falling edge of the signal that terminates the Write.
4. Tested with \overline{OE} HIGH.

AC WAVEFORMS
WRITE CYCLE NO. 1 (\overline{WE} Controlled)^(1,2)


WRITE CYCLE NO. 2 ($\overline{CE1}$, CE2 Controlled)^(1,2)



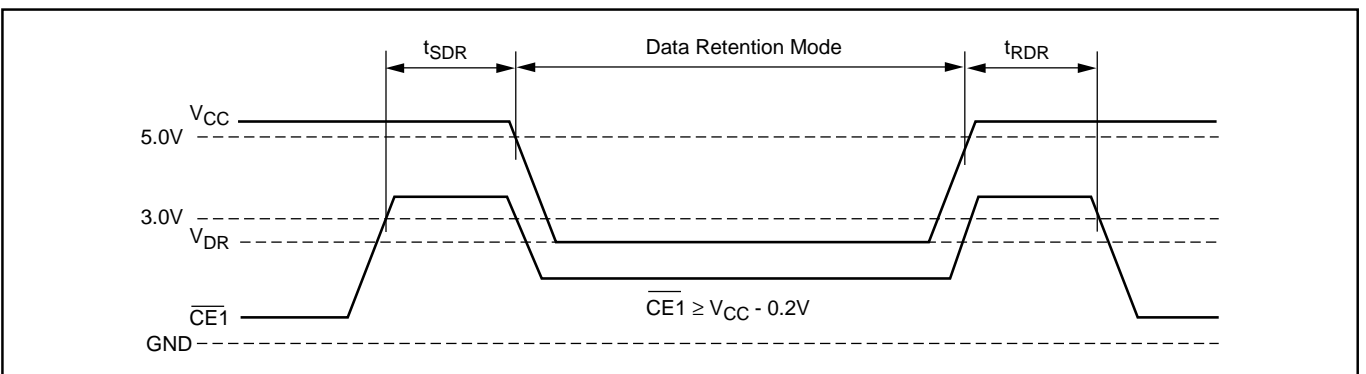
Notes:

1. The internal write time is defined by the overlap of $\overline{CE1}$ LOW, CE2 HIGH and \overline{WE} LOW. All signals must be in valid states to initiate a Write, but any one can go inactive to terminate the Write. The Data Input Setup and Hold timing are referenced to the rising or falling edge of the signal that terminates the Write.
2. I/O will assume the High-Z state if $\overline{OE} = V_{IH}$.

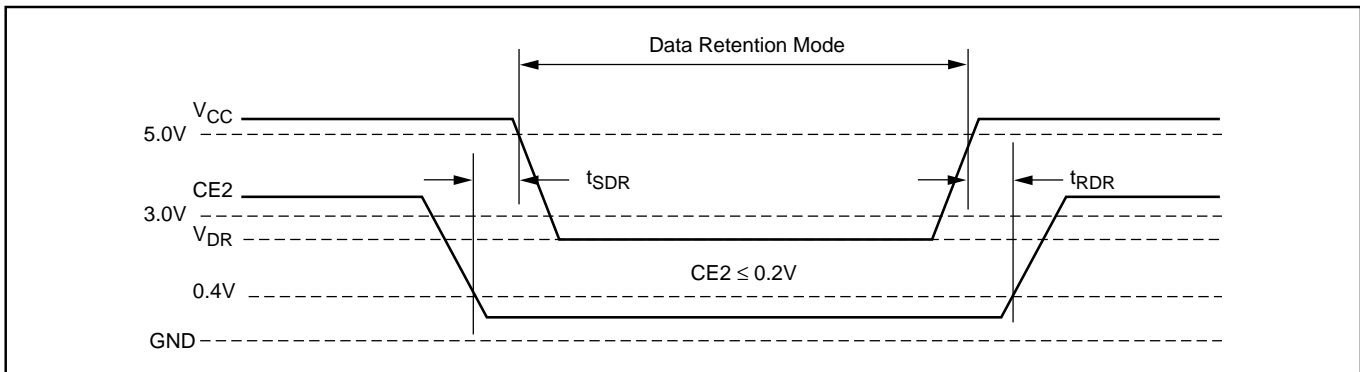
DATA RETENTION SWITCHING CHARACTERISTICS

Symbol	Parameter	Test Condition	Min.	Max.	Unit
V_{DR}	Vcc for Data Retention	See Data Retention Waveform	2.0	5.5	V
I_{DR}	Data Retention Current	$V_{CC} = 3.0V, \overline{CE1} \geq V_{CC} - 0.2V$	Com. Ind.	— 250 400	μA
t_{SDR}	Data Retention Setup Time	See Data Retention Waveform	0	—	ns
t_{RDR}	Recovery Time	See Data Retention Waveform	t_{rc}	—	ns

DATA RETENTION WAVEFORM ($\overline{CE1}$ Controlled)



DATA RETENTION WAVEFORM (CE2 Controlled)



ORDERING INFORMATION

Commercial Range: 0°C to +70°C

Speed (ns)	Order Part No.	Package
35	IS62C1024L-35W	600mil DIP
35	IS62C1024L-35Q	450mil SOP
35	IS62C1024L-35T	8*20mm TSOP-1
45	IS62C1024L-45W	600mil DIP
45	IS62C1024L-45Q	450mil SOP
45	IS62C1024L-45T	8*20mm TSOP-1
55	IS62C1024L-55W	600mil DIP
55	IS62C1024L-55Q	450mil SOP
55	IS62C1024L-55T	8*20mm TSOP-1
70	IS62C1024L-70W	600mil DIP
70	IS62C1024L-70Q	450mil SOP
70	IS62C1024L-70T	8*20mm TSOP-1

ORDERING INFORMATION

Industrial Range: -40°C to +85°C

Speed (ns)	Order Part No.	Package
35	IS62C1024L-35WI	600mil DIP
35	IS62C1024L-35QI	450mil SOP
35	IS62C1024L-35TI	8*20mm TSOP-1
45	IS62C1024L-45WI	600mil DIP
45	IS62C1024L-45QI	450mil SOP
45	IS62C1024L-45TI	8*20mm TSOP-1
55	IS62C1024L-55WI	600mil DIP
55	IS62C1024L-55QI	450mil SOP
55	IS62C1024L-55TI	8*20mm TSOP-1
70	IS62C1024L-70WI	600mil DIP
70	IS62C1024L-70QI	450mil SOP
70	IS62C1024L-70TI	8*20mm TSOP-1



Integrated Circuit Solution Inc.

HEADQUARTER:

NO.2, TECHNOLOGY RD. V, SCIENCE-BASED INDUSTRIAL PARK,
HSIN-CHU, TAIWAN, R.O.C.

TEL: 886-3-5780333

Fax: 886-3-5783000

BRANCH OFFICE:

7F, NO. 106, SEC. 1, HSIN-TAI 5TH ROAD,
HSICHIH TAIPEI COUNTY, TAIWAN, R.O.C.

TEL: 886-2-26962140

FAX: 886-2-26962252

<http://www.icsi.com.tw>