



Frequency Generator & Integrated Buffers for PENTIUM/Pro™

General Description

The ICS9148-26 generates all clocks required for high speed RISC or CISC microprocessor systems such as Intel PentiumPro or Cyrix. Eight different reference frequency multiplying factors are externally selectable with smooth frequency transitions.

Features include two CPU, six PCI and fourteen SDRAM clocks. Two reference outputs are available equal to the crystal frequency. Plus the IOAPIC output powered by VDDL1. One 48 MHz for USB, and one 24 MHz clock for Super IO. Spread Spectrum built in at $\pm 0.5\%$ or $\pm 1.5\%$ modulation to reduce the EMI. Serial programming I²C interface allows changing functions, stop clock programing and Frequency selection. Additionally, the device meets the Pentium power-up stabilization, which requires that CPU and PCI clocks be stable within 2ms after power-up. It is not recommended to use I/O dual function pin for the slots (ISA, PIC, CPU, DIMM). The add on card might have a pull up or pull down.

High drive PCICLK and SDRAM outputs typically provide greater than 1 V/ns slew rate into 30pF loads. CPUCLK outputs typically provide better than 1V/ns slew rate into 20pF loads while maintaining 50 \pm 5% duty cycle. The REF and 24 and 48 MHz clock outputs typically provide better than 0.5V/ns slew rates into 20pF.

Block Diagram

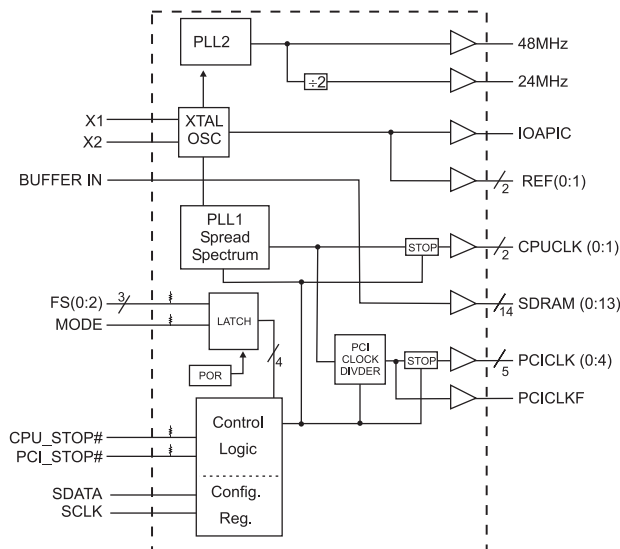

Features

- 3.3V outputs: SDRAM, PCI, REF, 48/24MHz
- 2.5V outputs: CPU, IOAPIC
- 20 ohm CPU clock output impedance
- 20 ohm PCI clock output impedance
- Skew from CPU (earlier) to PCI clock - 1 to 4 ns, center 2.2 ns.
- No external load cap for C_L=18pF crystals
- ± 250 ps CPU, PCI clock skew
- 250ps (cycle to cycle) CPU jitter @ 66.66MHz
- Smooth frequency switch, with selections from 50 to 133 MHz CPU.
- I²C interface for programming
- 2ms power up clock stable time
- Clock duty cycle 45-55%.
- 48 pin 300 mil SSOP package
- 3.3V operation, 5V tolerant inputs (with series R)
- <6ns propagation delay SDRAM form Buffer Input

Pin Configuration

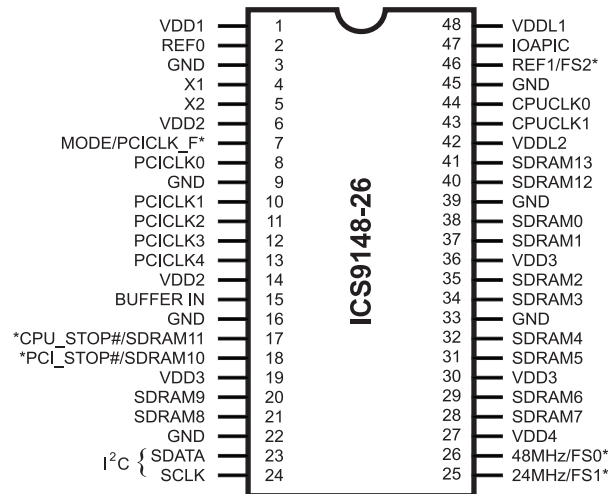

48-Pin SSOP

* Internal Pull-up Resistor of 240K to 3.3V on indicated inputs

Power Groups

- VDD1 = REF (0:1), X1, X2
- VDD2 = PCICLK_F, PCICLK(0:4)
- VDD3 = SDRAM(0:13), supply for PLL core
- VDD4 = 24MHz, 48MHz
- VDDL1 = IOAPIC
- VDDL2 = CPUCLK(0:1)

Pentium is a trademark of Intel Corporation
I²C is a trademark of Philips Corporation



Pin Descriptions

| PIN NUMBER | PIN NAME | TYPE | DESCRIPTION |
|--|------------------------|------|--|
| 1 | VDD1 | PWR | Ref (0:2), XTAL power supply, nominal 3.3V |
| 2 | REF0 | OUT | 14.318 Mhz reference clock.This REF output is the STRONGER buffer for ISA BUS loads |
| 3,9,16,22,33,39,45 | GND | PWR | Ground |
| 4 | X1 | IN | Crystal input, has internal load cap (36pF) and feedback resistor from X2 |
| 5 | X2 | OUT | Crystal output, nominally 14.318MHz. Has internal load cap (36pF) |
| 6,14 | VDD2 | PWR | Supply for PCICLK_F and PCICLK (0:5), nominal 3.3V |
| 7 | PCICLK_F | OUT | Free running PCI clock |
| | MODE ^{1, 2} | IN | Pin 17, pin 18 function select pin, 1=Desktop Mode, 0=Mobile Mode. Latched Input. |
| 8 | PCICLK0 | OUT | PCI clock output. |
| 10, 11, 12, 13 | PCICLK(1:4) | OUT | PCI clock outputs. |
| 15 | BUFFER IN | IN | Input to Fanout Buffers for SDRAM outputs. |
| 18 | PCI_STOP# ¹ | IN | Halts PCICLK(0:4) clocks at logic 0 level, when input low (In mobile mode, MODE=0) |
| 17, 18, 20, 21, 28, 29, 31, 32, 34, 35,37,38,40,41 | SDRAM (0:13) | OUT | (Pins 17, 18 SDRAM output only if MODE=High) SDRAM clock outputs, Fanout Buffer outputs from BUFFER IN pin (controlled by chipset). |
| 19,30,36 | VDD3 | PWR | Supply for SDRAM (0:13) and CPU PLL Core, nominal 3.3V. |
| 23 | SDATA | IN | Data input for I ² C serial input, 5V tolerant input |
| 24 | SCLK | IN | Clock input of I ² C input, 5V tolerant input |
| 25 | 24MHz | OUT | 24MHz output clock |
| | FS1 ^{1, 2} | IN | Frequency select pin. Latched Input. |
| 26 | 48MHz | OUT | 48MHz output clock |
| | FS0 ^{1, 2} | IN | Frequency select pin. Latched Input |
| 27 | VDD4 | PWR | Power for 24 & 48MHz output buffers and fixed PLL core. |
| 43, 44 | CPUCLK(0:1) | OUT | CPU clock outputs, powered by VDDL2. Low if CPU_STOP#=Low |
| 42 | VDDL2 | PWR | Supply for CPU (0:1), either 2.5V or 3.3V nominal |
| 46 | REF1 | OUT | 14.318 MHz reference clock. |
| | FS2 ^{1, 2} | IN | Frequency select pin. Latched Input |
| 17 | CPU_STOP# ¹ | IN | Halts CPUCLK (0:1) clocks at logic 0 level, when input low (in Mobile Mode, MODE=0) |
| 47 | IOAPIC | OUT | IOAPIC clock output. 14.318 MHz Powered by VDDL1. |
| 48 | VDDL1 | PWR | Supply for IOAPIC, either 2.5 or 3.3V nominal |

Notes:

- 1: Internal Pull-up Resistor of 240K to 3.3V on indicated inputs
- 2: Bidirectional input/output pins, input logic levels are latched at internal power-on-reset. Use 10Kohm resistor to program logic Hi to VDD or GND for logic low.



Mode Pin - Power Management Input Control

| MODE, Pin 7 (Latched Input) | Pin 17 | Pin 18 |
|--------------------------------|----------------------|----------------------|
| 0 | CPU_STOP# (INPUT) | PCI_STOP# (INPUT) |
| 1 | SDRAM11 (OUTPUT) | SDRAM10 (OUTPUT) |

Power Management Functionality

| CPU_STOP# | PCI_STOP# | CPUCLK Outputs | PCICLK (0:4) | PCICLK_F, REF, 24/48MHz and SDRAM | Crystal OSC | VCO |
|-----------|-----------|-------------------|-----------------|--|----------------|---------|
| 0 | 1 | Stopped Low | Running | Running | Running | Running |
| 1 | 1 | Running | Running | Running | Running | Running |
| 1 | 0 | Running | Stopped Low | Running | Running | Running |
| 0 | 0 | Stopped Low | Stopped Low | Running | Running | Running |

Functionality

VDD1,2,3 = 3.3V±5%, VDDL1,2 = 2.5V±5% or 3.3±5%, TA=0 to 70°C
 Crystal (X1, X2) = 14.31818MHz

| FS2 | FS1 | FS0 | CPU (MHz) | PCICLK (MHz) | REF, IOAPIC (MHz) |
|-----|-----|-----|--------------------|---------------------------|----------------------|
| 1 | 1 | 1 | 100.2 | 33.3 (CPU/3) | 14.318 |
| 1 | 1 | 0 | 133.3 ¹ | 33.3 (CPU/4) ¹ | 14.318 |
| 1 | 0 | 1 | 112.0 ¹ | 37.3 (CPU/3) ¹ | 14.318 |
| 1 | 0 | 0 | 103 | 34.3 (CPU/3) | 14.318 |
| 0 | 1 | 1 | 66.8 | 33.4 (CPU/2) | 14.318 |
| 0 | 1 | 0 | 83.3 | 41.65 (CPU/2) | 14.318 |
| 0 | 0 | 1 | 75 | 37.5 (CPU/2) | 14.318 |
| 0 | 0 | 0 | 50 | 25 (CPU/2) | 14.318 |

Note1. Performance not guaranteed



General I²C serial interface information

- A. For the clock generator to be addressed by an I²C controller, the following address must be sent as a start sequence, with an acknowledge bit between each byte.

| | | | | | |
|----------------------------------|-----|-----------------------------|-----|---------------------------|-----|
| Clock Generator Address (7 bits) | ACK | + 8 bits dummy command code | ACK | + 8 bits dummy Byte count | ACK |
| A(6:0) & R/W# | | | | | |
| D2(H) | | | | | |

Then Byte 0, 1, 2, etc in sequence until STOP.

- B. The clock generator is a slave/receiver I²C component. It can read back the data stored in the latches for verification. (set R/W# to 1 above) **Read-Back will support Intel PIIX4 "Block-Read" protocol**, with a "Byte count" following the address with R/W#=1, then proceeding to Byte 0, 1, 2, ...until STOP.

| | | | |
|----------------------------------|-----|---------------------|-----|
| Clock Generator Address (7 bits) | ACK | Byte Count Readback | ACK |
| A(6:0) & R/W# | | | |
| D3(H) | | | |

Then Byte 0, 1, 2, etc. in sequence until STOP.

- C. The data transfer rate supported by this clock generator is 100K bits/sec (standard mode)
- D. The input is operating at 3.3V logic levels.
- E. The data byte format is 8 bit bytes.
- F. To simplify the clock generator I²C interface, the protocol is set to use only "**Block-Writes**" from the controller. The bytes must be accessed in sequential order from lowest to highest byte with the ability to stop after any complete byte has been transferred. The Command code and Byte count shown above must be sent, but the data is ignored for those two bytes. The data is loaded until a Stop sequence is issued.
- G. At power-on, all registers are set to a default condition. Byte 0 defaults to a 0, Bytes 1 through 5 default to a 1 (Enabled output state).

Serial Configuration Command Bitmap

Byte0: Functionality and Frequency Select Register (default = 0)

| Bit | Description | PWD | |
|---------|--|--------------------|-------------------|
| Bit 7 | 0 - ±1.5% Spread Spectrum Modulation 1 - ±0.5% Spread Spectrum Modulation | 0 | |
| Bit 6:4 | Bit6 Bit5 Bit4 | CPU clock | PCI |
| | 111 | 100.2 | 33.3 (CPU/3) |
| | 110 | 133.3 ² | 33.3 ² |
| | 101 | 112.0 ² | 37.3 ² |
| | 100 | 103 | 34.3 (CPU/3) |
| | 011 | 66.8 | 33.4 (CPU/2) |
| | 010 | 83.3 | 41.65(CPU/2) |
| | 001 | 75 | 37.5 (CPU/2) |
| 000 | 50 | 25 (CPU/2) | |
| Bit 3 | 0 - Frequency is selected by hardware select, Latched Inputs 1 - Frequency is selected by Bit 6:4 (above) | 0 | |
| Bit 2 | 0 - Spread Spectrum center spread type. 1 - Spread Spectrum down spread type. | 0 | |
| Bit 1 | 0 - Normal 1 - Spread Spectrum Enabled | 0 | |
| Bit 0 | 0 - Running 1- Tristate all outputs | 0 | |

Note1. Default at Power-up will be for latched logic inputs to define frequency. Bits 4, 5, 6 are default to 000, and if bit 3 is written to a 1 to use Bits 6:4, then these should be defined to desired frequency at same write cycle.

Note2. Performance not guaranteed

Note: PWD = Power-Up Default

I²C is a trademark of Philips Corporation



Byte 1: CPU, Active/Inactive Register (1 = enable, 0 = disable)

| Bit | Pin # | PWD | Description |
|-------|-------|-----|---------------------|
| Bit 7 | - | 1 | (Reserved) |
| Bit 6 | - | 1 | (Reserved) |
| Bit 5 | - | 1 | (Reserved) |
| Bit 4 | - | 1 | (Reserved) |
| Bit 3 | 40 | 1 | SDRAM12 (Act/Inact) |
| Bit 2 | 41 | 1 | SDRAM13 (Act/Inact) |
| Bit 1 | 43 | 1 | CPUCLK1 (Act/Inact) |
| Bit 0 | 44 | 1 | CPUCLK0 (Act/Inact) |

Notes:

1. Inactive means outputs are held LOW and are disabled from switching.

Byte 2: PCI Active/Inactive Register (1 = enable, 0 = disable)

| Bit | Pin # | PWD | Description |
|-------|-------|-----|----------------------|
| Bit 7 | - | 1 | (Reserved) |
| Bit 6 | 7 | 1 | PCICLK_F (Act/Inact) |
| Bit 5 | - | 1 | (Reserved) |
| Bit 4 | 14 | 1 | PCICLK4 (Act/Inact) |
| Bit 3 | 12 | 1 | PCICLK3 (Act/Inact) |
| Bit 2 | 11 | 1 | PCICLK2 (Act/Inact) |
| Bit 1 | 10 | 1 | PCICLK1 (Act/Inact) |
| Bit 0 | 8 | 1 | PCICLK0 (Act/Inact) |

Notes:

1. Inactive means outputs are held LOW and are disabled from switching.

Byte 3: SDRAM Active/Inactive Register (1 = enable, 0 = disable)

| Bit | Pin # | PWD | Description |
|-------|-------------|-----|---|
| Bit 7 | - | 1 | (Reserved) |
| Bit 6 | - | 1 | (Reserved) |
| Bit 5 | 26 | 1 | 48MHz (Act/Inact) |
| Bit 4 | 25 | 1 | 24 MHz (Act/Inact) |
| Bit 3 | - | 1 | (Reserved) |
| Bit 2 | 21,20,18,17 | 1 | SDRAM (8:11) (Active/Inactive) (SDRAM 10, 11 only in Desktop Mode, MODE=1) |
| Bit 1 | 32,31,29,28 | 1 | SDRAM (4:7) (Active/Inactive) |
| Bit 0 | 38,37,35,34 | 1 | SDRAM (0:3) (Active/Inactive) |

Notes:

1. Inactive means outputs are held LOW and are disabled from switching.



Byte 4: Reserved Active/Inactive Register (1 = enable, 0 = disable)

| Bit | Pin # | PWD | Description |
|-------|-------|-----|-------------|
| Bit 7 | - | 1 | (Reserved) |
| Bit 6 | - | 1 | (Reserved) |
| Bit 5 | - | 1 | (Reserved) |
| Bit 4 | - | 1 | (Reserved) |
| Bit 3 | - | 1 | (Reserved) |
| Bit 2 | - | 1 | (Reserved) |
| Bit 1 | - | 1 | (Reserved) |
| Bit 0 | - | 1 | (Reserved) |

Notes:

1. Inactive means outputs are held LOW and are disabled from switching.

Byte 5: Peripheral Active/Inactive Register (1 = enable, 0 = disable)

| Bit | Pin # | PWD | Description |
|-------|-------|-----|---------------------|
| Bit 7 | - | 1 | (Reserved) |
| Bit 6 | - | 1 | (Reserved) |
| Bit 5 | - | 1 | (Reserved) |
| Bit 4 | 47 | 1 | IOAPIC0 (Act/Inact) |
| Bit 3 | - | 1 | (Reserved) |
| Bit 2 | - | 1 | (Reserved) |
| Bit 1 | 46 | 1 | REF1 (Act/Inact) |
| Bit 0 | 2 | 1 | REF0 (Act/Inact) |

Notes:

1. Inactive means outputs are held LOW and are disabled from switching.
-



CPU_STOP# Timing Diagram

CPU_STOP# is an asynchronous input to the clock synthesizer. It is used to turn off the CPU clocks for low power operation. CPU_STOP# is synchronized by the ICS9148-26. The minimum that the CPU clock is enabled (CPU_STOP# high pulse) is 100 CPU clocks. All other clocks will continue to run while the CPU clocks are disabled. The CPU clocks will always be stopped in a low state and start in such a manner that guarantees the high pulse width is a full pulse. CPU clock on latency is less than 4 CPU clocks and CPU clock off latency is less than 4 CPU clocks.

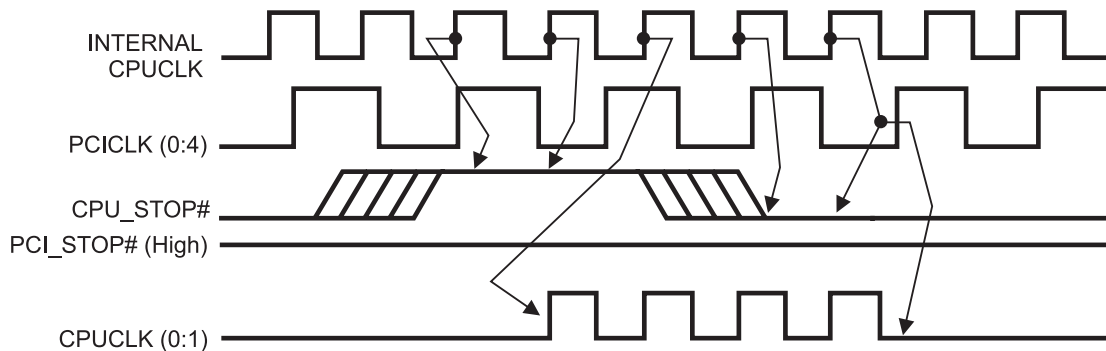

Notes:

1. All timing is referenced to the internal CPU clock.
2. CPU_STOP# is an asynchronous input and metastable conditions may exist. This signal is synchronized to the CPU clocks inside the ICS9148-26.
3. All other clocks continue to run undisturbed.
4. SDRAM outputs are controlled by Buffer in signal, not affected by the ICS9148-26 CPU_STOP# signal.



PCI_STOP# Timing Diagram

PCI_STOP# is an asynchronous input to the ICS9148-26. It is used to turn off the PCICLK (0:4) clocks for low power operation. PCI_STOP# is synchronized by the ICS9148-26 internally. The minimum that the PCICLK (0:4) clocks are enabled (PCI_STOP# high pulse) is at least 10 PCICLK (0:4) clocks. PCICLK (0:4) clocks are stopped in a low state and started with a full high pulse width guaranteed. PCICLK (0:4) clock on latency cycles are only one rising PCICLK clock off latency is one PCICLK clock.

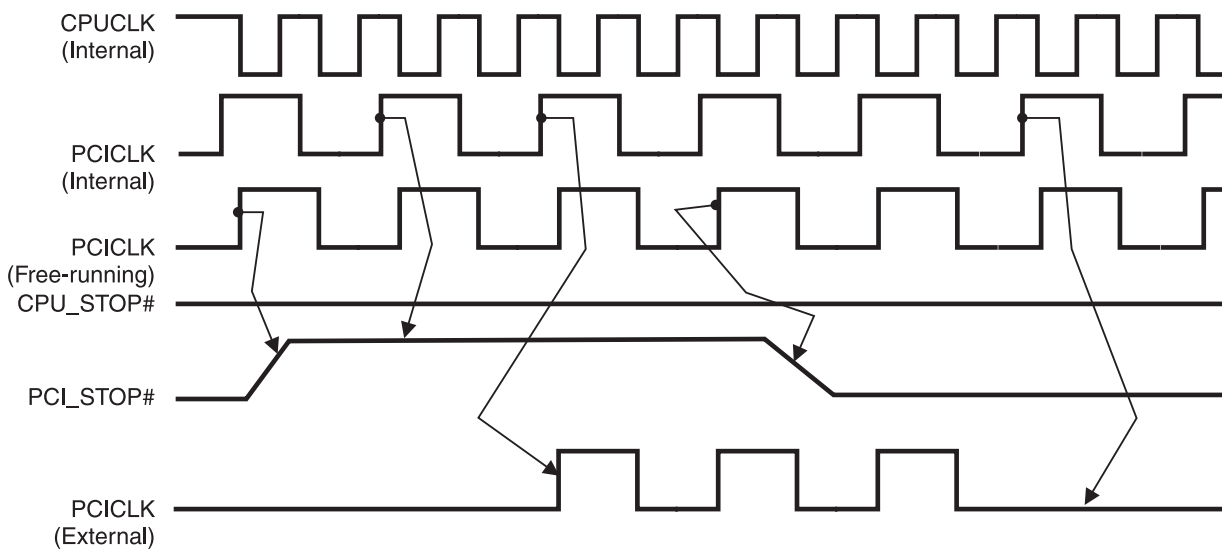

Notes:

- 1. All timing is referenced to the Internal CPUCLK (defined as inside the ICS9148 device.)
- 2. PCI_STOP# is an asynchronous input, and metastable conditions may exist. This signal is required to be synchronized inside the ICS9148.
- 3. All other clocks continue to run undisturbed.
- 4. CPU_STOP# is shown in a high (true) state.



Shared Pin Operation - Input/Output Pins

Pins 7,25,26,46 on the ICS9148-26 serve as dual signal functions to the device. During initial power-up, they act as input pins. The logic level (voltage) that is present on these pins at this time is read and stored into a 4-bit internal data latch. At the end of Power-On reset, (see AC characteristics for timing values), the device changes the mode of operations for these pins to an output function. In this mode the pins produce the specified buffered clocks to external loads.

To program (load) the internal configuration register for these pins, a resistor is connected to either the VDD (logic 1) power supply or the GND (logic 0) voltage potential. A 10 Kiloohm(10K) resistor is used to provide both the solid CMOS programming voltage needed during the power-up programming period and to provide an insignificant load on the output clock during the subsequent operating period.

Figs. 1 and 2 show the recommended means of implementing this function. In Fig. 1 either one of the resistors is loaded onto the board (selective stuffing) to configure the device's internal logic. Figs. 2a and b provide a single resistor loading option where either solder spot tabs or a physical jumper header may be used.

These figures illustrate the optimal PCB physical layout options. These configuration resistors are of such a large ohmic value that they do not effect the low impedance clock signals. The layouts have been optimized to provide as little impedance transition to the clock signal as possible, as it passes through the programming resistor pad(s).

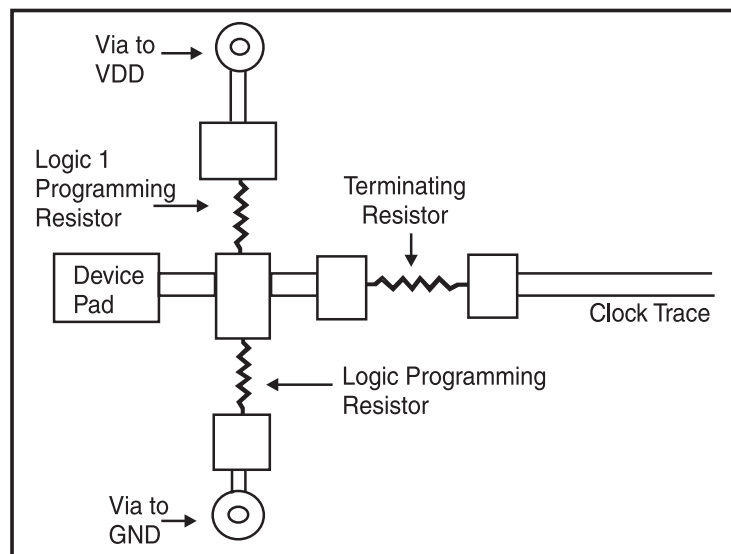

Fig. 1

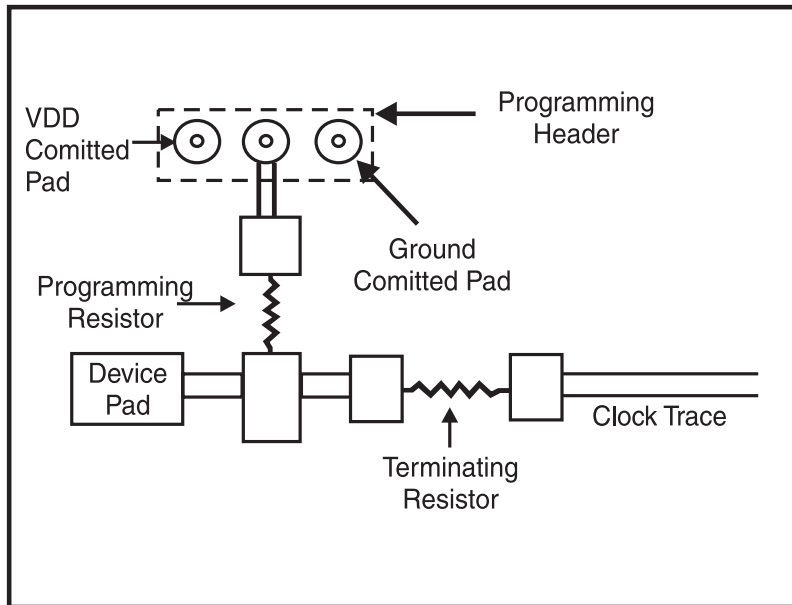

Fig. 2a

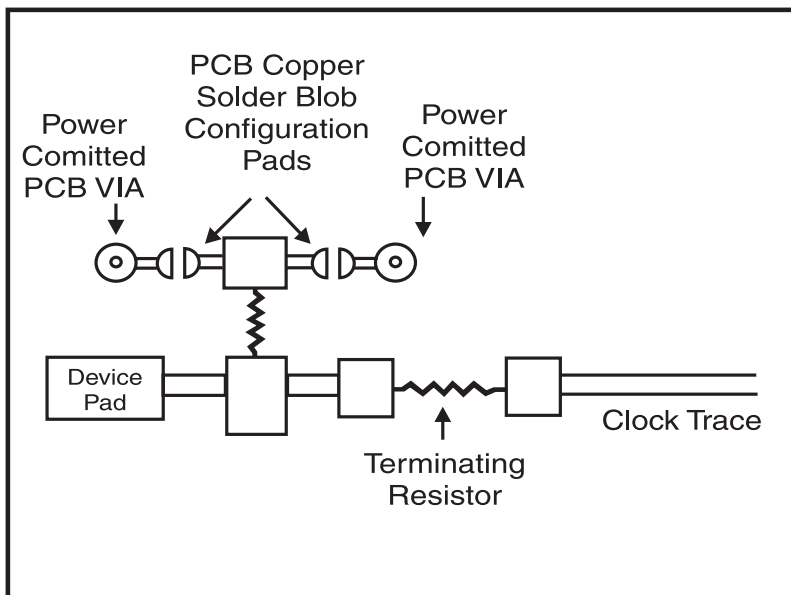

Fig. 2b



Absolute Maximum Ratings

| | |
|-------------------------------------|-------------------------------------|
| Supply Voltage | 7.0 V |
| Logic Inputs | GND–0.5 V to V _{DD} +0.5 V |
| Ambient Operating Temperature | 0°C to +70°C |
| Storage Temperature | –65°C to +150°C |

Stresses above those listed under *Absolute Maximum Ratings* may cause permanent damage to the device. These ratings are stress specifications only and functional operation of the device at these or any other conditions above those listed in the operational sections of the specifications is not implied. Exposure to absolute maximum rating conditions for extended periods may affect product reliability.

Electrical Characteristics - Input/Supply/Common Output Parameters

T_A = 0 - 70C; Supply Voltage V_{DD} = 3.3 V +/-5% (unless otherwise stated)

| PARAMETER | SYMBOL | CONDITIONS | MIN | TYP | MAX | UNITS |
|--------------------------------|----------------------|---|----------------------|--------|----------------------|-------|
| Input High Voltage | V _{IH} | | 2 | | V _{DD} +0.3 | V |
| Input Low Voltage | V _{IL} | | V _{SS} -0.3 | | 0.8 | V |
| Supply Current | I _{DD} | C _L = 0 pF; Select @ 66M | | 77 | 180 | mA |
| | I _{DDL} | | | 6.0 | 30 | mA |
| Input frequency | F _i | V _{DD} = 3.3 V; | | 14.318 | | MHz |
| Input Capacitance ¹ | C _{IN} | Logic Inputs | | | 5 | pF |
| | C _{INX} | X1 & X2 pins | 27 | 36 | 45 | pS |
| Transition Time ¹ | T _{trans} | To 1st crossing of target Freq. | | 1.5 | 3 | mS |
| Settling Time ¹ | T _s | From 1st crossing to 1% target Freq. | | | | mS |
| Clk Stabilization ¹ | T _{STAB} | From V _{DD} = 3.3 V to 1% target Freq. | | | 3 | mS |
| Skew ¹ | T _{CPU-BUS} | V _T = 1.5 V; | 1.0 | 2.2 | 4.0 | nS |

¹Guaranteed by design, not 100% tested in production.



Electrical Characteristics - CPU

T_A = 0 - 70C; V_{DD} = 3.3 V +/-5%; V_{DDL} = 2.5 V +/-5%; C_L = 20 pF (unless otherwise stated)

| PARAMETER | SYMBOL | CONDITIONS | MIN | TYP | MAX | UNITS |
|---------------------|----------------------------------|--|------|------|-------|-------|
| Output Impedance | R _{DSP2A} ¹ | V _O = V _{DD} *(0.5) | 10 | | 20 | Ω |
| Output Impedance | R _{DSN2A} ¹ | V _O = V _{DD} *(0.5) | 10 | | 20 | Ω |
| Output High Voltage | V _{OH2B} | I _{OH} = -12.0 mA | 2 | 2.3 | | V |
| Output Low Voltage | V _{OL2B} | I _{OL} = 12 mA | | 0.2 | 0.4 | V |
| Output High Current | I _{OH2B} | V _{OH} = 1.7 V | | -41 | -19 | mA |
| Output Low Current | I _{OL2B} | V _{OL} = 0.7 V | 19 | 37 | | mA |
| Rise Time | t _{r2A} ¹ | V _{OL} = 0.4 V, V _{OH} = 2.0 V | | 1.3 | 2.1 | nS |
| Fall Time | t _{f2A} ¹ | V _{OH} = 2.0 V, V _{OL} = 0.4 V | | 1.0 | 2.0 | nS |
| Duty Cycle | d _{t2A} ¹ | V _T = 1.25 V | 45.0 | 51.0 | 55.0 | % |
| Skew (Window) | t _{sk2A} ¹ | V _T = 1.25 V | | 120 | 250 | pS |
| Jitter | period(norm) | V _T = 1.25 V; 100MHz | 9.75 | 10 | 10.25 | nS |
| | period(spr) | V _T = 1.25 V; 100MHz | 9.75 | 10 | 10.35 | nS |
| | t _{j1s2A} ¹ | V _T = 1.25 V | | 120 | 350 | pS |
| | t _{jabs2A} ¹ | V _T = 1.25 V | -250 | 100 | +250 | |
| | Dev run avg | V _T = 1.25 V | | 150 | 250 | pS |

¹Guarenteed by design, not 100% tested in production.



Electrical Characteristics - 24M, 48M, REF 1

T_A = 0 - 70C; V_{DD} = V_{DDL} = 3.3 V +/-5%; C_L = 20 pF (unless otherwise stated)

| PARAMETER | SYMBOL | CONDITIONS | MIN | TYP | MAX | UNITS |
|---------------------|---------------------------------|--|------|------|------|-------|
| Output Impedance | R _{DSP5} ¹ | V _O = V _{DD} *(0.5) | | 20 | 60 | W |
| Output Impedance | R _{DSN5} ¹ | V _O = V _{DD} *(0.5) | | 55 | 100 | W |
| Output High Voltage | V _{OH5} | I _{OH} = -14 mA | 2.4 | 2.9 | | V |
| Output Low Voltage | V _{OL5} | I _{OL} = 6.0 mA | | 0.25 | 0.4 | V |
| Output High Current | I _{OH5} | V _{OH} = 2.0 V | | -42 | -20 | mA |
| Output Low Current | I _{OL5} | V _{OL} = 0.8 V | 10 | 18 | | mA |
| Rise Time | t _{r5} ¹ | V _{OL} = 0.8 V, V _{OH} = 2.4 V | | 1.1 | 2.0 | nS |
| Fall Time | t _{f5} ¹ | V _{OH} = 2.4 V, V _{OL} = 0.8 V | | 1.0 | 2.5 | nS |
| Duty Cycle | d _{t5} ¹ | V _T = 1.5 V | 40.0 | 52.0 | 60.0 | % |
| Jitter | t _{j1s5} ¹ | V _T = 1.5 V | | 100 | 250 | pS |
| | t _{jabs5} ¹ | V _T = 1.5 V | | 250 | 800 | pS |

¹Guarenteed by design, not 100% tested in production.



Electrical Characteristics - BUS

T_A = 0 - 70C; V_{DD} = 3.3 V +/-5%; C_L = 30 pF (unless otherwise stated)

| PARAMETER | SYMBOL | CONDITIONS | MIN | TYP | MAX | UNITS |
|---------------------|---------------------------------|--|------|------|------|-------|
| Output Impedance | R _{DSP1} ¹ | V _O = V _{DD} *(0.5) | 12 | 23 | 55 | Ω |
| Output Impedance | R _{DSN1} ¹ | V _O = V _{DD} *(0.5) | 12 | 20 | 55 | Ω |
| Output High Voltage | V _{OH1} | I _{OH} = -18 mA | 2.4 | 2.9 | | V |
| Output Low Voltage | V _{OL1} | I _{OL} = 9.4 mA | | 0.2 | 0.4 | V |
| Output High Current | I _{OH1} | V _{OH} = 2.0 V | | -58 | -22 | mA |
| Output Low Current | I _{OL1} | V _{OL} = 0.8 V | 25 | 52 | | mA |
| Rise Time | t _{r1} ¹ | V _{OL} = 0.8 V, V _{OH} = 2.4 V | | 1.5 | 2.0 | nS |
| Fall Time | t _{f1} ¹ | V _{OH} = 2.4 V, V _{OL} = 0.8 V | | 1.4 | 2.5 | nS |
| Duty Cycle | d _{t1} ¹ | V _T = 1.5 V | 45.0 | 50.0 | 55.0 | % |
| Skew | t _{sk1} ¹ | V _T = 1.5 V | | 80 | 250 | pS |
| Jitter | t _{j1s1} ¹ | V _T = 1.5 V | | 50 | 150 | pS |
| | t _{jabs1} ¹ | V _T = 1.5 V | | 200 | 500 | pS |

¹Guarenteed by design, not 100% tested in production.



Electrical Characteristics - SDRAM

$T_A = 0 - 70^\circ\text{C}$; $V_{DD} = V_{DDL} 3.3 \text{ V} \pm 5\%$; $C_L = 30 \text{ pF}$ (unless otherwise stated)

| PARAMETER | SYMBOL | CONDITIONS | MIN | TYP | MAX | UNITS |
|-----------------------------|---------------|--|-----|-----|-----|----------|
| Output Impedance | R_{DSP2A}^1 | $V_O = V_{DD}*(0.5)$ | 10 | | 20 | Ω |
| Output Impedance | R_{DSN2A}^1 | $V_O = V_{DD}*(0.5)$ | 10 | | 20 | Ω |
| Output High Voltage | V_{OH2A} | $I_{OH} = -28 \text{ mA}$ | 2.4 | 2.8 | | V |
| Output Low Voltage | V_{OL2A} | $I_{OL} = 19 \text{ mA}$ | | 0.3 | 0.4 | V |
| Output High Current | I_{OH2A} | $V_{OH} = 2.0 \text{ V}$ | | -72 | -42 | mA |
| Output Low Current | I_{OL2A} | $V_{OL} = 0.8 \text{ V}$ | 33 | 50 | | mA |
| Rise Time | t_{r2A}^1 | $V_{OL} = 0.8 \text{ V}, V_{OH} = 2.4 \text{ V}$ | | 1.1 | 2.0 | nS |
| Fall Time | t_{f2A}^1 | $V_{OH} = 2.4 \text{ V}, V_{OL} = 0.8 \text{ V}$ | | 1.5 | 2.5 | nS |
| Duty Cycle | d_{t2A}^1 | $V_T = 1.5 \text{ V}$ | 55 | 65 | 75 | % |
| Skew (output to output) | t_{sk2A}^1 | $V_T = 1.5 \text{ V}$ | | 200 | 600 | pS |
| Skew (Bufferin to output) | t_{sk2A}^1 | $V_T = 1.5 \text{ V}$ | | 5.5 | 7.0 | nS |

¹Guarenteed by design, not 100% tested in production.



General Layout Precautions:

- 1) Use a ground plane on the top layer of the PCB in all areas not used by traces.
- 2) Make all power traces and vias as wide as possible to lower inductance.

Notes:

- 1 All clock outputs should have series terminating resistor. Not shown in all places to improve readability of diagram
- 2 Optional EMI capacitor should be used on all CPU, SDRAM, and PCI outputs.
- 3 Optional crystal load capacitors are recommended.

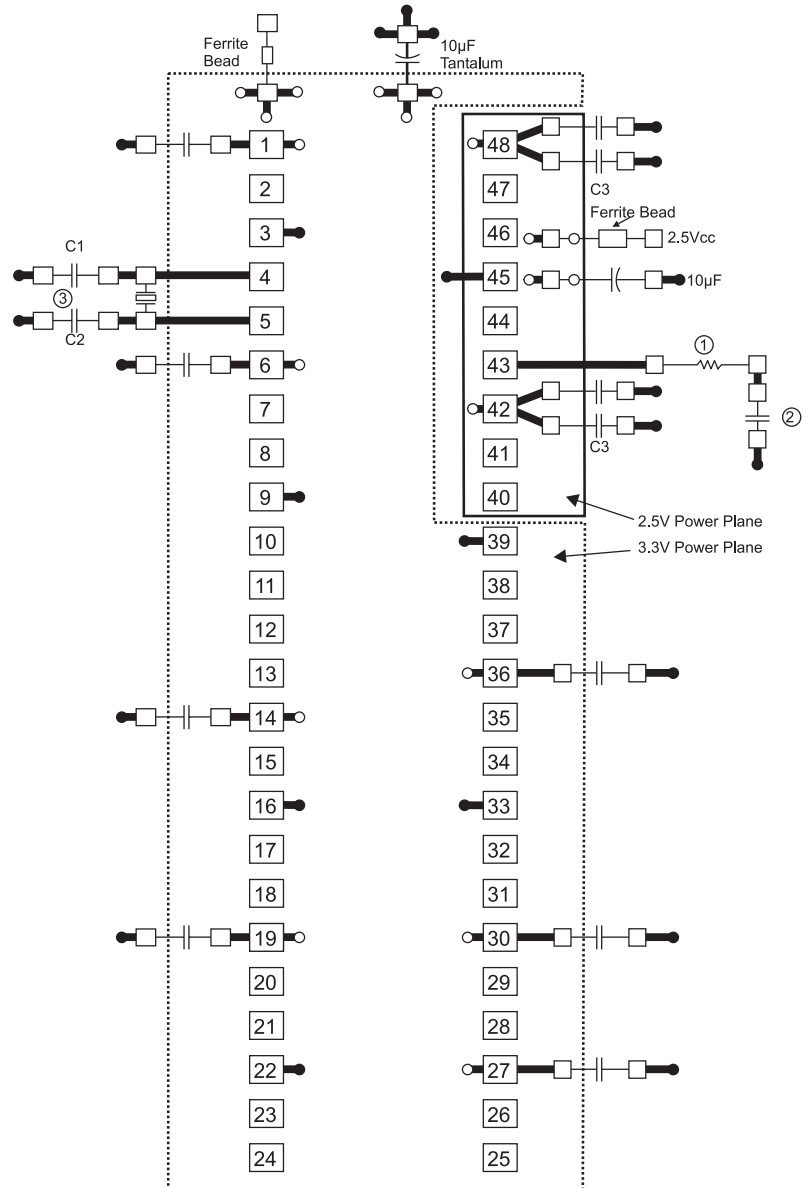

Capacitor Values:

C1, C2 : Crystal load values determined by user

C3 : 100pF ceramic

All unmarked capacitors are 0.01µF ceramic

- = Ground Plane Connection
- = Power Plane Connection
- = Solder Pads

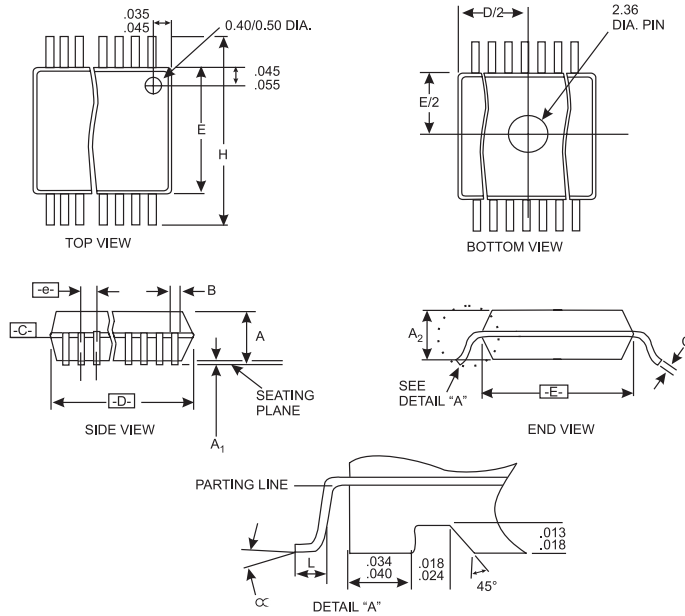

SSOP Package

| SYMBOL | COMMON DIMENSIONS | | | VARIATIONS | D | | | N |
|--------|-------------------|------|-------|------------|------|------|------|----|
| | MIN. | NOM. | MAX. | | MIN. | NOM. | MAX. | |
| A | .095 | .101 | .110 | AC | .620 | .625 | .630 | 48 |
| A1 | .008 | .012 | .016 | | | | | |
| A2 | .088 | .090 | .092 | | | | | |
| B | .008 | .010 | .0135 | | | | | |
| C | .005 | - | .010 | | | | | |
| D | See Variations | | | | | | | |
| E | .292 | .296 | .299 | | | | | |
| e | 0.025 BSC | | | | | | | |
| H | .400 | .406 | .410 | | | | | |
| h | .010 | .013 | .016 | | | | | |
| L | .024 | .032 | .040 | | | | | |
| N | See Variations | | | | | | | |
| ∞ | 0° | 5° | 8° | | | | | |
| X | .085 | .093 | .100 | | | | | |

Ordering Information

ICS9148F-26

Example:

ICS XXXX F - PPP

