

Frequency Generator for Pentium™ Based Systems

General Description

The **ICS9169C-271** is a low-cost frequency generator designed specifically for Pentium based chip set systems. The integrated buffer minimizes skew and provides all the clocks required. A 14.318 MHz XTAL oscillator provides the reference clock to generate standard Pentium frequencies. The CPU clock makes gradual frequency transitions without violating the PLL timing of internal microprocessor clock multipliers. A raised frequency setting of 68.5MHz is available for Turbo-mode of the 66.8MHz CPU. The **ICS9169C-271** contains 12 CPU clocks, 4 PCI clocks, 1 REF at 48MHz and 1 at 24MHz.

The twelve CPU clock outputs provide sufficient clocks for the CPU, chip set, memory and up to two DIMM connectors (with four clocks to each DIMM). Either synchronous(CPU/2) or asynchronous (32 MHz) PCI busoperation can be selected by latching data on the BSEL input.

Features

- Twelve selectable CPU clocks operate up to 83.3MHz
- Maximum CPU jitter of $\pm 200ps$
- Six BUS clocks support sync or async bus operation
- $\pm 250ps$ skew for all synchronous clock edges
- CPU clocks BUS clocks skew 1-4ns (CPU early)
- Integrated buffer outputs drive up to 30pF loads
- 3.0V - 3.7V supply range, CPU(1:12) outputs 2.5V(2.375-2.62V) VDD option
- 32-pin SOIC/SOJ package
- Logic inputs latched at Power-On for frequency selection saving pins as Input/Output
- 48 MHz clock for USB support and 24 MHz clock for FD.

Block Diagram

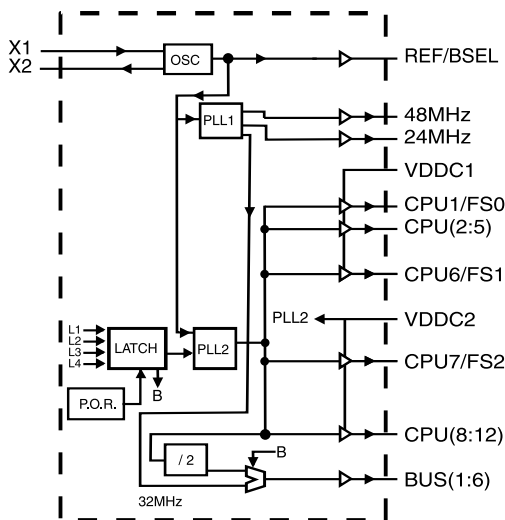

Pin Configuration

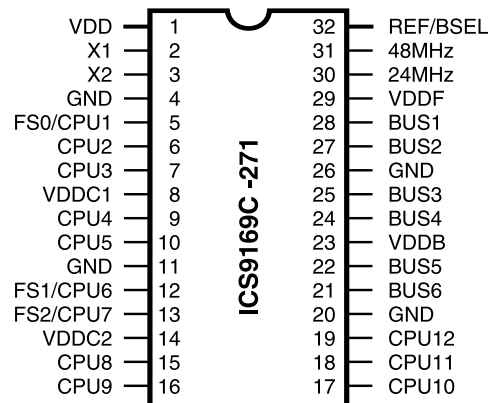

32-Pin SOIC/SOJ

Functionality

3.3V \pm 10%, 0-70°C
Crystal (X1, X2) = 14.31818 MHz

VDD Groups:

VDD = X1, X2, REF/BSEL
VDDC1 = CPU1-6
VDDC2 = CPU7-12 & PLL Core
VDDDB = BUS1-6
VDDF = 48/24 MHz

Latched Inputs:

L1 = BSEL
L2 = FS0
L3 = FS1
L4 = FS2

ADDRESS SELECT			CPU(1:12) (MHz)	BUS (1:6)MHz		48MHz	24MHz	REF
FS2	FS1	FS0		BSEL=1	BSEL=0			
0	0	0	50	25	32	48	24	REF
0	0	1	60	30	32	48	24	REF
0	1	0	66.8	33.4	32	48	24	REF
0	1	1	75.9	32	32	48	24	REF
1	0	0	55	27.5	32	48	24	REF
1	0	1	75.9	37.5	32	48	24	REF
1	1	0	83.3	41.7	32	48	24	REF
1	1	1	68.5	34.25	32	48	24	REF

Pentium is a trademark of Intel Corporation.



Pin Descriptions

PIN NUMBER	PIN NAME	TYPE	DESCRIPTION
1	VDD	PWR	Power for device logic and crystal oscillator circuit and 14.318 MHz output.
2	X1	IN	XTAL or external reference frequency input. This input includes XTAL load capacitance and feedback bias for a 12-16MHz crystal, nominally 14.31818MHz External crystal load of 30pF to GND recommended for VDD power on faster than 2.0ms.
3	X2	OUT	XTAL output which includes XTAL load capacitance. External crystal load of 10pF to GND recommended for VDD power on faster than 2.0ms.
4,11,20,26	GND	PWR	Ground for device logic.
5	CPU(1)	OUT	Processor clock output which is a multiple of the input reference frequency.
	FS0	IN	Frequency multiplier select pins. 350K internal pull up.
6,7,9,10,15,16,17,18,19	CPU (2:5) (8:12)	OUT	Processor clock outputs which are a multiple of the input reference frequency.
8	VDDC1	PWR	Power for CPU(1:6) output buffers only. Can be reduced VDD for 2.5V (2.375-2.62V) next generation processor clocks.
12	CPU(6)	OUT	Processor clock output which is a multiple of the input reference frequency internal pull up devices.
	FS1	IN	Frequency multiplier select pin. See shared pin description. 350K internal pull up.
13	CPU(7)	OUT	Processor clock output which is a multiple of the input reference frequency internal pull up devices.
	FS2	IN	Frequency multiplier select pin. See shared pin description. 350K internal pull up.
14	VDDC2	PWR	Power for CPU PLL, logic and CPU(7:12)output buffers. Must be nominal 3.3V (3.0 to 3.7V)
21,22,24,25,27,28	BUS (1:6)	OUT	BUS clock outputs which are a multiple of the input reference clock.
23	VDDDB	PWR	Power for BUS clock buffers BUS(1:6).
29	VDDDF	PWR	Power for fixed clock buffer (48 MHz, 24 Mhz).
30	24MHz	OUT	Fixed 24MHz clock (assuming a 14.31818MHz REF frequency).
31	48MHz	OUT	Fixed 48MHz clock (assuming a 14.31818MHz REF frequency).
32	REF	OUT	Fixed 14.31818MHz clock (assuming a 14.31818MHz REF frequency).
	BSEL	IN	Selection for synchronous or asynchronous bus clock operation. See shared pin programming description late in this data sheet for further explanation. 350K internal pull up.

* The internal pull up will vary from 350K to 500K based on temperature



Shared Pin Operation - Input/Output Pins

Shared Pin Operation - Input/Output Pins 5, 12, 13 and 32 on the ICS9169C-271 serve as dual signal functions to the device. During initial power-up, they act as input pins. The logic level (voltage) that is present on these pins at this time is read and stored into a 4-bit internal data latch. At the end of Power-On reset, (see AC characteristics for timing values), the device changes the mode of operation for these pins to an output function. In this mode the pins produce the specified buffered clocks to external loads.

To program (load) the internal configuration register for these pins, a resistor is connected to either the VDD (logic 1) power supply or the GND (logic 0) voltage potential. A 10 Kiloohm (10K) resistor is used to provide both the solid CMOS programming voltage needed during the power-up programming period and to provide an insignificant load on the output clock during the subsequent operating period.

Figs. 1 and 2 show the recommended means of implementing this function. In Fig. 1 either one of the resistors is loaded onto the board (selective stuffing) to configure the device's internal logic. Figs. 2a and b provide a single resistor loading option where either solder spot tabs or a physical jumper header may be used.

These figures illustrate the optimal PCB physical layout options. These configuration resistors are of such a large ohmic value that they do not effect the low impedance clock signals. The layouts have been optimized to provide as little impedance transition to the clock signal as possible, as it passes through the programming resistor pad(s).

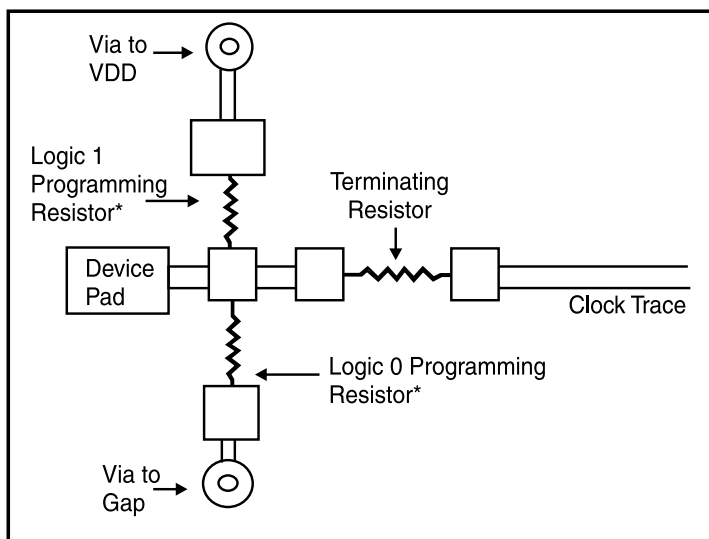

Fig. 1

Test Mode Operation

The ICS9169C-271 includes a production test verification mode of operation. This requires that the FS0 and FS1 pins be programmed to a logic high and the FS2 pin be programmed to a logic low (see Shared Pin Operation section). In this mode the device will output the following frequencies.

Pin	Frequency	
REF	REF	
48MHz	REF/2	
24MHz	REF/4	
CPU (1:12)	REF/2	
BUS (1:6)	BSEL=1	REF/4
	BSEL = 0	REF/3

Note: REF is the frequency of either the crystal connected between the devices X1 and X2 or, in the case of a device being driven by an external reference clock, the frequency of the reference (or test) clock on the device's X1 pin.

(Resistors are surface mount devices shown schematically between 5.m. pads)

*use only one programming resistor

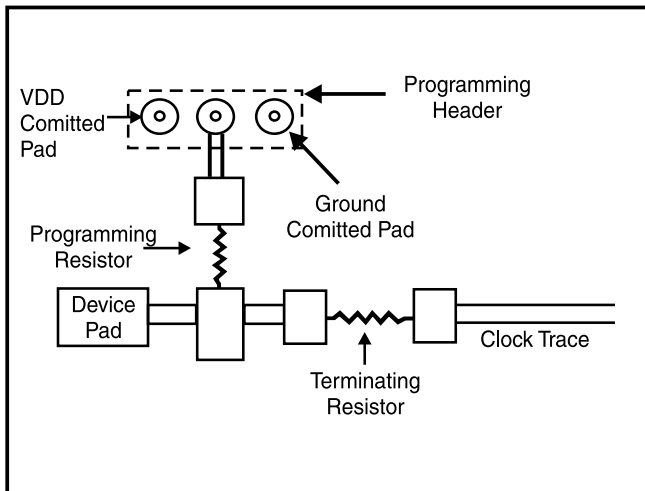

Fig. 2a

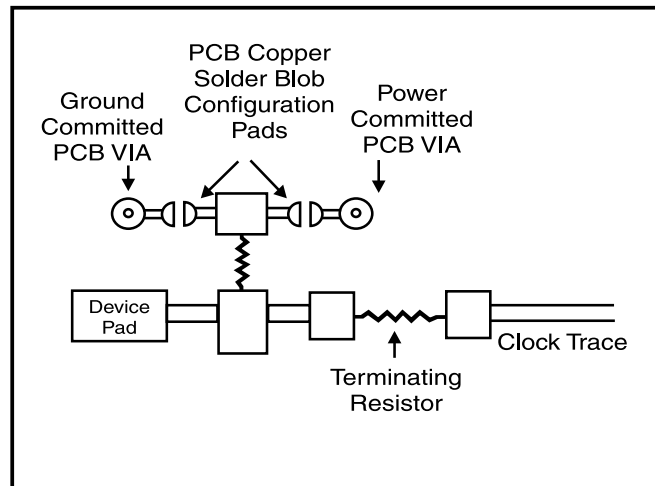

Fig. 2b

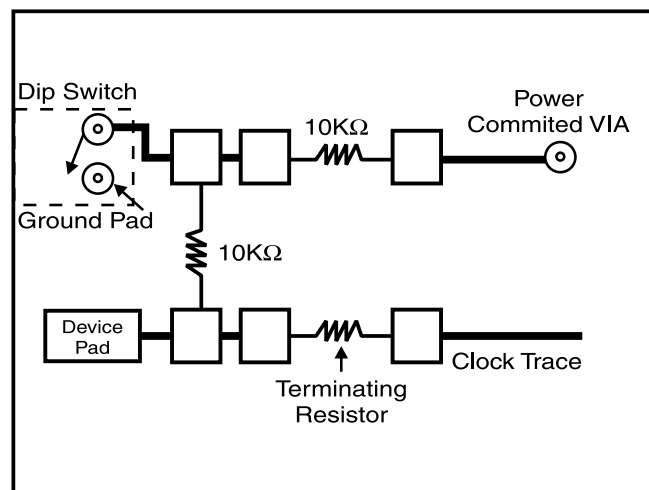

Fig. 3



Technical Pin Function Descriptions

VDD

This is the power supply to the internal logic of the device as well as the following clock output buffers:

- A. REF clock output buffers
- B. BUS clock output buffers
- C. Fixed clock output buffers

This pin may be operated at any voltage between 3.0 and 5.5 volts. Clocks from the listed buffers that it supplies will have a voltage swing from ground to this level. For the actual guaranteed high and low voltage levels of these clocks, please consult the AC parameter table in this data sheet.

GND

This is the power supply ground return pin for the internal logic of the device as well as the following clock output buffers:

- A. REF clock output buffers
- B. BUS clock output buffers
- C. CPU clock output buffers
- D. Fixed clock output buffers

X1

This pin serves one of two functions. When the device is used with a crystal, X1 acts as the input pin for the reference signal that comes from the discrete crystal. When the device is driven by an external clock signal, X1 is the device' input pin for that reference clock. This pin also implements an internal crystal loading capacitor that is connected to ground. See the data tables for the value of the capacitor.

X2

This pin is used only when the device uses a Crystal as the reference frequency source. In this mode of operation, X2 is an output signal that drives (or excites) the discrete crystal. This pin also implements an internal crystal loading capacitor that is connected to ground. See the data tables for the value of the capacitor.

CPU

This pin is the clock output that drives processor and other CPU related circuitry that require clocks which are in tight skew tolerance with the CPU clock. The voltage swing of these clocks is controlled by that which is applied to the VDDC pins of the device. See note on VDDC (1:2). See the Functionality table at the beginning of this data sheet for a list of the specific frequencies that this clock operates at and the selection codes that are necessary to produce these frequencies.

BUS

This pin is the clock output that is intended to drive the systems plug-in card bus. The voltage swing of these

clocks is control-led by the supply that is applied to the VDD pin of the device. See the Functionality table at the beginning of this data sheet for a list of the specific frequencies that this clock operates at and the selection codes that are necessary to produce these frequencies.

FS0, FS1, FS2

These pins control the frequency of the clocks at the CPU, CPUL, BUS & SDRAM pins. See the Functionality table at the beginning of this data sheet for a list of the specific frequencies that this clock operates at and the selection codes that are necessary to produce these frequencies. The device reads these pins at power-up and stores the programmed selection code in an internal data latch. (See programming section of this data sheet for configuration circuitry recommendations.

BSEL

This pin controls whether the BUS clocks will be synchronous (run at half the frequency) with the CPU and CPUL clocks or whether they will be asynchronous (run at a pre-programmed fixed frequency) clock rate. It is a shared pin and is programmed the same way as the frequency select pins.

VDDC (1:2)

These are the power supply pins for the CPU (1:6) and CPU (7:12) clock buffers. By separating the clock power pins, each group can receive the appropriate power decoupling and bypassing necessary to minimize EMI and crosstalk between the individual signals. VDDC1 can be reduced to 2.5V VDD for advanced processor clocks, which will bring CPU (1:6) outputs at 0 to 2.5V output swings.

48 MHz

This is a fixed frequency clock that is typically used to drive Super I/O peripheral device needs.

24 MHz

This is a fixed frequency clock that is typically used to drive Keyboard controller clock needs.

REF

This is a fixed frequency clock that runs at the same frequency as the input reference clock (typically 14.31818 MHz) is and typically used to drive Video and ISA BUS requirements.

VDDB

This power pin supplies the BUS clock buffers.

VDDF

This power pin supplies the 48/24 MHz clocks.



Absolute Maximum Ratings

Supply Voltage	7.0V
Logic Inputs	GND –0.5V to V _{DD} +0.5V
Ambient Operating Temperature	0°C to +70°C
Storage Temperature	–65°C to +150°C

Stresses above those listed under *Absolute Maximum Ratings* may cause permanent damage to the device. These ratings are stress specifications only and functional operation of the device at these or any other conditions above those listed in the operational sections of the specifications is not implied. Exposure to absolute maximum rating conditions for extended periods may affect product reliability.

Electrical Characteristics at 3.3V

V_{DD} = 3.0 – 3.7 V, T_A = 0 – 70°C unless otherwise stated

DC Characteristics						
PARAMETER	SYMBOL	TEST CONDITIONS	MIN	TYP	MAX	UNITS
Input Low Voltage	V _{IL}		-	-	0.2V _{DD}	V
Input High Voltage	V _{IH}		0.7V _{DD}	-	-	V
Input Low Current	I _{IL}	V _{IN} =0V	-28.0	-10.5	-	μA
Input High Current	I _{IH}	V _{IN} =V _{DD}	-5.0	-	5.0	μA
Output Low Current ¹	I _{OL}	V _{OL} =0.8V; for CPU, BUS, Fixed CLKs	16.0	25.0	-	mA
Output High Current ¹	I _{OH}	V _{OL} =2.0V; for CPU, BUS, Fixed CLKs	-	-30.0	-14.0	mA
Output Low Current ¹	I _{OL}	V _{OL} =0.8V; for REF CLK	19.0	30.0	-	mA
Output High Current ¹	I _{OH}	V _{OL} =2.0V; for REF CLK	-	-38.0	-16.0	mA
Output Low Voltage ¹	V _{OL}	I _{OL} = 8mA; for CPU, BUS, Fixed CLKs	-	0.3	0.4	V
Output High Voltage ¹	V _{OH}	I _{OH} = -8mA; for CPU, BUS, Fixed CLKs	2.4	2.8	-	V
Output Low Voltage ¹	V _{OL}	I _{OL} = 10mA; for REF CLK	-	0.3	0.4	V
Output High Voltage ¹	V _{OH}	I _{OH} = -15mA; for REF CLK	2.4	2.8	-	V
Supply Current	I _{DD}	@ 66.6 MHz; all outputs unloaded	-	90	180	mA

Note 1: Parameter is guaranteed by design and characterization. Not 100% tested in production.



Electrical Characteristics at 3.3V

$V_{DD} = 3.0 - 3.7V$, $T_A = 0 - 70^\circ C$ unless otherwise stated

AC Characteristics						
PARAMETER	SYMBOL	TEST CONDITIONS	MIN	TYP	MAX	UNITS
Rise Time ¹	T_{r1}	20pF load, 0.8 to 2.0V CPU & BUS	-	0.9	1.5	ns
Fall Time ¹	T_{f1}	20pF load, 2.0 to 0.8V CPU & BUS	-	0.8	1.4	ns
Rise Time ¹	T_{r2}	20pF load, 20% to 80% CPU & BUS	-	1.5	2.5	ns
Fall Time ¹	T_{f2}	20pF load, 80% to 20% CPU & BUS	-	1.4	2.4	ns
Duty Cycle ¹	D_t	20pF load @ $V_{OUT}=1.4V$	45	50	60	%
Jitter, One Sigma ¹	T_{j1s1}	CPU & BUS Clocks; Load=20pF, BSEL=1	-	50	150	ps
Jitter, Absolute ¹	T_{jab1}	CPU & BUS Clocks; Load=20pF, BSEL=1	-250	-	250	ps
Jitter, One Sigma ¹	T_{j1s2}	REF & Fixed CLKs; Load=20pF	-	1	3	%
Jitter, Absolute ¹	T_{jab2}	REF & Fixed CLKs; Load=20pF	-5	2	5	%
Input Frequency ¹	F_i		12.0	14.318	16.0	MHz
Logic Input Capacitance ¹	C_{IN}	Logic input pins	-	5	-	pF
Crystal Oscillator Capacitance ¹	C_{INX}	X1, X2 pins	-	18	-	pF
Power-on Time ¹	t_{on}	From $V_{DD}=1.6V$ to 1st crossing of 66.6 MHz V_{DD} supply ramp < 40ms	-	2.5	4.5	ms
Clock Skew ¹	T_{sk1}	CPU to CPU; Load=20pF; @ 1.4V	-	150	250	ps
Clock Skew ¹	T_{sk2}	BUS to BUS; Load=20pF; @ 1.4V	-	160	500	ps
Clock Skew ¹	T_{sk3}	CPU to BUS; Load=20pF; @ 1.4V (CPU is early)	1	2.2	4	ns
Clock Skew ¹	T_{sk4}	CPU (@3.3V) to CPU (@2.5V) (2.5V CPU is late)		0.5	1	ns

Note 1: Parameter is guaranteed by design and characterization. Not 100% tested in production.

ICS9169C-271

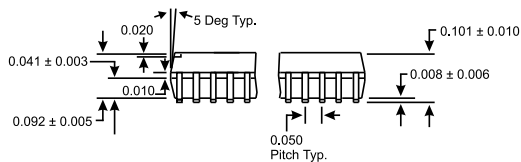
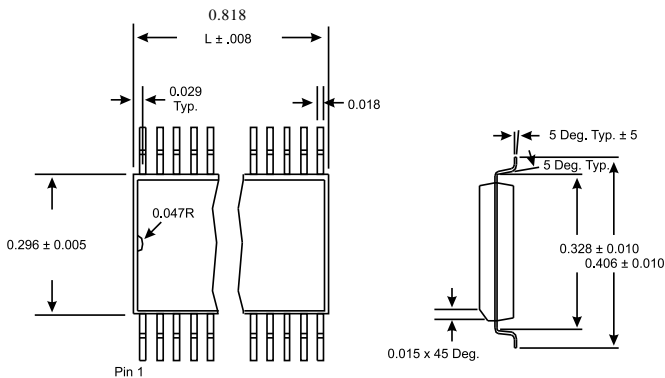

SOIC Package

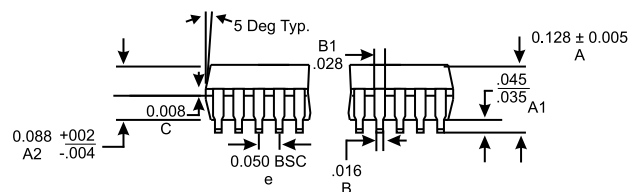
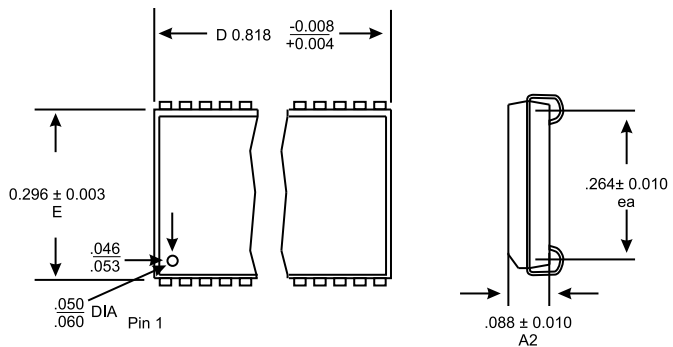

SOJ Package

Ordering Information

ICS9169CM-271

ICS9169CJ-271

Example:

ICS XXXX M-PPP

Pattern Number (2 or 3 digit number for parts with ROM code patterns)

Package Type

M=SOIC

J=SOJ

Device Type (consists of 3 or 4 digit numbers)

Prefix

ICS, AV = Standard Device