

Low Skew Output Buffer

General Description

The **AV9172** is designed to generate low skew clocks for clock distribution in high-performance PCs and workstations. It uses phase-locked loop technology to align the phase and frequency of the output clocks with an input reference clock. Because the input to output skew is guaranteed to ± 500 ps, the part acts as a “zero delay” buffer.

The **AV9172** has six configurable outputs. The **AV9172-01** version has one output that runs at the same phase and frequency as the reference clock. A second output runs at the same frequency as the reference, but can either be in phase or 180° out of phase from the input clock. Two outputs are provided that are at twice the reference frequency and in phase with the reference clock. The final outputs can be programmed to be replicas of the 2x clocks or non-overlapping two phase clocks at twice the reference frequency. The **AV9172-01** and **AV9172-03** operates with input clocks from 10 MHz to 50 MHz while producing outputs from 10 MHz to 100 MHz. The **AV9172-07** operates with input clocks from 20 to 100 MHz.

The use of a phase-locked loop (PLL) allows the output clocks to run at multiples of the input clock. This permits routing of a lower speed clock and local generation of a required high speed clock. Synchronization of the phase relationship between the input clock and the output clocks is accomplished when one output clock is connected to the input pin FBIN. The PLL circuitry matches rising edges of the input clock and output clocks.

Features

- **AV9172-07** input is 66 MHz with 66 and 33 MHz output buffers
- **AV9172-01** is pin compatible with Gazelle GA1210E
- ± 250 ps skew (max) between outputs
- ± 500 ps skew (max) between input and outputs
- Input frequency range from 10 MHz to 50 MHz (-01, -03) and from 20 MHz to 100 MHz (-07)
- Output frequency range from 10 MHz to 100 MHz (-01, -03, -07)
- Special mode for two-phase clock generation
- Inputs and outputs are fully TTL-compatible
- CMOS process results in low power supply current
- High drive, 25mA outputs
- Low cost
- 16-pin SOIC (150-mil) or 16-pin PDIP package

The **AV9172** is fabricated using CMOS technology which results in much lower power consumption and cost compared with the gallium arsenide-based GA1210E. The typical operating current for the **AV9172** is 50mA versus 120mA for the GA1210E.

ICS offers several versions of the **AV9172**. The different devices are shown below:

PART	DESCRIPTION
AV9172-01	Second source of GA1210E
AV9172-03	Clock doubler and buffer
AV9172-07	Clock buffer for 66 MHz input

Block Diagram

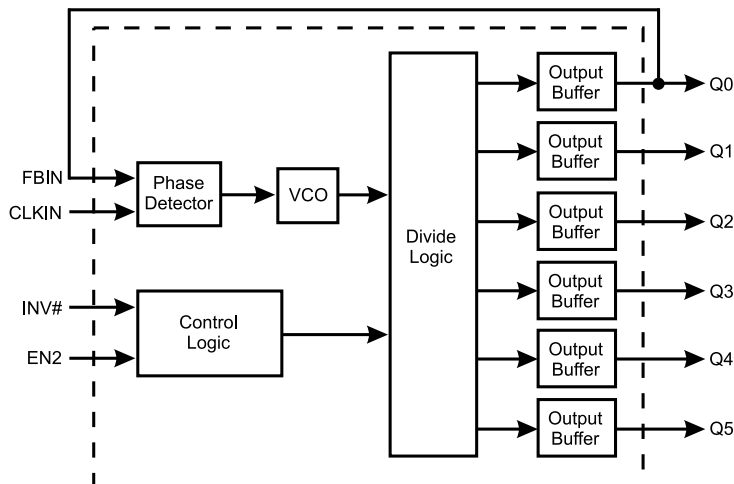



AV9172

Pin Configuration

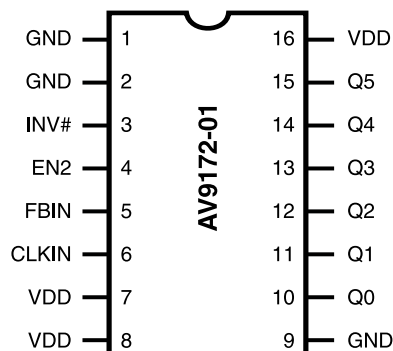

16-Pin SOIC or 16-Pin PDIP

Functionality Table for AV9172-01

CLKIN input frequency range 10 to 50 MHz.

EN2	INV#	Q0	Q1	Q2	Q3	Q4	Q5
0	0	1X	1X#	2X	2X	2X	2X
0	1	1X	1X	2X	2X	2X	2X
1	0	1X	1X#	2X	2X	Ø1	Ø2
1	1	1X	1X	2X	2X	Ø1	Ø2

Notes:

- 1X designates that the output is a replica of CLKIN.
- 2X designates that the output is twice the frequency of CLKIN, and in phase.
- 1X# means that the output is at the same frequency and 180°C out of phase (inverted) from CLKIN.
- Ø1 will produce a ¼ duty cycle clock of CLKIN.
- Ø2 will produce a ¼ duty cycle clock delayed 180° from CLKIN.

Pin Description for AV9172-01

PIN NUMBER	PIN NAME	TYPE	DESCRIPTION
1	GND	-	GROUND.
2	GND	-	GROUND.
3	INV#	Input	INV# Inverts Q1 when low. (-01 [divisor select -03, -07])
4	EN	Input	EN converts Q4 and Q5 to phase clocks when high.
5	FBIN	Input	FEEDBACK INPUT from output Q0.
6	CLKIN	Input	INPUT for reference clock.
7	VDD	-	Power supply (+5V).
8	VDD	-	Power supply (+5V).
9	GND	-	GROUND.
10	Q0	Output	Q0 phase and frequency same as input (1X). Feed back to pin 5.
11	Q1	Output	Q1 is a 1x clock in phase or 180° out of phase with input.
12	Q2	Output	Q2 twice the frequency of Q0 (2x).
13	Q3	Output	Q3 twice the frequency of Q0 (2x).
14	Q4	Output	Q4 is either a 2X clock or a two-phase clock - see configuration table.
15	Q5	Output	Q5 is either a 2X clock or a two-phase clock - see configuration table.
16	VDD	-	Power supply (+5V).



Timing Diagrams for AV9172-01

EN2 = 0 INV# = 0
FBIN = Q0

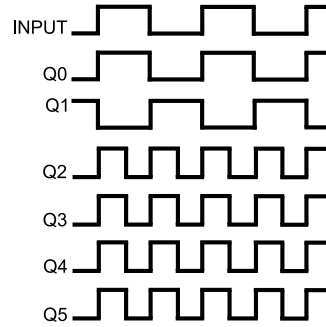
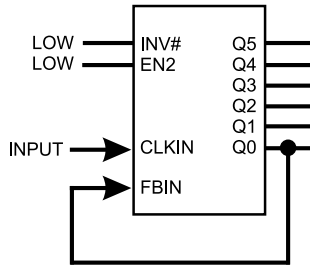

EN2 = 0 INV# = 1
FBIN = Q0

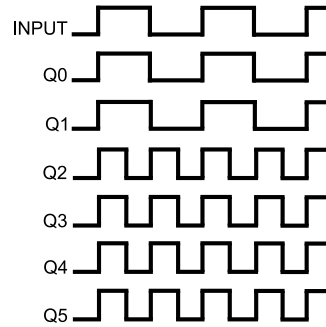
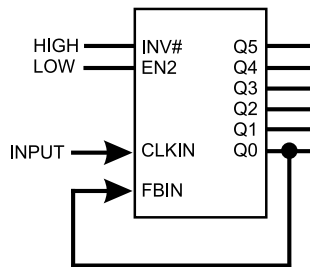

EN2 = 1 INV# = 0
FBIN = Q0

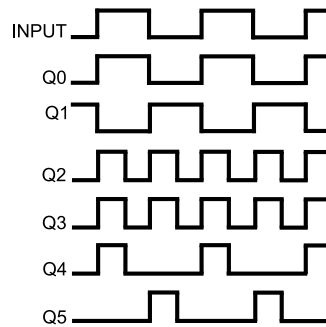
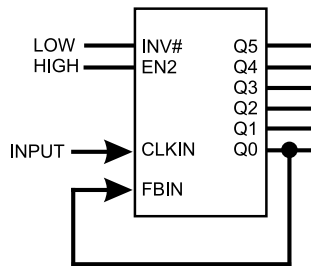

EN2 = 1 INV# = 1
FBIN = Q0

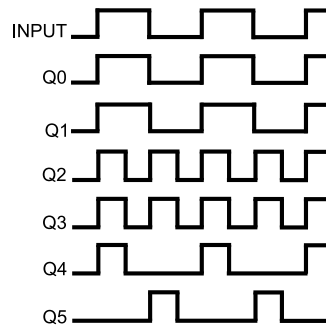
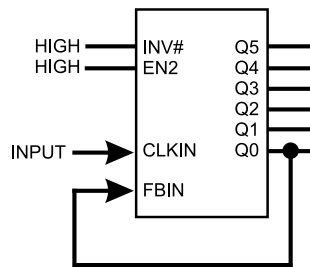



AV9172

Pin Configuration

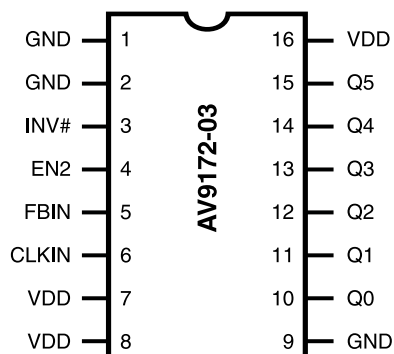

16-Pin SOIC or 16-Pin PDIP

Functionality Table for AV9172-03

CLKIN Input Frequency=X, input range is 10 to 50 MHz.

EN2	INV#	Q0	Q1	Q2	Q3	Q4	Q5
0	0	2X	2X	2X	2X	2X	2X
1	0	2X	2X	2X	2X	2X	1X
0	1	2X	2X	2X	1X	1X	2X
1	1	2X	2X	2X	1X	1X	1X

Example Table for AV9172-03

(33 MHz input, all frequencies in MHz.)

EN2	INV#	Q0	Q1	Q2	Q3	Q4	Q5
0	0	66	66	66	66	66	66
1	0	66	66	66	66	66	33
0	1	66	66	66	33	33	66
1	1	66	66	66	33	33	33

Timing Diagram for AV9172-03

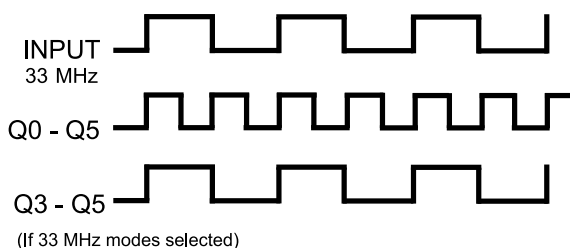
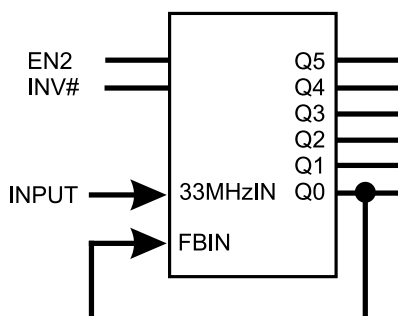

Note: The phase alignment between the 1X clock outputs and reference clocks input will be either at a 0 or 180 degrees offset if the 2X clock is used as the feedback signal (connected to the FBIN pin). Which relationship occurs is totally random and has the potential to change any time the device has its VDD supply cycled off or the devices input clock removed.



Pin Configuration

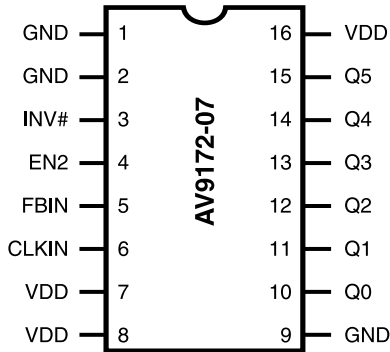

16-Pin SOIC or 16-Pin PDIP

Functionality Table for AV9172-07

CLKIN Input Frequency=X, input range is 20 to 100 MHz.

EN2	INV#	Q0	Q1	Q2	Q3	Q4	Q5
0	0	1X	1X	1X	1X	1X	1X
1	0	1X	1X	1X	1X	1X	0.5X
0	1	1X	1X	1X	0.5X	0.5X	1X
1	1	1X	1X	1X	0.5X	0.5X	0.5X

Example Table for AV9172-07

(66 MHz input, all frequencies in MHz.)

EN2	INV#	Q0	Q1	Q2	Q3	Q4	Q5
0	0	66	66	66	66	66	66
1	0	66	66	66	66	66	33
0	1	66	66	66	33	33	66
1	1	66	66	66	33	33	33

Timing Diagram for AV9172-07

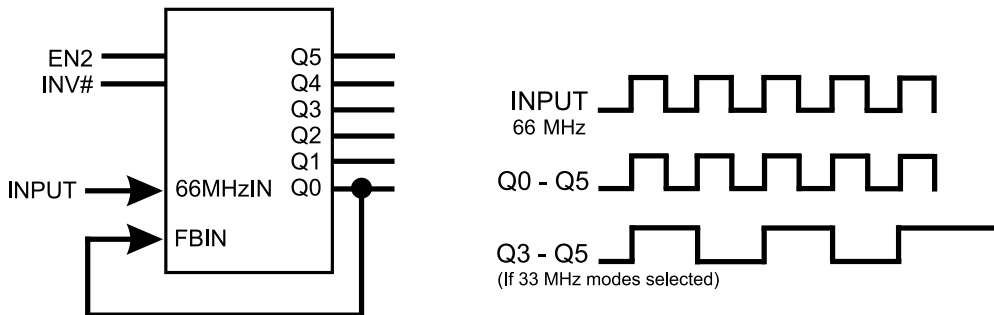

Absolute Maximum Ratings

- VDD referenced to GND 7V
- Operating temperature under bias 0°C to +70°C
- Storage temperature -65°C to +150°C
- Voltage on I/O pins referenced to GND. GND -0.5V to VDD +0.5V
- Power dissipation 0.5 Watts

Stresses above those listed under Absolute Maximum Ratings may cause permanent damage to the device. This is a stress rating only and functional operation of the device at these or any other conditions above those indicated in the operational sections of the specifications is not implied. Exposure to absolute maximum rating conditions for extended periods may affect product reliability.



AV9172

Electrical Characteristics

$V_{DD} = +5V \pm 5\%$, $T_A = 0^\circ C$ to $70^\circ C$ unless otherwise stated

DC Characteristics						
PARAMETER	SYMBOL	TEST CONDITIONS	MIN	TYP	MAX	UNITS
Input Low Voltage	V_{IL}	$V_{DD}=5V$	-	-	0.8	V
Input High Voltage	V_{IH}	$V_{DD}=5V$	2.0	-	-	V
Input Low Current	I_{IL}	$V_{IN}=0V$	-5	-	5	μA
Input High Current	I_{IH}	$V_{IN}=V$	-5	-	5	μA
Output Low Voltage	V_{OL}^*	$I_{OL}=25mA$	-	0.5	0.8	V
Output High Voltage	V_{OH}^*	$I_{OH}=-25mA$	2.4	-	-	V
Supply Current	I_{DD}	Unloaded, 50 MHz outputs	-	35	60	mA
AC Characteristics						
Input Clock Rise Time	$ICLK_r^*$		-	-	10	ns
Input Clock Fall Time	$ICLK_f^*$		-	-	10	ns
Output Rise time, 0.8 to 2.0V	t_r^*	15pF load	-	0.7	1	ns
Rise time, 20% to 80% V_{DD}	t_r^*	15pF load	-	1.2	2	ns
Output Fall time, 2.0 to 0.8V	t_f^*	15pF load	-	0.7	1	ns
Fall time, 80% to 20% V_{DD}	t_f^*	15pF load	-	1.2	2	ns
Output Duty cycle	d_t^*	15pF load	45	49/51	55	%
Jitter, 1 sigma	T_{1s}^*			60		ps
Jitter, absolute	T_{abs}^*			ae200		ps
Input Frequency (-01,-03)	f_i^*		10		50	MHz
Input Frequency (-07)	f_i^*		20		100	MHz
Output Frequency (-01,-03, -07)	f_o^*	Note 1	10		100	MHz
FBIN to IN skew	t_{skew1}^*	Note 2, 4. Input rise time < 3ns	-500	-300	500	ps
FBIN to IN skew	t_{skew1}^*	Note 2, 4. Input rise time < 10ns	1000	-500	1000	ps
Skew between any 2 outputs at same frequency	t_{skew2}^*	Note 2, 4	-250	± 50	250	ps
Skew between any 2 outputs at different frequencies		Note 2, 4			500	ps

*Parameter guaranteed by design and characterization. Not 100% tested in production.

Notes:

1. Output frequency includes both the Fast Clock (2X or 1X) and the Slow Clock (1X or 0.5X) extremes.
2. All skew specifications are measured with a 50W transmission line, load terminated with 50W to 1.4V.
3. Duty cycle measured at 1.4V.
4. Skew measured at 1.4V on rising edges. Loading must be equal on outputs.



Typical Performance Characteristics

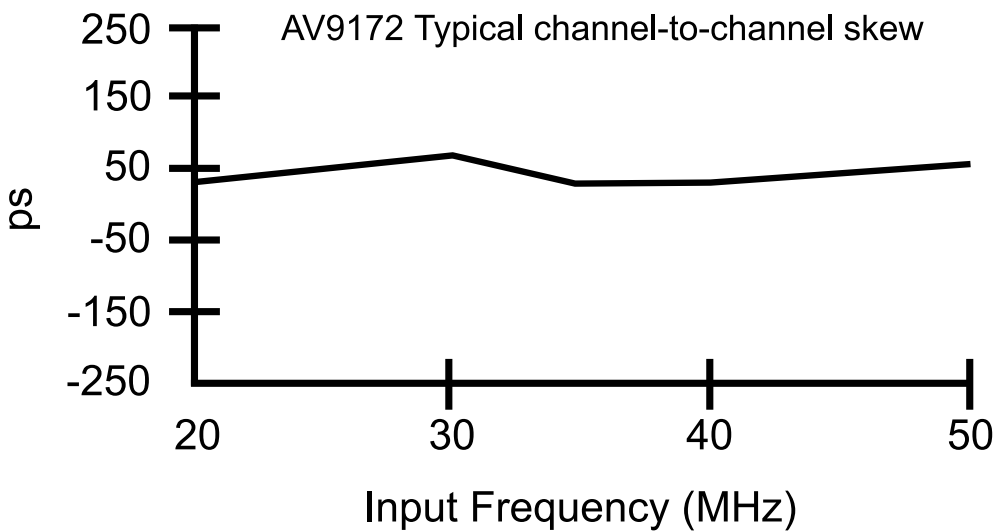
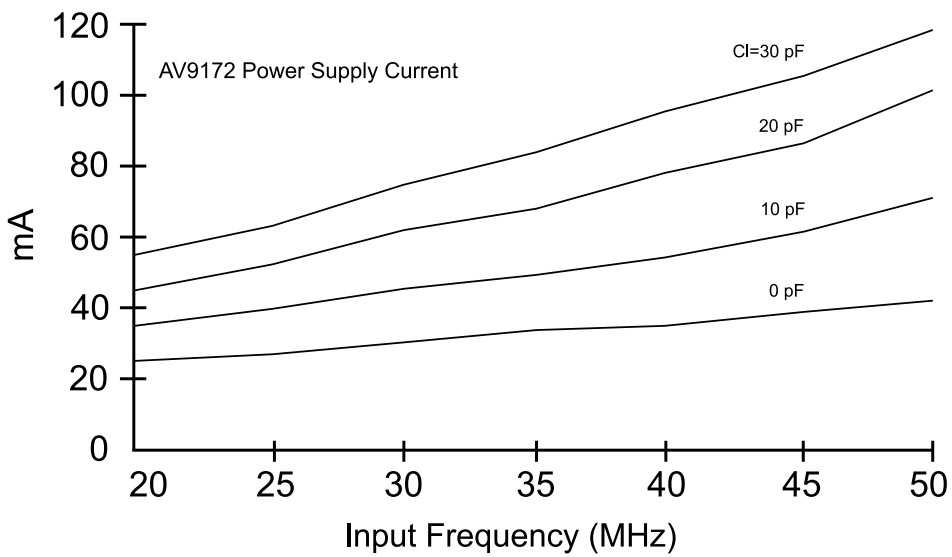



AV9172

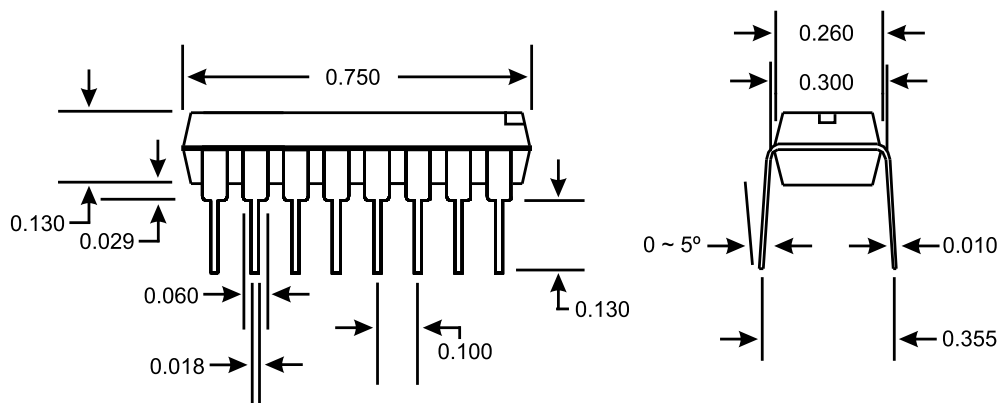

16-Pin PDIP Package

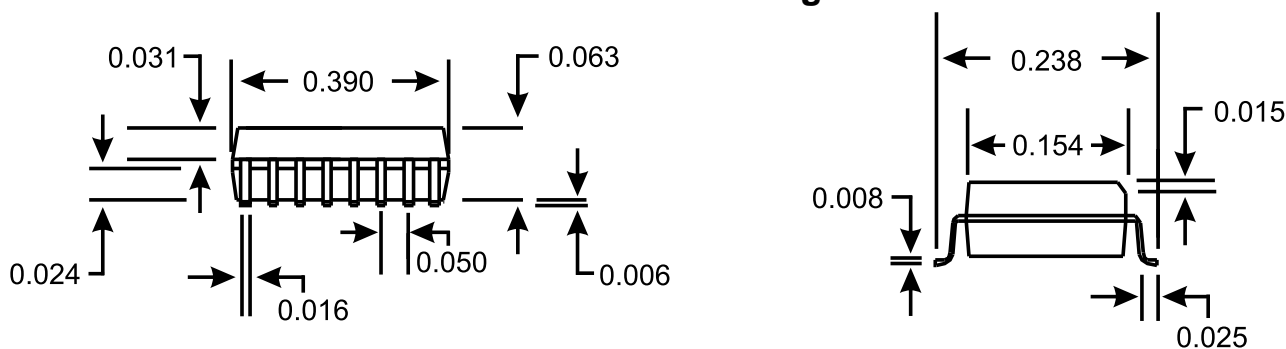

16-Pin SOIC Package

Ordering Information

Part Number	Part Marking	Temperature	Package Type
AV9172-xxCC16	AV9172-XX	0°C to 70°C	16 Lead CERDIP
AV9172-xxCN16	AV9172-XX	0°C to 70°C	16 Lead Plastic DIP (300 mil)
AV9172-xxCW16	AV9172-XX	0°C to 70°C	16 Lead SOIC (300 mil)
AV9172-xxCS16	AV9172-XX	0°C to 70°C	16 Lead SOIC (150 mil)

Example:

ICS XXXX-PPP M X#W

