



Frequency Generator for Multimedia Audio Synthesis

General Description

The ICS9120-08 and ICS 9120-09 are high performance frequency generators designed to support stereo audio codec systems. It offers both clock frequencies required by stereo codecs such as the CS4231 and the AD1848 plus the clock needed for the OPL4 FM synthesizer. These frequencies can be synthesized from the existing 14.318 MHz system clock or from the on-chip oscillator using a 14.318 MHz crystal (-08 only).

High accuracy, low jitter PLLs meet the 0.125% frequency tolerance and -96dB signal-to-noise ratios required by 16 bit audio systems. Fast output clock edge rates minimize board induced jitter.

Unlike competitive devices, the ICS9120-08 and ICS9120-09 operate over the entire 3.0-5.5V range, with the -09 providing power-down to minimize energy consumption.

Block Diagram

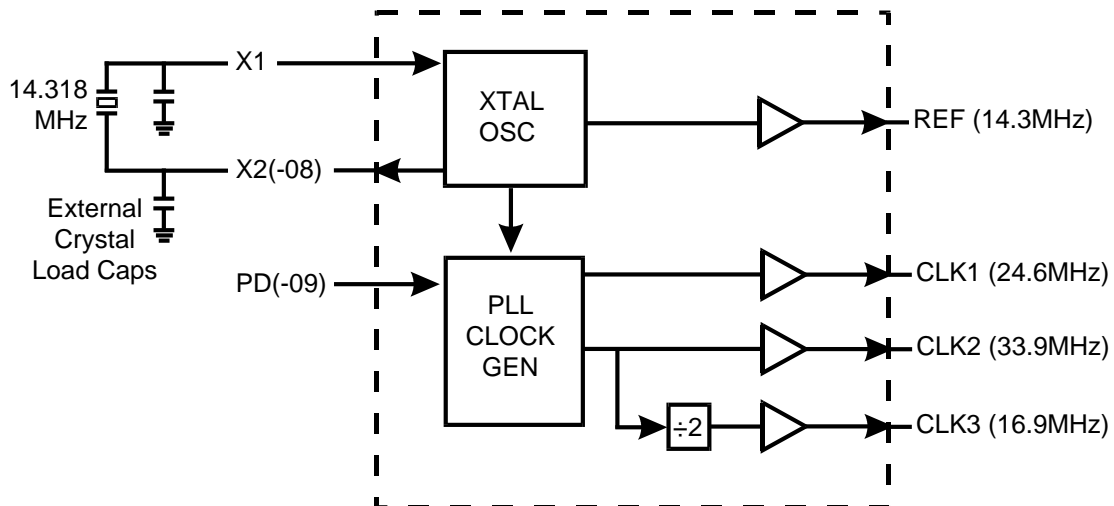

Features

- Generates 16.934 MHz and 24.576 MHz stereo codec clocks plus the 33.868 MHz OPL4 clock
- Single 14.318MHz crystal or system clock reference
- Buffered REFCLK output
- 0.125% frequency accuracy meets OPL4 specifications
- 100 ps one sigma jitter maintains 16 bit performance
- Output rise/fall times less than 2.0 nS
- On chip loop filter components
- 3.3V - 5 V supply range
- 8 pin, 150mil SOIC package

Applications

- Specifically designed to support the high performance requirements of multimedia audio systems.

ICS9120-08 ICS9120-09



Pin Configuration

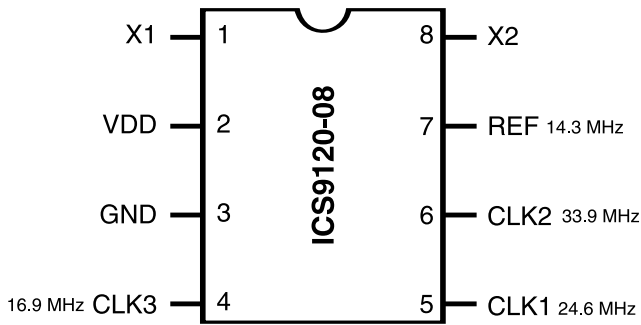

8-Pin SOIC

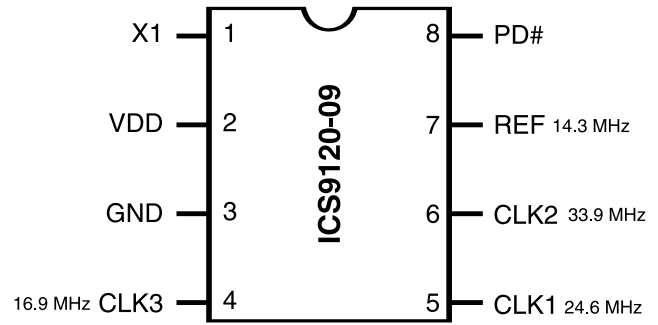

8-Pin SOIC

Functionality

X1, X2 (MHz)	(-09 only) PD#	33.9 (MHz)	16.9 (MHz)	24.6 (MHz)	14.3 (MHz)
-	0	Low	Low	Low	Low
14.318	1	33.868	16.934	24.576	14.318
-					

Note: (Pin 8) is internally pulled-up to V_{DD} and, therefore, may be left disconnected or driven by open collector logic.

Pin Descriptions for ICS9120-08

PIN NUMBER	PIN NAME	TYPE	DESCRIPTION
1	X1	Input	Crystal or external clock source. Has feedback bias for crystal.
2	V_{DD}	Power	Power supply input.
3	GND	Power	Ground return for Pin 2.
4	CLK3	Output	16.934 MHz target output clock for stereo codec.
5	CLK1	Output	24.576 MHz target output clock for stereo codec.
6	CLK2	Output	33.868 MHz target output clock for OPL4.
7	REF	Output	14.318 MHz reference clock buffered output.
8	X2	Output	Crystal output drive.

Pin Descriptions for ICS9120-09

PIN NUMBER	PIN NAME	TYPE	DESCRIPTION
1	X1	Input	External clock source.
2	V_{DD}	Power	Power supply input.
3	GND	Power	Ground return for Pin 2.
4	CLK3	Output	16.934 MHz target output clock for stereo codec.
5	CLK1	Output	24.576 MHz target output clock for stereo codec.
6	CLK2	Output	33.868 MHz target output clock for OPL4.
7	REF	Output	14.318 MHz reference clock buffered output.
8	$\overline{PD\#}$	Input	Power-down input powers down entire device when low; has pull-up.



Absolute Maximum Ratings

AVDD, VDD referenced to GND 7V
 Operating temperature under bias 0C to +70C
 Storage temperature -65C to +150
 Voltage on I/O pins referenced to GND GND -0.5V to VDD +0.5V
 Power dissipation 0.5 Watts

Stresses above those listed under Absolute Maximum Ratings may cause permanent damage to the device. This is a stress rating only and functional operation of the device at these or any other conditions above those indicated in the operational sections of the specifications is not implied. Exposure to absolute maximum rating conditions for extended periods may affect product reliability.

Electrical Characteristics at 3.3 V

V_{DD} = +3.0 to +3.7 V, T_A = 0 to 70°C unless otherwise stated

DC Characteristics						
PARAMETER	SYMBOL	TEST CONDITIONS	MIN	TYP	MAX	UNITS
Input Low Voltage	V _{IL}		-	-	0.2V _{DD}	V
Input High Voltage	V _{IH}		0.7V _{DD}	-	-	V
Input Low Current	I _{IL}	V _{IN} = 0 V (For -09 only)	-8.0	-3.6	-	μA
Input High Current	I _{IH}	V _{IN} (For -09 only)	-	-	5.0	μA
Output Low Voltage	V _{OL} *	I _{OL} = 6 mA	-	0.05V _{DD}	0.1	V
Output High Voltage	V _{OH} *	I _{OH} = -4.0 mA	0.85V _{DD}	0.94V _{DD}	-	V
Output Low Current	I _{OL} *	V _{OL} = 0.2V _{DD}	15.0	24.0	-	mA
Output High Current	I _{OH} *	V _{OH} = 0.7V _{DD}	-	-13.0	-8.0	mA
Supply Current	I _{CC}	Unloaded	-	13.0	32.0	mA
Supply Current	I _{CC(PD)}	Unloaded (For -09 only)	-	50.0	110.0	μA
Pull-up Resistor Value	R _{pu} *	(For -09 only)	-	620.0	900.0	k ohm

Note 1: Parameter is guaranteed by design and characterization. Not 100% tested in production.

ICS9120-08 ICS9120-09



Electrical Characteristics at 3.3 V

$V_{DD} = +3.0$ to $+3.7$ V, $T_A = 0$ - 70°C unless otherwise stated

AC Characteristics						
PARAMETER	SYMBOL	TEST CONDITIONS	MIN	TYP	MAX	UNITS
Rise Time	T_r^*	15pF load, 0.8 to 2.0V	-	1.5	4.0	ns
Fall Time	T_f^*	15pF load, 2.0 to 0.8V	-	1.0	3.0	ns
Rise Time	T_r^*	15pF load, 20% to 80%	-	2.2	4.0	ns
Fall Time	T_f^*	15pF load, 80% to 20%	-	1.5	3.0	ns
Duty Cycle	D_t^*	15pF load @ 50% of V_{DD} ; Except REFCLK	45.0	50.0	55.0	%
Duty Cycle	D_t^*	15pF load @ 50% of V_{DD} ; REFCLK only	40.0	45.0	60.0	%
Jitter, One Sigma	T_{jis}^*	For all frequencies except REFCLK	-	150.0	200	ps
Jitter, Absolute	T_{jab}^*	For all frequencies except REFCLK	-650.0	380.0	650.0	ps
Jitter, One Sigma	T_{jis}^*	REFCLK only	-	266.0	400.0	ps
Jitter, Absolute	T_{jab}^*	REFCLK only	-1000	750.0	1000	ps
Input Frequency	F_i^*		11.0	14.3	15.0	MHz
Output Frequency	F_o^*		11.0	-	38.0	MHz
Output Mean Frequency Accuracy vs. Target	F_{oa}^*	With 14.318 MHz input	-0.125	-	-0.04	%
Power-up Time	T_{pu}^*	0 to 33.8 MHz	-	5.5	12.0	ms
Crystal Input Capacitance	C_{inx}^*	X1 (Pin 1), X2 (Pin 8; -08 only)	-	5	-	pF

Note 1: Parameter is guaranteed by design and characterization. Not 100% tested in production.



Electrical Characteristics at 5.0 V

$V_{DD} = +4.5$ to $+5.5$ V, $T_A = 0-70^{\circ}\text{C}$ unless otherwise stated

DC Characteristics						
PARAMETER	SYMBOL	TEST CONDITIONS	MIN	TYP	MAX	UNITS
Input Low Voltage	V_{IL}		-	-	0.8	V
Input High Voltage	V_{IH}		2.0	-	-	V
Input Low Current	I_{IL}	$V_{IN} = 0\text{V}$ (For -09 only)	-18.0	-8.3	-	μA
Input High Current	I_{IH}	$V_{IN} = V_{DD}$ (For -09 only)	-	-	5.0	μA
Output Low Voltage	V_{OL}^*	$I_{OL} = 10$ mA	-	0.15	0.4	V
Output High Voltage	V_{OH}^*	$I_{OH} = -30$ mA	2.4	3.7	-	V
Output Low Current	I_{OL}^*	$V_{OL} = 0.8\text{V}$	25.0	45.0	-	mA
Output High Current	I_{OH}^*	$V_{OH} = 2.4\text{V}$	-	-53.0	-35.0	mA
Supply Current	I_{CC}	Unloaded	-	22.0	50.0	mA
Supply Current, Power-down	$I_{CC(PD)}$	Unloaded (For -09 only)	-	180.0	500.0	μA
Pull-up Resistor Value	R_{pu}^*	(For -09 only)	-	400.0	800.0	k ohm

Note 1: Parameter is guaranteed by design and characterization. Not 100% tested in production.

ICS9120-08 ICS9120-09



Electrical Characteristics at 5.0 V

$V_{DD} = 4.5 - 5.5 \text{ V}$, $T_A = 0 - 70^\circ\text{C}$ unless otherwise stated

AC Characteristics						
PARAMETER	SYMBOL	TEST CONDITIONS	MIN	TYP	MAX	UNITS
Rise Time	T_r^*	15pF load, 0.8 to 2.0V	-	0.9	2.0	ns
Fall Time	T_f^*	15pF load, 2.0 to 0.8V	-	0.7	1.5	ns
Rise Time	T_r^*	15pF load, 20% to 80%	-	1.8	3.25	ns
Fall Time	T_f^*	15pF load, 80% to 20%	-	1.4	2.5	ns
Duty Cycle	D_t^*	15pF load @ 50% of V_{DD} ; Except REFCLK	45.0	50.0	55.0	%
Duty Cycle	D_t^*	15pF load @ 50% of V_{DD} ; REFCLK only	40.0	50.0	60.0	%
Jitter, One Sigma	T_{jis}^*	For all frequencies except REFCLK	-	100.0	150.0	ps
Jitter, Absolute	T_{jab}^*	For all frequencies except REFCLK	-600.0	380.0	600.0	ps
Jitter, One Sigma	T_{jis}^*	REFCLK only	-	266.0	450.0	ps
Jitter, Absolute	T_{jab}^*	REFCLK only	-1200	750.0	1200	ps
Input Frequency Range	F_i^*		11.0	14.0	17.0	MHz
Output Frequency Range	F_o^*		11.0	-	42.0	MHz
Output Mean Frequency Accuracy vs. Target	F_{oa}^*	With 14.318 MHz input	-0.125	-	-0.04	%
Power-up Time	T_{pu}^*	0 to 33.8 MHz	-	5.5	12.0	ms
Crystal Input Capacitance	C_{inx}^*	X1 (Pin 1), X2 (Pin 8; -08 only)	-	5	-	pF

Note 1: Parameter is guaranteed by design and characterization. Not 100% tested in production.

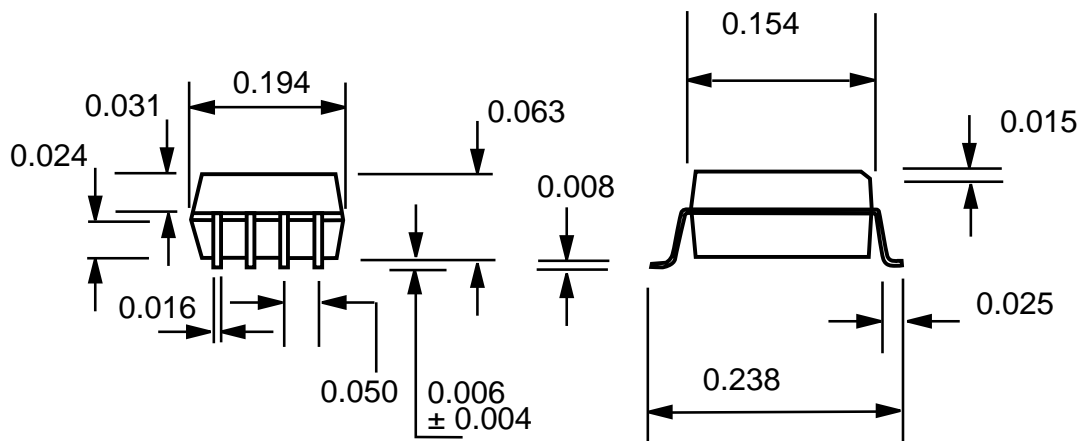

8-Pin SOIC Package

Ordering Information

ICS9120M-08, ICS9120M-09

Example:

ICS XXXX M-PPP

