

## 32 KhZ Motherboard Frequency Generator

### General Description

The **ICS9131** offers a tiny footprint solution for generating a selectable CPU clock from a 32.768 kHz crystal. The device allows a variety of microprocessors to be clocked by changing the state of address lines FS0, FS1, and FS2. The **ICS9131** is the ideal solution for replacing high speed oscillators and for reducing clock speeds to save power in computers. The device provides smooth, glitch-free frequency transitions so that the CPU can continue to operate during slow down or speed up. The rate of frequency change makes the **ICS9131** compatible with all 386DX, 386SX, 486DX, 486DXZ, 486SX and Pentium™ microprocessors.

The **ICS9131** is driven from a single 32.768 kHz crystal. The only external components required are the crystal and a 10M ohm resistor. The device generates the 14.318 MHz system clock, eliminating the need for a 14.318 MHz crystal. High-Performance applications may require high speed clock termination components.

### VDD32 Supply

The **ICS9131** has a separate power supply for the 32.768 kHz oscillator circuitry. This allows the 32 kHz clock to run from a battery or other source while the main power to the chip is disconnected. The VDD32 supply is guaranteed to operate down to +2.0V, with the clock consuming less than 10µA at +3.3V and the main VDD at 0V.

The frequencies and power-down options in the **ICS9131** are mask programmable. Customer specific masks can be made and prototypes delivered within 6-8 weeks from receipt of order. ICS also offers standard versions, such as those described in this data sheet.

### Features

- Single 32.768 kHz crystal generates system clock and selectable CPU clock
- Generates CPU clocks from 8 MHz to 100 MHz.
- Operates from 3.3V or 5.0V supply
- Operates up to 66 MHz at 3.3V
- Separate VDD for 32 kHz clock enables it to run from battery
- STOPCLK feature allows for a glitch-free turn-on and Pen-turn-off of the CPU clock to static processors
- Output enable tristates outputs
- 16-pin PDIP or SOIC package
- Frequency selects allow for a smooth transition of the CPUCLK

### Pin Configuration

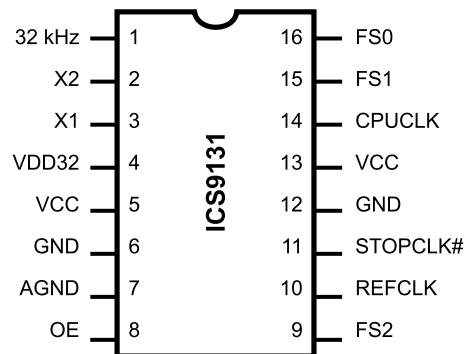

**16-Pin DIP or SOIC**

### Block Diagram

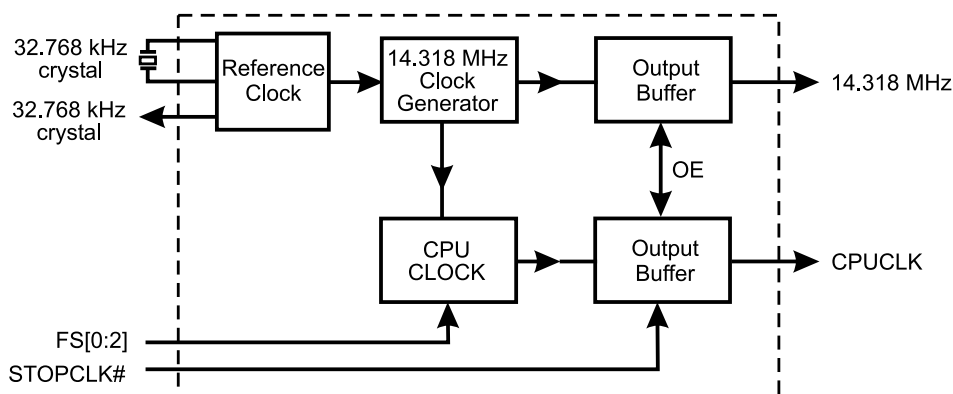

Pentium is a trademark of Intel.



# ICS9131

## Pin Descriptions

PIN NUMBER	PIN NAME	TYPE	DESCRIPTION
1	32 kHz	Output	32.768 kHz output.
2	X2	Output	Connect 32 kHz crystal, this input includes internal load capacitor for crystal.
3	X1	Input	Connect 32 kHz crystal, this input includes internal load capacitor for crystal.
4	VDD32	--	Power Supply for 32 kHz oscillator.
5	VCC	--	Power Supply.
6	VSS	--	Ground.
7	AGND	--	Analog Ground.
8	OE	Input	OE tristates outputs when low.
9	FS2	Input	CPU clock frequency select 2.
10	REFCLK	Output	14.318 MHz output.
11	STOPCLK#	Input	Stops CPU clock when low.
12	VSS	--	Ground.
13	VCC	--	Power supply.
14	CPUCLK	Output	CPU clock output (see Decoding table).
15	FS1	Input	CPU clock frequency select 1.
16	FS0	Input	CPU clock frequency select 0.

## Functionality

FS2	FS1	FS0	CPUCLK	ACTUALS
0	0	0	16	16.004
0	0	1	25	25.059
0	1	0	33.3	33.412
0	1	1	40	40.095
1	0	0	50	50.119
1	0	1	60	60.142
1	1	0	66.6	66.484
1	1	1	80	80.190



Recommended External Circuit

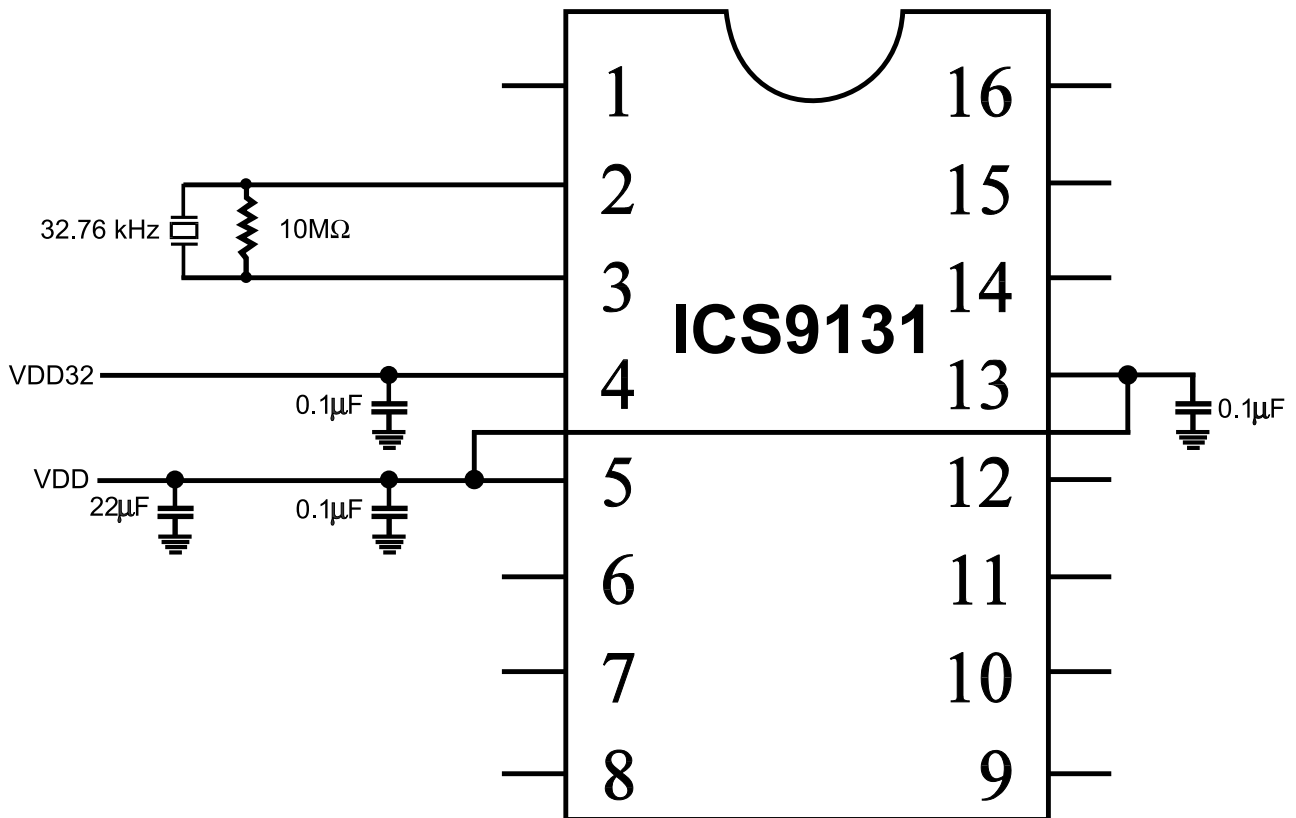

Notes:

- 1) The external components shown should be placed as close to the device as possible.
- 2) Pins 5 and 13 should be connected together externally. One decoupling capacitor may suffice for both pins.



# ICS9131

## Absolute Maximum Ratings

VDD referenced to GND . . . . . 7V  
 Operating temperature under bias. . . . . 0°C to +70°C  
 Storage temperature . . . . . -40°C to +150°C  
 Voltage on I/O pins referenced to GND. . . . . GND -0.5V to VDD +0.5V  
 Power dissipation . . . . . 0.5 Watts

Stresses above those listed under Absolute Maximum Ratings may cause permanent damage to the device. This is a stress rating only and functional operation of the device at these or any other conditions above those indicated in the operational sections of the specifications is not implied. Exposure to absolute maximum rating conditions for extended periods may affect product reliability.

## Electrical Characteristics at 5V

Operating V<sub>DD</sub> = +4.5V to +5.5V; T<sub>A</sub> =0°C to 70°C unless otherwise stated

DC Characteristics						
PARAMETER	SYMBOL	TEST CONDITIONS	MIN	TYP	MAX	UNITS
Input Low Voltage	V <sub>IL</sub>		-	-	0.8	V
Input High Voltage	V <sub>IH</sub>		2.0	-	-	V
Input Low Current	I <sub>IL</sub>	V <sub>IN</sub> =0V	-15.0	-6.0		μA
Input High Current	I <sub>IH</sub>	V <sub>IN</sub> =V <sub>DD</sub>	-2.0	-	2.0	μA
Pull-up Resistor, Note 1	R <sub>pu</sub>	V <sub>IN</sub> =V <sub>DD</sub> -1V	-	400	700	k ohms
Output Low Current, Note 1	I <sub>OL</sub>	V <sub>OUT</sub> =0.8V	25	45	-	mA
Output High Current, Note 1	I <sub>OH</sub>	V <sub>OUT</sub> =2.0V	-	-53	-35	mA
Output Low Voltage	V <sub>OL</sub>	I <sub>OL</sub> =10mA	-	0.15	0.4	V
Output High Voltage, Note 1	V <sub>OH</sub>	I <sub>OH</sub> =-30mA	2.4	3.7	-	V
Supply Current	I <sub>DD</sub>	No load, at 50 MHz	-	18	35	mA
Output Frequency Change over Supply and Temperature, Note 1	F <sub>d</sub>	With respect to typical frequency	-	0.002	0.05	%
Standby Supply Current, Note 2	I <sub>DDSTDBY</sub>	Unloaded	-	12	25	mA

Note 1: Parameter is guaranteed by design and characterization. Not 100% tested in production.

Note 2: With the STOPCLK pin low (active).

Note 3: Absolute Jitter measured as the shortest and longest period difference to the mean period of the sample set.



## Electrical Characteristics at 5V

Operating  $V_{DD} = +4.5V$  to  $+5.5V$ ;  $T_A = 0^{\circ}C$  to  $70^{\circ}C$  unless otherwise stated

AC Characteristics						
PARAMETER	SYMBOL	TEST CONDITIONS	MIN	TYP	MAX	UNITS
Output Frequency, Note 1	$f_o$	Clock1	12.0	-	100	MHz
Input Frequency, Note 1	$f_i$		2.0	32	38	kHz
Output Rise time, Note 1	$t_r$	15pF load, 0.8 to 2.0V	-	0.60	1.4	ns
Rise time, Note 1	$t_r$	15pF load, 20% to 80% $V_{DD}$	-	1.6	3.0	ns
Output Fall time, Note 1	$t_f$	15pF load, 2.0 to 0.8V	-	0.50	1.2	ns
Fall time, Note 1	$t_f$	15pF load, 80% to 20% $V_{DD}$	-	0.9	2.5	ns
Duty cycle, Note 1	$d_t$	15pF load @1.4V	45	50	55	%
Jitter, 1 sigma from 33-80 MHz, Note 1	$T_{jis}$	10,000 samples	-	50	150	ps
Jitter, Absolute from 33-80 MHz, Notes 1, 3	$T_{jabs}$	10,000 samples	-250	-	250	ps
Jitter, 1 sigma from 16-25 MHz, Note 1	$T_{jis}$	10,000 samples		60	150	ps
Jitter, Absolute from 16-25 MHz, Note 1, 3	$T_{jabs}$	10,000 samples	-600	-	600	ps
Jitter, 1 sigma from 14 to below, Note 1	$T_{jis}$	10,000 samples	-	1	3	%
Jitter, Absolute from 14 to below, Note 1, 3	$T_{jabs}$	10,000 samples	-	2	5	%
Frequency Transition time, Note 1	$t_{ft}$		2.0	5.0	10.0	ms
Power-up time, Note 1	$t_{pu}$		3.0	7.5	15	ms

Note 1: Parameter is guaranteed by design and characterization. Not 100% tested in production.

Note 2: With the STOPCLK pin low (active).

Note 3: Absolute Jitter measured as the shortest and longest period difference to the mean period of the sample set.



# ICS9131

## Electrical Characteristics at 3.3V

Operating  $V_{DD} = +3.3V$  to  $+3.7V$ ;  $T_A = 0^{\circ}C$  to  $70^{\circ}C$  unless otherwise stated

DC Characteristics						
PARAMETER	SYMBOL	TEST CONDITIONS	MIN	TYP	MAX	UNITS
Input Low Voltage	$V_{IL}$		-	-	$0.2 V_{DD}$	V
Input High Voltage	$V_{IH}$		$0.7 V_{DD}$	-	-	V
Input Low Current	$I_{IL}$	$V_{IN}=0V$	-7.0	-2.5		$\mu A$
Input High Current	$I_{IH}$	$V_{IN}=V_{DD}$	-2.0	-	2.0	$\mu A$
Pull-up Resistor, Note 1	$R_{pu}$	$V_{IN}=V_{DD}-1V$	-	600	900	k ohms
Output Low Current, Note 1	$I_{OL}$	$V_{OUT}=0.2V$	15	24	-	mA
Output High Current, Note 1	$I_{OH}$	$V_{OUT}=0.7V$	-	-13	-8	mA
Output Low Voltage, Note 1	$V_{OL}$	$I_{OL}=60mA$	-	$0.05 V_{DD}$	$0.1 V_{DD}$	V
Output High Voltage, Note 1	$V_{OH}$	$I_{OH}=-4.0mA$	$6.85 V_{DD}$	$0.94 V_{DD}$	-	V
Supply Current	$I_{DD}$	No load, at 50 MHz	-	13	25	mA
Output Frequency Change over Supply and Temperature, Note 1	$F_d$	With respect to typical frequency	-	0.002	0.05	%
Standby Supply Current, Note 2	$I_{DDSTDBY}$	No load	-	8	15	mA
AC Characteristics						
Output Frequency, Note 1	$f_o$	Clock1	12.0	-	100	MHz
Input Frequency, Note 1	$f_i$		2.0	32	38	kHz
Rise time, Note 1	$t_r$	15pF load, 20% to 80% $V_{DD}$	-	2.2	3.5	ns
Fall time, Note 1	$t_f$	15pF load, 80% to 20% $V_{DD}$	-	1.2	2.5	ns
Duty cycle, Note 1	$d_t$	15pF load @50% $V_{DD}$	43	-	53	%
Jitter, 1 sigma , Note 1	$T_{jiss}$	10,000 samples	-	50	150	ps
Jitter, Absolute, Note 1, 3	$T_{jabs}$	10,000 samples	-250		250	ps
Jitter, 1 sigma from 16-25 MHz	$T_{jiss}$	10,000 samples	-	60	150	ps
Jitter, Absolute from 16-25 MHz	$T_{jabs}$	10,000 samples	-600	-	600	ps
Jitter, 1 sigma from 14 to below	$T_{jiss}$	10,000 samples	-	1	3	%
Jitter, Absolute from 14 to below	$T_{jabs}$	10,000 samples	-	2	5	%
Frequency Transition time, Note 1	$t_{ft}$			6.7	14.0	ms
Power-up time, Note 1	$t_{pu}$		-	8.55	17.0	ms

Note 1: Parameter is guaranteed by design and characterization. Not 100% tested in production.

Note 2: With the STOPCLK pin low (active).

Note 3: Absolute Jitter measured as the shortest and longest period difference to the mean period of the sample set.



### Stop Clock Feature

The ICS9131 incorporates a unique stop clock feature compatible with static logic processors. When the stop clock pin goes low, the CPUCLK will go low after the next occurring falling edge. When STOPCLK again goes high, CPUCLK resumes on the next rising edge of the internal clock. This feature enables fast, glitch-free starts and stops of the CPUCLK and is useful in Energy Star motherboard applications.

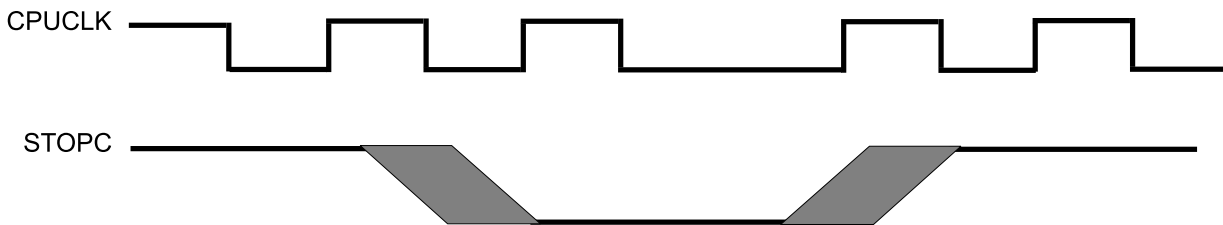

### 32 kHz Supply Current

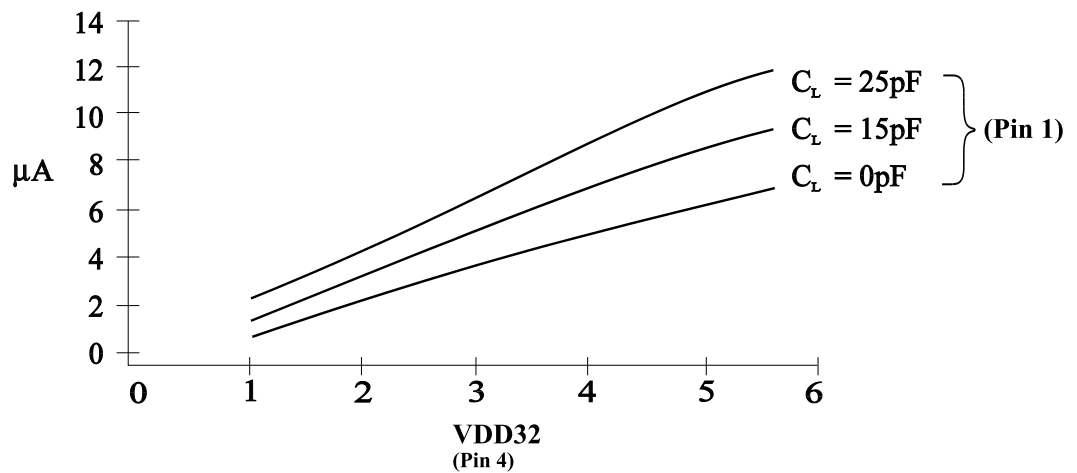

ADVANCE INFORMATION documents contain information on new products in the sampling or preproduction phase of development. Characteristic data and other specifications are subject to change without notice.



# ICS9131

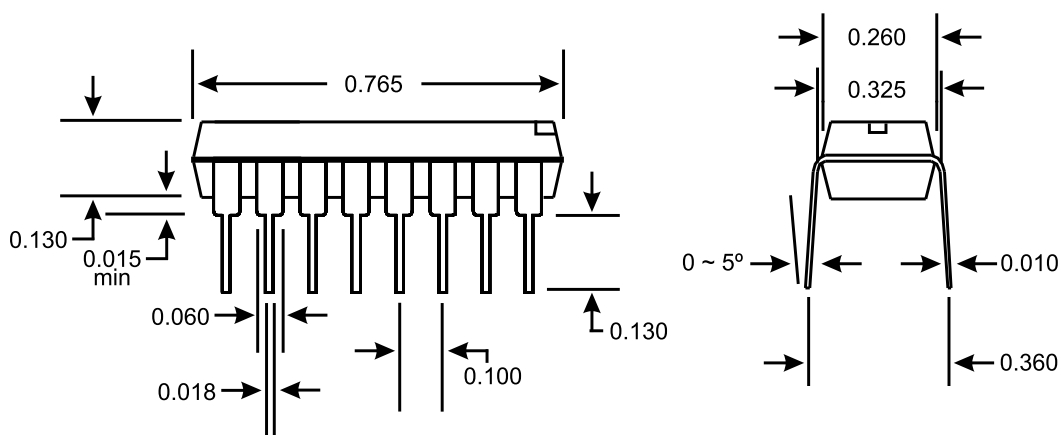

**16-Pin DIP Package**

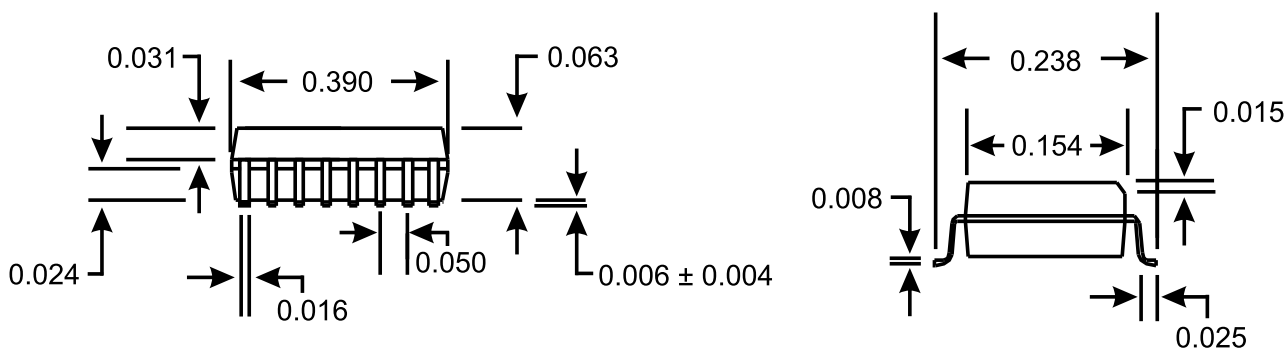

**16-Pin SOIC Package**

## Ordering Information

ICS9131-01CN16 or ICS9131-01CS16

Example:

**ICS XXXX M X#W**

