



ICS581-01, -02 Zero-Delay Glitch-Free Clock Multiplexer

Description

The ICS581-01 and ICS581-02 are glitch free, Phase Locked Loop (PLL) based clock multiplexers (mux) with zero delay from input to output. They each have 4 low skew outputs which can be configured as a single output, 3 outputs or 4 outputs. The ICS581-01 allows user control over the mux switching. The ICS581-02 has automatic switching between the 2 clock inputs.

The ICS581-01 and -02 are members of the ICS Clock Blocks™ family of clock generation, synchronization, and distribution devices. For a non-PLL based clock mux, see the ICS580-01.

Features



- Tiny 16 pin TSSOP package
- No short pulses or glitches on output. Operates to 200 MHz
- User controlled (ICS581-01) or automatic, timed (ICS581-02) switch
- Low skew outputs
- Ideal for systems with backup or redundant clocks
- Zero delay, input to output
- 50% output duty cycle allows duty cycle correction
- Spread Smart™ technology works with spread spectrum parts

Block Diagrams

ICS581-01

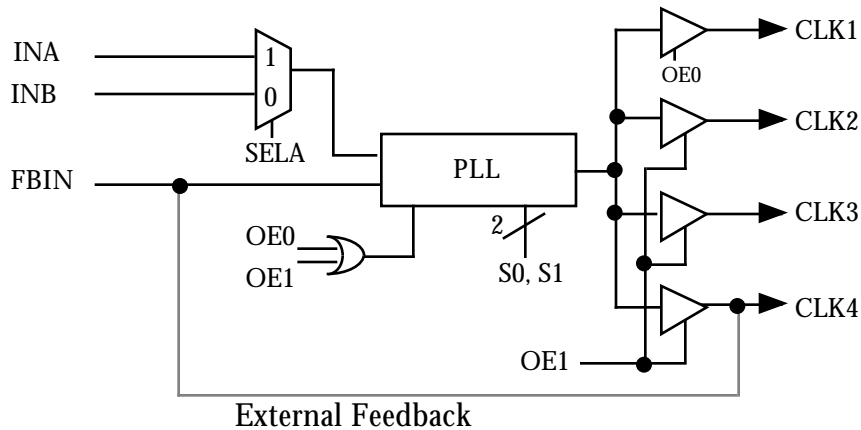

ICS581-02

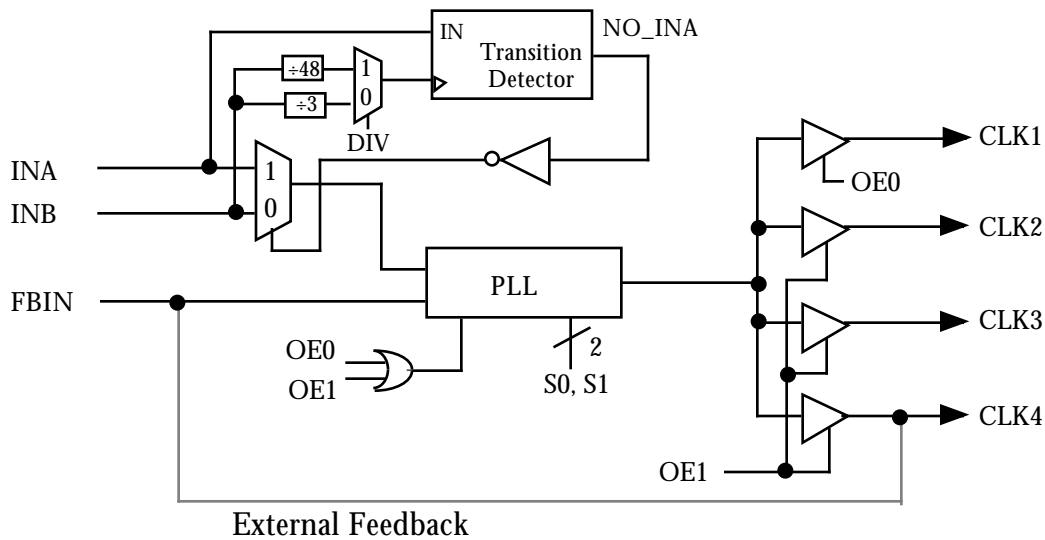



ICS581-01, -02

Zero-Delay Glitch-Free Clock Multiplexer

Pin Assignment

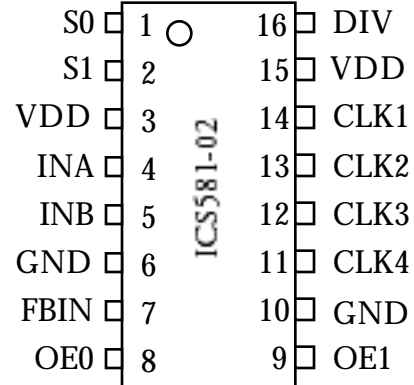
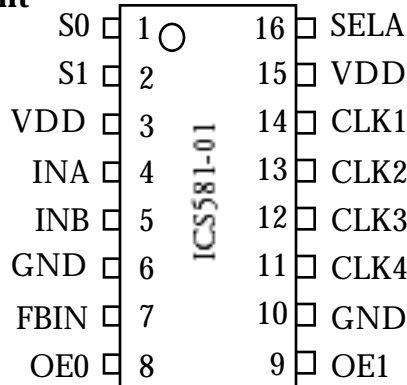

Clock Decoding

SELA	CLK1:4
0	INB
1	INA

ICS581-01 only

Timeout Selection

DIV	Nominal Timeout
0	3xPeriod of INB
1	48xPeriod of INB

ICS581-02 only

Tri-State and Power Down

OE1	OE0	CLK1	CLK2,3,4	PLL
0	0	Z	Z	Off
0	1	On	Z	On
1	0	Z	On	On
1	1	On	On	On

ICS581-01,-02

Frequency Range Select

S1	S0	Input Range (MHz)
0	0	50-150
0	1	19-75
1	0	6-19
1	1	150-200

ICS581-01,-02

Pin Descriptions

Number	Name	Type	Chip	Description
1	S0	I	-01, -02	Select 0 for frequency range. See table. Internal pull-up.
2	S1	I	-01, -02	Select 1 for frequency range. See table. Internal pull-up.
3	VDD	P	-01, -02	Connect to +3.3 V or + 5 V.
4	INA	I	-01, -02	Input Clock A.
5	INB	I	-01, -02	Input Clock B.
6	GND	P	-01, -02	Connect to ground.
7	FBIN	I	-01, -02	Feedback input. Connect to a clock output.
8	OE0	I	-01, -02	Output Enable0. See Table. Internal pull-up.
9	OE1	I	-01, -02	Output Enable1. See Table. Internal pull-up.
10	GND	P	-01, -02	Connect to ground.
11	CLK4	O	-01, -02	Low skew clock output.
12	CLK3	O	-01, -02	Low skew clock output.
13	CLK2	O	-01, -02	Low skew clock output.
14	CLK1	O	-01, -02	Low skew clock output.
15	VDD	P	-01, -02	Connect to +3.3 V or + 5 V.
16	SELA	I	-01 only	Mux select. Selects INA when high. Internal pull-up.
16	DIV	I	-02 only	Timeout select. See table. Internal pull-up.

Key: I = Input; O = output; P = power supply connection



ICS581-01, -02

Zero-Delay Glitch-Free Clock Multiplexer

Device Operation

The ICS581-01 and ICS581-02 are very similar. The following describes the operation of the ICS581-01, and then the differences of the ICS581-02 will be discussed.

The ICS581-01 is a PLL based, zero delay, clock multiplexer. The device consists of an input multiplexer controlled by SELA that selects between 2 clock inputs. The output of the mux drives the reference input of a phase-locked loop. The other input to the PLL comes from a feedback input pin called FBIN. The output of the PLL drives 4 low skew outputs. These chip outputs are therefore buffered versions of the selected input clock with zero delay and 50/50 duty cycle.

For correct operation, one of the clock outputs must be connected to FBIN. In this datasheet, CLK4 is shown as the feedback, but any of the 4 clock outputs can be used. If output termination resistors are used, the feedback should be connected after the resistor. It is a property of the PLL used on this chip that it will align rising edges on FBIN and either INA or INB (depending on SELA). Since FBIN is connected to a clock output, this means that the outputs appear to align with the input with zero delay.

When the input select (SELA) is changed, the output clock will change frequency and/or phase until it lines up with the new input clock. This occurs in a smooth, gradual manner without any short pulses or glitches, and will typically take a few tens of microseconds.

The part must be configured to operate in the correct frequency range. The Table on page 2 gives the recommended range.

The 4 low skew outputs are controlled by 2 output enable pins that allow either 1, 3 or 4 simultaneous outputs. If both OE pins are low, the PLL is powered down. Note that the clock driving the FBIN pin must not be tri-stated unless the PLL is powered down, otherwise the PLL will run open loop.

The ICS581-02 is identical to the ICS581-01 except for the switching of the input mux. On the ICS581-02, the switching is automatically controlled by a transition detector. The transition detector monitors the clock on INA. If this clock stops, the output of the detector, NO_INA, goes high which then selects clock input INB to the mux. The definition of the clock stopping is determined by a timeout selected by input DIV. If DIV is low, NO_INA will go high after no transitions have occurred on INA for nominally 3 cycles of the clock on INB. If DIV is high the timeout is nominally 48 cycles of INB. When INA restarts, the mux immediately switches back to the INA selection with no timeout.

Input Clock Frequency

The ICS581-01 and 02 are designed to switch between 2 clocks of the same frequency. They will also operate with different frequencies on each of the 2 input clocks. If the 2 input frequencies require different input ranges, (table on page 2) then the highest range should be permanently selected. When the selected input clock is outside this range, jitter and input skew specifications may not be met. Consult ICS for more information.



ICS581-01, -02 Zero-Delay Glitch-Free Clock Multiplexer

Application Example

A typical application for the ICS581-02 is to provide a backup clock for a system. The backup, reliable clock would be connected to INB while the main clock would be connected to INA. If the main clock failed, the backup clock would automatically be switched in. The following example shows the connection for this.

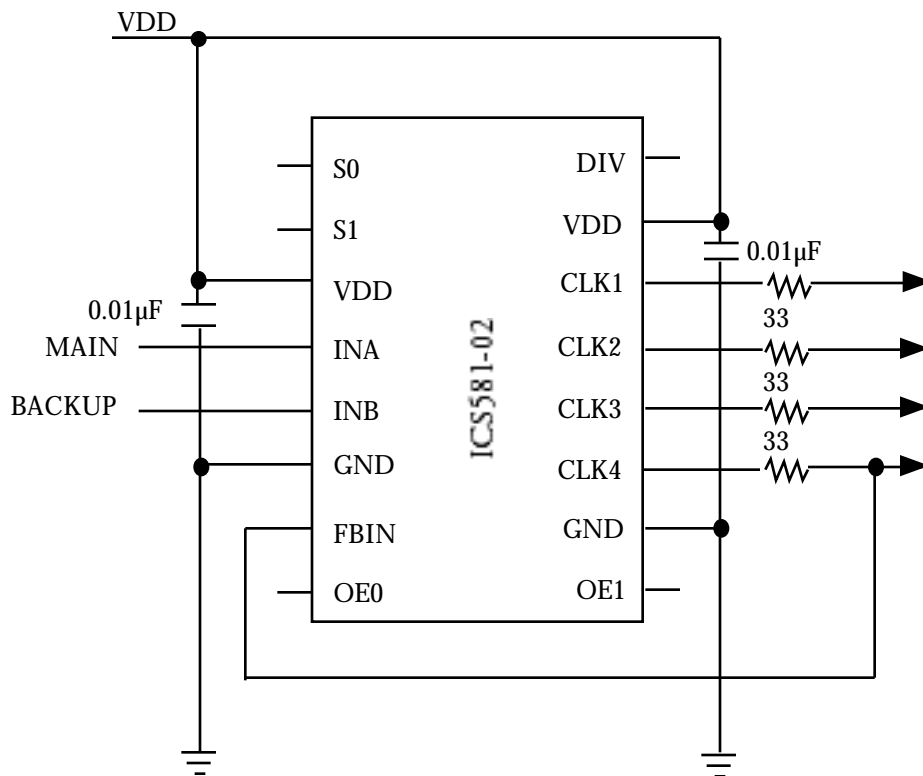

In this example, the clocks are 155 MHz and so the frequency range is address 11. Both S0 and S1 are left unconnected and so the on-chip pull-ups give the required high inputs. Similarly for OE0, OE1 and DIV. In this example, CLK4 is used as the feedback.

External Components

The ICS581-01 and -02 require two 0.01 µF capacitors between VDD and GND, one on each side of the chip. These must be close to the chip to minimize lead inductance. Series termination resistors of 33 Ω can be used on the outputs. These also should be close to the chip, with the feedback connection after the resistor.



ICS581-01, -02

Zero-Delay Glitch-Free Clock Multiplexer

Electrical Specifications

Parameter	Conditions	Minimum	Typical	Maximum	Units
ABSOLUTE MAXIMUM RATINGS					
Supply voltage, VDD	Referenced to GND			7	V
Inputs and Clock Outputs	Referenced to GND	-0.5		VDD+0.5	V
Ambient Operating Temperature		0		70	°C
	ICS581G-01I	-40		85	°C
Soldering Temperature	Max of 10 seconds			260	°C
Storage temperature		-65		150	°C
DC CHARACTERISTICS (VDD = 3.3 V unless noted)					
Operating Voltage, VDD		3.0		5.5	V
Input High Voltage, VIH	INA and INB only	(VDD/2)+1	VDD/2		V
Input Low Voltage, VIL	INA and INB only		VDD/2	(VDD/2)-1	V
Input High Voltage, VIH	Non-clock inputs	2			V
Input Low Voltage, VIL	Non-clock inputs			0.8	V
Output High Voltage, VOH	IOH=-12mA	VDD-0.5			V
Output Low Voltage, VOL	IOL=12mA			0.5	V
Operating Supply Current, IDD	100 MHz inputs, no Load		26		mA
Short Circuit Current			±70		mA
On-chip pull-up resistor			250		k
Input Capacitance			4		pF
AC CHARACTERISTICS (VDD = 3.3 V unless noted)					
Input Frequency	Note 6	6		200	MHz
Input Clock Duty Cycle	at VDD/2	30		70	%
Skew, selected input clock to FBIN	Note 1	-250	0	250	ps
Skew, between any output clocks	Note 2	-250	0	250	ps
Transition Detector Timeout, DIV=0	ICS581-02 only	2	3	4	INB periods
Transition Detector Timeout, DIV=1	ICS581-02 only	32	48	64	INB periods
Frequency Transition Time, 50 to 150 MHz	Note 3, 4		70	200	µs
Frequency Transition Time, 100 to 100 MHz	Note 3, 5		4	10	µs
Output Clock Rise Time	0.8 V to 2 V		1	2	ns
Output Clock Fall Time	2 V to 0.8 V		1	2	ns
Output Clock Duty Cycle, less than 133 MHz	at VDD/2, no load	45		55	%
Output Clock Duty Cycle, greater than 133 MHz	at VDD/2, no load	40		60	%
Output Clock Duty Cycle with S0=S1=1	at VDD/2, no load	40		60	%
Absolute Output Clock Period Jitter	Deviation from mean		±150		ps
One Sigma Output Clock Period Jitter			40		ps

Note 1. Assumes clocks with same rise times, measured at VDD/2.

Note 2. Assumes identically loaded outputs with identical rise times, measured at VDD/2.
The maximum skew between any 2 clocks is 250 ps not 500 ps.

Note 3. Time taken for output to lock to new clock when mux selection changed from INA to INB.

Note 4. With 50 MHz on INA and 150 MHz on INB.

Note 5. With 100 MHz on both INA and INB, 180° out of phase.

Note 6. For correct operation, FBIN requires a rail to rail clock. At high frequencies, this may mean that the ICS581 output driving FBIN cannot drive other loads.



ICS581-01, -02

Zero-Delay Glitch-Free Clock Multiplexer

Package Outline and Package Dimensions

(For current dimensional specifications, see JEDEC Publication No. 95.)

16 pin TSSOP

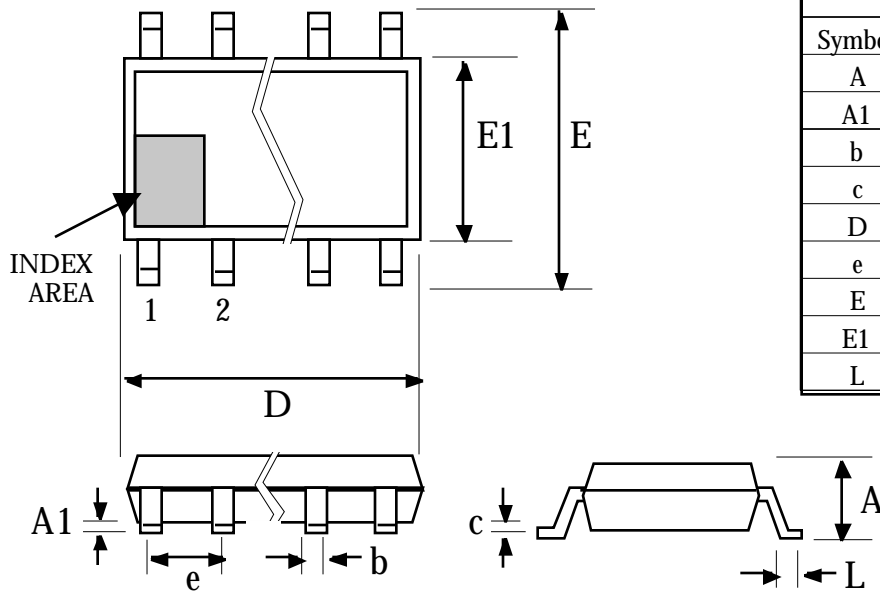

Symbol	Inches		Millimeters	
	Min	Max	Min	Max
A	--	0.047	--	1.19
A1	0.002	0.006	0.05	0.15
b	0.007	0.012	0.18	0.30
c	0.0035	0.008	0.09	0.20
D	0.193	0.201	4.90	5.11
e	.025 BSC		0.65 BSC	
E	.252 BSC		6.40 BSC	
E1	0.169	0.177	4.29	4.50
L	0.018	0.030	0.46	0.76

Ordering Information

Part/Order Number	Marking	Shipping, packaging	Package	Temperature
ICS581G-01	ICS581G-01	tubes	16 pin TSSOP	0 to 70 °C
ICS581G-01T	ICS581G-01	tape and reel	16 pin TSSOP	0 to 70 °C
ICS581G-02	ICS581G-02	tubes	16 pin TSSOP	0 to 70 °C
ICS581G-02T	ICS581G-02	tape and reel	16 pin TSSOP	0 to 70 °C
ICS581G-01I	ICS581G-01I	tubes	16 pin TSSOP	-40 to 85°

While the information presented herein has been checked for both accuracy and reliability, Integrated Circuit Systems, Incorporated (ICS) assumes no responsibility for either its use or for the infringement of any patents or other rights of third parties, which would result from its use. No other circuits, patents, or licenses are implied. This product is intended for use in normal commercial applications. Any other applications such as those requiring extended temperature range, high reliability, or other extraordinary environmental requirements are not recommended without additional processing by ICS. ICS reserves the right to change any circuitry or specifications without notice. ICS does not authorize or warrant any ICS product for use in life support devices or critical medical instruments.