



Description

The MK2042-01 is designed to switch between two clock sources. The switching can be externally controlled by an input pin or configured to switch automatically if the primary input clock stops. The part also provides clock detection by reporting when the primary input clock has stopped.

The MK2042-01 is optimized for use with our MK2049 family of Communication Clock Synthesizers. When used together, the MK2042-01 and MK2049 provide a complete system for switching to an alternate source when the primary clock is lost, or for maintaining a stable frequency on the MK2049 output.

For switching between clock sources with no output glitches or short pulses, use the ICS580 or ICS581 multiplexers.

Features

- Packaged in 16 pin SOIC 
- User controlled or automatic switching
- Clock detect feature
- Does not add jitter or phase noise to the clock
- Ideal for systems with backup or redundant clocks
- Selectable timeouts for clock loss detection
- Accepts input frequencies from 0 Hz to 160 MHz
- Works with all MK2049-xx to provide enhanced operation
- 3.3 V or 5 V operation

Block Diagram

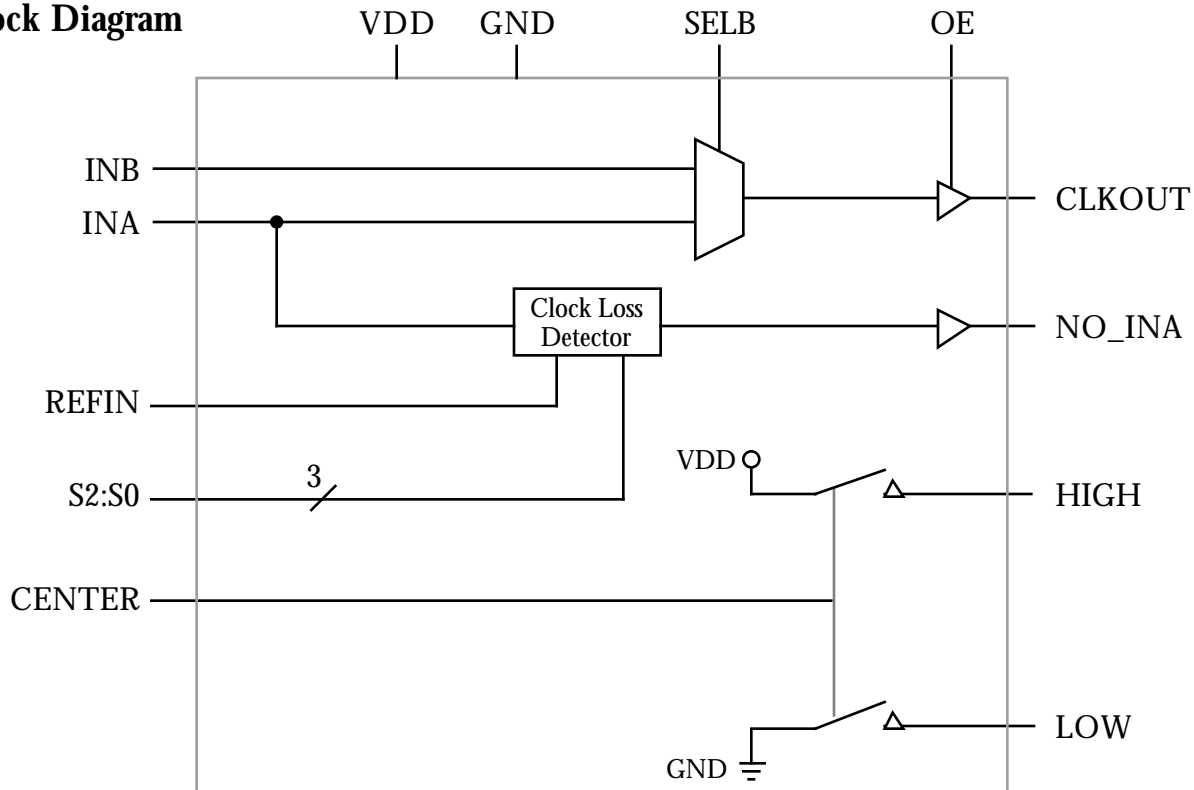



Pin Assignment

S0	<input type="checkbox"/>	1	16	<input type="checkbox"/>	OE
S1	<input type="checkbox"/>	2	15	<input type="checkbox"/>	VDD
S2	<input type="checkbox"/>	3	14	<input type="checkbox"/>	CLKOUT
INB	<input type="checkbox"/>	4	13	<input type="checkbox"/>	NO_INA
INA	<input type="checkbox"/>	5	12	<input type="checkbox"/>	HIGH
GND	<input type="checkbox"/>	6	11	<input type="checkbox"/>	LOW
SELB	<input type="checkbox"/>	7	10	<input type="checkbox"/>	GND
REFIN	<input type="checkbox"/>	8	9	<input type="checkbox"/>	CENTER

16 pin (150 mil) SOIC

Clock Loss Detector Settings

S2	S1	S0	Nominal Count
0	0	0	34
0	0	1	18
0	1	0	130
0	1	1	66
1	0	0	10
1	0	1	6
1	1	0	2
1	1	1	2

Due to the possible phase differences between the REFIN clock and the INA clock, the Nominal Count has a tolerance of -0/+1 REFIN clock edges.

Pin Descriptions

Number	Name	Type	Description
1	S0	I	Clock Count Select 0. Determines allowed number of missing clock edges per table above.
2	S1	I	Clock Count Select 1. Determines allowed number of missing clock edges per table above.
3	S2	I	Clock Count Select 2. Determines allowed number of missing clock edges per table above.
4	INB	I	Input Clock B.
5	INA	I	Input Clock A.
6	GND	P	Connect to ground.
7	SELB	I	Mux select. Selects INB when high.
8	REFIN	I	Reference Clock Input.
9	CENTER	I	Enables HIGH and LOW pins when high.
10	GND	P	Connect to ground.
11	LOW	O	Sets low end of centering range.
12	HIGH	O	Sets high end of centering range.
13	NO_INA	O	Goes high when clock on INA stops.
14	CLKOUT	O	Clock output.
15	VDD	P	Connect to +3.3 V or +5 V.
16	OE	I	Output Enable. Tri-states CLKOUT when low.

Type: I = Input, O = output, P = power supply connection
All inputs have an internal pull-up.



Electrical Specifications

Parameter	Conditions	Minimum	Typical	Maximum	Units
ABSOLUTE MAXIMUM RATINGS (Note 1)					
Supply Voltage, VDD	Referenced to GND			7	V
Inputs and Clock Outputs		-0.5		VDD+0.5	V
Ambient Operating Temperature		-40		85	°C
Soldering Temperature	Max of 10 seconds			250	°C
Storage Temperature		-65		150	°C
DC CHARACTERISTICS (VDD = 3.3 V unless noted)					
Operating Voltage, VDD		3.14		5.25	V
Input High Voltage, VIH (Note 2)	INA, INB	(VDD/2)+1			V
Input Low Voltage, VIL (Note 2)	INA, INB			(VDD/2)-1	V
Input High Voltage, VIH		2			V
Input Low Voltage, VIL				0.8	V
Output High Voltage, VOH, CMOS level	IOH=-4 mA	VDD-0.4			V
Output High Voltage, VOH	IOH=-8 mA	2.4			V
Output Low Voltage	IOL=8 mA			0.4	V
Operating Supply Current, IDD	No Load, VDD=3.3 V		5		mA
Short Circuit Current	Each output		±50		mA
Input Capacitance			7		pF
AC CHARACTERISTICS (VDD = 3.3 V unless noted)					
Input Frequency, External Mode	INA, INB, REFIN	0		100	MHz
Input Clock Pulse Width		4			ns
CLKOUT Settling Time	After SELB change			1	ms
Output Clock Rise Time	0.8 to 2.0 V			1.5	ns
Output Clock Fall Time	2.0 to 0.8 V			1.5	ns
Output Clock Duty Cycle, High Time	At VDD/2	40		60	%

Notes:

1. Stresses beyond those listed under Absolute Maximum Ratings could cause permanent damage to the device. Prolonged exposure to levels above the operating limits but below the Absolute Maximums may affect device reliability.
2. Switching occurs nominally at VDD/2.
- 3: The phase relationship between input and output clocks can change at power up or when switching between INA and INB.

EXTERNAL COMPONENT SELECTION

The MK2042-01 requires a minimum number of external components for proper operation. A decoupling capacitor of 0.01µF must be connected between VDD and GND, pins 15 and 10. This capacitor should be as close to the chip as possible. A series termination resistor of 33 Ω may be used on CLKOUT with traces longer than 1 inch (assuming 50 Ω traces). In applications where the HIGH and LOW outputs are connected to the MK2049-xx, 10 k Ω resistors should be used on each of those outputs.



DETECTING CLOCK LOSS

The MK2042-01 internal Clock Loss Detector compares the REFIN clock to the INA clock to determine when the INA clock is no longer present. During normal operation, the Detector is reset with each rising edge of the INA clock, and the NO_INA output will remain low. In a fault condition where the INA clock is removed, the Detector will use the REFIN clock to wait the pre-determined number of REFIN clock pulses (set by S2:S0 per the table on page 2), and will then force the NO_INA output to a high level.

The NO_INA signal can be used to notify the system that the input clock has been lost, or it can provide automatic switchover to INB. Automatic switchover to INB is achieved by connecting NO_INA to the SELB input, as illustrated in Figure 1. In this case the MK2042-01 will automatically switch CLKOUT to the INB input when the loss of INA is detected. With this configuration, when INA becomes active again, NO_INA will go low and the MK2042-01 will switch CLKOUT to INA. Since the Clock Loss Detector will set NO_INA low as soon as an INA clock edge occurs, sporadic edges on INA could cause CLKOUT to switch unpredictably between INA and INB. Because of this, external system control of SELB is best in cases where the INA clock is sporadic.

Note that proper operation of the Clock Loss Detector requires that there always be a clock on REFIN. The REFIN clock does not need to be the same frequency as the INA clock. Because the REFIN clock and the INA clock are asynchronous, the Clock Loss Detector Count shown in the table on page 2 has a tolerance of -0/+1 REFIN clock edges.

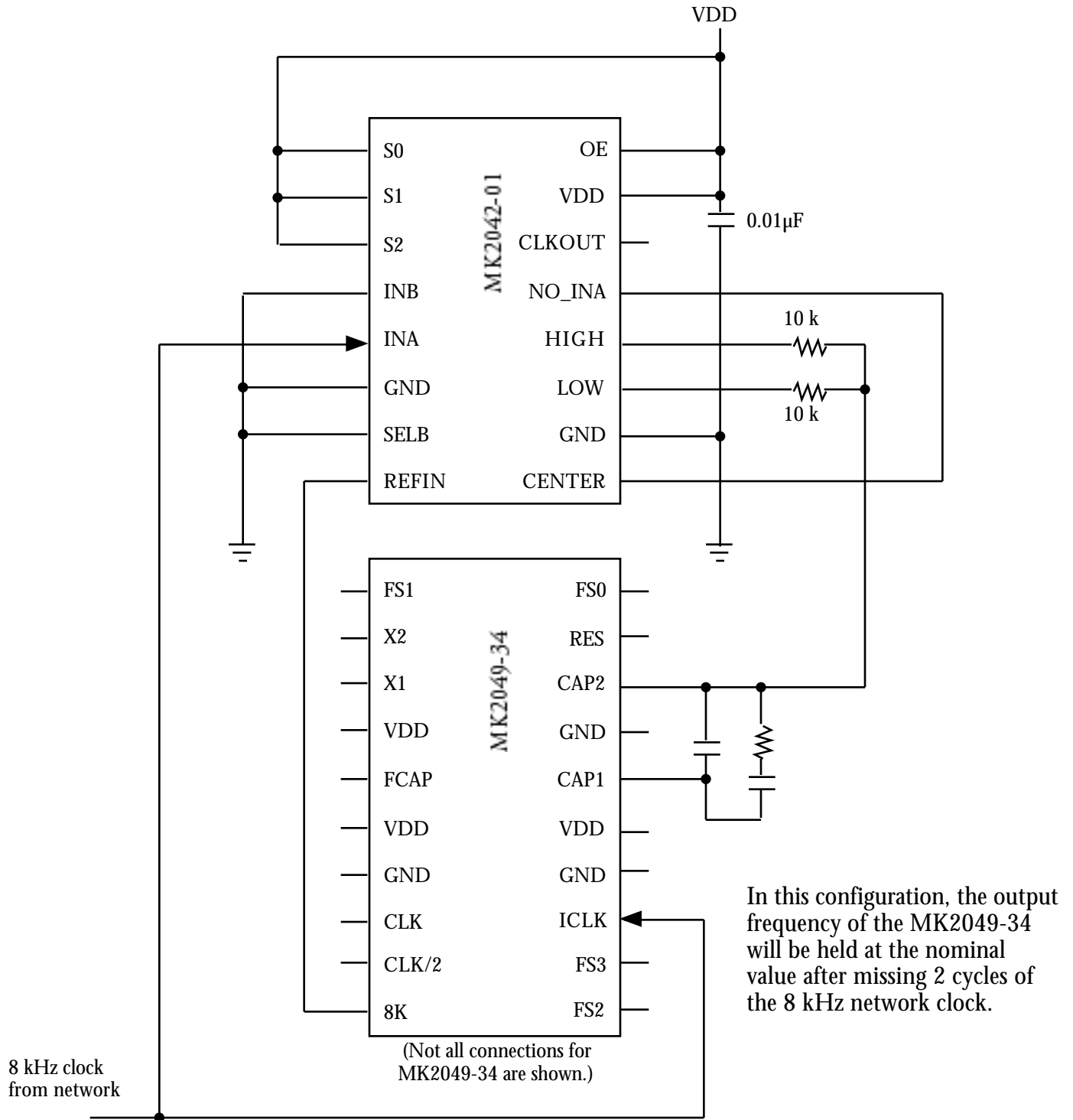

Figure 1. Typical Application of MK2042-01 With MK2049-34



Package Outline and Package Dimensions

(For current dimensional specifications, see JEDEC Publication No. 95.)

16 pin SOIC narrow

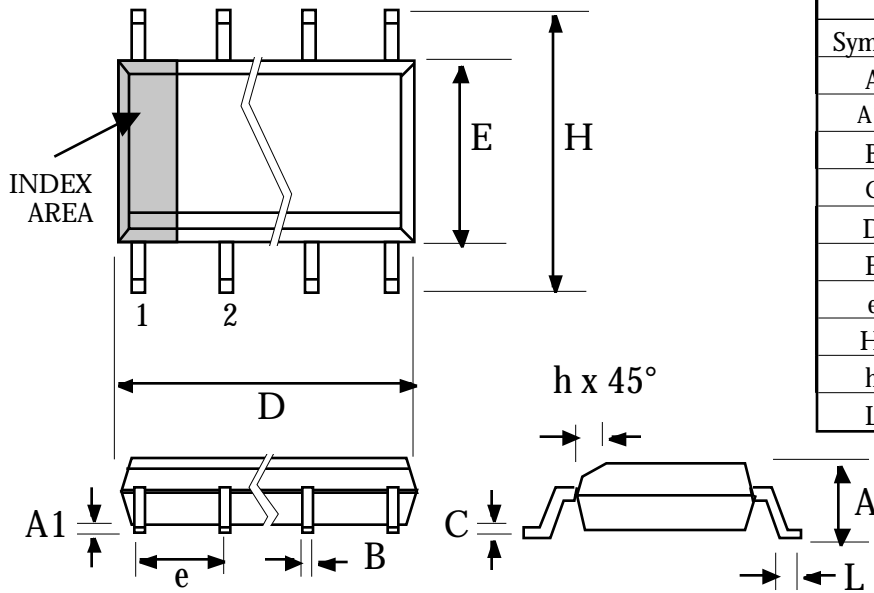

Symbol	Inches		Millimeters	
	Min	Max	Min	Max
A	0.0532	0.0688	1.35	1.75
A1	0.0040	0.0098	0.10	0.24
B	0.0130	0.0200	0.33	0.51
C	0.0075	0.0098	0.19	0.24
D	0.3859	0.3937	9.80	10.00
E	0.1497	0.1574	3.80	4.00
e	.050 BSC		1.27 BSC	
H	0.2284	0.2440	5.80	6.20
h	0.0099	0.0195	0.25	0.50
L	0.0160	0.0500	0.41	1.27

Ordering Information

Part/Order Number	Marking	Package	Temperature
MK2042-01SI	MK2042-01SI	20 pin SOIC	-40 to 85 °C
MK2042-01SITR	MK2042-01SI	Add Tape & Reel	-40 to 85 °C

While the information presented herein has been checked for both accuracy and reliability, Integrated Circuit Systems (ICS) assumes no responsibility for either its use or for the infringement of any patents or other rights of third parties, which would result from its use. No other circuits, patents, or licenses are implied. This product is intended for use in normal commercial applications. Any other applications such as those requiring extended temperature range, high reliability, or other extraordinary environmental requirements are not recommended without additional processing by ICS. ICS reserves the right to change any circuitry or specifications without notice. ICS does not authorize or warrant any ICS product for use in life support devices or critical medical instruments.