

Touch Screen Controller

General Description

The **MK715** Touch Screen Controller IC provides all the screen drive, Analog to Digital converter (ADC) and control circuits to easily interface to 4-wire analog resistive touch screens. It also includes a general purpose A to D converter and a clock synthesizer.

The IC continually monitors the screen waiting for a touch. In this mode, the supply current is typically 4 μ A. When the screen is touched, the IC performs analog to digital conversions to determine the location of the touch, stores the X and Y locations in the registers, and issues an interrupt. This process is repeated up to 303 times per second until no further screen touches are detected, at which time the low current mode is resumed.

The device has a general purpose input into the 10-bit ADC, allowing for the measurement of other inputs such as battery voltage. The MK715 can be powered from a 3.3V supply, and uses an inexpensive 32.768kHz watch crystal as the input reference. An internal Phase-Lock Loop clock synthesizer provides the high speed clock for the ADC, and the option to have a clock output to drive other digital chips in the system.

The tiny package is the same body size as the 14 pin SOIC, with 25 mil spacings on the leads.

Applications

- Notebook Computers
- Handheld Computers
- PDAs
- Touch-screen kiosks

Features

- Tiny 20 pin SSOP (150 mil body)
- 4 microamp standby current
- Less than 3mA active current at 3.3V, including screen drive
- Touch pressure can be measured
- One or two general purpose A to D inputs
- On-chip voltage reference
- 32.768kHz crystal/clock input
- MHz clock outputs available
- Operates with four wire touch screens
- Ratiometric conversion eliminates screen calibration
- Automatic wake up upon screen touch
- Programmable conversion rate to a maximum of 303 points per second
- 3.3V or 5V supply (2.7V version available)
- 10 bit A/D converter
- Full powerdown control
- Touch screen is directly driven - no external transistors are required
- A to D Converter guaranteed monotonic
- 3 or 4 wire serial interface

Pin Assignment

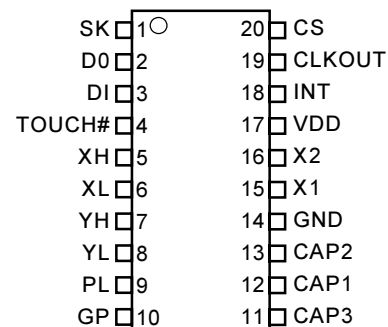

MK715
20 pin SSOP

Pin Descriptions

Pin#	Name	Type	Description
1	SK	I	Serial Clock.
2	DO	O	Data Out. For 3 wire serial port, connect to pin 3.
3	DI	I	Data In. For 3 wire serial port, connect to pin 2.
4	TOUCH#	O	Touch Signal. Goes low when screen is touched. Optional Clock out.
5	XH	TS	Connect to X - high on touch screen (right side).
6	XL	TS	Connect to X - low on touch screen (left side).
7	YH	TS	Connect to Y - high on touch screen (top).
8	YL	TS	Connect to Y - low on touch screen (bottom).
9	PL	I	General purpose ADC input.
10	GP	I	General purpose ADC input.
11	CAP3	-	Connect a 0.01uF capacitor to ground.
12	CAP1	-	Loop filter connection.
13	CAP2	-	Loop filter connection.
14	GND	P	Connect to ground.
15	X1	I	Connect to 32.768 kHz crystal, or ground for clock input.
16	X2	I	Connect to 32.768 kHz crystal or clock input.
17	VDD	P	Connect to +5 V or +3.3 V.
18	INT	O	Interrupt. Goes high to signal interrupt. Optional clock output.
19	CLKOUT	O	Clock output. Typically 32.768 kHz. Can also be MHz output.
20	CS	I	Chip select Active high.

Key: I = Input, O = Output, I/O = Input and Output, P = Power, TS = Touch Screen pin.

Chip Overview

The **MK715** communicates via a 4 pin serial port. This may be connected as either a 3 or 4 wire serial port. The port is connected to 4 registers that control the various modes and function of the chip.

The primary function of the **MK715** is to control resistive touchscreens. There are two ways to read screen points, both controlled by the registers.

In the first method, which is enabled by setting the ENCONR bit, the **MK715** performs periodic conversions at a rate set by the rate register. The chip monitors the touch screen in a low power condition (about 4 μ A) until the screen is touched. When a touch is detected, the chip powers up and starts converting screen points. The TOUCH# pin goes low and INT goes high to indicate a change in touch status. The converter outputs a Y co-ordinate, then an X co-ordinate, then a Y co-ordinate, and so on. The X and Y co-ordinates are stored in the same register (RESULT) and each conversion over-writes the previous conversion. When a co-ordinate is stored, the conversion complete bit is asserted in the STATUS register. This bit is cleared when the RESULT register is read. The inverted state of the TOUCH# pin also appears in the STATUS register. After each co-ordinate conversion, INT goes high and the screen is checked to see if it is still touched. If not, conversions stop, TOUCH# goes high, INT goes high (to indicate a change in touch status) and the chip reverts to the low power mode.

The second method to read a screen is to set the RD1PT (read one point) bit in the CONTROL register. The chip will perform two conversions, a Y co-ordinate followed by an X co-ordinate. The X co-ordinate overwrites the Y co-ordinate and so the X co-ordinate must be read before this happens. Finally, RD1PT is cleared. The conversion pair takes about 3.5 ms.

The converter may also be used to measure voltages presented on the GP or PL pins. The range of the converter is 0 to 1.279 V and so voltages outside this range must be scaled appropriately. Again, the RD1PT bit is set to start the conversion but first either SELGP or SELPL must be set to select the correct input. Only one conversion is performed. The result is stored in the RESULT register and then RD1PT is cleared. The conversion takes about 1.7ms.

The final conversion mode is used to measure touch pressure. This is controlled identically to the second method outlined above except that either RDPRESA or RDPRESB must first be set.

The **MK715** allows for several different clocks to be generated, controlled by the registers. On the CLKOUT pin, the output is either a 32768 Hz clock from the crystal oscillator or a MHz - frequency clock synthesized from the PLL. Similarly, this MHz - frequency clock can appear on the INT or TOUCH# pins instead of their usual functions. In these cases, if the MHz clock needs to run continuously, then the ENPLL bit must be set in order to override the automatic powerdown of the PLL. Refer to page 12 for more details.

Block Diagram

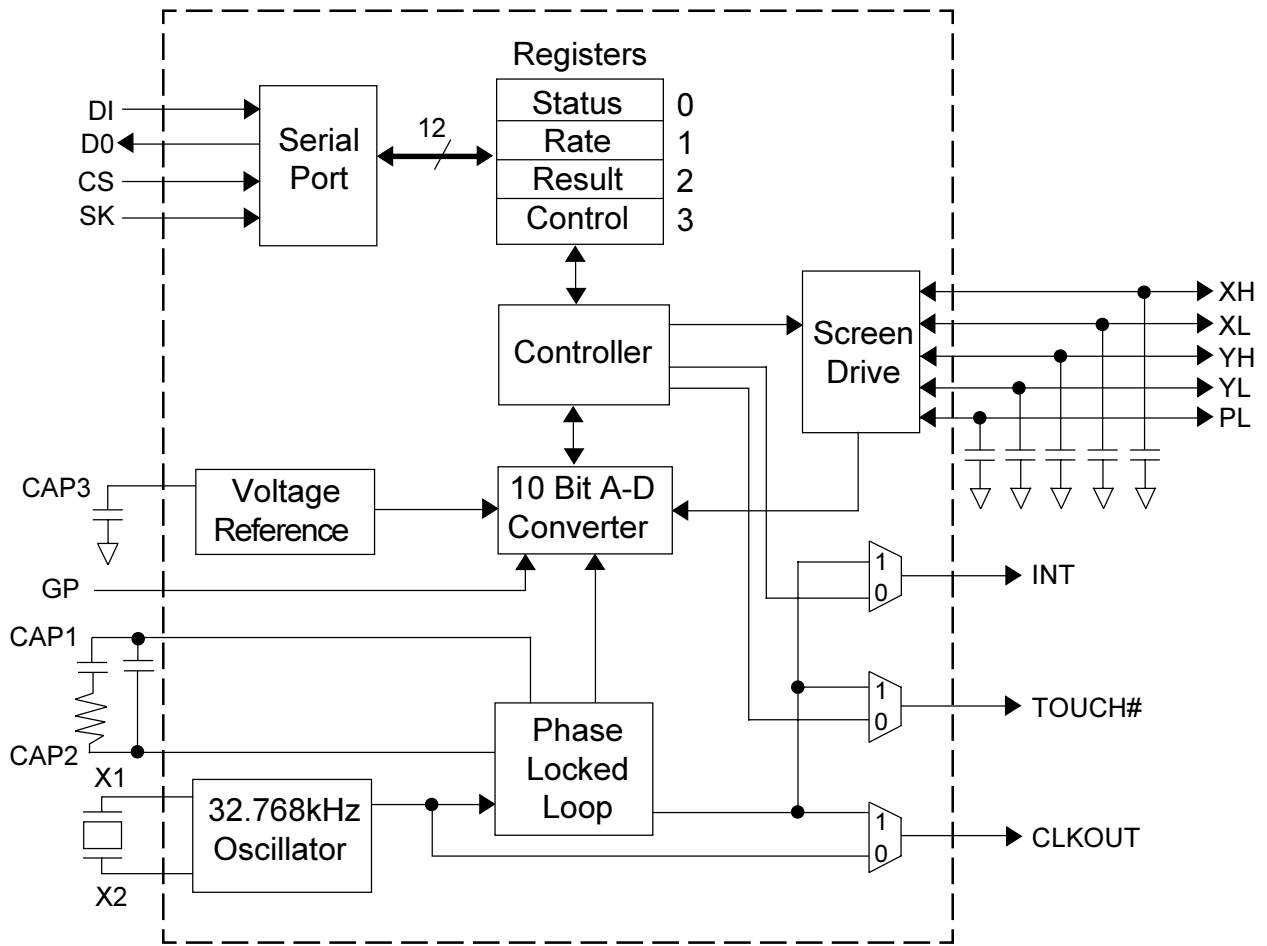

IC Operation

(Periodic Conversions Enabled)

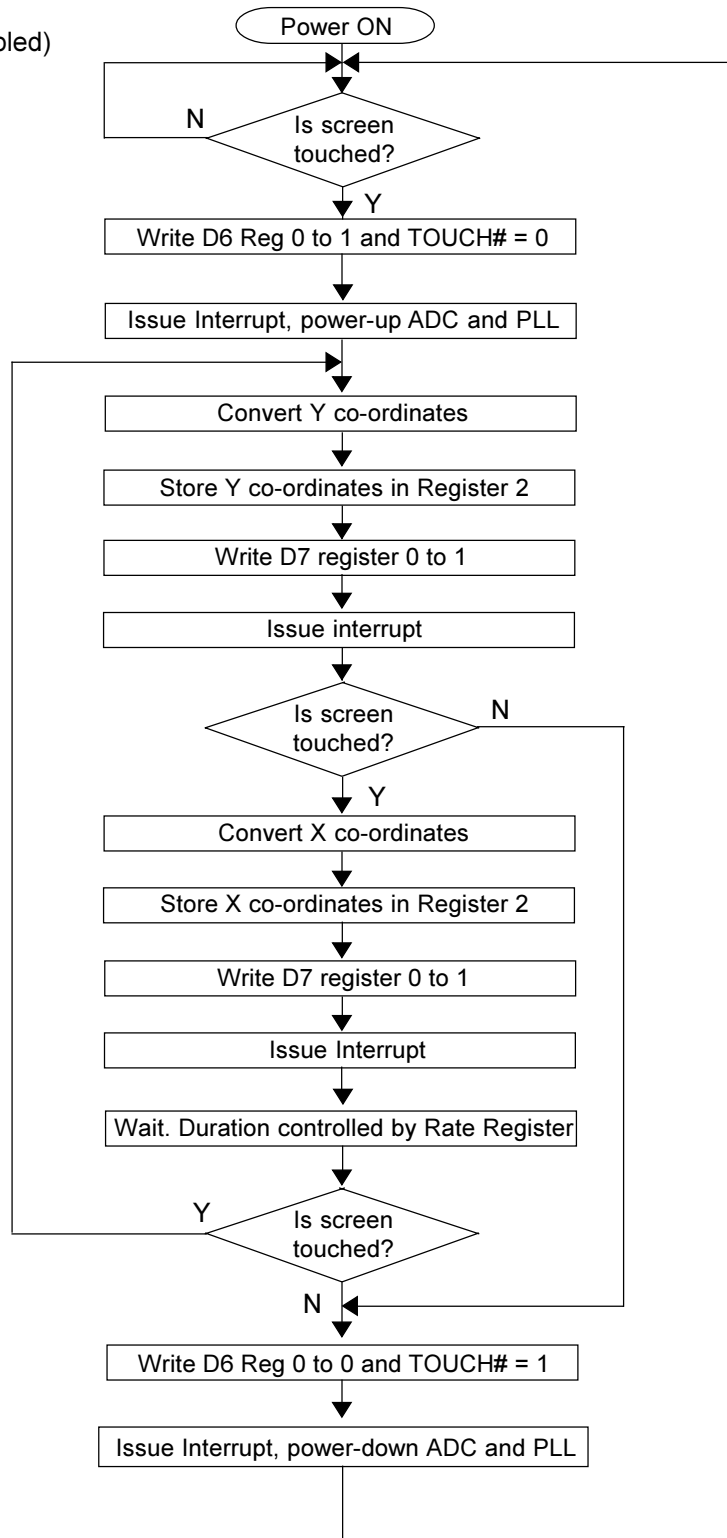

Register Description

The MK715 has four 12 bit registers. However, only 8 bits in each register can be written (D0-D7). The other 4 bits (D8-D11) can never be written and are always read only. The RESULT register contains 2 levels, a read only level and a write only level. Reading this register gives the conversion results. Writing this register changes 4 control bits.

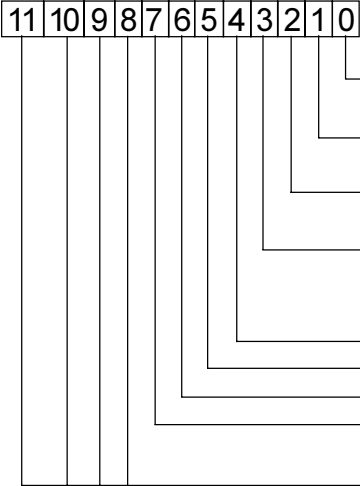
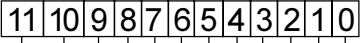
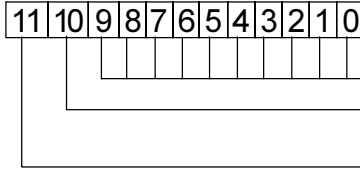
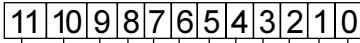
DESCRIPTION	STATUS (ADDRESS 0)	TYPE	Power-up State
Read and Write		RD1PT. Read one point. Cleared when conversion complete.	RW 0
		ENCONR. Enable periodic screen conversions at rate set by RATE register.	RW 0
		PD. Power Down. Chip powers down. See CONTROL register bit 7.	RW 0
		ENPLL. Overrides automatic powerdown of PLL between conversions and forces continuous running.	RW 0
		SELGP. Select GP input to ADC.	RW 0
		SELPL. Select PL input to ADC.	RW 0
		Touch Status. 1 = touch.	RO 0
		Conversion complete. Cleared on next read of RESULT register.	RO 0
		Always set to zero.	RO 0
Read and Write	RATE (ADDRESS 1) 	Controls frequency of screen conversions when periodic conversions are enabled.	RW 32
		Always set to zero.	RO 0
Read	RESULT (ADDRESS 2) 	10-bit conversion result.	RO X
		XSEL. Screen conversion status. 0 = Y coordinate, 1 = X coordinate.	RO 0
		Conversion type. 0 = non-screen conversion, 1 = screen conversion.	RO 1
Write	RESULT (ADDRESS 2) 	RDPRESA. Read pressure A. See description of measuring touch pressure.	WO 0
		RDPRESB. Read pressure B. See description of measuring touch pressure.	WO 0
		PLZERO. Forces PL pin to ground. Can be used to control an external resistor divider.	WO 0
		Test mode. ALWAYS WRITE TO 0.	WO 0
		Don't Care.	- X

Register Description (cont.)

DESCRIPTION	CONTROL (ADDRESS 3)	TYPE	Power-up State												
Read and Write	<table border="1" style="display: inline-table; vertical-align: middle;"> <tr> <td>11</td><td>10</td><td>9</td><td>8</td><td>7</td><td>6</td><td>5</td><td>4</td><td>3</td><td>2</td><td>1</td><td>0</td> </tr> </table>	11	10	9	8	7	6	5	4	3	2	1	0		
11	10	9	8	7	6	5	4	3	2	1	0				
	SEL0. Clock select 0. See page 11.	R/W	0												
	SEL1. Clock select 1. See page 11.	R/W	0												
	SEL2. Clock select 2. See page 11.	R/W	0												
	SEL3. Clock select 3. See page 11.	R/W	0												
	SEL4. Clock select 4. See page 11.	R/W	0												
	CLKSEL. Clock frequency select. See page 11. 0 = 14.3196 MHz 1 = 14.7456 MHz	R/W	0												
	Set to 0.	R/W	0												
	DIS32. Determines state of 32.768 kHz oscillator when PD asserted (STATUS register). Always set to zero.	R/W	0												
		RO	0												

R/W = Read/Write, RO = Read Only, WO = Write Only

Converter Control

RDPRESB	RDPRESA	SELPL	SELGP	ENCONR	RD1PT	CONVERSION PERFORMED
0	0	0	0	0	0 to 1	Performs 2 conversions on the screen - a Y and then an X conversion. RD1PT is then cleared.
0	0	0	0	1	0	Enable conversions at rate as set in RATE register. When screen is touched, converter operates continuously until no touch is detected. Chip then automatically goes to low power, standby state.
0	0	0	1	0	0 to 1	Performs one conversion on GP input. RD1PT is cleared.
0	0	1	0	0	0 to 1	Performs one conversion on PL input. RD1PT is cleared.
0	1	0	0	0	0 to 1	Performs two conversions, a Y and then an X, to give touch pressure data. See section on touch pressure measurement. RD1PT is cleared.
1	0	0	0	0	0 to 1	Performs two conversions, a Y and then an X, to give touch pressure data. See section on touch pressure measurement. RD1PT is cleared.

The converter must be sequenced correctly - before writing RD1PT to one, the appropriate bit (e.g. SELGP) must first be set in a previous write. Only the combinations shown above are permitted. Other combinations will give unpredictable behavior.

Rate Register (Register 2) Programming

Count	P.P.S.	Count	P.P.S.	Count	P.P.S.
0 to 5	Not permitted	25	117	85	40
6	303	26	113	90	38
7	280	27	109	95	36
8	259	28	106	100	34
9	242	29	103	105	32
10	227	30	100	110	31
11	213	31	98	115	30
12	201	32	95	120	29
13	191	33	93	125	28
14	181	34	90	135	26
15	172	35	88	145	24
16	165	40	78	155	22
17	157	45	71	165	21
18	151	50	64	175	20
19	145	55	59	185	19
20	139	60	55	195	18
21	134	65	51	205	17
22	129	70	47	215	16
23	125	75	45	235	15
24	120	80	42	255	14

P.P.S. = Points Per Second. With 14.7456 MHz clock selected.

Calculating Points Per Second

The formula for determining P.P.S. is:

$$\text{P.P.S.} = \frac{\text{fin}}{24072 + (4096 \times \text{COUNT})}$$

Where fin is the frequency of the internal clock (14.3196 MHz or 14.7456 MHz) and COUNT is the value of the rate register.

Power-On Reset

On application of power, an internal reset is generated that clears all bits in registers 0, 2, and 3. Register 1 is set to 32 giving a rate of 92 PPS with 14.3196 MHz selected.

Initializing the MK715

The interrupt on the **MK715** can only be cleared by reading any register or, alternatively, by writing PD (register 0, bit 2) to one, which forces a powerdown. After a fault condition, initialize the **MK715** by writing PD to one, then writing PD to zero. This will always clear pending interrupts.

Warning - Operation under a Power Supply Switching Regulator

When using the **MK715** in a system where the power is supplied by a switching regulator, do not perform screen conversions when the regulator is operating in the power saving mode. Some switching regulators feature a low power mode (for example, Linear Technology's "Burst Mode") where the output is turned on and off in order to save power. The extra power supply noise generated when using this mode causes spurious data points to be returned from the **MK715**, so it should be disabled when the **MK715** is doing screen conversions.

Interrupts

The **MK715** generates an interrupt to signal a change in touch status or to signal that a conversion is complete. The INT pin (pin 2) goes high to signal an interrupt. Interrupts are then cleared by reading any register. However, if the **MK715** is in the process of generating an interrupt during a read cycle, then the interrupt is not cleared and INT will stay high. This internal process may take 100ns, and so to guarantee that the interrupt is cleared, two successive read cycles may be necessary.

Touch Screen Serial Port (Four Wire)

Data is written to, and read from, the MK715 via the serial port. When writing, only 8 data bits can be written to each 12 bit register. The 4 highest order bits (D8-D11) in each register are read only and can never be written. When reading, all 12 bits are returned.

The serial port has 4 pins - serial clock (SK), chip select (CS), data in (DI), and data out (DO). The SK acts on the rising edge. The CS acts as a reset for the serial port with CS going high initiating a cycle. The cycle consists of 2 parts - a write followed by a read. Each part consists of 12 bits. Refer to the serial port diagram on page 10 and timing diagram on page 20.

After CS goes high, any number of leading zeros can occur on DI. When a one is presented (even if this is the first bit after CS goes high), this becomes the start bit. The start bit is followed by 3 op-code bits. The first is a write bit (WR), which determines whether the data following is actually loaded into the appropriate register or not. The next two bits are address bits, which select 1 of 4 on-chip registers. The last 8 bits are data. If WR was low, then these data bits are ignored.

On the fourteenth SK rising edge after a start bit, DO is released from tri-state and data is clocked out of the part. This is the read part of the cycle. The register to be read is selected with the op-code address. The data are 12 bits long. For the result of a conversion (which is stored in register 2), this data consists of 10 bits from the ADC, a bit identifying an X or a Y coordinate, and a bit identifying a screen conversion or a general purpose conversion. For the other 3 registers, the data are only 8 bits long, so the 12 bit output word contains four leading zeros.

After the 12 data bits are clocked out, the DO pin stays active and bits will continue to appear until CS goes low. See the following page for the timing diagram.

Three-Wire Serial Port

To configure the serial port for 3 wires, DI must be connected to DO to form a bi-directional data line. All other timing and configuration remain unchanged.

Using the General Purpose Inputs to the A to D Converter

The GP pin is a general purpose input to the 10 bit ADC. An on-chip 1.297 V reference is used, where 1.297 V is full scale. In addition, when using a 4-wire touch screen, the PL pin is available as a general purpose input, or it can be used as a power control for an external resistor divider:

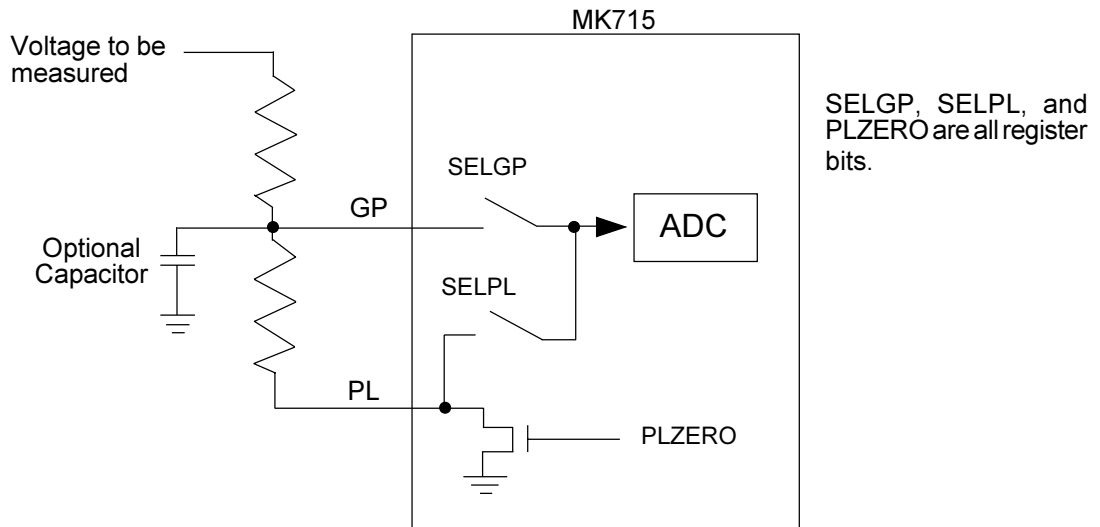

For two voltages, the connection is as follows:

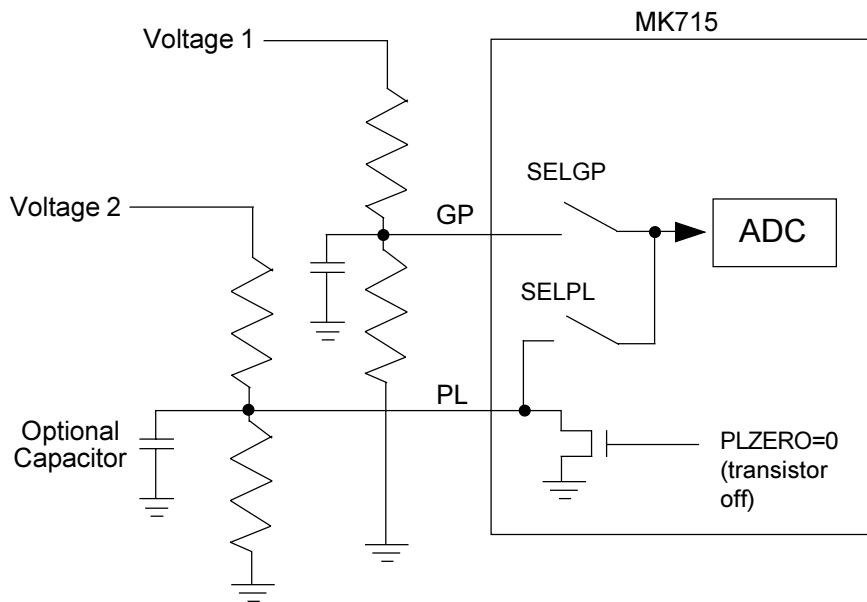

If PL or GP are unused, they should be connected to ground.
The capacitors connected to GP and PL are optional and will reduce noise on the ADC input.

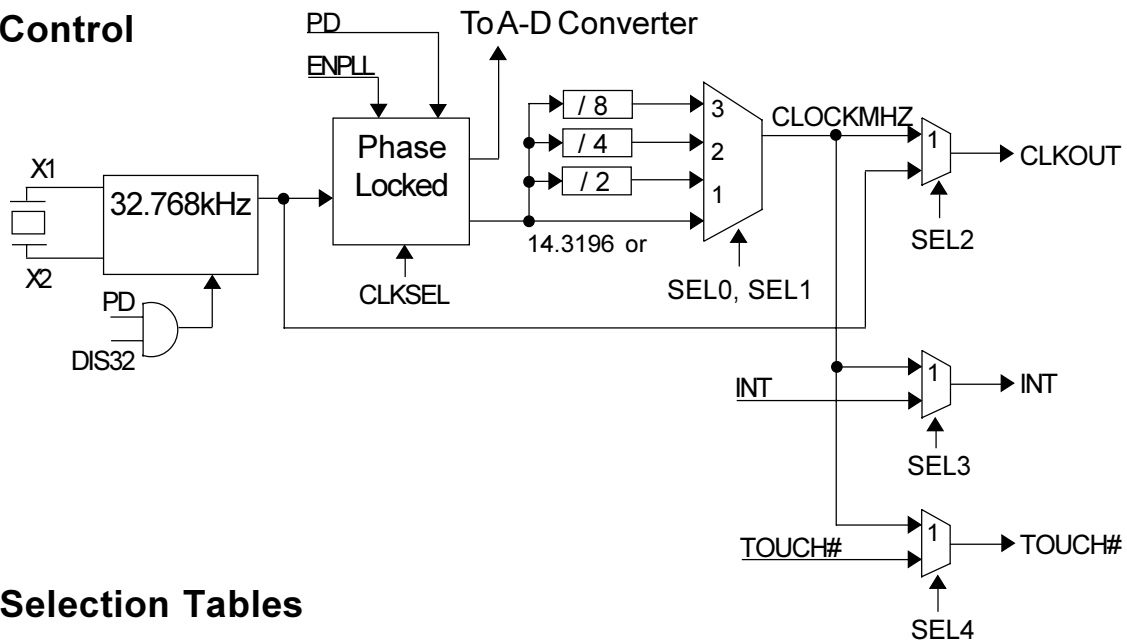
Clock Control

Clock Selection Tables

SEL2	PD	ENPLL	DIS32	CLKOUT FREQ	NOTES
0	0	x	0	32.768	Power-up State
0	0	x	1	32.768	
0	1	x	0	32.768	
0	1	x	1	OFF	
1	0	0	x	MHZ	Runs only when screen touched
1	0	1	x	MHZ	Always Running
1	1	0	x	OFF	
1	1	1	x	OFF	

CKSEL	SEL1	SEL0	CLOCKMHZ
0	0	0	14.3196
0	0	1	7.160
0	1	0	3.580
0	1	1	1.790
1	0	0	14.7456
1	0	1	7.3728
1	1	0	3.6864
1	1	1	1.8432

SEL2	CLOCKOUT
0	32.768 kHz
1	CLOCKMHZ

SEL3	INT
0	INT
1	CLOCKMHZ

SEL4	TOUCH#
0	TOUCH#
1	CLOCKMHZ

Clocks may be programmed to be on any of three pins per the description above. The clocks are controlled by the following register bits (see register description for more details): STATUS register, bits 2 and 3; and CONTROL register bits 0, 1, 2, 3, 4, 5, 7.

Power and Clock Control

The power consumed by the MK715 can be controlled by programming various register bits.

PD	DIS32	ENPLL	ENCONR	Is the Screen Touched?	Chip Condition	Typical IDD
1	0	X	X	X	Everything off	0
1	1	X	X	X	Everything off except crystal oscillator and 32kHz output (if selected)	4 μ A
0	X	0	0	No	Everything off except crystal oscillator and 32 kHz output. TOUCH# and INT pins respond to changes in touch status.	4 μ A
0	X	0	0	Yes	Everything off except crystal oscillator and 32 kHz output. TOUCH# and INT pins respond to changes in touch status.	40 μ A
0	X	1	0	X	Everything off except crystal oscillator, PLL and clock outputs. TOUCH# and INT pins respond to changes in TOUCH status.	2mA (depends on clock frequency and loading)
0	X	0	1	No	Everything off except crystal oscillator and clock outputs.	4 μ A
0	X	1	1	NO	Everything off except crystal oscillator, PLL and clock outputs.	2mA
0	X	X	1	Yes	ADC, PLL, etc. operating.	5mA(See Power Supply Current graphs)

Recommended Circuit

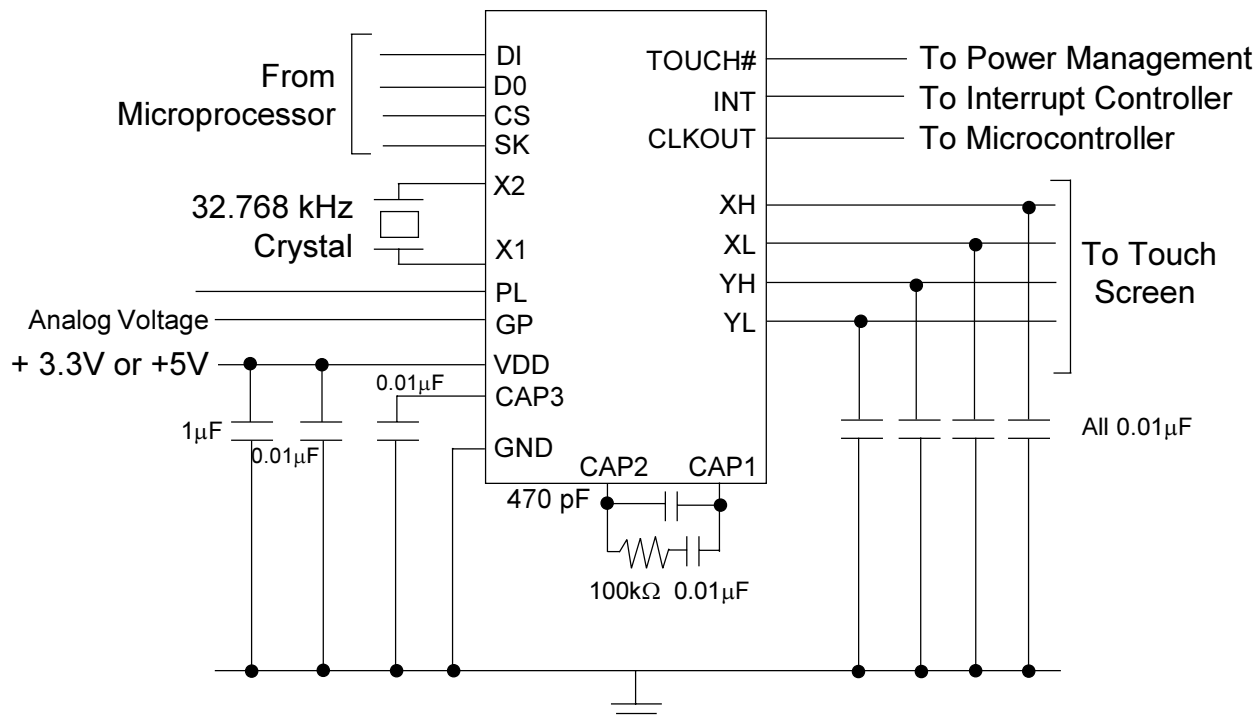

The capacitors connected to CAP1 and CAP3 **must** be low leakage, ceramic type capacitors.

Pen Bounce

When the screen is untouched, the Y plate is driven high and the X plate is driven low. When the screen is touched, the X plate is pulled high, which is detected by the **MK715**. This initiates a conversion, as long as conversions at rate (ENCONR) are enabled. Some de-bounce is provided by the time constant of the screen decoupling capacitors combined with the screen resistance. However, once conversions have started, pen bounce will not be detected until after the current X or Y points have been taken.

If the pen is lifted during a conversion, this will also not be detected until the conversion is complete.

Optimizing Performance when Reading and Writing Registers

Reading and writing the **MK715** generates digital noise that may reduce the accuracy of the A to D converter. This noise has several causes, including board layout, and power supply voltage. By appropriately timing the register operations, the effects of this noise can be minimized.

After an interrupt is issued or RDIP_T is asserted, the **MK715** allows a minimum of 1 millisecond to elapse before initiating the conversion cycle. This allows the screen drivers to settle. For best performance, complete all register operations within this 1ms window after an interrupt.

Resistive Touch Screen (4 Wire)

Resistive touch screens consist of 2 resistive plates that are separated by a small gap. Each plate has an electrode at each end and when the screen is touched, the two plates are shorted together at that point.

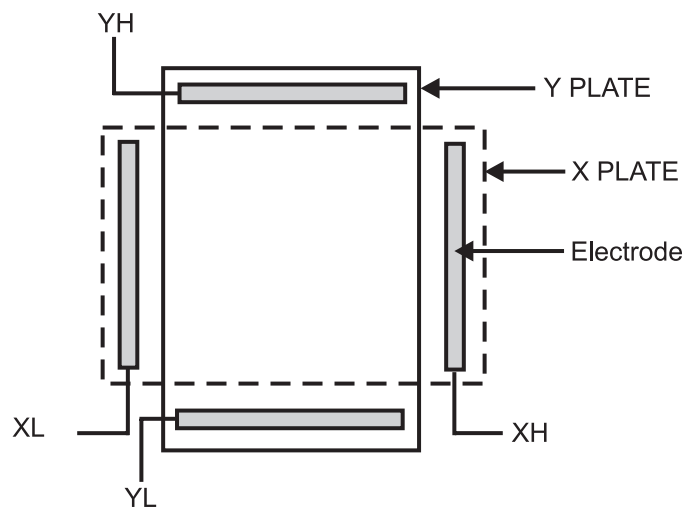

If a voltage is applied, for example, between XL and XH, then a voltage divider is formed on the X PLATE. When the Y PLATE is touched to the X PLATE, a voltage will be developed on the Y PLATE that is proportional to distance of the touch from XL and XH. By accurately measuring this voltage, the position of the touch can be determined.

Analog to Digital Converter Operation with a Touchscreen

The 10-bit ADC converts X and Y co-ordinates at a rate determined by register 1. The converter uses a ratiometric technique to give absolute co-ordinates on the screen, largely independent of variations in screen resistance, temperature or power supply voltage. The total voltage applied across the screen is defined as full-scale for the converter (i.e. 1023) and any point touched on the screen is proportional to this. For example, if the screen is touched exactly in the center, the converter will read 511. This feature may allow for the elimination of calibration upon startup.

However, the full scale voltage is defined at the IC pins and so any parasitic interconnect resistance will be included in full scale. In addition, the interconnect resistances on the screen also account for up to 20% of the total resistance. This means that approximately the bottom 10% and top 10% of full scale are inaccessible.

The converter is guaranteed to be monotonic, with no missing codes.

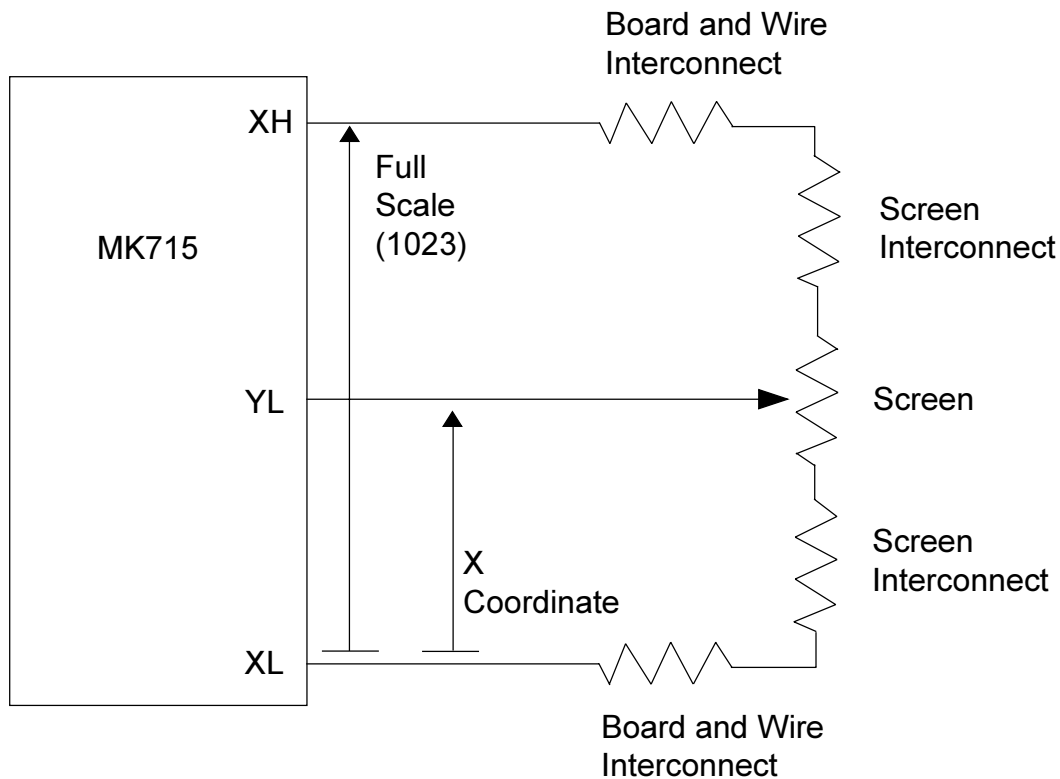

Measuring Touch Pressure

Measuring touch pressure can only be performed on 4-wire touchscreens. In normal operation, the screen drivers force XH high and XL to ground and measure the voltage on the other plate. A schematic of this is as follows:

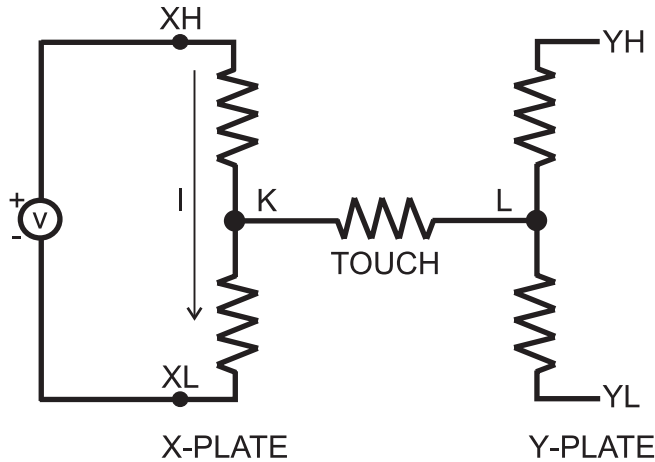

Voltage measured on YH is the same as at K and L giving the X co-ordinate.

When RDPRESA is asserted, the screen drive changes as follows (XSEL=1):

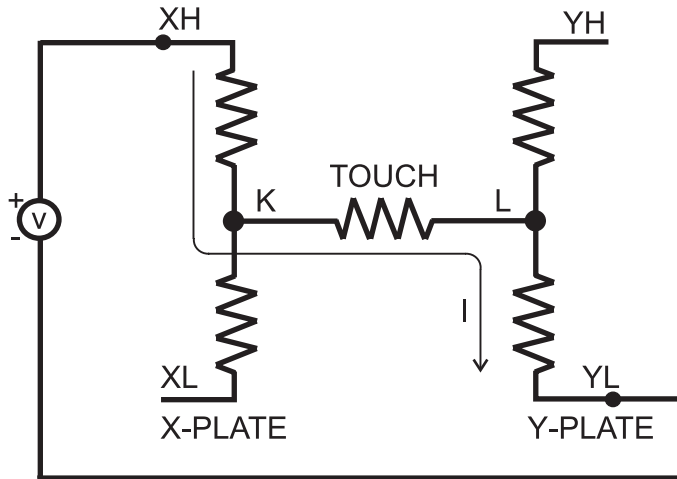

Voltage measured on YH is now the voltage at L. Voltage measured at XL is now the voltage at K. The difference is proportional to the touch pressure.

When RD1PT is asserted, the converter automatically performs two conversions. The status of the XSEL bit identifies the conversions. The following table gives the four measurements available.

RDPRESB	RDPRESA	XSEL	DRIVE	PIN MEASURED
0	1	0	YH, XL	XH
0	1	1	XH, YL	YH
1	0	0	YH, XL	YL
1	0	1	XH, YL	XL

Both points returned in one conversion pair.

Both points returned in one conversion pair.

From these four measurements, the resistance of the touch can be calculated as a proportion of x-plate and y-plate resistance. See the next section for suggestions about calculating the touch resistance. From this, the touch pressure can be inferred. See the table on page 7 for the correct register sequencing of the converter.

Calculating Touch Resistance

There are a total of six measurements possible:

RDPRESB	RDPRESA	XSEL	DRIVE	PIN MEASURED	RESULT
0	0	0	YH, YL	XH	C
0	0	1	XH, XL	YH	D
0	1	0	YH, XL	XH	E
0	1	1	XH, YL	YH	F
1	0	0	YH, XL	YL	G
1	0	1	XH, YL	XL	H

where the result is a number from 0 to 1023.

From simple network theory, R_{TOUCH} can be represented in many ways, 3 are given below:

$$R_{TOUCH} = R_X \cdot \frac{D}{1023} \cdot \left(\frac{G}{E} - 1 \right) \quad \text{where } R_X = X \text{ plate resistance}$$

or
$$R_{TOUCH} = R_Y \cdot \frac{C}{1023} \cdot \left(\frac{H}{F} - 1 \right) \quad \text{where } R_Y = Y \text{ plate resistance}$$

or
$$R_{TOUCH} = \frac{R_X}{E} \cdot \frac{D}{1023} \cdot (1023 - E) - R_Y + \frac{R_Y \cdot C}{1023}$$

Electrical Specifications

Parameter	Conditions	Minimum	Typical	Maximum	Units
ABSOLUTE MAXIMUM RATINGS (Note 1)					
Inputs and Clock Outputs	Referenced to GND	-0.5		VDD+0.5	V
Ambient Operating Temperature		0		70	C
Soldering Temperature	Max of 20 seconds			260	C
Storage Temperature		-65		150	C
DC CHARACTERISTICS (VDD = 3.3 V OR 5 V (unless noted))					
Operating Voltage, VDD		3		5.5	V
Input High Voltage	VDD = 5 V	2			V
Input Low Voltage, VIL	VDD = 5 V			0.8	V
Output High Voltage, VOH	IOH = -2mA	VDD-0.4			V
Output High Voltage, VOH	VDD = 5 V, IOH = 12mA	2.4			V
Output Low Voltage, VOL	VDD = 5 V, IOL = 12mA			.04	V
Input High Voltage, VIH	VDD = 3.3 V	1.9			V
Input Low Voltage, VIL	VDD = 3.3 V			0.4	V
Output High Voltage, VOH	VDD = 3.3 V, IOH = -6mA	2.4			V
Output Low Voltage, VOL	VDD = 3.3 V, IOL = 6mA			0.4	V
Operating Supply Current, IDD, at VDD=5 V	note 2		5		mA
Operating Supply Current, IDD, at VDD=3.3 V	note 2		3		mA
Operating Supply Current IDD standby, clock on	note 3		3		μA
Operating Supply Current, IDD power down	PD=1, no clock		0.2	3	μA
Short Circuit Current	Each output		±50		mA
Input Capacitance			7		pF
Resolution				10	bits
Non-linearity	Monotonic, note 4			±2	LSB
Touch Screen Resistance		100		2000	Ω
Voltage Reference	VDD = 3.3 V, 25 C	1.266	1.279	1.292	V
AC CHARACTERISTICS (VDD = 3.3 V OR 5 V (unless noted))					
Input Clock or Crystal Frequency			32.768		kHz
Output Rise Time	0.8 to 2.0 V, VDD = 5 V			3	ns
Output Fall Time	2.0 to 0.8 V, VDD =5 V			3	ns

Notes:

- Stresses beyond those listed under Absolute Maximum Ratings could cause permanent damage to the device. Prolonged exposure to levels above the operating limits but below the Absolute Maximums may affect device reliability.
- Assumes 300 Ω screen, 100 pps.
- Assumes no touch.
- With no missing codes.



MK715 TIMING DIAGRAM

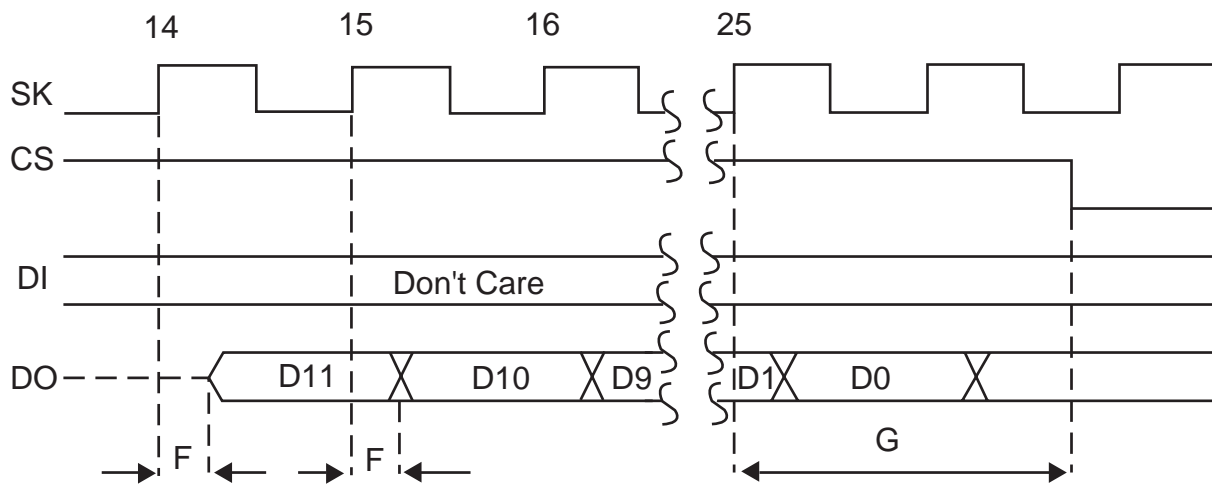
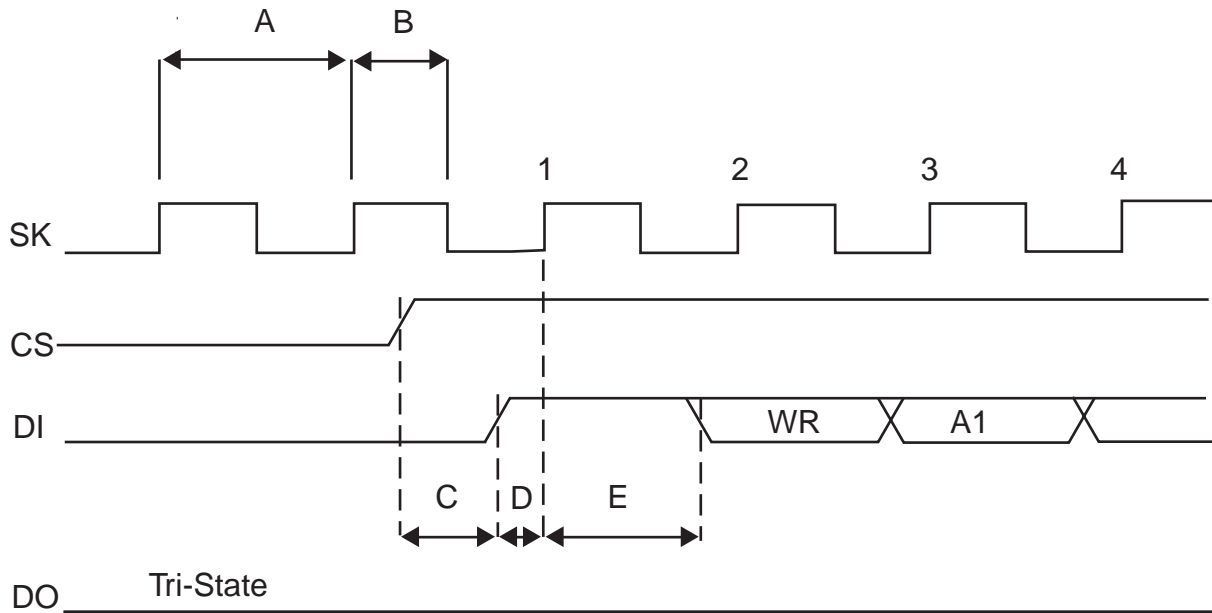

	MIN	MAX	
A SK Period	50		ns
B SK High Time	15	(SK Period) -15	ns
C CS Setup to SK high	15		ns
D DI Setup to SK high	15		ns
E DI Hold from SK high	15		ns
F DO valid from SK high	20		ns
G CS hold from last SK high	50		ns

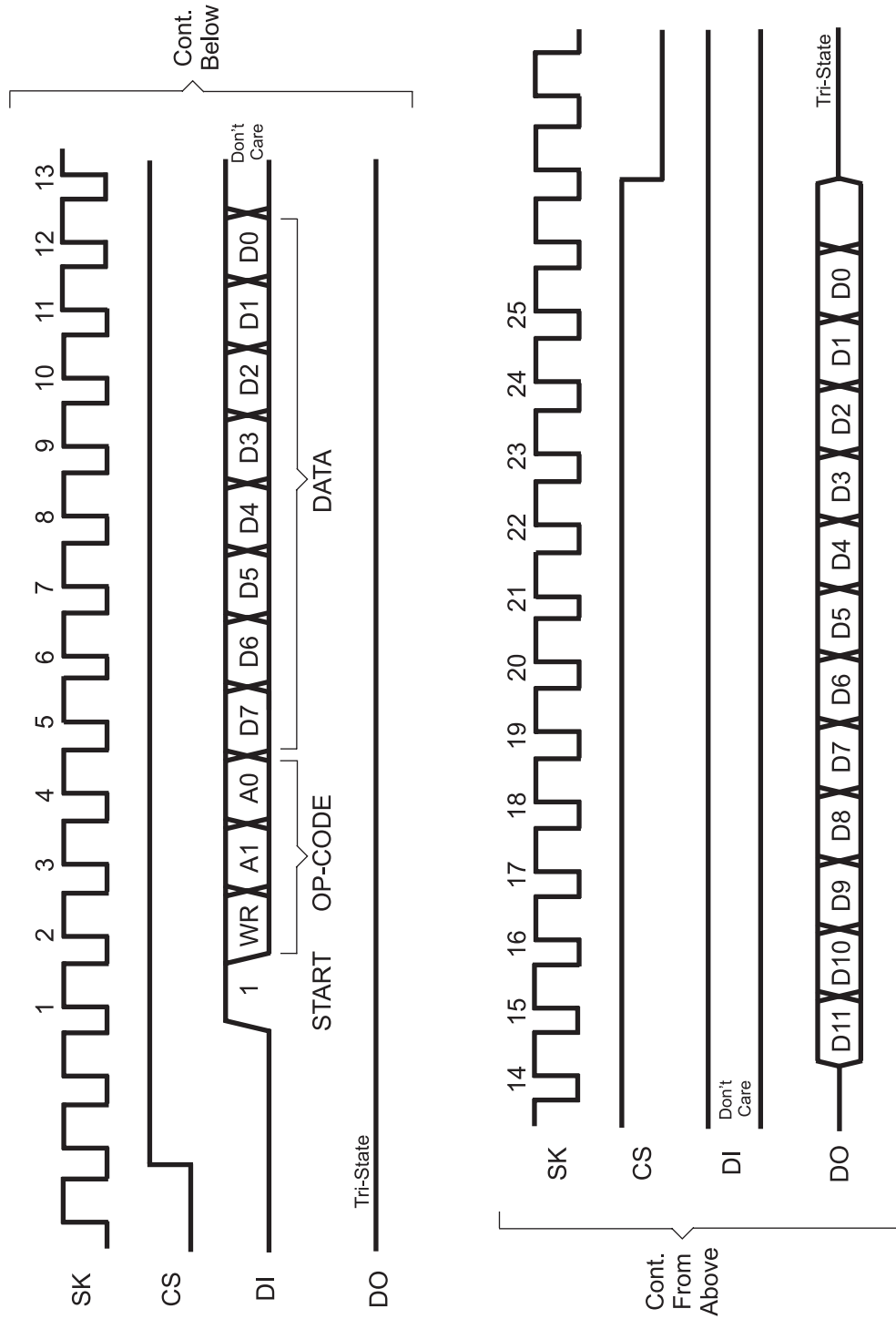

MK715 Serial Port

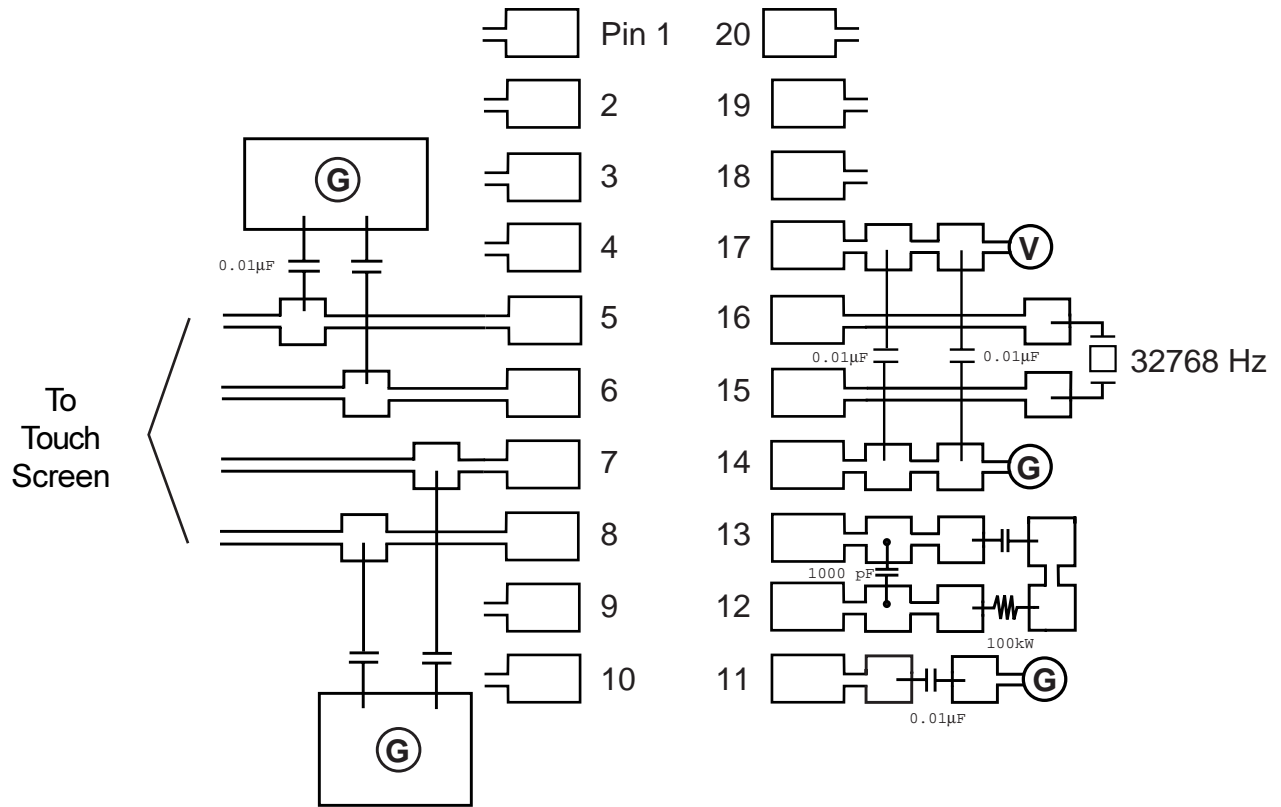

ⓐ = Connection to ground plane

Ⓥ = Connection to VDD plane

Notes: 1. All digital signals should be kept well away from pins 5, 6, 7, 8, 9, 10, 11, 12, 13, 15, 16 and any traces connected to those pins.

Package Outline and Package Dimensions

(For current dimensional specifications, see JEDEC Publication No. 95.)

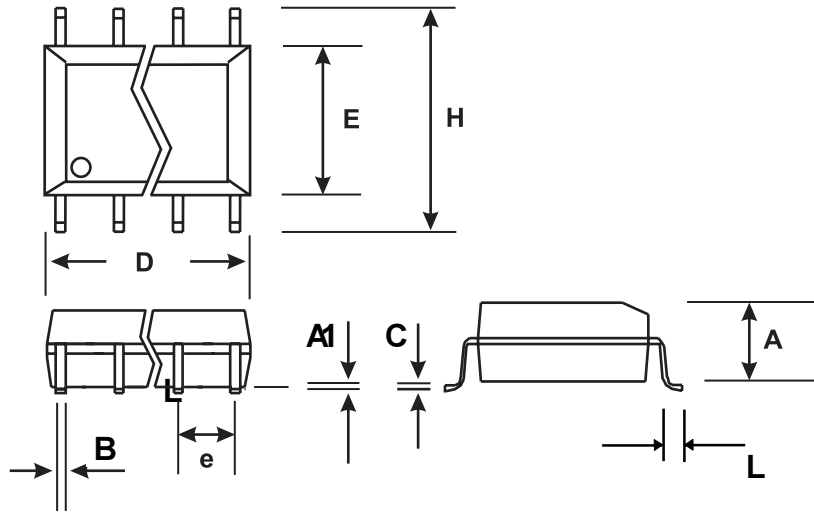

20 pin SSOP (in inches)

Symbol	Min	Max
A	0.053	0.069
A1	0.004	0.010
B	0.008	0.012
C	0.007	0.010
D	0.337	0.344
E	0.150	0.157
e	0.025 BSC	
H	0.228	0.244
L	0.016	0.050

Ordering Information

Part/Order Number	Marking	Shipping
MK715R	MK715R	Tubes
MK715RTR	MK715R	Tape and Reel