



## Description

The ICS674-01 consists of 2 separate configurable dividers. The A Divider is a 7 bit divider and can divide by 3 to 129. The B Divider consists of a 9 bit divider followed by a post divider. The 9 bit divider can divide by 12 to 519. The post divider has eight settings of 1, 2, 4, 5, 6, 7, 8 and 10 giving a maximum total divide of 5190. The A and B Dividers can be cascaded to give a maximum divide of 669510. The ICS674-01 supports the ICS673 PLL Building Block and enables the user to build a full custom PLL synthesizer.

## Features

- Packaged as 28 pin SSOP (150 mil body) 
- Supports ICS673 PLL Building Block
- User determines the divide by setting input pins
- Pull-ups on all select inputs
- Includes one 7-bit Divider for OUTA
- Includes one 9-bit Divider and one selectable Post Divider for OUTB
- Operating voltages of 3.3 V or 5.0 V
- Industrial temperature range available
- 25mA drive capability at TTL levels
- Advanced, low power CMOS process

## Block Diagram

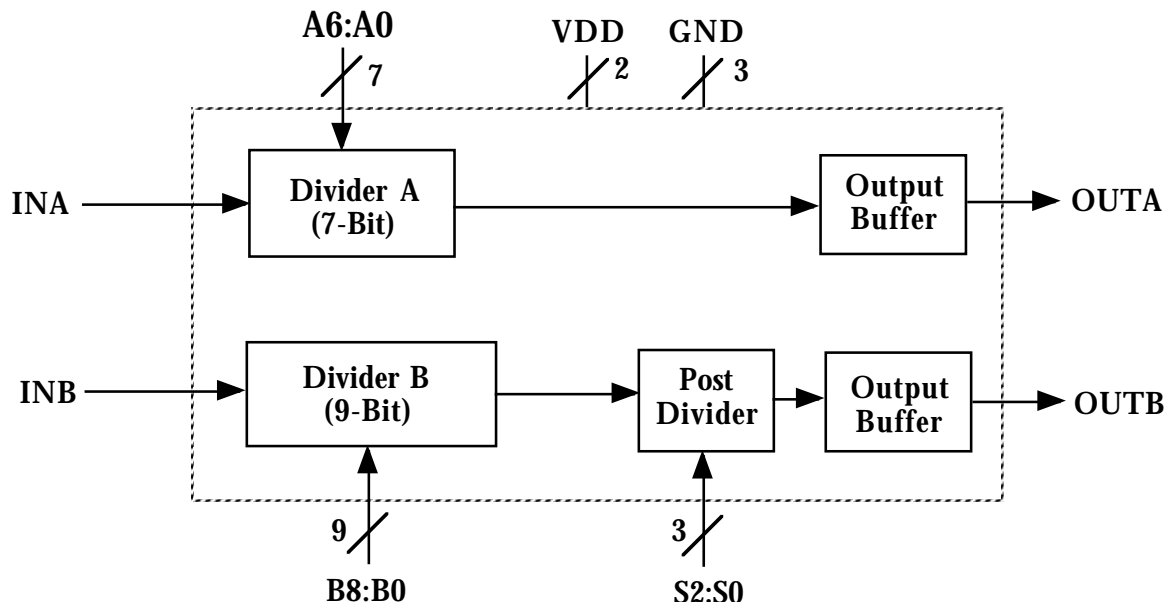

**Pin Assignment**

A5	1	○	28	A4
A6	2		27	A3
S0	3		26	A2
S1	4		25	A1
S2	5		24	A0
VDD	6		23	VDD
INA	7		22	OUTA
INB	8		21	OUTB
GND	9		20	GND
B0	10		19	GND
B1	11		18	B8
B2	12		17	B7
B3	13		16	B6
B4	14		15	B5

**Post Divider Table**

S2 pin 5	S1 pin 4	S0 pin 3	Post Divide
0	0	0	10
0	0	1	2
0	1	0	8
0	1	1	4
1	0	0	5
1	0	1	7
1	1	0	1
1	1	1	6

**Pin Description**

Pin #	Name	Type	Description
1, 2, 24-28	A5, A6, A0-A4	I(PU)	Divider A word input pins. Forms a binary number from 3 to 129.
3, 4, 5	S0, S1, S2	I(PU)	Select pins for Post Divider. See table above.
6, 23	VDD	P	Connect to VDD.
7	INA	I	Divider A input.
8	INB	I	Divider B input.
9, 19, 20	GND	P	Connect to ground.
10-18	B0-B8	I(PU)	Divider B word input pins. Forms a binary number from 12 to 519.
21	OUTB	O	Divider B output.
22	OUTA	O	Divider A output.

Key: I(PU) = Input with internal pull-up resistor; I=Input (no pull-up); O = Output;  
P = Power supply connection

**External Components**

The ICS674-01 requires a 0.01 $\mu$ F decoupling capacitor to be connected between VDD and GND. It must be connected close to the ICS674-01 to minimize lead inductance. Terminating resistors of 33 $\Omega$  can be used in series with the OUTA and OUTB pins.



### Determining (setting) the divider

The user has full control in setting the desired divide. The user should connect the appropriate divider select input pins directly to ground (or VDD, although this is not required because of internal pull-ups) during Printed Circuit Board layout, so that the ICS674-01 automatically produces the correct divide when all components are soldered. It is also possible to connect the inputs to parallel I/O ports in order to change divides.

The divides of the ICS674-01 can be determined by the following simple equations:

$$\text{Divide A} = \text{DAW} + 2$$

Where Divider A Word (DAW) = 1 to 127 (0 is not permitted).

$$\text{Divide B} = (\text{DBW} + 8) \cdot \text{PD}$$

Where Divider B Word (DBW) = 4 to 511 (0,1,2,3, are not permitted).  
Post Divider (PD) = values on Page 2

For example, suppose Divide A is desired to be 61 and Divide B is desired to be 284, then DAW = 59, DBW = 276 and PD = 1. This means A6:A0 is 0111011, B8:B0 is 100010100 and S2:S0 is 110. Since all inputs have pull-ups, it is only necessary to ground the zero pins, namely A6, A2, B7, B6, B5, B3, B1, B0 and S0.



## Using the ICS674-01 with the ICS673-01:

The ICS674-01 may be used with the ICS673-01 to build a frequency synthesizer. The following example shows a typical application when the reference clock is in the MHz range:

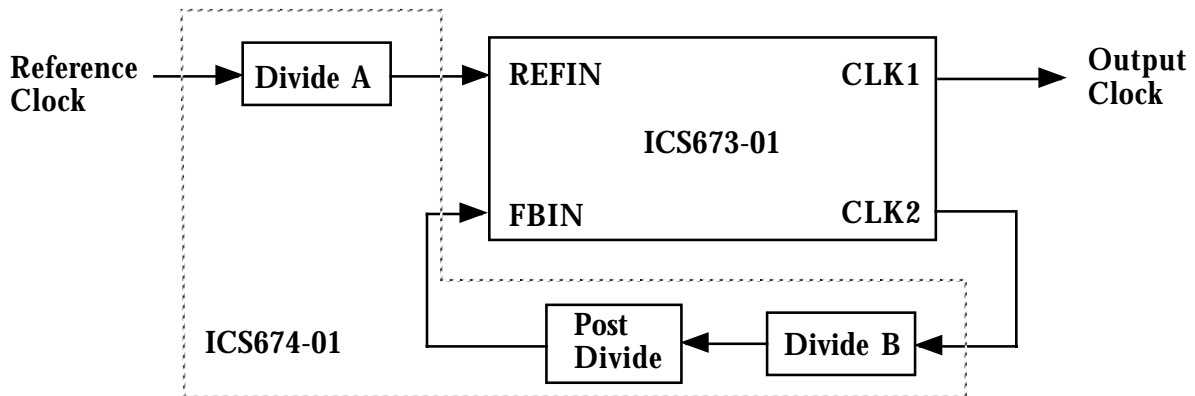

If the reference is in the kHz range, for example 8 kHz, the following configuration may be more typical:

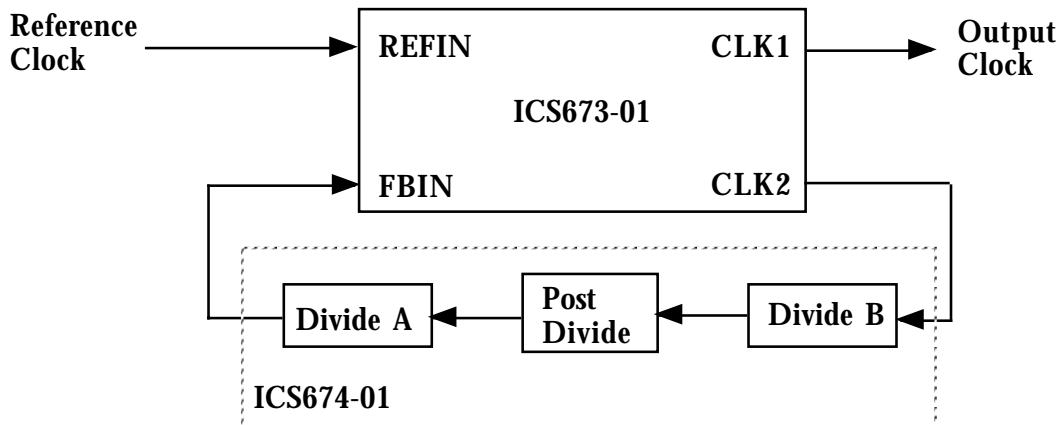

Note that in both examples Divide B is connected to the output of the ICS673. This is because Divide B has a higher operating frequency than Divide A.



Parameter	Conditions	Minimum	Typical	Maximum	Units
<b>ABSOLUTE MAXIMUM RATINGS (stresses beyond these can permanently damage the device)</b>					
Supply Voltage, VDD	Referenced to GND			7	V
Inputs	Referenced to GND	-0.5		VDD+0.5	V
Clock Output	Referenced to GND	-0.5		VDD+0.5	V
Ambient Operating Temperature		0		70	°C
Ambient Operating Temperature	I version	-40		85	°C
Soldering Temperature	Max of 10 seconds			260	°C
Storage Temperature		-65		150	°C
<b>DC CHARACTERISTICS (VDD = 5.0V unless otherwise noted)</b>					
Operating Voltage, VDD		3		5.5	V
Input High Voltage, VIH	All A, B, and S pins	2			V
Input Low Voltage, VIL	All A, B, and S pins			0.8	V
Input High Voltage, VIH, INA and INB only		(VDD/2)+1	VDD/2		V
Input Low Voltage, VIL, INA and INB only			VDD/2	(VDD/2)-1	V
Output High Voltage, VOH	IOH=-25mA	2.4			V
Output Low Voltage, VOL	IOL=25mA			0.4	V
IDD, Op. Supply Cur., DivA=DivB=20 at 3.3 V	No Load, fin=100 MHz		3		mA
IDD, Op. Supply Cur., DivA=DivB=20 at 5 V	No Load, fin=100 MHz		5		mA
Short Circuit Current, outputs			±70		mA
On-Chip Pull-up Resistor	A, B, S select pins		270		kΩ
Input Capacitance	A, B, S select pins		5		pF
<b>AC CHARACTERISTICS (VDD = 5.0V unless otherwise noted)</b>					
Input Frequency, Divider A	at 3.3 V	0		135	MHz
Input Frequency, Divider B	at 3.3 V	0		180	MHz
Input Frequency, Divider A	at 5 V	0		200	MHz
Input Frequency, Divider B	at 5 V	0		235	MHz
Input Frequency, Divider A (Industrial temperature)	at 3.3 V at 85 °C	0		125	MHz
Input Frequency, Divider B (Industrial temperature)	at 3.3 V at 85 °C	0		170	MHz
Input Frequency, Divider A (Industrial temperature)	at 5 V at 85 °C	0		190	MHz
Input Frequency, Divider B (Industrial temperature)	at 5 V at 85 °C	0		220	MHz
Output Clock Rise Time	0.8 to 2.0V		1		ns
Output Clock Fall Time	2.0 to 0.8V		1		ns
OUTB Clock Duty Cycle (see note)	at VDD/2	45	49 to 51	55	%
OUTB Clock Duty Cycle, odd post dividers	at VDD/2, except PD=1	40		60	%
OUTA Clock Duty Cycle (see note)	at VDD/2	20		98.5	%

**Note:**

The duty cycle of OUTA is dependent on the selected divide. This is because OUTA goes low for 2 input clock cycles on INA. So, for example, if a divide of 20 is selected, the duty cycle will be 90%. Similarly, if PD=1 is selected for OUTB, the duty cycle will be dependent on the selected divide. In this case OUTB goes high for approximately 8 input clock cycles on INB.



## Package Outline and Package Dimensions

## 28 pin SSOP

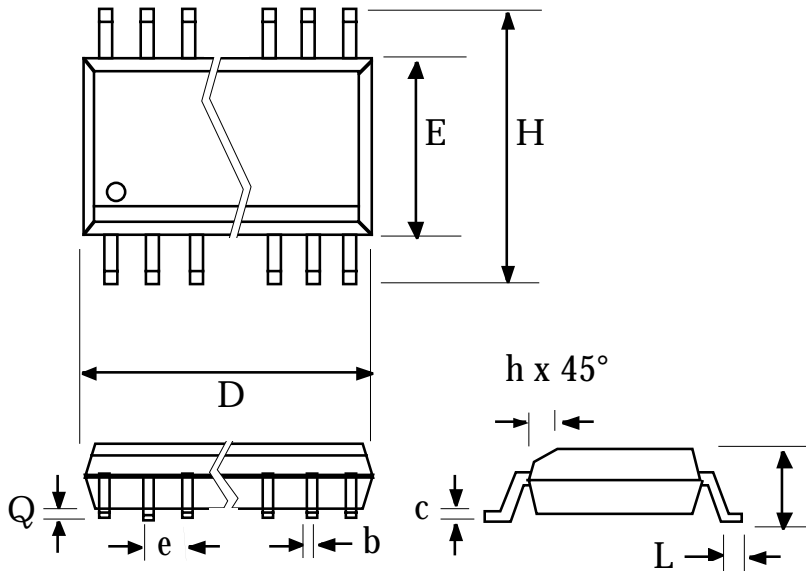

Symbol	Inches		Millimeters	
	Min	Max	Min	Max
A	0.061	0.068	1.55	1.73
b	0.008	0.012	0.203	0.305
c	0.007	0.010	0.191	0.254
D	0.385	0.400	9.779	10.160
E	0.150	0.160	3.810	4.064
H	0.230	0.245	5.842	6.223
e	.025 BSC		0.635 BSC	
h		0.016		0.406
Q	0.004	0.01	0.102	0.254
L	0.016	0.035	0.406	0.889

## Ordering Information

Part/Order Number	Marking *	Package	Temperature
ICS674R-01	674R-01	28 pin narrow SSOP	0 to 70 °C
ICS674R-01T	674R-01	28 pin SSOP on tape and reel	0 to 70 °C
ICS674R-01I	674R-01I	28 pin narrow SSOP	-40 to 85 °C
ICS674R-01IT	674R-01I	28 pin SSOP on tape and reel	-40 to 85 °C

\*This shows the top line marking. The part will have the letters ICS in a box on the upper left hand corner.

While the information presented herein has been checked for both accuracy and reliability, ICS assumes no responsibility for either its use or for the infringement of any patents or other rights of third parties, which would result from its use. No other circuits, patents, or licenses are implied. This product is intended for use in normal commercial applications. Any other applications such as those requiring extended temperature range, high reliability, or other extraordinary environmental requirements are not recommended without additional processing by ICS. ICS reserves the right to change any circuitry or specifications without notice. ICS does not authorize or warrant any ICS product for use in life support devices or critical medical instruments.