

Integrated Device Technology, Inc.

FAST CMOS OCTAL TRANSCEIVER/REGISTER

IDT54/74FCT646
IDT54/74FCT646A
IDT54/74FCT646C

FEATURES:

- IDT54/74FCT646 equivalent to FAST™ speed;
- IDT54/74FCT646A 30% faster than FAST
- IDT54/74FCT646C 40% faster than FAST
- Independent registers for A and B buses
- Multiplexed real-time and stored data
- IOL = 64mA (commercial) and 48mA (military)
- CMOS power levels (1mW typical static)
- TTL input and output level compatible
- CMOS output level compatible
- Available in 24-pin (300 mil) CERDIP, plastic DIP, SOIC, CERPAC and 28-pin LCC
- Product available in Radiation Tolerant and Radiation Enhanced Versions
- Military product compliant to MIL-STD-883, Class B

DESCRIPTION:

The IDT54/74FCT646/A/C consists of a bus transceiver with 3-state D-type flip-flops and control circuitry arranged for multiplexed transmission of data directly from the data bus or from the internal storage registers.

The IDT54/74FCT646/A/C utilizes the enable control (\bar{G}) and direction (DIR) pins to control the transceiver functions.

The SAB and SBA control pins are provided to select either real time or stored data transfer. The circuitry used for select control will eliminate the typical decoding glitch that occurs in a multiplexer during the transition between stored and real-time data. A LOW input level selects real-time data and a HIGH selects stored data.

Data on the A or B data bus or both can be stored in the internal D flip flops by LOW-to-HIGH transitions at the appropriate clock pins (CPAB or CPBA) regardless of the select or enable control pins.

FUNCTIONAL BLOCK DIAGRAM

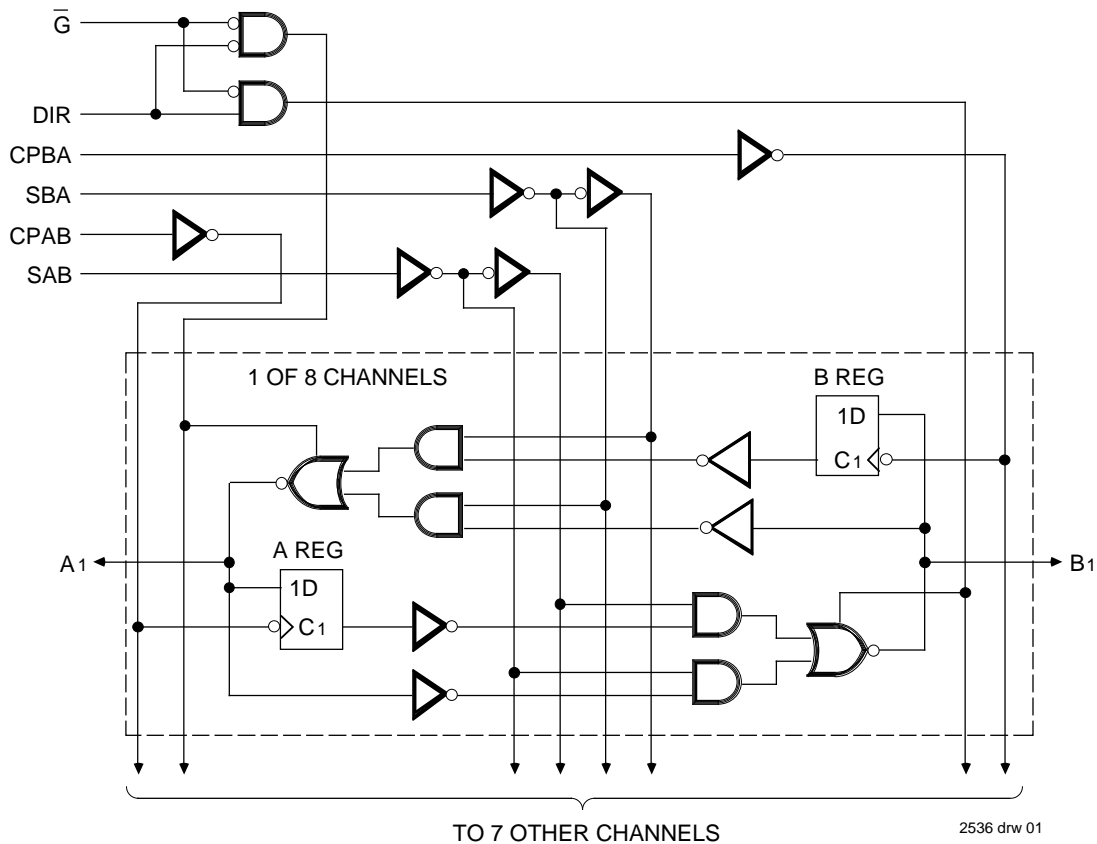

The IDT logo is a registered trademark of Integrated Device Technology, Inc.
FAST is a registered trademark of National Semiconductor Co.

MILITARY AND COMMERCIAL TEMPERATURE RANGES

MAY 1992

PIN CONFIGURATIONS

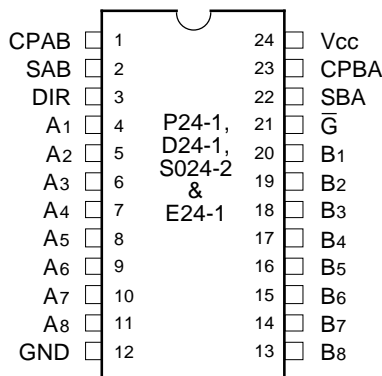

DIP/SOIC/CERPACK
TOP VIEW

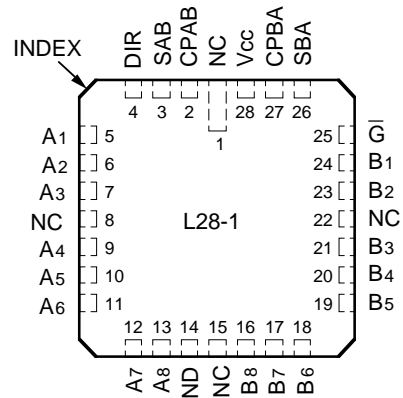

LCC
TOP VIEW

2536 drw 02

PIN DESCRIPTION

Pin Names	Description
A1–A8	Data Register A Inputs Data Register B Outputs
B1–B8	Data Register B Inputs Data Register A Outputs
CPAB, CPBA	Clock Pulse Inputs
SAB, SBA	Output Data Source Select Inputs
DIR, \bar{G}	Output Enable Inputs

2536 tbl 01

LOGIC SYMBOL

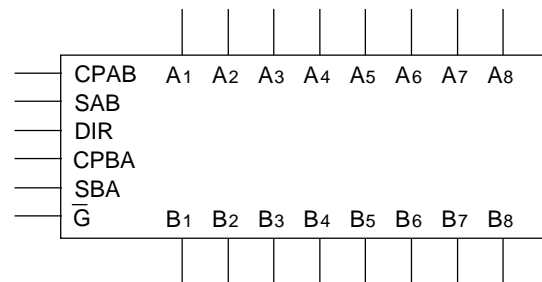

2536 drw 06

FUNCTION TABLE⁽²⁾

Inputs						Data I/O ⁽¹⁾		Operation or Function
\bar{G}	DIR	CPAB	CPBA	SAB	SBA	A1–A8	B1–B8	IDT54/74FCT646
H	X	H or L	H or L	X	X	Input	Input	Isolation Store A and B Data
H	X	↑	↑	X	X			
L	L	X	X	X	L	Output	Input	Real-Time B Data to A Bus Stored B Data to A Bus
L	L	X	H or L	X	H			
L	H	X	X	L	X	Input	Output	Real-Time A Data to B Bus Stored A Data to B Bus
L	H	H or L	X	H	X			

NOTES:

- The data output functions may be enabled or disabled by various signals at the \bar{G} or DIR inputs. Data input functions are always enabled, i.e., data at the bus pins will be stored on every LOW-to-HIGH transition on the clock inputs.
- H = HIGH, L = LOW, X = Don't Care, ↑ = LOW-to-HIGH Transition.

2536 tbl 02

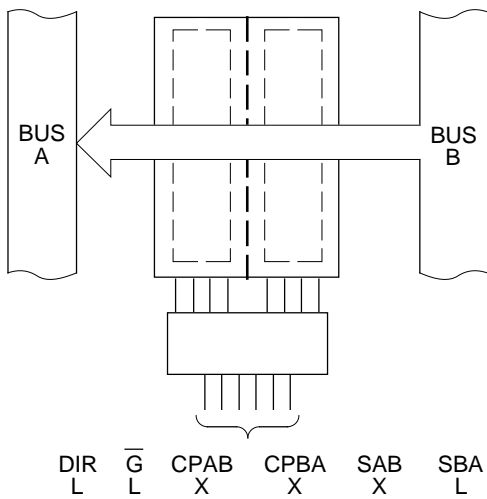

**REAL-TIME TRANSFER
BUS B TO BUS A**

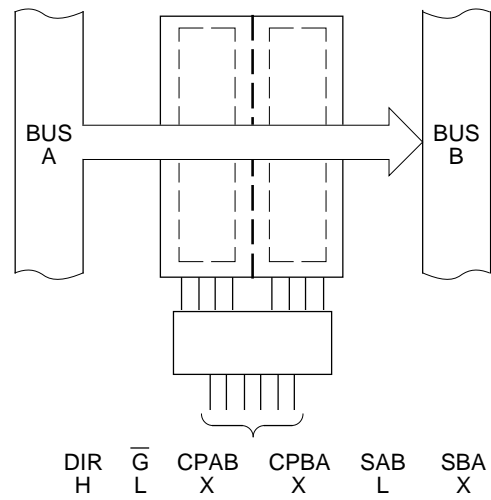

**REAL-TIME TRANSFER
BUS A TO BUS B**

2536 drw 03

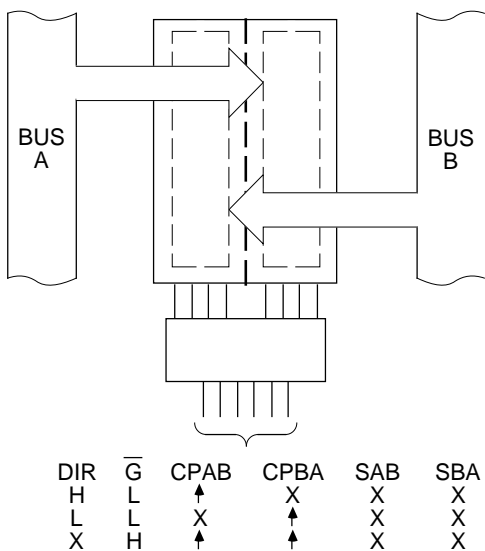

**STORAGE FROM
A AND/OR B**

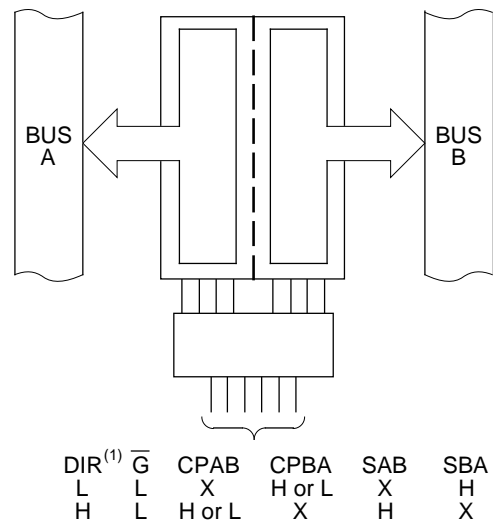

**TRANSFER STORED
DATA TO A AND/OR B**

2536 drw 04

NOTE:

1. Cannot transfer data to A bus and B bus simultaneously.

ABSOLUTE MAXIMUM RATINGS⁽¹⁾

Symbol	Rating	Commercial	Military	Unit
V _{TERM} ⁽²⁾	Terminal Voltage with Respect to GND	-0.5 to +7.0	-0.5 to +7.0	V
V _{TERM} ⁽³⁾	Terminal Voltage with Respect to GND	-0.5 to V _{CC}	-0.5 to V _{CC}	V
T _A	Operating Temperature	0 to +70	-55 to +125	°C
T _{BIAS}	Temperature Under Bias	-55 to +125	-65 to +135	°C
T _{STG}	Storage Temperature	-55 to +125	-65 to +150	°C
P _T	Power Dissipation	0.5	0.5	W
I _{OUT}	DC Output Current	120	120	mA

NOTES:

2536 tbl 03

1. Stresses greater than those listed under ABSOLUTE MAXIMUM RATINGS may cause permanent damage to the device. This is a stress rating only and functional operation of the device at these or any other conditions above those indicated in the operational sections of this specification is not implied. Exposure to absolute maximum rating conditions for extended periods may affect reliability. No terminal voltage may exceed V_{CC} by +0.5V unless otherwise noted.
2. Inputs and V_{CC} terminals only.
3. Outputs and I/O terminals only.

CAPACITANCE (T_A = +25°C, f = 1.0MHz)

Symbol	Parameter ⁽¹⁾	Conditions	Typ.	Max.	Unit
C _{IN}	Input Capacitance	V _{IN} = 0V	6	10	pF
C _{I/O}	I/O Capacitance	V _{OUT} = 0V	8	12	pF

NOTE:

2536 tbl 04

1. This parameter is measured at characterization but not tested.

DC ELECTRICAL CHARACTERISTICS OVER OPERATING RANGE

Following Conditions Apply Unless Otherwise Specified: V_{LC} = 0.2V; V_{HC} = V_{CC} - 0.2V

Commercial: T_A = 0°C to +70°C, V_{CC} = 5.0V ± 5%; Military: T_A = -55°C to +125°C, V_{CC} = 5.0V ± 10%

Symbol	Parameter	Test Conditions ⁽¹⁾	Min.	Typ. ⁽²⁾	Max.	Unit		
V _{IH}	Input HIGH Level	Guaranteed Logic HIGH Level	2.0	—	—	V		
V _{IL}	Input LOW Level	Guaranteed Logic LOW Level	—	—	0.8	V		
I _{IH}	Input HIGH Current (Except I/O pins)	V _{CC} = Max. V _I = V _{CC} V _I = 2.7V	—	—	5	μA		
I _{IL}	Input LOW Current (Except I/O pins)		V _I = 0.5V V _I = GND	—	—		5 ⁽⁴⁾ -5 ⁽⁴⁾	
I _{IH}	Input HIGH Current (I/O pins only)	V _{CC} = Max. V _I = V _{CC} V _I = 2.7V	—	—	15	μA		
I _{IL}	Input LOW Current (I/O pins only)		V _I = 0.5V V _I = GND	—	—		15 ⁽⁴⁾ -15 ⁽⁴⁾	
V _{IK}	Clamp Diode Voltage	V _{CC} = Min., I _N = -18mA	—	-0.7	-1.2	V		
I _{OS}	Short Circuit Current	V _{CC} = Max. ⁽³⁾ , V _O = GND	-60	-120	—	mA		
V _{OH}	Output HIGH Voltage	V _{CC} = 3V, V _{IN} = V _{LC} or V _{HC} , I _{OH} = -32μA	V _{HC}	V _{CC}	—	V		
V _{OL}		Output LOW Voltage	V _{CC} = Min. V _{IN} = V _{IH} or V _{IL}	I _{OH} = -300μA I _{OH} = -12mA MIL. I _{OH} = -15mA COM'L.	V _{HC} 2.4 2.4		V _{CC} 4.0 4.0	— — —
			V _{CC} = 3V, V _{IN} = V _{LC} or V _{HC} , I _{OL} = 300μA	—	GND		V _{LC}	V
V _{OL}	Output LOW Voltage	V _{CC} = Min. V _{IN} = V _{IH} or V _{IL}	I _{OL} = 300μA I _{OL} = 48mA MIL. I _{OL} = 64mA COM'L.	— — —	GND 0.3 0.3	V _{LC} ⁽⁴⁾ 0.55 0.55		

NOTES:

2536 tbl 05

1. For conditions shown as Max. or Min., use appropriate value specified under Electrical Characteristics for the applicable device type.
2. Typical values are at V_{CC} = 5.0V, +25°C ambient and maximum loading.
3. Not more than one output should be shorted at one time. Duration of the short circuit test should not exceed one second.
4. This parameter is guaranteed but not tested.

POWER SUPPLY CHARACTERISTICS

$V_{LC} = 0.2V$; $V_{HC} = V_{CC} - 0.2V$

Symbol	Parameter	Test Conditions ⁽¹⁾		Min.	Typ. ⁽²⁾	Max.	Unit
I _{CC}	Quiescent Power Supply Current	V _{CC} = Max. V _{IN} ≥ V _{HC} ; V _{IN} ≤ V _{LC}		—	0.2	1.5	mA
ΔI _{CC}	Quiescent Power Supply Current TTL Inputs HIGH	V _{CC} = Max. V _{IN} = 3.4V ⁽³⁾		—	0.5	2.0	mA
I _{CCD}	Dynamic Power Supply Current ⁽⁴⁾	V _{CC} = Max. Outputs Open \bar{G} = DIR = GND One Input Toggling 50% Duty Cycle	V _{IN} ≥ V _{HC} V _{IN} ≤ V _{LC}	—	0.15	0.25	mA/MHz
I _C	Total Power Supply Current ⁽⁶⁾	V _{CC} = Max. Outputs Open f _{CP} = 10MHz 50% Duty Cycle \bar{G} = DIR = GND One Bit Toggling at f _i = 5MHz 50% Duty Cycle	V _{IN} ≥ V _{HC} V _{IN} ≤ V _{LC} (FCT)	—	1.7	4.0	mA
			V _{IN} = 3.4V V _{IN} = GND	—	2.2	6.0	
		V _{CC} = Max. Outputs Open f _{CP} = 10MHz 50% Duty Cycle \bar{G} = DIR = GND Eight Bits Toggling at f _i = 5MHz 50% Duty Cycle	V _{IN} ≥ V _{HC} V _{IN} ≤ V _{LC} (FCT)	—	7.0	12.8 ⁽⁵⁾	
			V _{IN} = 3.4V V _{IN} = GND	—	9.2	21.8 ⁽⁵⁾	

NOTES:

2536 tbl 06

1. For conditions shown as Max. or Min., use appropriate value specified under Electrical Characteristics for the applicable device type.

2. Typical values are at V_{CC} = 5.0V, +25°C ambient.

3. Per TTL driven input (V_{IN} = 3.4V); all other inputs at V_{CC} or GND.

4. This parameter is not directly testable, but is derived for use in Total Power Supply calculations.

5. Values for these conditions are examples of the I_{CC} formula. These limits are guaranteed but not tested.

6. I_C = I_{QUIESCENT} + I_{INPUTS} + I_{DYNAMIC}

I_C = I_{CC} + ΔI_{CC} D_HN_T + I_{CCD} (f_{CP}/2 + f_iN_i)

I_{CC} = Quiescent Current

ΔI_{CC} = Power Supply Current for a TTL High Input (V_{IN} = 3.4V)

D_H = Duty Cycle for TTL Inputs High

N_T = Number of TTL Inputs at D_H

I_{CCD} = Dynamic Current Caused by an Output Transition Pair (HLH or LHL)

f_{CP} = Clock Frequency for Register Devices (Zero for Non-Register Devices)

f_i = Input Frequency

N_i = Number of Inputs at f_i

All currents are in milliamps and all frequencies are in megahertz.

SWITCHING CHARACTERISTICS OVER OPERATING RANGE

Symbol	Parameter	Condition ⁽¹⁾	54/74FCT646				54/74FCT646A				54/74FCT646C				Unit
			Com'l.		Mil.		Com'l.		Mil.		Com'l.		Mil.		
			Min. ⁽²⁾	Max.	Min. ⁽²⁾	Max.	Min. ⁽²⁾	Max.	Min. ⁽²⁾	Max.	Min. ⁽²⁾	Max.	Min. ⁽²⁾	Max.	
tPLH tPHL	Propagation Delay Bus to Bus	CL = 50 pF RL = 500Ω	2.0	9.0	2.0	11.0	2.0	6.3	2.0	7.7	1.5	5.4	1.5	6.0	ns
tPZH tPZL	Output Enable Time \bar{G} , DIR to Bus		2.0	14.0	2.0	15.0	2.0	9.8	2.0	10.5	1.5	7.8	1.5	8.9	ns
tPHZ tPLZ	Output Disable Time \bar{G} , DIR to Bus		2.0	9.0	2.0	11.0	2.0	6.3	2.0	7.7	1.5	6.3	1.5	7.7	ns
tPLH tPHL	Propagation Delay Clock to Bus		2.0	9.0	2.0	10.0	2.0	6.3	2.0	7.0	1.5	5.7	1.5	6.3	ns
tPLH tPHL	Propagation Delay SBA or SAB to Bus		2.0	11.0	2.0	12.0	2.0	7.7	2.0	8.4	1.5	6.2	1.5	7.0	ns
tsu	Set-up Time HIGH or LOW Bus to Clock		4.0	—	4.5	—	2.0	—	2.0	—	2.0	—	2.0	—	ns
tH	Hold Time HIGH or LOW Bus to Clock		2.0	—	2.0	—	1.5	—	1.5	—	1.5	—	1.5	—	ns
tw	Clock Pulse Width HIGH or LOW		6.0	—	6.0	—	5.0	—	5.0	—	5.0	—	5.0	—	ns

NOTES:

1. See test circuit and waveforms.
2. Minimum limits are guaranteed but not tested on Propagation Delays.

2536 tbl 07

TEST CIRCUITS AND WAVEFORMS

TEST CIRCUITS FOR ALL OUTPUTS

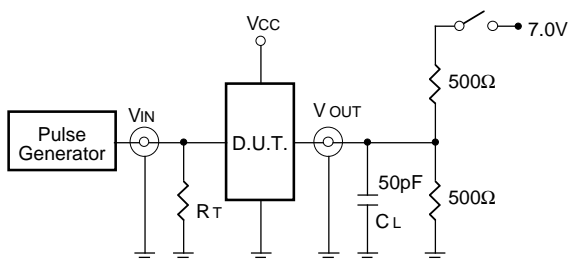

SWITCH POSITION

Test	Switch
Open Drain Disable Low Enable Low	Closed
All Other Tests	Open

DEFINITIONS:

CL = Load capacitance: includes jig and probe capacitance.

RT = Termination resistance: should be equal to ZOUT of the Pulse Generator.

2536 tbl 08

SET-UP, HOLD AND RELEASE TIMES

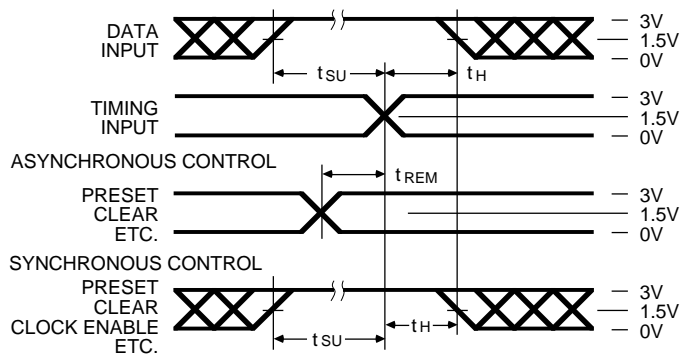

PULSE WIDTH

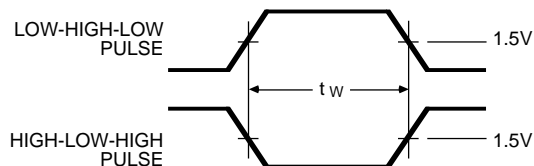

PROPAGATION DELAY

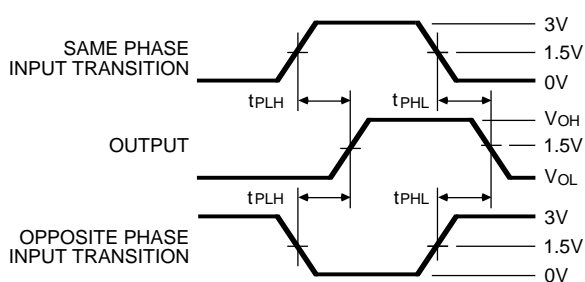

ENABLE AND DISABLE TIMES

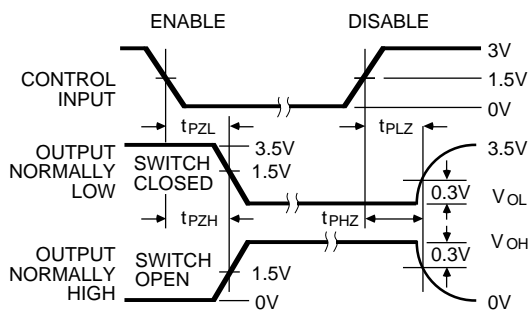

NOTES

2536 drw 07

- Diagram shown for input Control Enable-LOW and input Control Disable-HIGH.
- Pulse Generator for All Pulses: Rate ≤ 1.0 MHz; $Z_o \leq 50\Omega$; $t_r \leq 2.5$ ns; $t_f \leq 2.5$ ns.

ORDERING INFORMATION

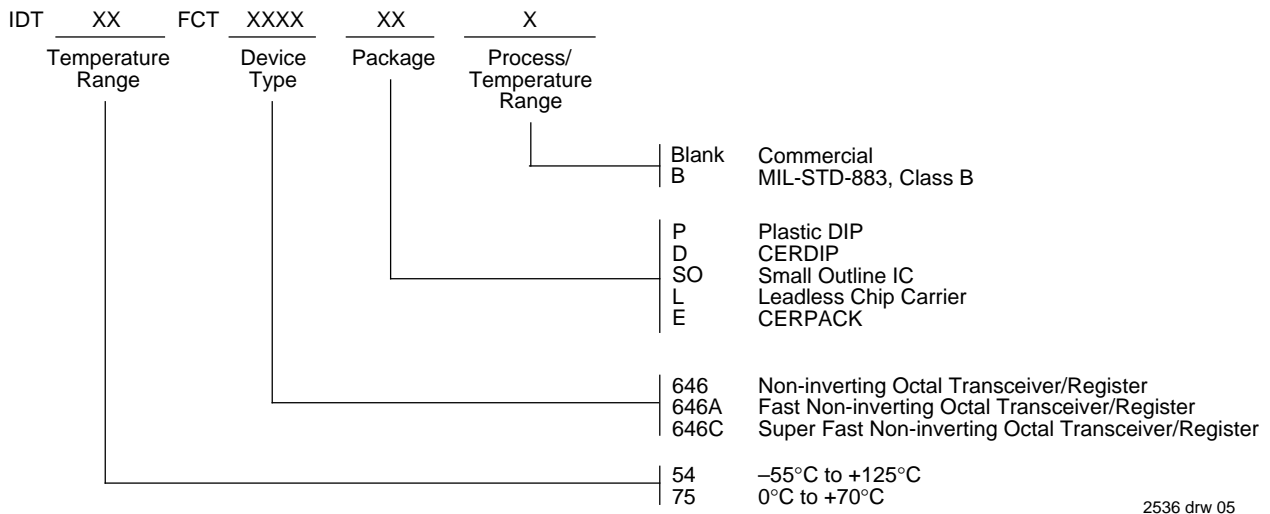

2536 drw 05