



Integrated Device Technology, Inc.

HIGH-SPEED 2K x 8 DUAL-PORT STATIC RAM WITH INTERRUPTS

IDT71321SA/LA
IDT71421SA/LA

FEATURES:

- High-speed access
 - Commercial: 20/25/35/45/55ns (max.)
- Low-power operation
 - IDT71321/IDT71421SA
 - Active: 550mW (typ.)
 - Standby: 5mW (typ.)
 - IDT71321/421LA
 - Active: 550mW (typ.)
 - Standby: 1mW (typ.)
- Two $\overline{\text{INT}}$ flags for port-to-port communications
- MASTER IDT71321 easily expands data bus width to 16-or-more-bits using SLAVE IDT71421
- On-chip port arbitration logic (IDT71321 only)
- $\overline{\text{BUSY}}$ output flag on IDT71321; $\overline{\text{BUSY}}$ input on IDT71421
- Fully asynchronous operation from either port
- Battery backup operation —2V data retention (LA Only)
- TTL-compatible, single 5V $\pm 10\%$ power supply
- Available in popular hermetic and plastic packages
- Industrial temperature range (-40°C to $+85^{\circ}\text{C}$) is available, tested to military electrical specifications

DESCRIPTION:

The IDT71321/IDT71421 are high-speed 2K x 8 Dual-Port Static RAMs with internal interrupt logic for interprocessor communications. The IDT71321 is designed to be used as a stand-alone 8-bit Dual-Port RAM or as a "MASTER" Dual-Port RAM together with the IDT71421 "SLAVE" Dual-Port in 16-bit-or-more word width systems. Using the IDT MASTER/SLAVE Dual-Port RAM approach in 16-or-more-bit memory system applications results in full speed, error-free operation without the need for additional discrete logic.

Both devices provide two independent ports with separate control, address, and I/O pins that permit independent, asynchronous access for reads or writes to any location in memory. An automatic power down feature, controlled by $\overline{\text{CE}}$, permits the on chip circuitry of each port to enter a very low standby power mode.

Fabricated using IDT's CMOS high-performance technology, these devices typically operate on only 550mW of power. Low-power (LA) versions offer battery backup data retention capability, with each Dual-Port typically consuming 200 μW from a 2V battery.

The IDT71321/IDT71421 devices are packaged in a 52-pin PLCC, a 64-pin TQFP, and a 64-pin STQFP.

FUNCTIONAL BLOCK DIAGRAM

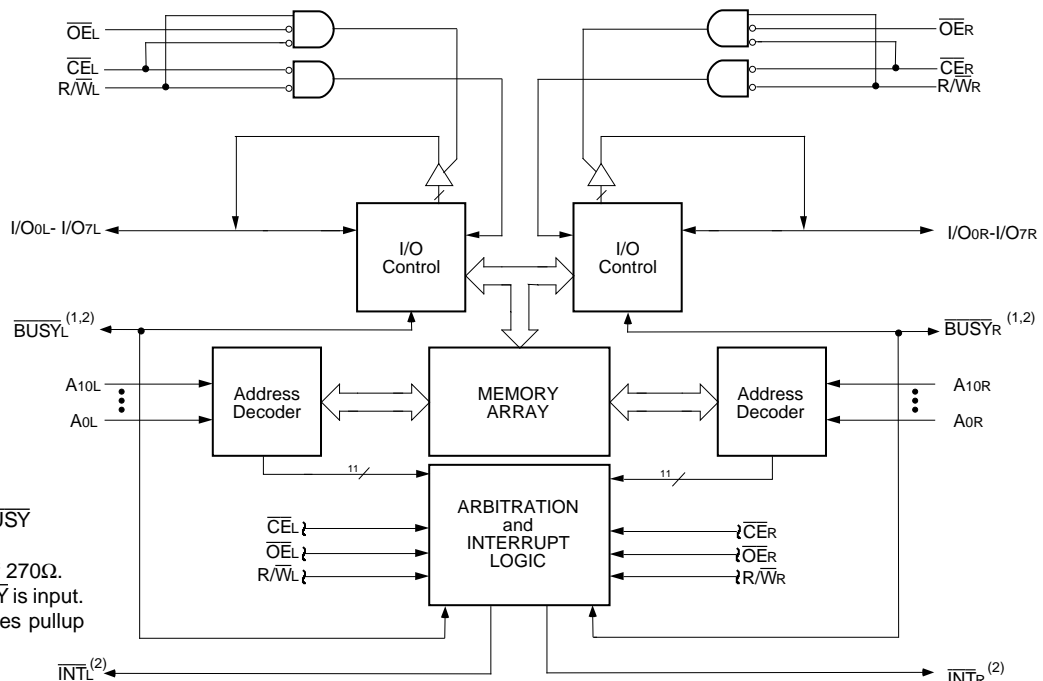

NOTES:

1. IDT71321 (MASTER): $\overline{\text{BUSY}}$ is open drain output and requires pullup resistor of 270 Ω . IDT71421 (SLAVE): $\overline{\text{BUSY}}$ is input.
2. Open drain output: requires pullup resistor of 270 Ω .

2691 drw 01

The IDT logo is a registered trademark of Integrated Device Technology, Inc.

COMMERCIAL TEMPERATURE RANGE

OCTOBER 1996

PIN CONFIGURATIONS (1,2)

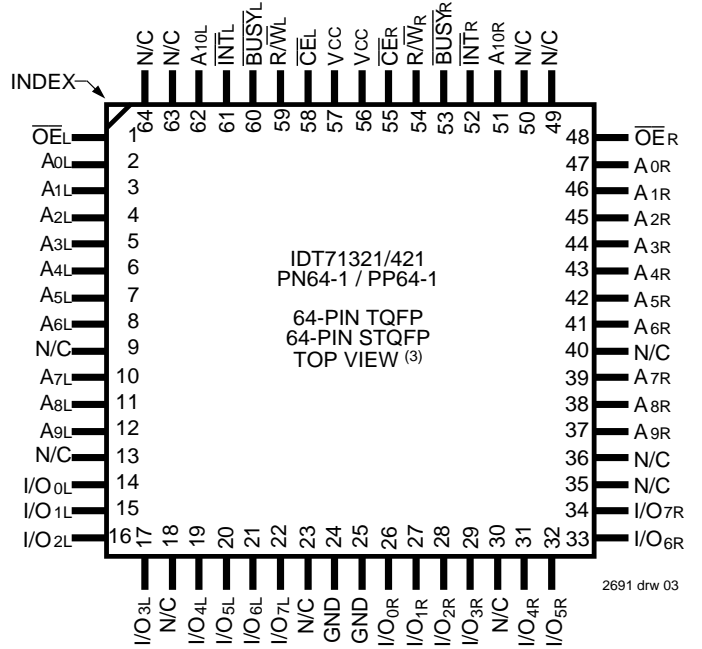
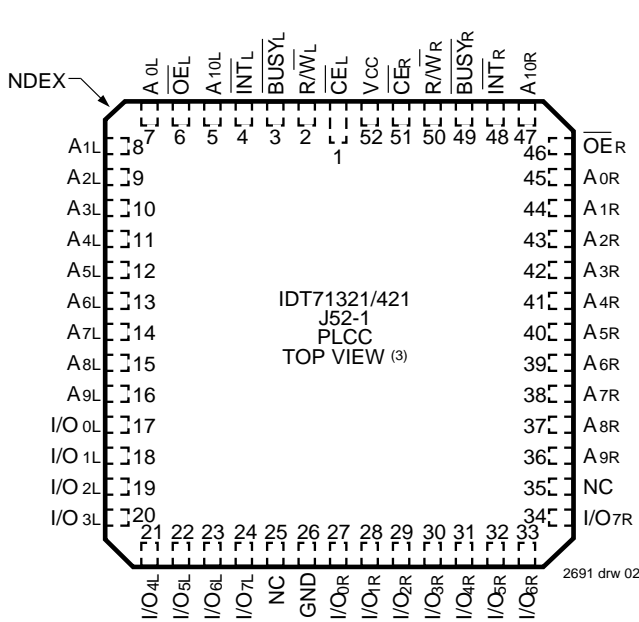

NOTES:

1. All Vcc pins must be connected to the power supply.
2. All GND pins must be connected to the ground supply.
3. This text does not indicate orientation of the actual part-marking.

ABSOLUTE MAXIMUM RATINGS(1)

Symbol	Rating	Commercial	Unit
VTERM(2)	Terminal Voltage with Respect to GND	-0.5 to +7.0	V
TA	Operating Temperature	0 to +70	°C
TBIAS	Temperature Under Bias	-55 to +125	°C
TSTG	Storage Temperature	-55 to +125	°C
IOUT	DC Output Current	50	mA

NOTES:

1. Stresses greater than those listed under ABSOLUTE MAXIMUM RATINGS may cause permanent damage to the device. This is a stress rating only and functional operation of the device at these or any other conditions above those indicated in the operational sections of the specification is not implied. Exposure to absolute maximum rating conditions for extended periods may affect reliability.
2. VTERM must not exceed Vcc + 0.5 for more than 25% of the cycle time or 10ns maximum, and is limited to ≤ 20mA for the period of VTERM ≥ Vcc + 0.5V.

RECOMMENDED OPERATING TEMPERATURE AND SUPPLY VOLTAGE

Grade	Ambient Temperature	GND	Vcc
Commercial	0°C to +70°C	0V	5.0V ± 10%

2691 tbl 02

RECOMMENDED DC OPERATING CONDITIONS

Symbol	Parameter	Min.	Typ.	Max.	Unit
Vcc	Supply Voltage	4.5	5.0	5.5	V
GND	Supply Voltage	0	0	0	V
VIH	Input High Voltage	2.2	—	6.0(2)	V
VIL	Input Low Voltage	-0.5(1)	—	0.8	V

NOTES:

1. VIL (min.) = -1.5V for pulse width less than 10ns.
2. VTERM must not exceed Vcc + 0.5V.

2691 tbl 03

CAPACITANCE(1,3)

(TA = +25°C, f = 1.0MHz) TQFP ONLY

Symbol	Parameter	Conditions(2)	Max.	Unit
CIN	Input Capacitance	VIN = 3dV	9	pF
COU	Output Capacitance	VIN = 3dV	10	pF

NOTES:

1. This parameter is determined by device characterization but is not production tested.
2. 3dv references the interpolated capacitance when the input and output signals switch from 0V to 3V or from 3V to 0V.
3. 11pF max. for other packages.

2691 tbl 04

DC ELECTRICAL CHARACTERISTICS OVER THE OPERATING TEMPERATURE AND SUPPLY VOLTAGE RANGE^(1,4) ($V_{CC} = 5.0V \pm 10\%$)

Symbol	Parameter	Test Conditions	Version	71321X20		71321X25 71421X25		71321X35 71421X35		71321X55 71421X55		71321X100 71421X100		Unit	
				Typ.	Max.	Typ.	Max.	Typ.	Max.	Typ.	Max.	Typ.	Max.		
I _{CC}	Dynamic Operating Current (Both Ports Active)	$\overline{CE}L$ and $\overline{CE}R = V_{IL}$, Outputs open, $f = f_{MAX}^{(2)}$	MIL.	SA	—	—	110	280	80	230	65	190	65	190	mA
				LA	—	—	110	220	80	170	65	140	65	140	
			COM'L.	SA	110	250	110	220	80	165	65	155	65	155	
LA	110	200		110	170	80	120	65	110	65	110				
I _{SB1}	Standby Current (Both Ports - TTL Level Inputs)	$\overline{CE}L$ and $\overline{CE}R = V_{IH}$, $f = f_{MAX}^{(2)}$	MIL.	SA	—	—	30	80	25	80	20	65	20	65	mA
				LA	—	—	30	60	25	60	20	45	20	45	
			COM'L.	SA	30	65	30	65	25	65	20	65	20	55	
LA	30	45		30	45	25	45	20	35	20	35				
I _{SB2}	Standby Current (One Port - TTL Level Inputs)	$\overline{CE}A^* = V_{IL}$ and $\overline{CE}B^* = V_{IH}^{(5)}$ Active Port Outputs Open, $f = f_{MAX}^{(2)}$	MIL.	SA	—	—	65	160	50	150	40	125	40	125	mA
				LA	—	—	65	125	50	115	40	90	40	90	
			COM'L.	SA	65	165	65	150	50	125	40	110	40	110	
LA	65	125		65	115	50	90	40	75	40	75				
I _{SB3}	Full Standby Current (Both Ports - All CMOS Level Inputs)	$\overline{CE}L$ and $\overline{CE}R \geq V_{CC} - 0.2V$, $V_{IN} \geq V_{CC} - 0.2V$ or $V_{IN} \leq 0.2V, f = 0^{(3)}$	MIL.	SA	—	—	1.0	30	1.0	30	1.0	30	1.0	30	mA
				LA	—	—	0.2	10	0.2	10	0.2	10	0.2	10	
			COM'L.	SA	1.0	15	1.0	15	1.0	15	1.0	15	1.0	15	
LA	0.2	5		0.2	5	0.2	4	0.2	4	0.2	4				
I _{SB4}	Full Standby Current (One Port - All CMOS Level Inputs)	$\overline{CE}A^* \leq 0.2V$ and $\overline{CE}B^* \geq V_{CC} - 0.2V^{(5)}$ $V_{IN} \geq V_{CC} - 0.2V$ or $V_{IN} \leq 0.2V$, Active Port Outputs Open, $f = f_{MAX}^{(2)}$	MIL.	SA	—	—	60	155	45	145	40	110	40	110	mA
				LA	—	—	60	115	45	105	40	85	40	80	
			COM'L.	SA	60	155	60	145	45	110	40	100	40	95	
LA	60	115		60	105	45	85	40	70	40	70				

NOTES:

2689 tbl 05

- 'X' in part numbers indicates power rating (SA or LA).
- At $f = f_{max}$, address and control lines (except Output Enable) are cycling at the maximum frequency read cycle of $1/trc$, and using "AC TEST CONDITIONS" of input levels of GND to 3V.
- $f = 0$ means no address or control lines change. Applies only to inputs at CMOS level standby.
- $V_{CC} = 5V$, $T_A = +25^\circ C$ for Typ. and is not production tested. $V_{CC DC} = 100mA$ (Typ)
- Port "A" may be either left or right port. Port "B" is opposite from port "A".

DC ELECTRICAL CHARACTERISTICS OVER THE OPERATING TEMPERATURE AND SUPPLY VOLTAGE RANGE ($V_{CC} = 5.0V \pm 10\%$)

Symbol	Parameter	Test Conditions	IDT71321SA IDT71421SA		IDT71321LA IDT71421LA		Unit
			Min.	Max.	Min.	Max.	
I _L	Input Leakage Current ⁽¹⁾	$V_{CC} = 5.5V$, $V_{IN} = 0V$ to V_{CC}	—	10	—	5	μA
I _{LO}	Output Leakage Current ⁽¹⁾	$\overline{CE} = V_{IH}$, $V_{OUT} = 0V$ to V_{CC} $V_{CC} = 5.5V$	—	10	—	5	μA
V _{OL}	Output Low Voltage (I/O ₀ -I/O ₇)	I _{OL} = 4mA	—	0.4	—	0.4	V
V _{OL}	Open Drain Output Low Voltage (BUSY, INT)	I _{OL} = 16mA	—	0.5	—	0.5	V
V _{OH}	Output High Voltage	I _{OH} = -4mA	2.4	—	2.4	—	V

NOTE: 1. At $V_{CC} \leq 2.0V$ leakages are undefined.

2691 tbl 06

DATA RETENTION CHARACTERISTICS (LA Version Only)

Symbol	Parameter	Test Conditions	71321LA/71421LA			Unit
			Min.	Typ. ⁽¹⁾	Max.	
VDR	VCC for Data Retention	VCC = 2.0V, $\overline{CE} \geq VCC - 0.2V$ VIN ≥ VCC - 0.2V or VIN ≤ 0.2V	2.0	—	0	V
ICDDR	Data Retention Current		—	100	1500	μA
tCDR ⁽³⁾	Chip Deselect to Data Retention Time		0	—	—	ns
tR ⁽³⁾	Operation Recovery Time		tRC ⁽²⁾	—	—	ns

NOTES:

- VCC = 2V, TA = +25°C, and is not production tested.
- tRC = Read Cycle Time
- This parameter is guaranteed by device characterization but not production tested.

2691 tbl 07

DATA RETENTION WAVEFORM

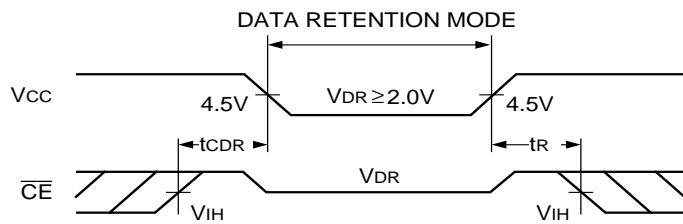

2691 drw 04

AC TEST CONDITIONS

Input Pulse Levels	GND to 3.0V
Input Rise/Fall Times	5ns
Input Timing Reference Levels	1.5V
Output Reference Levels	1.5V
Output Load	Figures 1, 2, and 3

2691 tbl 08

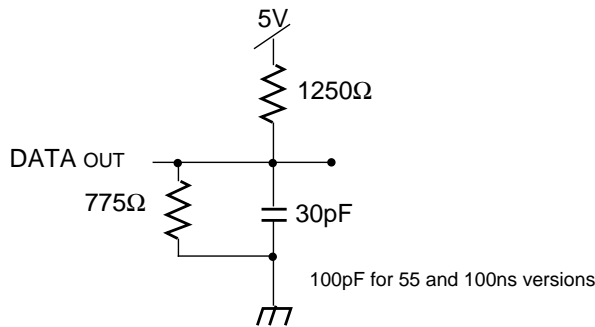

Figure 1. AC Output Test Load

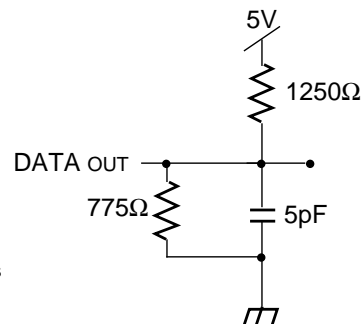

Figure 2. Output Test Load (for tHZ, tLZ, twz, and tow)

* Including scope and jig.

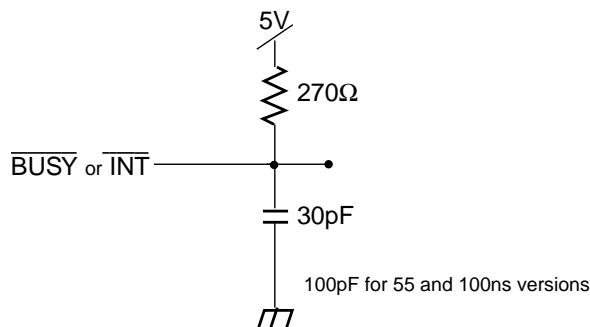

Figure 3. \overline{BUSY} and \overline{INT} AC Output Test Load

2691 drw 05

AC ELECTRICAL CHARACTERISTICS OVER THE OPERATING TEMPERATURE AND SUPPLY VOLTAGE RANGE⁽²⁾

Symbol	Parameter	71321X20		71321X25 71421X25		71321X35 71421X35		71321X55 71421X55		71321X100 71421X100		Unit
		Min.	Max.	Min.	Max.	Min.	Max.	Min.	Max.	Min.	Max.	
Read Cycle												
t _{RC}	Read Cycle Time	20	—	25	—	35	—	55	—	100	—	ns
t _{AA}	Address Access Time	—	20	—	25	—	35	—	55	—	100	ns
t _{ACE}	Chip Enable Access Time	—	20	—	25	—	35	—	55	—	100	ns
t _{AOE}	Output Enable Access Time	—	11	—	12	—	20	—	25	—	40	ns
t _{OH}	Output Hold From Address Change	3	—	3	—	3	—	3	—	10	—	ns
t _{LZ}	Output Low-Z Time ^(1,3)	0	—	0	—	0	—	5	—	5	—	ns
t _{HZ}	Output High-Z Time ^(1,3)	—	10	—	10	—	15	—	25	—	40	ns
t _{PU}	Chip Enable to Power Up Time ⁽³⁾	0	—	0	—	0	—	0	—	0	—	ns
t _{PD}	Chip Disable to Power Down Time ⁽³⁾	—	20	—	25	—	35	—	50	—	50	ns

NOTES:

2689 tbl 09

1. Transition is measured $\pm 500\text{mV}$ from Low or High-impedance voltage Output Test Load (Figure 2).
2. "X" in part numbers indicates power rating (SA or LA).
3. This parameter is guaranteed by device characterization, but is not production tested.

TIMING WAVEFORM OF READ CYCLE NO. 1, EITHER SIDE ⁽¹⁾

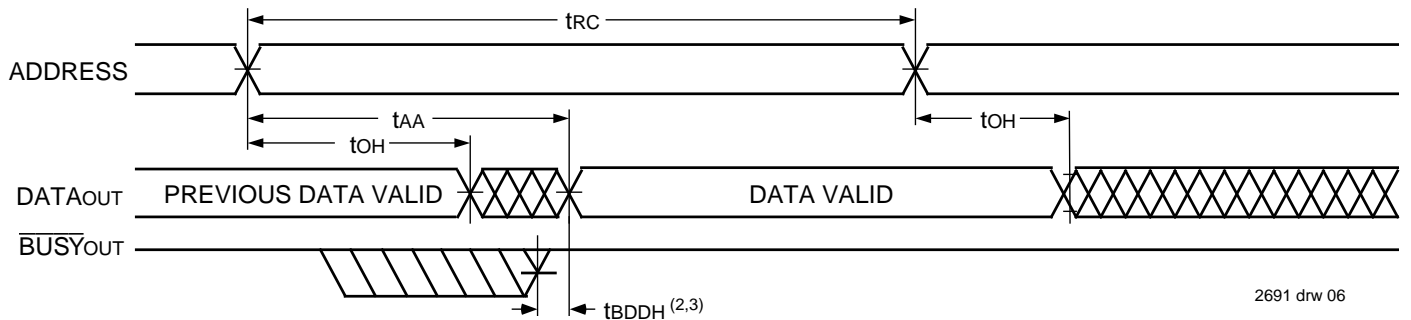

2691 drw 06

NOTES:

1. $R/\bar{W} = V_{IH}$, $\bar{CE} = V_{IL}$, and $\bar{OE} = V_{IL}$. Address is valid prior to or coincidental with \bar{CE} transition Low.
2. t_{BDD} delay is required only in the case where the opposite port is completing a write operation to the same address location. For simultaneous read operations \bar{BUSY} has no relationship to valid output data.
3. Start of valid data depends on which timing becomes effective last t_{AOE} , t_{ACE} , t_{AA} , and t_{BDD} .

TIMING WAVEFORM OF READ CYCLE NO. 2, EITHER SIDE (3)

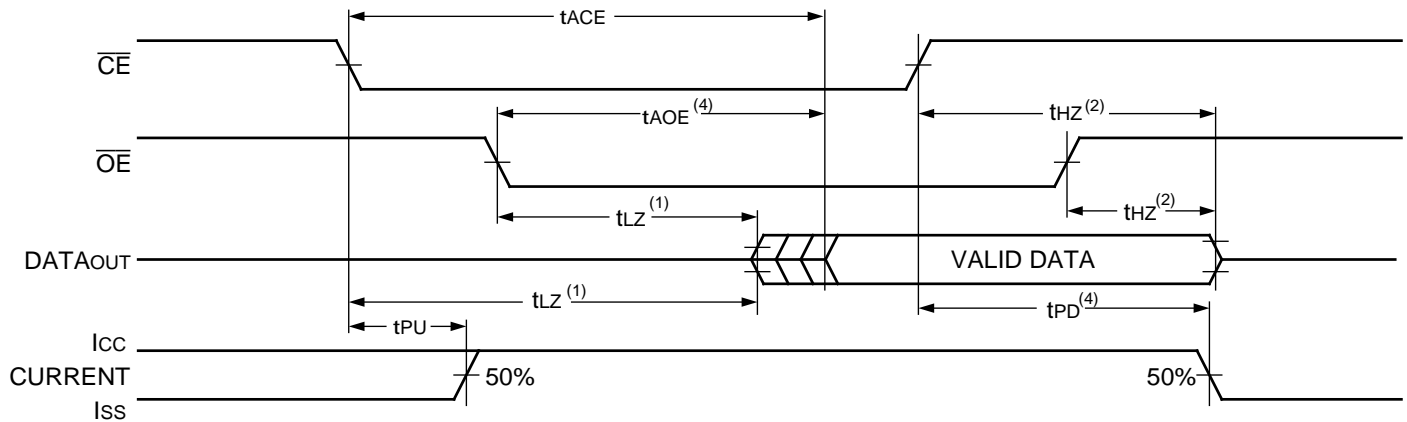

2691 drw 07

NOTES:

1. Timing depends on which signal is asserted last, \overline{OE} or \overline{CE} .
2. Timing depends on which signal is deasserted first, \overline{OE} or \overline{CE} .
3. $R/\overline{W} = V_{IH}$ and the address is valid prior to or coincidental with \overline{CE} transition Low.
4. Start of valid data depends on which timing becomes effective last t_{AOE} , t_{ACE} , t_{AA} , and t_{BDD} .

AC ELECTRICAL CHARACTERISTICS OVER THE OPERATING TEMPERATURE AND SUPPLY VOLTAGE RANGE(4)

Symbol	Parameter	71321X20		71321X25 71421X25		71321X35 71421X35		71321X55 71421X55		71321X100 71421X100		Unit
		Min.	Max.	Min.	Max.	Min.	Max.	Min.	Max.	Min.	Max.	
Write Cycle												
tWC	Write Cycle Time ⁽²⁾	20	—	25	—	35	—	55	—	100	—	ns
tEW	Chip Enable to End of Write	15	—	20	—	30	—	40	—	90	—	ns
tAW	Address Valid to End of Write	15	—	20	—	30	—	40	—	90	—	ns
tAS	Address Set-up Time	0	—	0	—	0	—	0	—	0	—	ns
tWP	Write Pulse Width ⁽³⁾	15	—	15	—	25	—	30	—	55	—	ns
tWR	Write Recovery Time	0	—	0	—	0	—	0	—	0	—	ns
tDW	Data Valid to End of Write	10	—	12	—	15	—	20	—	40	—	ns
tHZ	Output High-Z Time ⁽¹⁾	—	10	—	10	—	15	—	25	—	40	ns
tDH	Data Hold Time	0	—	0	—	0	—	0	—	0	—	ns
twZ	Write Enabled to Output in High-Z ⁽¹⁾	—	10	—	10	—	15	—	30	—	40	ns
tOW	Output Active From End of Write ⁽¹⁾	0	—	0	—	0	—	0	—	0	—	ns

2692 tbl 10

NOTES:

1. Transition is measured $\pm 500\text{mV}$ from Low or High-impedance voltage with Output Test Load (Figure 2). This parameter is guaranteed by device characterization but is not production tested.
2. For Master/Slave combination, $t_{WC} = t_{BAA} + t_{WP}$, since $R/\overline{W} = V_{IL}$ must occur after t_{BAA} .
3. If \overline{OE} is low during a R/\overline{W} controlled write cycle, the write pulse width must be the larger of t_{WP} or $(t_{wZ} + t_{DW})$ to allow the I/O drivers to turn off data to be placed on the bus for the required t_{DW} . If \overline{OE} is High during a R/\overline{W} controlled write cycle, this requirement does not apply and the write pulse can be as short as the specified t_{WP} .
4. "X" in part numbers indicates power rating (SA or LA).

TIMING WAVEFORM OF WRITE CYCLE NO. 1, ($\overline{R/\overline{W}}$ CONTROLLED TIMING)^(1,5,8)

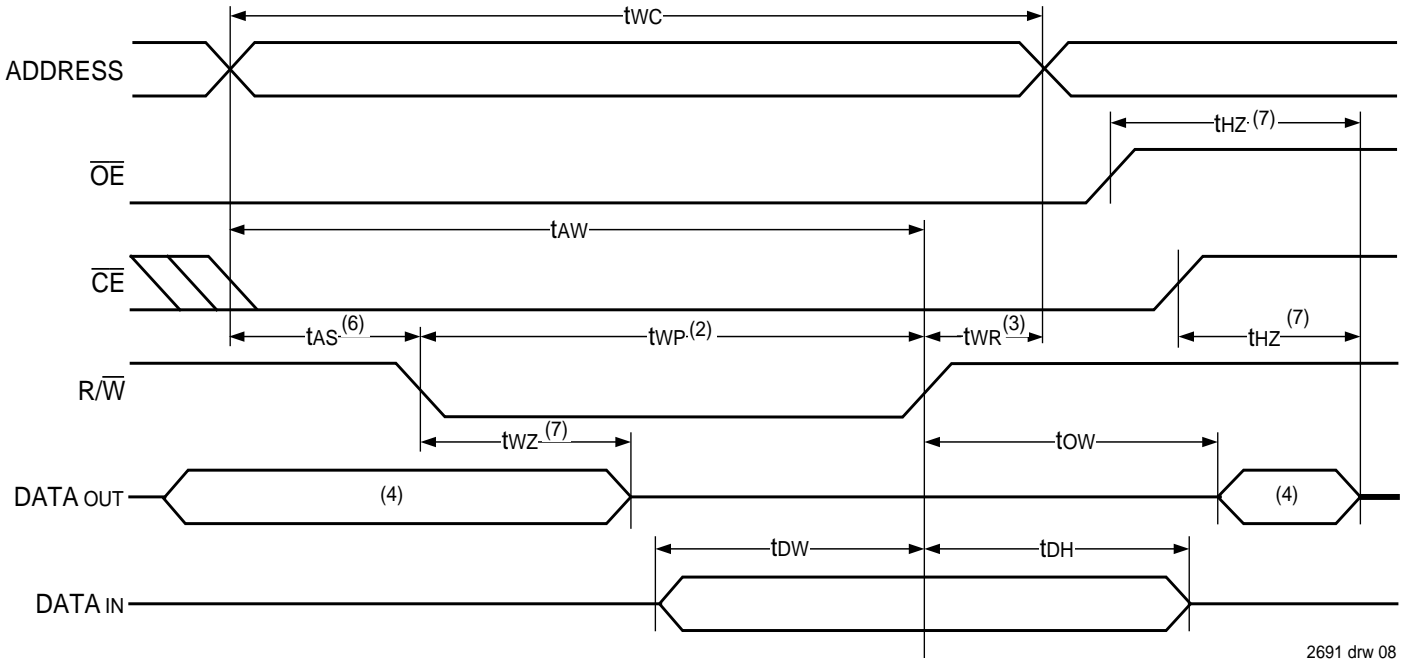

2691 drw 08

TIMING WAVEFORM OF WRITE CYCLE NO. 2, (\overline{CE} CONTROLLED TIMING)^(1,5)

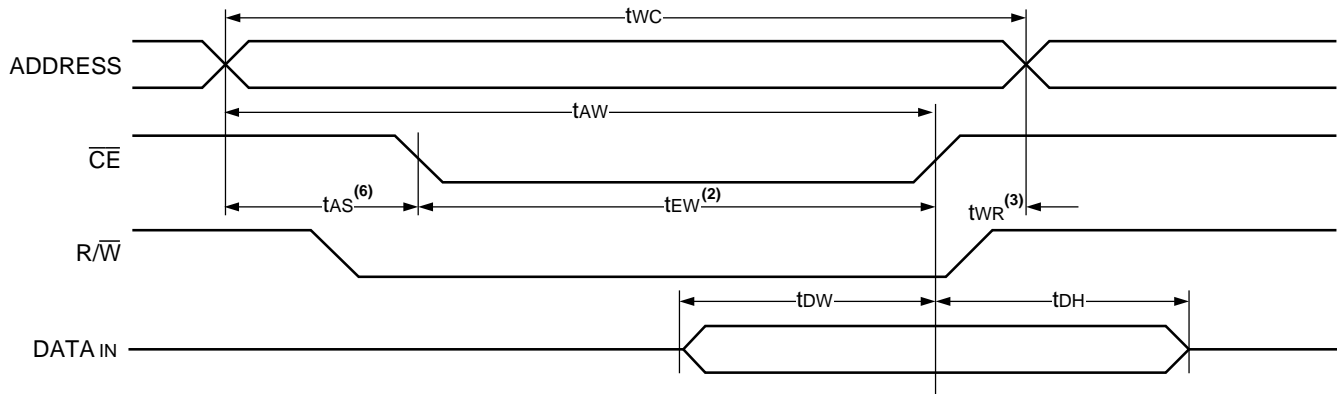

NOTES:

1. $\overline{R/\overline{W}}$ or \overline{CE} must be High during all address transitions.
2. A write occurs during the overlap (t_{EW} or t_{WP}) of $\overline{CE} = V_{IL}$ and $\overline{R/\overline{W}} = V_{IL}$.
3. t_{WR} is measured from the earlier of \overline{CE} or $\overline{R/\overline{W}}$ going High to the end of the write cycle.
4. During this period, the I/O pins are in the output state and input signals must not be applied.
5. If the \overline{CE} Low transition occurs simultaneously with or after the $\overline{R/\overline{W}}$ Low transition, the outputs remain in the High-impedance state.
6. Timing depends on which enable signal (\overline{CE} or $\overline{R/\overline{W}}$) is asserted last.
7. This parameter is determined by device characterization, but is not production tested. Transition is measured +/- 500mV from steady state with the Output Test Load (Figure 2).
8. If \overline{OE} is Low during a $\overline{R/\overline{W}}$ controlled write cycle, the write pulse width must be the larger of t_{WP} or $(t_{WZ} + t_{DW})$ to allow the I/O drivers to turn off data to be placed on the bus for the required t_{DW} . If \overline{OE} is High during a $\overline{R/\overline{W}}$ controlled write cycle, this requirement does not apply and the write pulse can be as short as the specified t_{WP} .

2691 drw 09

AC ELECTRICAL CHARACTERISTICS OVER THE OPERATING TEMPERATURE AND SUPPLY VOLTAGE RANGE⁽⁶⁾

Symbol	Parameter	71321X20		71321X25 71421X25		71321X35 71421X35		71321X55 71421X55		71321X100 71421X100		Unit
		Min.	Max.	Min.	Max.	Min.	Max.	Min.	Max.	Min.	Max.	
Busy Timing (For Master IDT71321 Only)												
tBAA	$\overline{\text{BUSY}}$ Access Time from Address	—	20	—	20	—	20	—	30	—	50	ns
tBDA	$\overline{\text{BUSY}}$ Disable Time from Address	—	20	—	20	—	20	—	30	—	50	ns
tBAC	$\overline{\text{BUSY}}$ Access Time from Chip Enable	—	20	—	20	—	20	—	30	—	50	ns
tBDC	$\overline{\text{BUSY}}$ Disable Time from Chip Enable	—	20	—	20	—	20	—	30	—	50	ns
tWH	Write Hold After $\overline{\text{BUSY}}$ ⁽⁵⁾	12	—	15	—	20	—	20	—	20	—	ns
tWDD	Write Pulse to Data Delay ⁽¹⁾	—	50	—	50	—	60	—	80	—	120	ns
tDDD	Write Data Valid to Read Data Delay ⁽¹⁾	—	35	—	35	—	35	—	55	—	100	ns
tAPS	Arbitration Priority Set-up Time ⁽²⁾	5	—	5	—	5	—	5	—	5	—	ns
tBDD	$\overline{\text{BUSY}}$ Disable to Valid Data ⁽³⁾	—	25	—	35	—	35	—	50	—	65	ns
Busy Timing (For Slave IDT71421 Only)												
tWB	Write to $\overline{\text{BUSY}}$ Input ⁽⁴⁾	0	—	0	—	0	—	0	—	0	—	ns
tWH	Write Hold After $\overline{\text{BUSY}}$ ⁽⁵⁾	12	—	15	—	20	—	20	—	20	—	ns
tWDD	Write Pulse to Data Delay ⁽¹⁾	—	40	—	50	—	60	—	80	—	120	ns
tDDD	Write Data Valid to Read Data Delay ⁽¹⁾	—	30	—	35	—	35	—	55	—	100	ns

NOTES:

2689 tbl 11

1. Port-to-port delay through RAM cells from the writing port to the reading port, refer to "Timing Waveform of Write with Port-to-Port Read and $\overline{\text{BUSY}}$."
2. To ensure that the earlier of the two ports wins.
3. tBDD is a calculated parameter and is the greater of 0, tWDD – tWP (actual), or tDDD – tDW (actual).
4. To ensure that a write cycle is inhibited on port 'B' during contention on port 'A'.
5. To ensure that a write cycle is completed on port 'B' after contention on port 'A'.
6. "X" in part numbers indicates power rating (S or L).

TIMING WAVEFORM OF WRITE WITH PORT-TO-PORT READ AND $\overline{\text{BUSY}}$ ^(2,3,4)

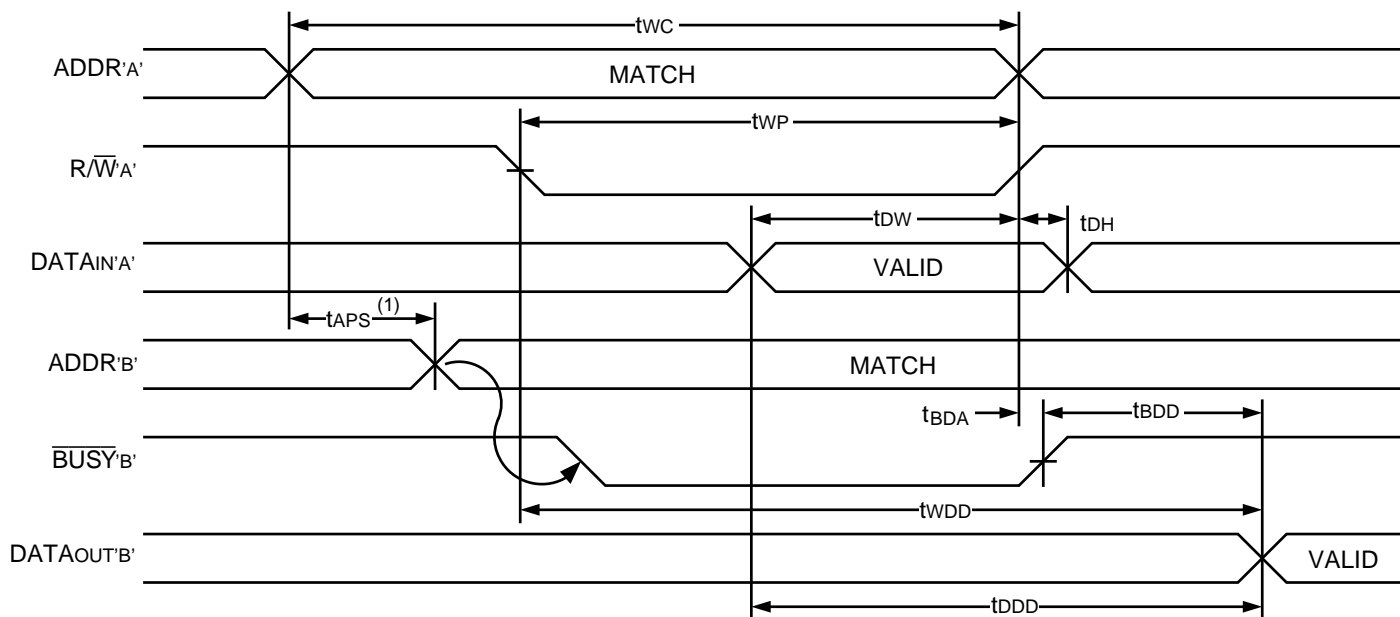

NOTES:

2691 drw 10

1. To ensure that the earlier of the two ports wins. tAPS is ignored for Slave (IDT71421).
2. $\overline{\text{CE}}_L = \overline{\text{CE}}_R = V_{IL}$.
3. $\overline{\text{OE}} = V_{IL}$ for the reading port.
4. All timing is the same for the left and right ports. Port 'A' may be either the left or right port. Port 'B' is opposite from port 'A'.

TIMING WAVEFORM OF WRITE WITH $\overline{\text{BUSY}}^{(3)}$

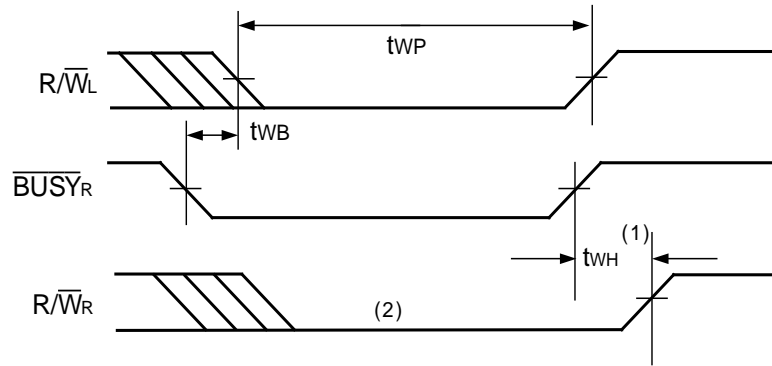

2691 drw 11

NOTES:

1. t_{WH} must be met for both $\overline{\text{BUSY}}$ Input (IDT71421, slave) or Output (IDT71321, master).
2. $\overline{\text{BUSY}}$ is asserted on port 'B' blocking $\text{R}/\overline{\text{W}}_{\text{B}}$, until $\overline{\text{BUSY}}_{\text{B}}$ goes High.
3. All timing is the same for the left and right ports. Port 'A' may be either the left or right port. Port 'B' is opposite from port 'A'.

TIMING WAVEFORM OF BUSY ARBITRATION CONTROLLED BY $\overline{\text{CE}}$ TIMING ⁽¹⁾

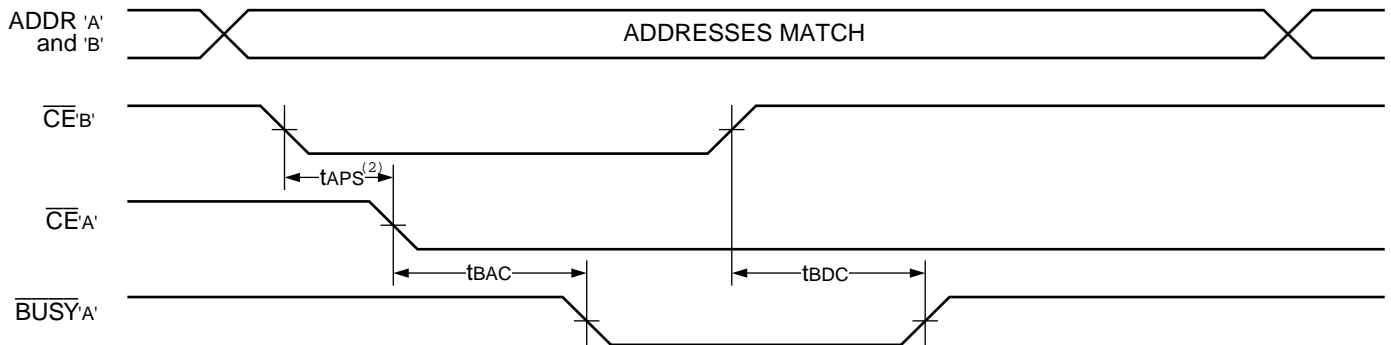

2691 drw 12

TIMING WAVEFORM OF BUSY ARBITRATION CONTROLLED BY ADDRESS MATCH TIMING ⁽¹⁾

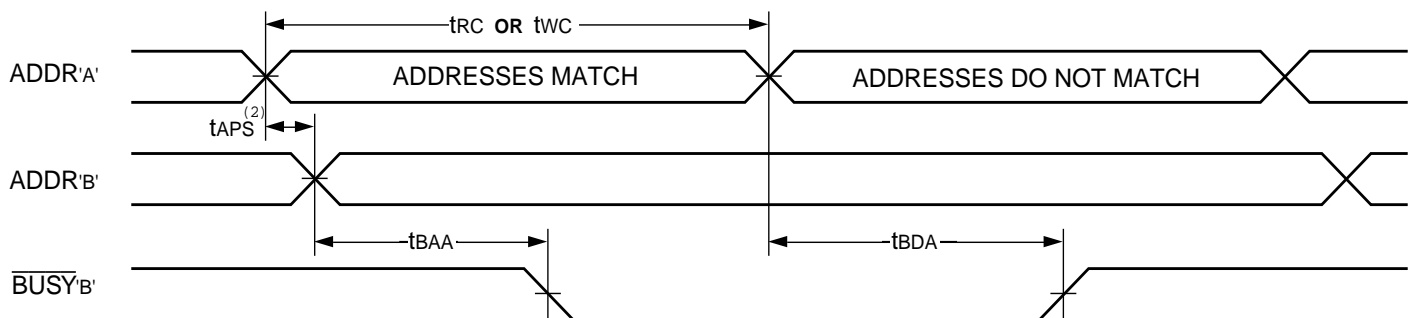

2691 drw 13

NOTES:

1. All timing is the same for left and right ports. Port 'A' may be either left or right port. Port 'B' is the opposite from port 'A'.
2. If t_{APS} is not satisfied, the $\overline{\text{BUSY}}$ will be asserted on one side or the other, but there is no guarantee on which side $\overline{\text{BUSY}}$ will be asserted (71321 only).

AC ELECTRICAL CHARACTERISTICS OVER THE OPERATING TEMPERATURE AND SUPPLY VOLTAGE RANGE⁽¹⁾

Symbol	Parameter	71321X25 71421X25		71321X35 71421X35		71321X45 71421X45		71321X55 71421X55		Unit
		Min.	Max.	Min.	Max.	Min.	Max.	Min.	Max.	
Interrupt Timing										
tAS	Address Set-up Time	0	—	0	—	0	—	0	—	ns
tWR	Write Recovery Time	0	—	0	—	0	—	0	—	ns
tINS	Interrupt Set Time	—	25	—	25	—	35	—	45	ns
tINR	Interrupt Reset Time	—	25	—	25	—	35	—	45	ns

NOTE:

2689 tbl 12

1. "X" in part numbers indicates power rating (S or L).

TIMING WAVEFORM OF INTERRUPT MODE

SET $\overline{\text{INT}}$

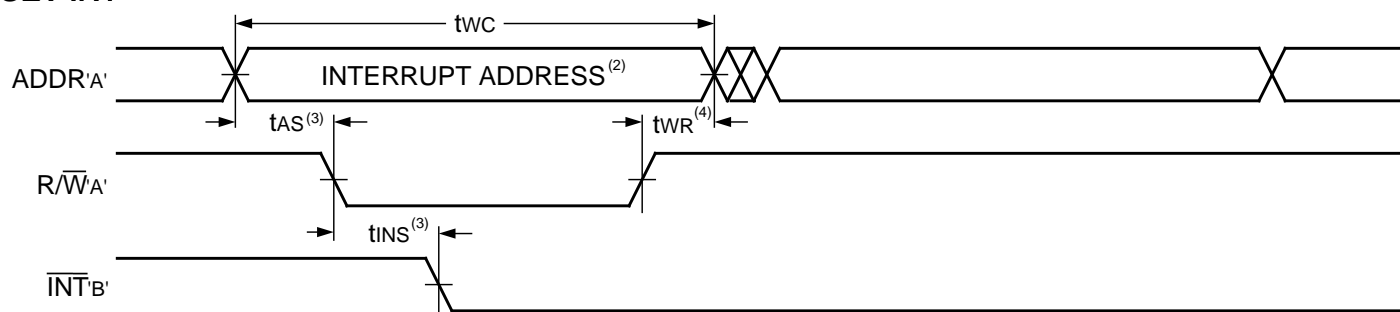

2691 drw 14

CLEAR $\overline{\text{INT}}$

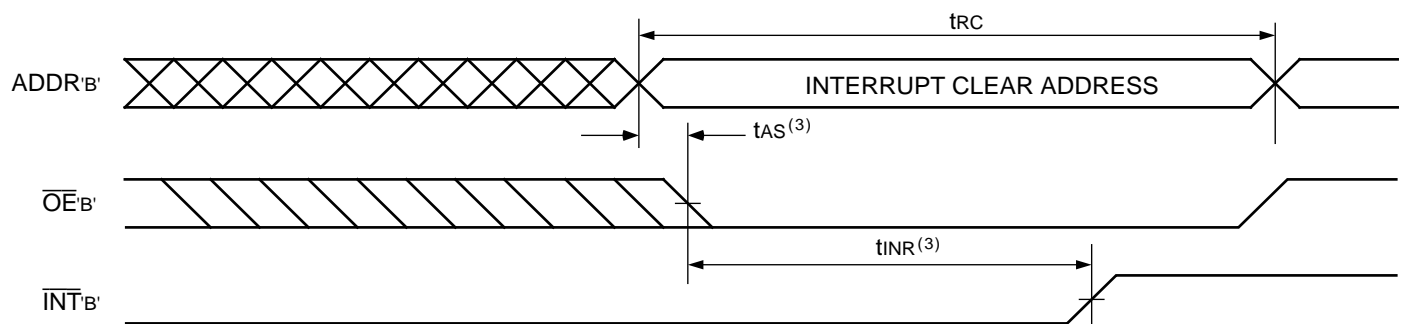

2691 drw 15

NOTES:

1. All timing is the same for left and right ports. Port 'A' may be either left or right port. Port 'B' is the opposite from port 'A'.
2. See Interrupt Truth Table.
3. Timing depends on which enable signal ($\overline{\text{CE}}$ or $\text{R}/\overline{\text{W}}$) is asserted last.
4. Timing depends on which enable signal ($\overline{\text{CE}}$ or $\text{R}/\overline{\text{W}}$) is de-asserted first.

TRUTH TABLES

**TABLE I —
NON-CONTENTION READ/WRITE CONTROL⁽⁴⁾**

Left or Right Port ⁽¹⁾				Function
R/W	\overline{CE}	\overline{OE}	D ₀₋₇	
X	H	X	Z	Port Disabled and in Power-Down Mode, ISB2 or ISB4
X	H	X	Z	$\overline{CE_R} = \overline{CE_L} = V_{IH}$, Power-Down Mode, ISB1 or ISB3
L	L	X	DATA _{IN}	Data on Port Written Into Memory ⁽²⁾
H	L	L	DATA _{OUT}	Data in Memory Output on Port ⁽³⁾
H	L	H	Z	High-impedance Outputs

NOTES:

2654 tbl 13

1. A_{0L} – A_{10L} ≠ A_{0R} – A_{10R}.
2. If $\overline{BUSY} = V_{IL}$, data is not written.
3. If $\overline{BUSY} = V_{IL}$, data may not be valid, see t_{WDD} and t_{DD} timing.
4. 'H' = V_{IH}, 'L' = V_{IL}, 'X' = DON'T CARE, 'Z' = High-impedance.

TABLE II — INTERRUPT FLAG^(1,4)

Left Port					Right Port					Function
R/W _L	$\overline{CE_L}$	$\overline{OE_L}$	A _{10L} – A _{0L}	$\overline{INT_L}$	R/W _R	$\overline{CE_R}$	$\overline{OE_R}$	A _{10L} – A _{0R}	$\overline{INT_R}$	
L	L	X	7FF	X	X	X	X	X	L ⁽²⁾	Set Right $\overline{INT_R}$ Flag
X	X	X	X	X	X	L	L	7FF	H ⁽³⁾	Reset Right $\overline{INT_R}$ Flag
X	X	X	X	L ⁽³⁾	L	L	X	7FE	X	Set Left $\overline{INT_L}$ Flag
X	L	L	7FE	H ⁽²⁾	X	X	X	X	X	Reset Left $\overline{INT_L}$ Flag

NOTES:

2654 tbl 14

1. Assumes $\overline{BUSY_L} = \overline{BUSY_R} = V_{IH}$
2. If $\overline{BUSY_L} = V_{IL}$, then No Change.
3. If $\overline{BUSY_R} = V_{IL}$, then No Change.
4. 'H' = V_{IH}, 'L' = V_{IL}, 'X' = DON'T CARE.

TABLE III — ADDRESS BUSY ARBITRATION

Inputs			Outputs		Function
$\overline{CE_L}$	$\overline{CE_R}$	A _{0L} -A _{10L} A _{0R} -A _{10R}	$\overline{BUSY_L}^{(1)}$	$\overline{BUSY_R}^{(1)}$	
X	X	NO MATCH	H	H	Normal
H	X	MATCH	H	H	Normal
X	H	MATCH	H	H	Normal
L	L	MATCH	(2)	(2)	Write Inhibit ⁽³⁾

NOTES:

2689 tbl 15

1. Pins $\overline{BUSY_L}$ and $\overline{BUSY_R}$ are both outputs for IDT71321 (master). Both are inputs for IDT71421 (slave). \overline{BUSY}_x outputs on the IDT71321 are open drain, not push-pull outputs. On slaves the \overline{BUSY}_x input internally inhibits writes.
2. 'L' if the inputs to the opposite port were stable prior to the address and enable inputs of this port. 'H' if the inputs to the opposite port became stable after the address and enable inputs of this port. If t_{APS} is not met, either $\overline{BUSY_L}$ or $\overline{BUSY_R} = \text{Low}$ will result. $\overline{BUSY_L}$ and $\overline{BUSY_R}$ outputs can not be low simultaneously.
3. Writes to the left port are internally ignored when $\overline{BUSY_L}$ outputs are driving Low regardless of actual logic level on the pin. Writes to the right port are internally ignored when $\overline{BUSY_R}$ outputs are driving Low regardless of actual logic level on the pin.

FUNCTIONAL DESCRIPTION

The IDT71321/IDT71421 provides two ports with separate control, address and I/O pins that permit independent access for reads or writes to any location in memory. The IDT71321/IDT71421 has an automatic power down feature controlled by \overline{CE} . The \overline{CE} controls on-chip power down circuitry that permits the respective port to go into a standby mode when not selected ($\overline{CE} = V_{IH}$). When a port is enabled, access to the entire memory array is permitted.

INTERRUPTS

If the user chooses to use the interrupt function, a memory location (mail box or message center) is assigned to each port. The left port interrupt flag (\overline{INTL}) is asserted when the right port writes to memory location 7FE (HEX), where a write is defined as the $\overline{CE} = R/\overline{W} = V_{IL}$ per the Truth Table. The left port clears the interrupt by access address location 7FE access when $\overline{CER} = \overline{OER} = V_{IL}$, R/\overline{W} is a "Don't Care". Likewise, the right port interrupt flag (\overline{INTR}) is asserted when the left port writes to memory location 7FF (HEX) and to clear the interrupt flag (\overline{INTR}), the right port must access the memory location 7FF. The message (8 bits) at 7FE or 7FF is user-defined, since it is an addressable SRAM location. If the interrupt function is not used, address locations 7FE and 7FF are not used as mail boxes, but as part of the random access memory. Refer to Table I for the interrupt operation.

BUSY LOGIC

Busy Logic provides a hardware indication that both ports of the RAM have accessed the same location at the same time. It also allows one of the two accesses to proceed and signals the other side that the RAM is "Busy". The Busy pin can then be used to stall the access until the operation on the other side is completed. If a write operation has been attempted from the side that receives a busy indication, the write signal is gated internally to prevent the write from proceeding. The use of busy logic is not required or desirable for all applications. In some cases it may be useful to logically OR the busy outputs together and use any busy indication as an interrupt source to flag the event of an illegal or illogical operation. In slave mode the \overline{BUSY} pin operates solely as a write inhibit input pin. Normal operation can be programmed by tying the \overline{BUSY} pins High. If desired, unintended write operations can be prevented to a port by tying the Busy pin for that port Low.

The Busy outputs on the IDT71321 RAM (Master) are open drain type outputs and require open drain resistors to operate. If these RAMs are being expanded in depth, then the Busy indication for the resulting array does not require the use of an external AND gate.

WIDTH EXPANSION WITH BUSY LOGIC MASTER/SLAVE ARRAYS

When expanding an RAM array in width while using busy logic, one master part is used to decide which side of the RAM array will receive a busy indication, and to output that indication. Any number of slaves to be addressed in the same address range as the master, use the busy signal as a write inhibit signal. Thus on the IDT71321/IDT71421 RAMs the Busy pin is an output if the part is Master (IDT71321), and the Busy pin is an input if the part is a Slave (IDT71421) as shown in Figure 4.

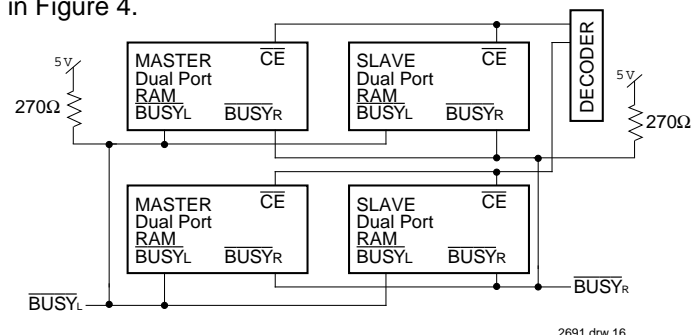

2691 drw 16
Figure 4. Busy and chip enable routing for both width and depth expansion with IDT71321 (Master) and (Slave) IDT71421 RAMs.

If two or more master parts were used when expanding in width, a split decision could result with one master indicating busy on one side of the array and another master indicating busy on one other side of the array. This would inhibit the write operations from one port for part of a word and inhibit the write operations from the other port for the other part of the word.

The Busy arbitration, on a Master, is based on the chip enable and address signals only. It ignores whether an access is a read or write. In a master/slave array, both address and chip enable must be valid long enough for a busy flag to be output from the master before the actual write pulse can be initiated with either the R/\overline{W} signal or the byte enables. Failure to observe this timing can result in a glitched internal write inhibit signal and corrupted data in the slave.

ORDERING INFORMATION

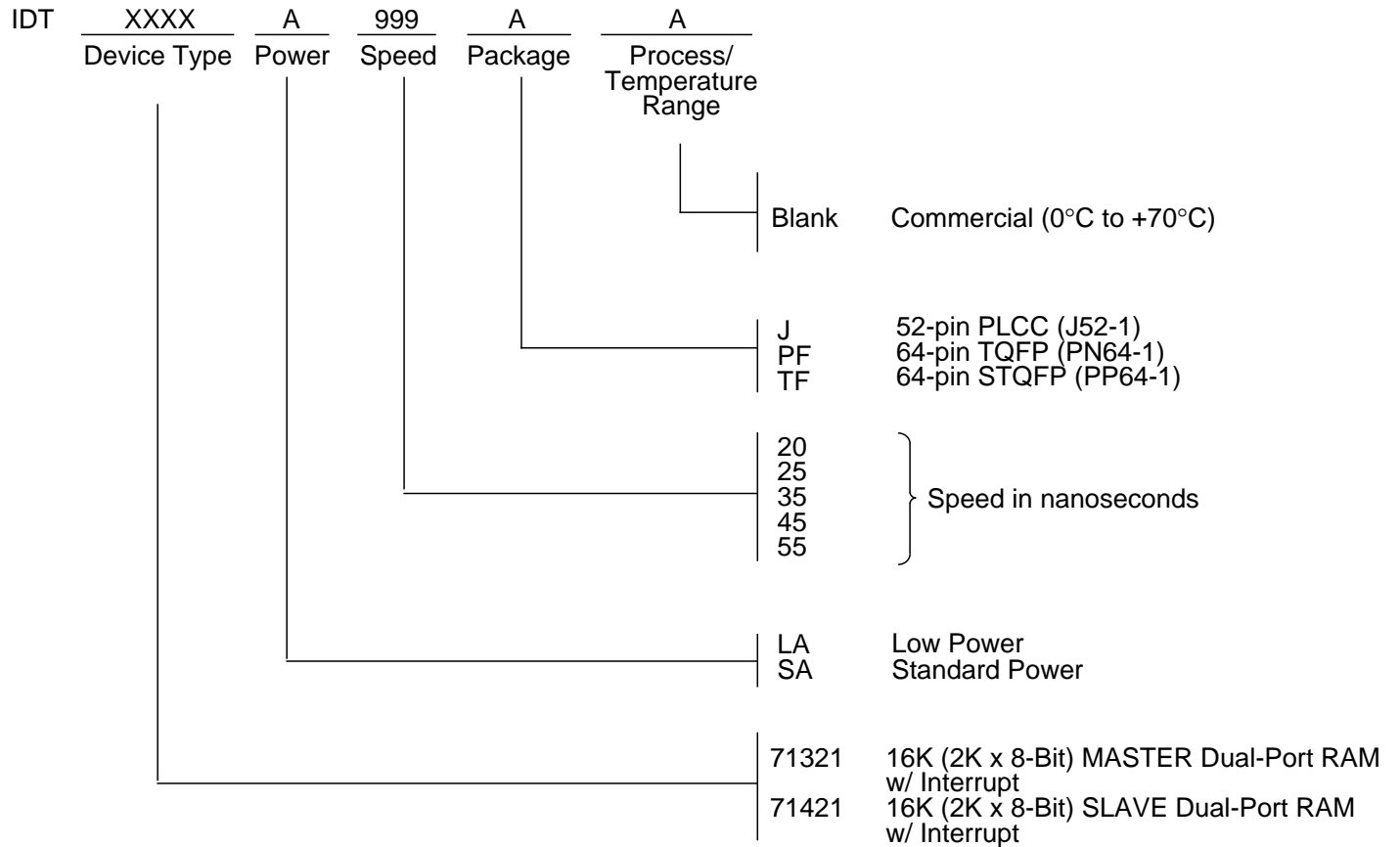

2691 drw 17