



Integrated Device Technology, Inc.

3.3V CMOS OCTAL BUFFER/LINE DRIVER

IDT54/74FCT3244/A

FEATURES:

- 0.5 MICRON CMOS Technology
- ESD > 2000V per MIL-STD-883, Method 3015; > 200V using machine model (C = 200pF, R = 0)
- 25 mil Center SSOP and QSOP Packages
- Extended commercial range of -40°C to +85°C
- VCC = 3.3V ±0.3V, Normal Range or VCC = 2.7V to 3.6V, Extended Range
- CMOS power levels (0.4μW typ. static)
- Rail-to-Rail output swing for increased noise margin
- Military product compliant to MIL-STD-883, Class B

DESCRIPTION:

The FCT3244/A octal buffer/line drivers are built using advanced dual metal CMOS technology. These high-speed, low-power buffers are designed to be used as memory data and address drivers, clock drivers, and bus-oriented transmitter/receivers. The three-state controls are designed to operate these devices in a dual-nibble or single-byte mode. All inputs are designed with hysteresis for improved noise margin.

FUNCTIONAL BLOCK DIAGRAM

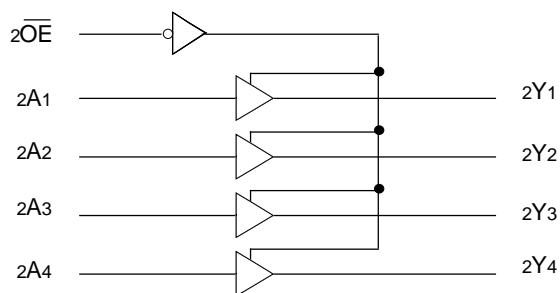
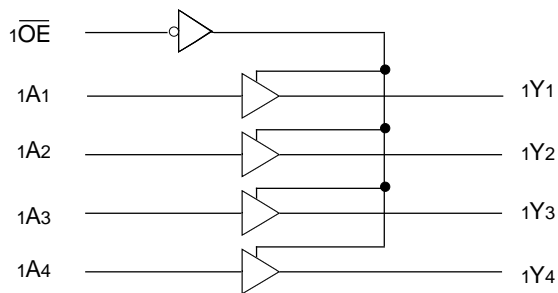

2779 drw 01

PIN CONFIGURATIONS

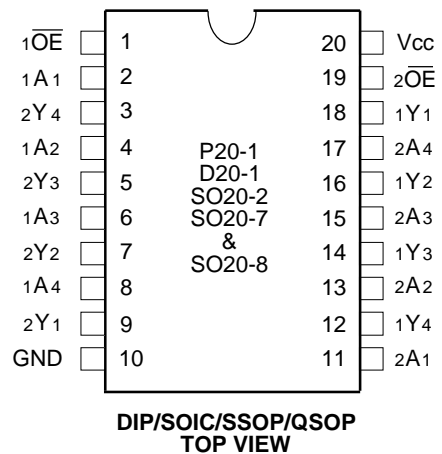

2779 drw 02

The IDT logo is a registered trademark of Integrated Device Technology, Inc.

MILITARY AND COMMERCIAL TEMPERATURE RANGES

DECEMBER 1995

PIN DESCRIPTION

Pin Names	Description
\overline{xOE}	3-State Output Enable Inputs (Active LOW)
xAx	Data Inputs
xYx	3-State Outputs

2779 tbl 01

FUNCTION TABLE⁽¹⁾

Inputs		Outputs
\overline{xOE}	xAx	xYx
L	L	L
L	H	H
H	X	Z

2779 tbl 02

NOTE:

- 1. H = HIGH Voltage Level
- X = Don't Care
- L = LOW Voltage Level
- Z = High Impedance

ABSOLUTE MAXIMUM RATINGS⁽¹⁾

Symbol	Rating	Commercial	Military	Unit
$V_{TERM}^{(2)}$	Terminal Voltage with Respect to GND	-0.5 to +4.6	-0.5 to +4.6	V
$V_{TERM}^{(3)}$	Terminal Voltage with Respect to GND	-0.5 to +7.0	-0.5 to +7.0	V
$V_{TERM}^{(4)}$	Terminal Voltage with Respect to GND	-0.5 to $V_{CC} + 0.5$	-0.5 to $V_{CC} + 0.5$	V
T_A	Operating Temperature	-40 to +85	-55 to +125	°C
T_{BIAS}	Temperature Under Bias	-55 to +125	-65 to +135	°C
T_{STG}	Storage Temperature	-55 to +125	-65 to +150	°C
P_T	Power Dissipation	1.0	1.0	W
I_{OUT}	DC Output Current	-60 to +60	-60 to +60	mA

2779 Ink 03

NOTES:

- 1. Stresses greater than those listed under ABSOLUTE MAXIMUM RATINGS may cause permanent damage to the device. This is a stress rating only and functional operation of the device at these or any other conditions above those indicated in the operational sections of this specification is not implied. Exposure to absolute maximum rating conditions for extended periods may affect reliability.
- 2. V_{CC} terminals.
- 3. Input terminals.
- 4. Output and I/O terminals.

CAPACITANCE ($T_A = +25^\circ\text{C}$, $f = 1.0\text{MHz}$)

Symbol	Parameter ⁽¹⁾	Conditions	Typ.	Max.	Unit
C_{IN}	Input Capacitance	$V_{IN} = 0V$	3.5	6.0	pF
C_{OUT}	Output Capacitance	$V_{OUT} = 0V$	4.0	8.0	pF

2779 Ink 04

NOTE:

- 1. This parameter is measured at characterization but not tested.

DC ELECTRICAL CHARACTERISTICS OVER OPERATING RANGE

Following Conditions Apply Unless Otherwise Specified:

Commercial: $T_A = -40^{\circ}\text{C}$ to $+85^{\circ}\text{C}$, $V_{CC} = 2.7\text{V}$ to 3.6V ; Military: $T_A = -55^{\circ}\text{C}$ to $+125^{\circ}\text{C}$, $V_{CC} = 2.7\text{V}$ to 3.6V

Symbol	Parameter	Test Conditions ⁽¹⁾		Min.	Typ. ⁽²⁾	Max.	Unit
V_{IH}	Input HIGH Level (Input pins)	Guaranteed Logic HIGH Level		2.0	—	5.5	V
	Input HIGH Level (I/O pins)			2.0	—	$V_{CC}+0.5$	
V_{IL}	Input LOW Level (Input and I/O pins)	Guaranteed Logic LOW Level		-0.5	—	0.8	V
I_{IH}	Input HIGH Current (Input pins) ⁽⁶⁾	$V_{CC} = \text{Max.}$	$V_I = 5.5\text{V}$	—	—	± 1	μA
	Input HIGH Current (I/O pins) ⁽⁶⁾		$V_I = V_{CC}$	—	—	± 1	
I_{IL}	Input LOW Current (Input pins) ⁽⁶⁾		$V_I = \text{GND}$	—	—	± 1	
	Input LOW Current (I/O pins) ⁽⁶⁾		$V_I = \text{GND}$	—	—	± 1	
I_{OZH}	High Impedance Output Current	$V_{CC} = \text{Max.}$	$V_O = V_{CC}$	—	—	± 1	μA
I_{OZL}	(3-State Output pins) ⁽⁶⁾		$V_O = \text{GND}$	—	—	± 1	
V_{IK}	Clamp Diode Voltage	$V_{CC} = \text{Min.}, I_{IN} = -18\text{mA}$		—	-0.7	-1.2	V
I_{ODH}	Output HIGH Current	$V_{CC} = 3.3\text{V}, V_{IN} = V_{IH}$ or $V_{IL}, V_O = 1.5\text{V}^{(3)}$		-36	-60	-110	mA
I_{ODL}	Output LOW Current	$V_{CC} = 3.3\text{V}, V_{IN} = V_{IH}$ or $V_{IL}, V_O = 1.5\text{V}^{(3)}$		50	90	200	mA
V_{OH}	Output HIGH Voltage	$V_{CC} = \text{Min.}$ $V_{IN} = V_{IH}$ or V_{IL}	$I_{OH} = -0.1\text{mA}$	$V_{CC}-0.2$	—	—	V
			$I_{OH} = -3\text{mA}$	2.4	3.0	—	
		$V_{CC} = 3.0\text{V}$ $V_{IN} = V_{IH}$ or V_{IL}	$I_{OH} = -6\text{mA MIL.}$ $I_{OH} = -8\text{mA COM'L.}$	2.4 ⁽⁵⁾	3.0	—	
V_{OL}	Output LOW Voltage	$V_{CC} = \text{Min.}$ $V_{IN} = V_{IH}$ or V_{IL}	$I_{OL} = 0.1\text{mA}$	—	—	0.2	V
			$I_{OL} = 16\text{mA}$	—	0.2	0.4	
		$I_{OL} = 24\text{mA}$	—	0.3	0.55		
		$V_{CC} = 3.0\text{V}$ $V_{IN} = V_{IH}$ or V_{IL}	$I_{OL} = 24\text{mA}$	—	0.3	0.50	
I_{OS}	Short Circuit Current ⁽⁴⁾	$V_{CC} = \text{Max.}, V_O = \text{GND}^{(3)}$		-60	-135	-240	mA
V_H	Input Hysteresis	—		—	150	—	mV
I_{CCL} I_{CCH} I_{CCZ}	Quiescent Power Supply Current	$V_{CC} = \text{Max.},$ $V_{IN} = \text{GND}$ or V_{CC}	COM'L.	—	0.1	10	μA
	MIL.		—	0.1	100		

2779 Ink 05

NOTES:

- For conditions shown as Max. or Min., use appropriate value specified under Electrical Characteristics for the applicable device type.
- Typical values are at $V_{CC} = 3.3\text{V}, +25^{\circ}\text{C}$ ambient.
- Not more than one output should be tested at one time. Duration of the test should not exceed one second.
- This parameter is guaranteed but not tested.
- $V_{OH} = V_{CC} - 0.6\text{V}$ at rated current.
- The test limits for this parameter is $\pm 5\mu\text{A}$ at $T_A = -55^{\circ}\text{C}$.

POWER SUPPLY CHARACTERISTICS

Symbol	Parameter	Test Conditions ⁽¹⁾		Min.	Typ. ⁽²⁾	Max.	Unit
ΔI_{CC}	Quiescent Power Supply Current	$V_{CC} = \text{Max.}$	$V_{IN} = V_{CC} - 0.6V^{(3)}$	—	2.0	30	μA
I_{CCD}	Dynamic Power Supply Current ⁽⁴⁾	$V_{CC} = \text{Max.}$ Outputs Open 50% Duty Cycle $\overline{xOE} = \text{GND}$ One Input Toggling	$V_{IN} = V_{CC}$ $V_{IN} = \text{GND}$	—	60	85	$\mu A/\text{MHz}$
I_C	Total Power Supply Current ⁽⁶⁾	$V_{CC} = \text{Max.}$ Outputs Open $f_i = 10\text{MHz}$ 50% Duty Cycle $\overline{xOE} = \text{GND}$ One Bit Toggling	$V_{IN} = V_{CC}$ $V_{IN} = \text{GND}$	—	0.6	0.9	mA
			$V_{IN} = V_{CC} - 0.6V$ $V_{IN} = \text{GND}$	—	0.6	0.9	
		$V_{CC} = \text{Max.}$ Outputs Open $f_i = 2.5\text{MHz}$ 50% Duty Cycle $\overline{xOE} = \text{GND}$ Eight Bits Toggling	$V_{IN} = V_{CC}$ $V_{IN} = \text{GND}$	—	1.2	1.7 ⁽⁵⁾	
			$V_{IN} = V_{CC} - 0.6V$ $V_{IN} = \text{GND}$	—	1.2	1.8 ⁽⁵⁾	

NOTES:

2779 tbl 06

- For conditions shown as max. or min., use appropriate value specified under Electrical Characteristics for the applicable device type.
- Typical values are at $V_{CC} = 3.3V$, $+25^\circ C$ ambient.
- Per TTL driven input; all other inputs at V_{CC} or GND.
- This parameter is not directly testable, but is derived for use in Total Power Supply Calculations.
- Values for these conditions are examples of the I_{CC} formula. These limits are guaranteed but not tested.
- $I_C = I_{QUIESCENT} + I_{INPUTS} + I_{DYNAMIC}$
 $I_C = I_{CC} + \Delta I_{CC} D_H N_T + I_{CCD} (f_{CP} N_{CP} / 2 + f_i N_i)$
 $I_{CC} = \text{Quiescent Current (Iccl, Iccch and Iccz)}$
 $\Delta I_{CC} = \text{Power Supply Current for a TTL High Input}$
 $D_H = \text{Duty Cycle for TTL Inputs High}$
 $N_T = \text{Number of TTL Inputs at } D_H$
 $I_{CCD} = \text{Dynamic Current Caused by an Input Transition Pair (HLH or LHL)}$
 $f_{CP} = \text{Clock Frequency for Register Devices (Zero for Non-Register Devices)}$
 $N_{CP} = \text{Number of Clock Inputs at } f_{CP}$
 $f_i = \text{Input Frequency}$
 $N_i = \text{Number of Inputs at } f_i$

SWITCHING CHARACTERISTICS OVER OPERATING RANGE⁽³⁾

Symbol	Parameter	Condition ⁽¹⁾	FCT3244				FCT3244A				Unit
			Com'l.		Mil.		Com'l.		Mil.		
			Min. ⁽²⁾	Max.	Min. ⁽²⁾	Max.	Min. ⁽²⁾	Max.	Min. ⁽²⁾	Max.	
t_{PLH} t_{PHL}	Propagation Delay xAx to xYx	$CL = 50pF$ $RL = 500\Omega$	1.5	6.5	1.5	7.0	1.5	4.8	1.5	5.1	ns
t_{PZH} t_{PZL}	Output Enable Time		1.5	8.0	1.5	8.5	1.5	6.2	1.5	6.5	ns
t_{PHZ} t_{PLZ}	Output Disable Time		1.5	7.0	1.5	7.5	1.5	5.6	1.5	5.9	ns

NOTES:

2779 tbl 07

- See test circuit and waveforms.
- Minimum limits are guaranteed but not tested on Propagation Delays.
- Propagation Delays and Enable/Disable times are with $V_{CC} = 3.3V \pm 0.3V$, Normal Range. For $V_{CC} = 2.7V$ to $3.6V$, Extended Range, all Propagation Delays and Enable/Disable times should be degraded by 20%.

TEST CIRCUITS AND WAVEFORMS

TEST CIRCUITS FOR ALL OUTPUTS

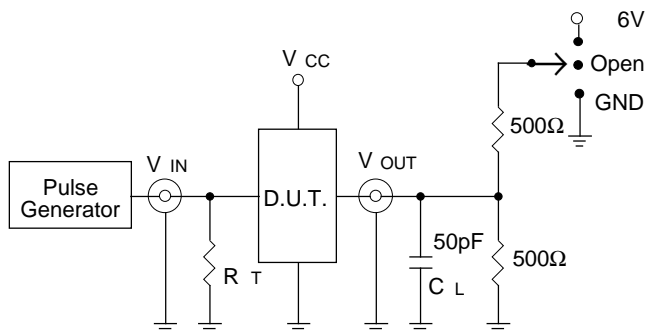

2779 drw 03

SWITCH POSITION

Test	Switch
Open Drain Disable Low Enable Low	6V
Disable High Enable High	GND
All Other tests	Open

DEFINITIONS:

C_L = Load capacitance: includes jig and probe capacitance.
 R_T = Termination resistance: should be equal to Z_{OUT} of the Pulse Generator.

2779 Ink 08

SET-UP, HOLD AND RELEASE TIMES

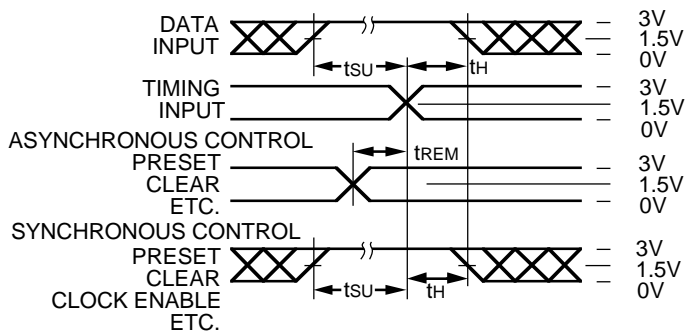

2779 drw 04

PULSE WIDTH

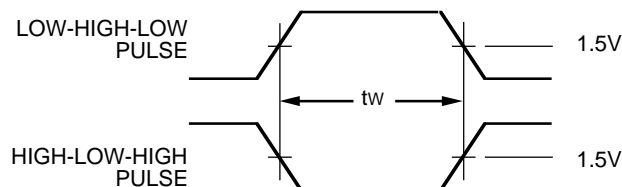

2779 drw 05

PROPAGATION DELAY

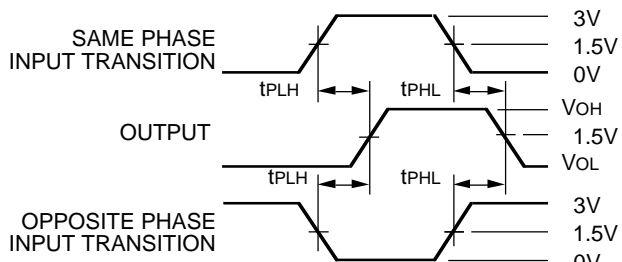

2779 drw 06

ENABLE AND DISABLE TIMES

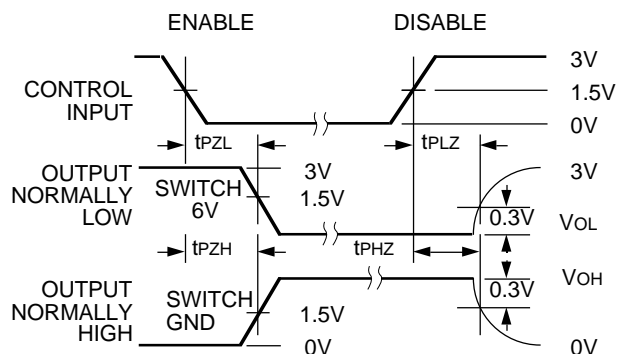

2779 drw 07

NOTES:

1. Diagram shown for input Control Enable-LOW and input Control Disable-HIGH.
2. Pulse Generator for All Pulses: Rate $\leq 1.0\text{MHz}$; $t_r \leq 2.5\text{ns}$; $t_f \leq 2.5\text{ns}$.
3. If V_{CC} is below 3V, input voltage swings should be adjusted not to exceed V_{CC} .

ORDERING INFORMATION

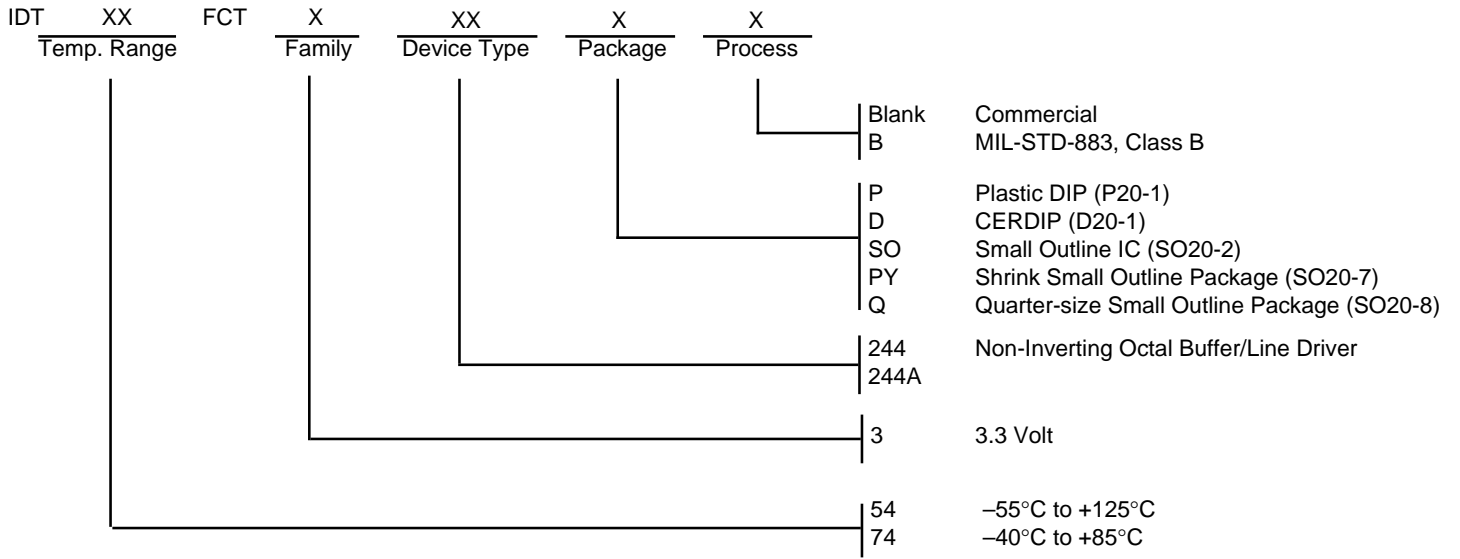

2779 drw 08