



Integrated Device Technology, Inc.

FAST CMOS 12-BIT SYNCHRONOUS BUS EXCHANGER

IDT54/74FCT162H272AT/CT/ET

FEATURES:

- 0.5 MICRON CMOS Technology
- **Typical tsk(o) (Output Skew) < 250ps**
- **Low input and output leakage $\leq 1\mu\text{A}$ (max.)**
- ESD > 2000V per MIL-STD-883, Method 3015; > 200V using machine model (C = 200pF, R = 0)
- Packages include 25 mil pitch SSOP, 19.6 mil pitch TSSOP, 15.7 mil pitch TVSOP and 25 mil pitch Cerpack
- Extended commercial range of -40°C to +85°C
- Balanced Output Drivers: $\pm 24\text{mA}$ (commercial)
 $\pm 16\text{mA}$ (military)
- Reduced system switching noise
- Typical VOLP (Output Ground Bounce) < 0.6V at VCC = 5V, TA = 25°C
- Bus Hold retains last active bus state during 3-state
- Eliminates the need for external pull up resistors

DESCRIPTION:

The FCT162H272AT/CT/ET synchronous tri-port bus exchangers are high-speed, bidirectional, 12-bit, registered, bus

multiplexers for use in synchronous memory interleaving applications. All registers have a common clock and use a clock enable ($\overline{\text{CE}}_{\text{xxx}}$) on each data register to control data sequencing. The output enables and mux select (OEA , OEB and SEL) are also under synchronous control allowing direction changes to be edge triggered events.

The tri-port bus exchanger has three 12-bit ports. Data may be transferred between the A port and either/both of the B ports. The clock enable ($\overline{\text{CE}}_{1\text{B}}$, $\overline{\text{CE}}_{2\text{B}}$, $\overline{\text{CE}}_{\text{A1B}}$ and $\overline{\text{CE}}_{\text{A2B}}$) inputs control the data storage. Both B ports have a common output enable ($\overline{\text{OEB}}$) to aid in synchronously loading the B registers from the B port.

The FCT162H272AT/CT/ET have balanced output drive with current limiting resistors. This offers low ground bounce, minimal undershoot, and controlled output fall times-reducing the need for external series terminating resistors.

The FCT162H272AT/CT/ET have "Bus Hold" which retains the input's last state whenever the input goes to high impedance. This prevents "floating" inputs and eliminates the need for pull-up/down resistors.

FUNCTIONAL BLOCK DIAGRAM

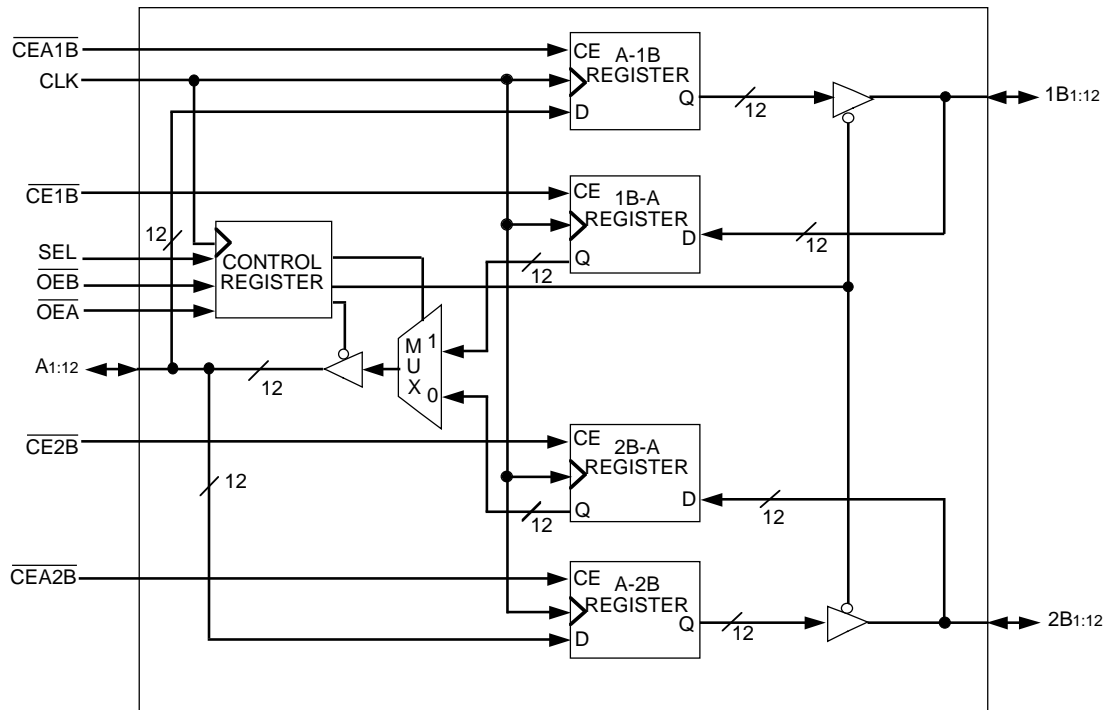

3071 drw 01

The IDT logo is a registered trademark of Integrated Device Technology, Inc.

MILITARY AND COMMERCIAL TEMPERATURE RANGES

AUGUST 1996

PIN CONFIGURATIONS

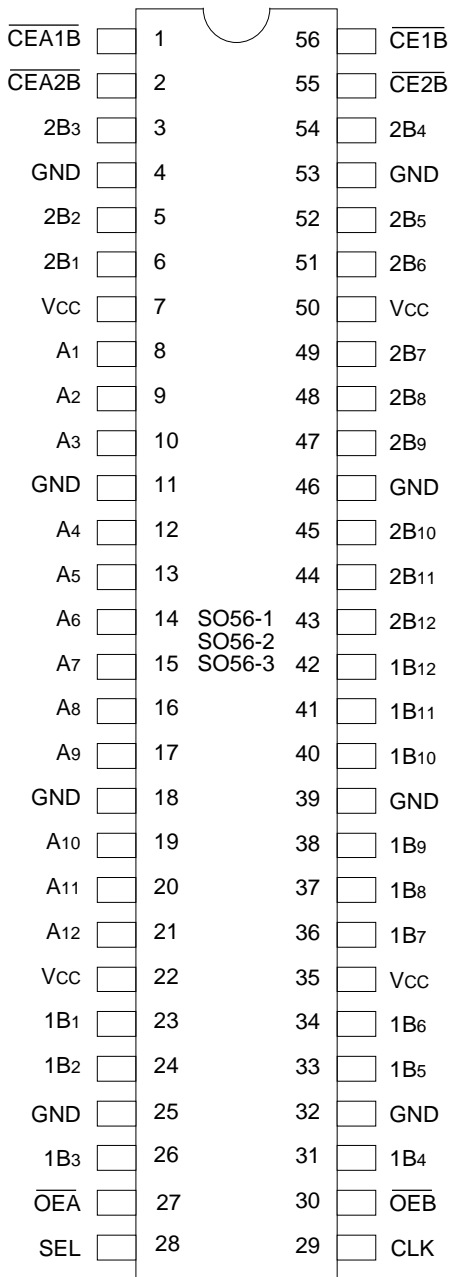

**SSOP/
 TSSOP/TVSOP
 TOP VIEW**

3071 drw 02

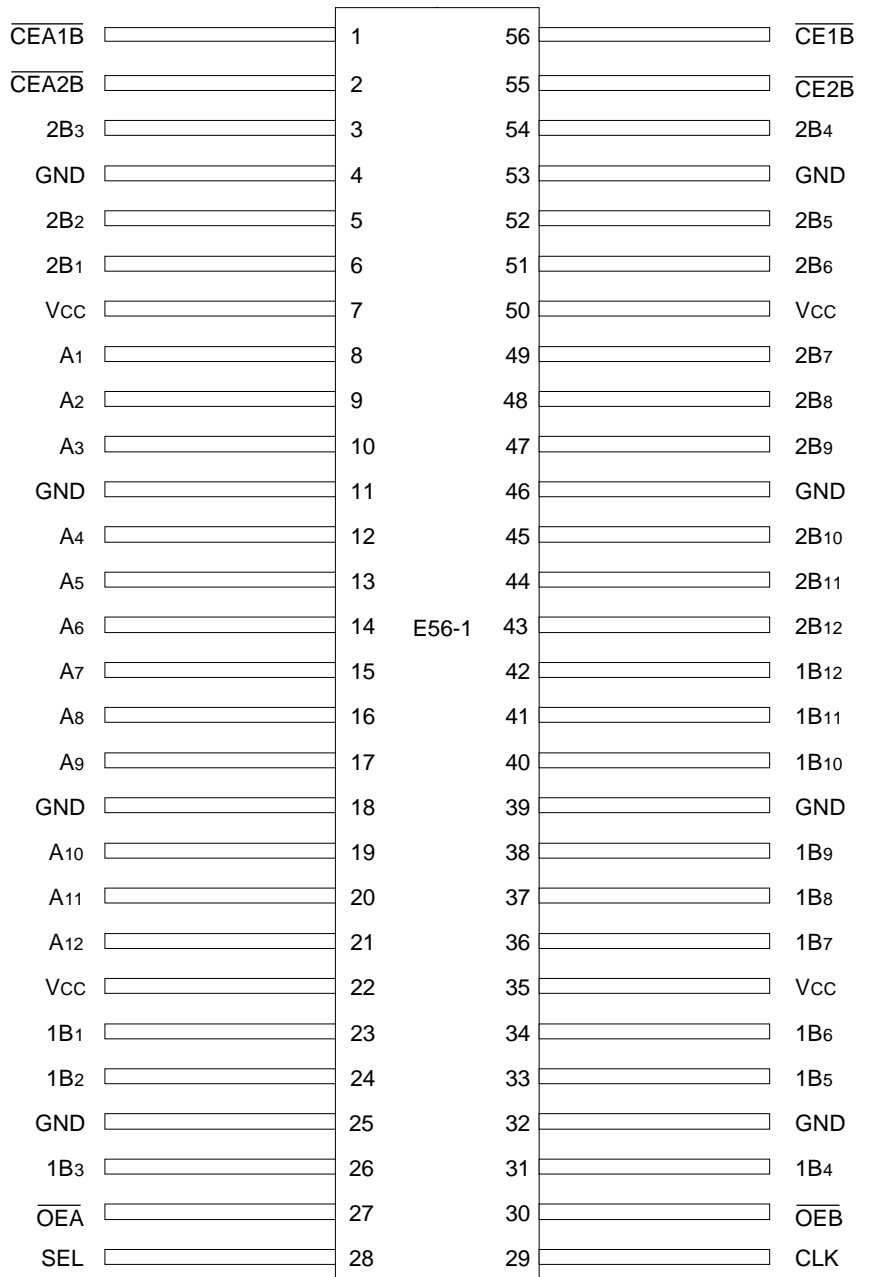

**CERPACK
 TOP VIEW**

3071 drw 03

PIN DESCRIPTION

Signal	I/O	Description
A(1:12)	I/O	Bidirectional Data Port A. Usually connected to the CPU's Address/Data bus. ⁽¹⁾
1B(1:12)	I/O	Bidirectional Data Port 1B. Usually connected to the even path or even bank of memory. ⁽¹⁾
2B(1:12)	I/O	Bidirectional Data Port 2B. Usually connected to the odd path or odd bank of memory. ⁽¹⁾
CLK	I	Clock Input.
$\overline{\text{CEA1B}}$	I	Clock Enable Input for the A-1B Register. If $\overline{\text{CEA1B}}$ is LOW during the rising edge of CLK, data will be clocked into register A-1B (Active LOW).
$\overline{\text{CEA2B}}$	I	Clock Enable Input for the A-2B Register. If $\overline{\text{CEA2B}}$ is LOW during the rising edge of CLK, data will be clocked into register A-2B (Active LOW).
$\overline{\text{CE1B}}$	I	Clock Enable Input for the 1B-A Register. If $\overline{\text{CE1B}}$ is LOW during the rising edge of CLK, data will be clocked into register 1B-A (Active LOW).
$\overline{\text{CE2B}}$	I	Clock Enable Input for the 2B-A Register. If $\overline{\text{CE2B}}$ is LOW during the rising edge of CLK, data will be clocked into register 2B-A (Active LOW).
SEL	I	1B or 2B Path Selection. When HIGH during the rising edge of CLK, SEL enables data transfer from 1B Port to A Port. When LOW during the rising edge of CLK, SEL enables data transfer from 2B Port to A Port.
$\overline{\text{OE}}_A$	I	Synchronous Output Enable for A Port (Active LOW).
$\overline{\text{OEB}}$	I	Synchronous Output Enable for 1B Port and 2B Port (Active LOW).

NOTES:

- On FCT162H272T these pins have "Bus Hold". All other pins are standard inputs, outputs or I/Os.

3071 tbi 01

ABSOLUTE MAXIMUM RATINGS⁽¹⁾

Symbol	Description	Max.	Unit
$V_{\text{TERM}}^{(2)}$	Terminal Voltage with Respect to GND	-0.5 to +7.0	V
$V_{\text{TERM}}^{(3)}$	Terminal Voltage with Respect to GND	-0.5 to $V_{\text{CC}} + 0.5$	V
TSTG	Storage Temperature	-65 to +150	°C
I_{OUT}	DC Output Current	-60 to +120	mA

NOTES:

- Stresses greater than those listed under ABSOLUTE MAXIMUM RATINGS may cause permanent damage to the device. This is a stress rating only and functional operation of the device at these or any other conditions above those indicated in the operational sections of this specification is not implied. Exposure to absolute maximum rating conditions for extended periods may affect reliability.
- All device terminals except FCT162XXXT Output and I/O terminals.
- Output and I/O terminals for FCT162XXXT.

3071 tbi 02

CAPACITANCE ($T_A = +25^\circ\text{C}$, $F = 1.0\text{MHz}$)

Symbol	Parameter ⁽¹⁾	Conditions	Typ.	Max.	Unit
C_{IN}	Input Capacitance	$V_{\text{IN}} = 0\text{V}$	3.5	6.0	pF
$C_{\text{I/O}}$	I/O Capacitance	$V_{\text{OUT}} = 0\text{V}$	3.5	8.0	pF

NOTE:

- This parameter is measured at characterization but not tested.

3071 tbi 03

FUNCTION TABLES⁽²⁾

Inputs							Output
1B	2B	SEL	$\overline{\text{CE1B}}$	$\overline{\text{CE2B}}$	$\overline{\text{OE}}_A$	CLK	A
H	X	H	L	X	L	↑	H
L	X	H	L	X	L	↑	L
X	X	H	H	X	L	↑	A ⁽¹⁾
X	H	L	X	L	L	↑	H
X	L	L	X	L	L	↑	L
X	X	L	X	H	L	↑	A ⁽¹⁾
X	X	X	X	X	H	↑	Z

3071 tbi 04

Inputs					Outputs	
A	$\overline{\text{CEA1B}}$	$\overline{\text{CEA2B}}$	$\overline{\text{OEB}}$	CLK	1B	2B
H	L	L	L	↑	H	H
L	L	L	L	↑	L	L
H	L	H	L	↑	H	B ⁽¹⁾
L	L	H	L	↑	L	B ⁽¹⁾
H	H	L	L	↑	B ⁽¹⁾	H
L	H	L	L	↑	B ⁽¹⁾	L
X	H	H	L	↑	B ⁽¹⁾	B ⁽¹⁾
X	X	X	H	↑	Z	Z
X	X	X	L	↑	Active	Active

NOTES:

- Output level before the indicated steady-state input conditions were established.
- H = HIGH Voltage Level
L = LOW Voltage Level
X = Don't Care
Z = High Impedance
↑ = LOW-to-HIGH Transition

3071 tbi 05

DC ELECTRICAL CHARACTERISTICS OVER OPERATING RANGE (BUS HOLD)

Following Conditions Apply Unless Otherwise Specified:

Commercial: $T_A = -40^{\circ}\text{C}$ to $+85^{\circ}\text{C}$, $V_{CC} = 5.0\text{V} \pm 10\%$; Military: $T_A = -55^{\circ}\text{C}$ to $+125^{\circ}\text{C}$, $V_{CC} = 5.0\text{V} \pm 10\%$

Symbol	Parameter		Test Conditions ⁽¹⁾		Min.	Typ. ⁽²⁾	Max.	Unit
V_{IH}	Input HIGH Level		Guaranteed Logic HIGH Level		2.0	—	—	V
V_{IL}	Input LOW Level		Guaranteed Logic LOW Level		—	—	0.8	V
I_{IH}	Input HIGH Current ⁽⁴⁾	Standard Input ⁽⁵⁾	$V_{CC} = \text{Max.}$	$V_I = V_{CC}$	—	—	± 1	μA
		Standard I/O ⁽⁵⁾			—	—	± 1	
		Bus-Hold Input			—	—	± 100	
		Bus-Hold I/O			—	—	± 100	
I_{IL}	Input LOW Current ⁽⁴⁾	Standard Input ⁽⁵⁾	$V_{CC} = \text{Max.}$	$V_I = \text{GND}$	—	—	± 1	μA
		Standard I/O ⁽⁵⁾			—	—	± 1	
		Bus-Hold Input			—	—	± 100	
		Bus-Hold I/O			—	—	± 100	
I_{BHH} I_{BHL}	Bus Hold Sustain Current ⁽⁴⁾	Bus-Hold Input	$V_{CC} = \text{Min.}$	$V_I = 2.0\text{V}$	-50	—	—	μA
				$V_I = 0.8\text{V}$	+50	—	—	
I_{OZH} I_{OZL}	High Impedance Output Current (3-State Output pins) ^(5,6)		$V_{CC} = \text{Max.}$	$V_O = 2.7\text{V}$	—	—	± 1	μA
				$V_O = 0.5\text{V}$	—	—	± 1	
V_{IK}	Clamp Diode Voltage		$V_{CC} = \text{Min.}, I_{IN} = -18\text{mA}$		—	-0.7	-1.2	V
I_{OS}	Short Circuit Current		$V_{CC} = \text{Max.}, V_O = \text{GND}^{(3)}$		-80	-140	-225	mA
V_H	Input Hysteresis		—		—	100	—	mV
I_{CCL} I_{CCH} I_{CCZ}	Quiescent Power Supply Current		$V_{CC} = \text{Max.}, V_{IN} = \text{GND or } V_{CC}$		—	5	500	μA

3071 tbl 06

OUTPUT DRIVE CHARACTERISTICS FOR FCT162H272T

Symbol	Parameter	Test Conditions ⁽¹⁾		Min.	Typ. ⁽²⁾	Max.	Unit
I_{ODL}	Output LOW Current	$V_{CC} = 5\text{V}, V_{IN} = V_{IH} \text{ or } V_{IL}, V_{OUT} = 1.5\text{V}^{(3)}$		60	115	200	mA
I_{ODH}	Output HIGH Current	$V_{CC} = 5\text{V}, V_{IN} = V_{IH} \text{ or } V_{IL}, V_{OUT} = 1.5\text{V}^{(3)}$		-60	-115	-200	mA
V_{OH}	Output HIGH Voltage	$V_{CC} = \text{Min.}$ $V_{IN} = V_{IH} \text{ or } V_{IL}$	$I_{OH} = -16\text{mA MIL.}$ $I_{OH} = -24\text{mA COM'L.}$	2.4	3.3	—	V
V_{OL}	Output LOW Voltage	$V_{CC} = \text{Min.}$ $V_{IN} = V_{IH} \text{ or } V_{IL}$	$I_{OL} = 16\text{mA MIL.}$ $I_{OL} = 24\text{mA COM'L.}$	—	0.3	0.55	V

3071 Ink 08

NOTES:

- For conditions shown as Max. or Min., use appropriate value specified under Electrical Characteristics for the applicable device type.
- Typical values are at $V_{CC} = 5.0\text{V}$, $+25^{\circ}\text{C}$ ambient.
- Not more than one output should be tested at one time. Duration of the test should not exceed one second.
- Pins with Bus Hold are identified in the pin description.
- The test limit for this parameter is $\pm 5\mu\text{A}$ at $T_A = -55^{\circ}\text{C}$.
- Does not include Bus Hold I/O pins.

POWER SUPPLY CHARACTERISTICS

Symbol	Parameter	Test Conditions ⁽¹⁾	Min.	Typ. ⁽²⁾	Max.	Unit	
ΔI_{CC}	Quiescent Power Supply Current TTL Inputs HIGH	$V_{CC} = \text{Max.}$ $V_{IN} = 3.4V^{(3)}$	—	0.5	1.5	mA	
I_{CCD}	Dynamic Power Supply Current ⁽⁴⁾	$V_{CC} = \text{Max.}$ Outputs Open One Output Port Enabled $\overline{CE}_{xx} = \text{GND}$ One Input Bit Toggling One Output Bit Toggling 50% Duty Cycle	$V_{IN} = V_{CC}$ $V_{IN} = \text{GND}$	—	60	100 $\mu A/$ MHz	
I_C	Total Power Supply Current ⁽⁶⁾	$V_{CC} = \text{Max.}$ Outputs Open $f_i = 10\text{MHz}$ 50% Duty Cycle	$V_{IN} = V_{CC}$ $V_{IN} = \text{GND}$	—	0.6	1.5	mA
		One Output Port Enabled $\overline{CE}_{xx} = \text{GND}$ One Input Bit Toggling One Output Bit Toggling	$V_{IN} = 3.4V$ $V_{IN} = \text{GND}$	—	0.9	2.3	
		$V_{CC} = \text{Max.}$ Outputs Open $f_i = 2.5\text{MHz}$ 50% Duty Cycle	$V_{IN} = V_{CC}$ $V_{IN} = \text{GND}$	—	1.8	3.5 ⁽⁵⁾	
		One Output Port Enabled $\overline{CE}_{xx} = \text{GND}$ Twelve Input Bits Toggling Twelve Output Bits Toggling	$V_{IN} = 3.4V$ $V_{IN} = \text{GND}$	—	4.8	12.5 ⁽⁵⁾	

NOTES:

- For conditions shown as Max. or Min., use appropriate value specified under Electrical Characteristics for the applicable device type.
- Typical values are at $V_{CC} = 5.0V$, $+25^\circ\text{C}$ ambient.
- Per TTL driven input ($V_{IN} = 3.4V$). All other inputs at V_{CC} or GND .
- This parameter is not directly testable, but is derived for use in Total Power Supply Calculations.
- Values for these conditions are examples of the I_{CC} formula. These limits are guaranteed but not tested.
- $I_C = I_{\text{QUIESCENT}} + I_{\text{INPUTS}} + I_{\text{DYNAMIC}}$
 $I_C = I_{CC} + \Delta I_{CC} D_{HNT} + I_{CCD} (f_{CP} N_{CP}/2 + f_i N_i)$
 $I_{CC} = \text{Quiescent Current } (I_{CCL}, I_{CCH} \text{ and } I_{CCZ})$
 $\Delta I_{CC} = \text{Power Supply Current for a TTL High Input } (V_{IN} = 3.4V)$
 $D_H = \text{Duty Cycle for TTL Inputs High}$
 $N_T = \text{Number of TTL Inputs at } D_H$
 $I_{CCD} = \text{Dynamic Current Caused by an Input Transition Pair (HLH or LHL)}$
 $f_{CP} = \text{Clock Frequency for Register Devices (Zero for Non-Register Devices)}$
 $N_{CP} = \text{Number of Clock Inputs at } f_{CP}$
 $f_i = \text{Input Frequency}$
 $N_i = \text{Number of Inputs at } f_i$

3071 tbl 09

SWITCHING CHARACTERISTICS OVER OPERATING RANGE

Symbol	Parameter	Condition ⁽¹⁾	FCT162H272AT				FCT162H272CT				FCT162H272ET				Unit	
			Com'l.		Mil.		Com'l.		Mil.		Com'l.		Mil.			
			Min. ⁽²⁾	Max.	Min. ⁽²⁾	Max.	Min. ⁽²⁾	Max.	Min. ⁽²⁾	Max.	Min. ⁽²⁾	Max.	Min. ⁽²⁾	Max.		
tPLH tPHL	Propagation Delay CLK to 1Bx or CLK to 2Bx	CL = 50pF RL = 500Ω	1.5	5.8	1.5	6.2	1.5	5.2	1.5	5.6	1.5	4.8	—	—	ns	
tPLH tPHL	Propagation Delay CLK to Ax		SEL Stable CExB Enabled	1.5	6.0	1.5	6.4	1.5	5.4	1.5	5.8	1.5	5.0	—	—	ns
			SEL Changing CExB Disabled	1.5	6.0	1.5	6.4	1.5	5.4	1.5	5.8	1.5	5.4	—	—	ns
			SEL Changing CExB Enabled	1.5	7.6	1.5	7.9	1.5	6.6	1.5	7.0	1.5	5.6	—	—	ns
tPZH tPZL	Output Enable Time CLK to Ax, CLK to 1Bx, or CLK to 2Bx			1.5	7.7	1.5	8.1	1.5	6.8	1.5	7.2	1.5	6.0	—	—	ns
tPHZ tPLZ	Output Disable Time CLK to Ax, CLK to 1Bx, or CLK to 2Bx			1.5	6.4	1.5	6.8	1.5	6.0	1.5	6.4	1.5	5.6	—	—	ns
tsu	Set-Up Time, HIGH or LOW Data to CLK			2.0	—	2.0	—	2.0	—	2.0	—	2.0	—	—	—	ns
tsu	Set-Up Time, OE \bar{A} to CLK, OE \bar{B} to CLK			2.0	—	2.0	—	2.0	—	2.0	—	2.0	—	—	—	ns
tsu	Set-Up Time, SEL to CLK			2.0	—	2.0	—	2.0	—	2.0	—	2.0	—	—	—	ns
tsu	Set-Up Time, CE $\bar{A}1\bar{B}$ to CLK, CE $\bar{1}\bar{B}$ to CLK, CE $\bar{2}\bar{B}$ to CLK, or CE $\bar{A}2\bar{B}$ to CLK			2.0	—	2.0	—	2.0	—	2.0	—	2.0	—	—	—	ns
th	Hold Time, CLK to Data			0	—	0	—	0	—	0	—	0	—	—	—	ns
th	Hold Time, CLK to OE \bar{A} , CLK to OE \bar{B} , CLK to SEL			0.5	—	0.5	—	0.5	—	0.5	—	0.5	—	—	—	ns
th	Hold Time, CLK to CE $\bar{A}1\bar{B}$, CLK to CE $\bar{1}\bar{B}$, CLK to CE $\bar{2}\bar{B}$, CLK to CE $\bar{A}2\bar{B}$			0	—	0	—	0	—	0	—	0	—	—	—	ns
tw	Pulse Width, CLK HIGH ⁽⁴⁾		3.0	—	3.0	—	3.0	—	3.0	—	3.0	—	—	—	ns	
tsk(o)	Output Skew ⁽³⁾		—	0.5	—	0.5	—	0.5	—	0.5	—	0.5	—	—	ns	

NOTES:

1. See test circuits and waveforms.
2. Minimum limits are guaranteed but not tested on Propagation Delays.
3. Skew between any two outputs of the same package switching in the same direction. This parameter is guaranteed by design.
4. This parameter is guaranteed but not tested.

3071 tbl 10

TEST CIRCUITS AND WAVEFORMS

TEST CIRCUITS FOR ALL OUTPUTS

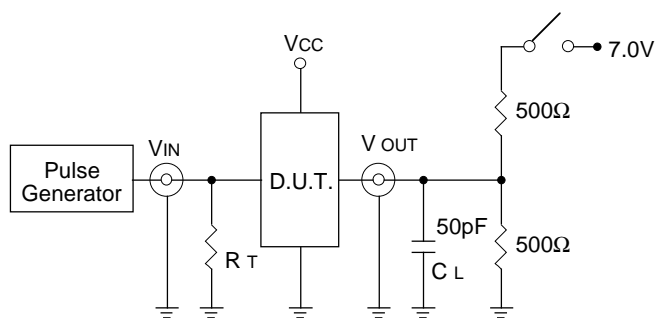

3071 Ink 04

SWITCH POSITION

Test	Switch
Open Drain Disable Low Enable Low	Closed
All Other Tests	Open

DEFINITIONS:

C_L = Load capacitance: includes jig and probe capacitance.

R_T = Termination resistance: should be equal to Z_{OUT} of the Pulse Generator.

3032 tbl 11

SET-UP, HOLD AND RELEASE TIMES

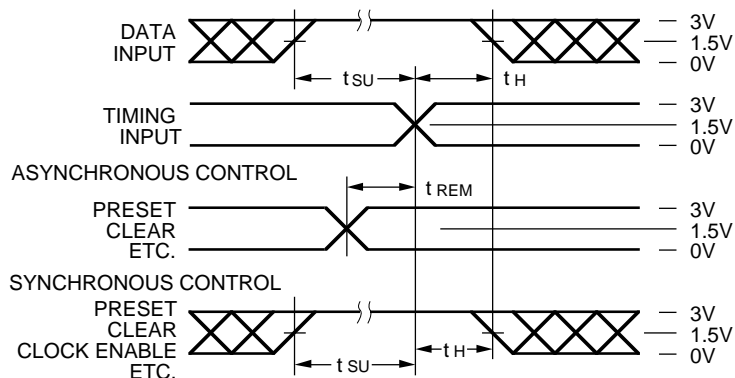

3071 Ink 05

PULSE WIDTH

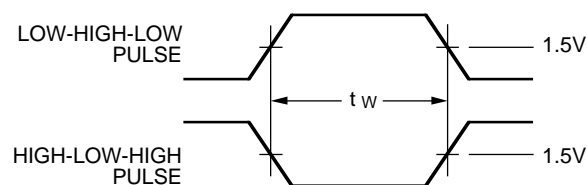

3071 Ink 06

PROPAGATION DELAY

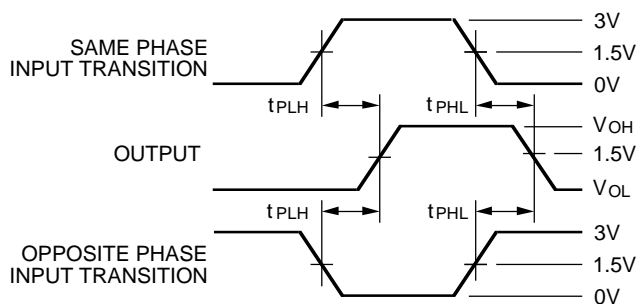

3071 Ink 07

ENABLE AND DISABLE TIMES

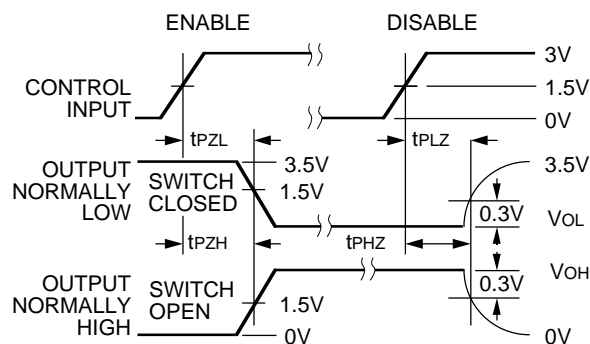

3071 drw 08

NOTES:

- Diagram shown for input Control Enable-LOW and input Control Disable-HIGH
- Pulse Generator for All Pulses: Rate $\leq 1.0\text{MHz}$; $t_r \leq 2.5\text{ns}$; $t_f \leq 2.5\text{ns}$

ORDERING INFORMATION

IDT	XX	FCT	X	X	XXXX	X	X		
Temp. Range		Drive	Bus Hold	Device Type	Package	Process			
								Blank B	Commercial MIL-STD-883, Class B
								PV PA PF E	Shrink Small Outline Package (SO56-1) Thin Shrink Small Outline Package (SO56-2) Thin Very Small Outline Package (SO56-3) CERPACK (E56-1)
								272AT 272CT 272ET	12-Bit Synchronous Tri-Port Bus Exchanger
								H	Bus Hold
								162	16-Bit Balanced Drive
								54 74	-55°C to +125°C -40°C to +85°C

3071 drw 09