



Integrated Device Technology, Inc.

HIGH-SPEED 8K x 9 DUAL-PORT STATIC RAM

IDT7015S/L

FEATURES:

- True Dual-Ported memory cells which allow simultaneous access of the same memory location
- High-speed access
 - Military: 20/25/35ns (max.)
 - Commercial: 12/15/17/20/25/35ns (max.)
- Low-power operation
 - IDT7015S
 - Active: 750mW (typ.)
 - Standby: 5mW (typ.)
 - IDT7015L
 - Active: 750mW (typ.)
 - Standby: 1mW (typ.)
- IDT7015 easily expands data bus width to 18 bits or more using the Master/Slave select when cascading more than one device
- $\overline{M/\overline{S}}$ = H for \overline{BUSY} output flag on Master
 $\overline{M/\overline{S}}$ = L for \overline{BUSY} input on Slave

- Interrupt and Busy Flags
- On-chip port arbitration logic
- Full on-chip hardware support of semaphore signaling between ports
- Fully asynchronous operation from either port
- Devices are capable of withstanding greater than 2001V electrostatic discharge
- TTL-compatible, single 5V ($\pm 10\%$) power supply
- Available in ceramic 68-pin PGA, 68-pin PLCC, and an 80-pin TQFP
- Industrial temperature range (-40°C to $+85^{\circ}\text{C}$) is available, tested to military electrical specifications

DESCRIPTION:

The IDT7015 is a high-speed 8K x 9 Dual-Port Static RAMs. The IDT7015 is designed to be used as stand-alone Dual-Port RAM or as a combination MASTER/SLAVE Dual-Port RAM for 18-bit-or-more word systems. Using the IDT

FUNCTIONAL BLOCK DIAGRAM

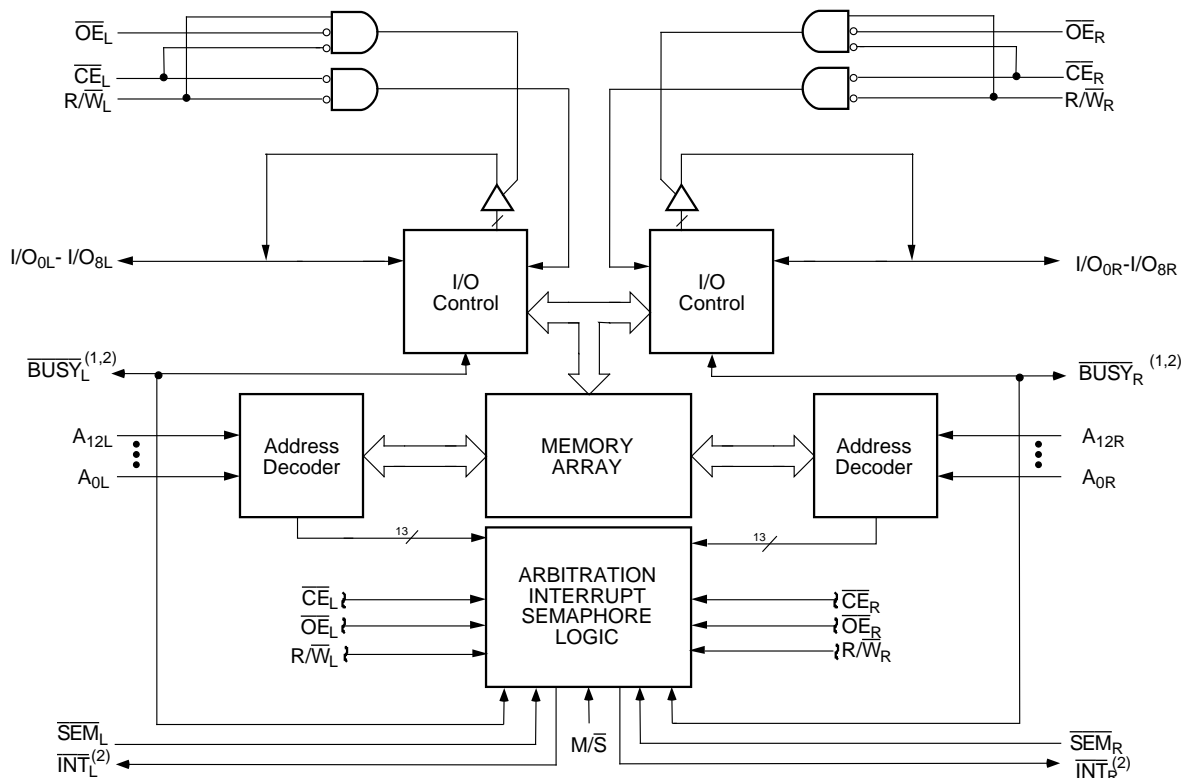

2954 drw 01

NOTES:

1. In MASTER mode: \overline{BUSY} is an output and is a push-pull driver
In SLAVE mode: \overline{BUSY} is input.
2. \overline{BUSY} outputs and \overline{INT} outputs are non-tri-stated push-pull drivers.

The IDT logo is a registered trademark of Integrated Device Technology, Inc.

MILITARY AND COMMERCIAL TEMPERATURE RANGES

OCTOBER 1996

MASTER/SLAVE Dual-Port RAM approach in 18-bit or wider memory system applications results in full-speed, error-free operation without the need for additional discrete logic.

This device provides two independent ports with separate control, address, and I/O pins that permit independent, asynchronous access for reads or writes to any location in memory. An automatic power down feature controlled by \overline{CE} permits the on-chip circuitry of each port to enter a very low standby power mode.

Fabricated using IDT's CMOS high-performance technology, these devices typically operate on only 750mW of power.

The IDT7015 is packaged in a ceramic 68-pin PGA, a 64-pin PLCC and an 80-pin TQFP (Thin Quad FlatPack). Military grade product is manufactured in compliance with the latest revision of MIL-STD-883, Class B, making it ideally suited to military temperature applications demanding the highest level of performance and reliability.

PIN CONFIGURATIONS ^(1,2)

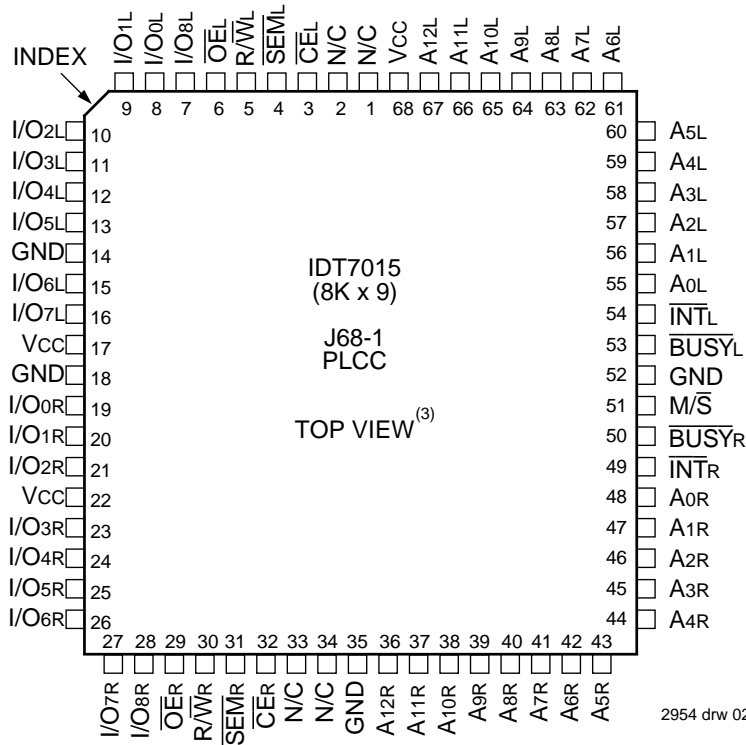

NOTES:

1. All Vcc pins must be connected to power supply.
2. All GND pins must be connected to ground supply.
3. This text does not imply orientation of Part-Mark.

PIN NAMES

Left Port	Right Port	Names
\overline{CE}_L	\overline{CE}_R	Chip Enable
R/ \overline{WL}	R/ \overline{WR}	Read/Write Enable
\overline{OE}_L	\overline{OE}_R	Output Enable
A0L – A12L	A0R – A12R	Address
I/O0L – I/O8L	I/O0R – I/O8R	Data Input/Output
SEML	SEMR	Semaphore Enable
\overline{INT}_L	\overline{INT}_R	Interrupt Flag
\overline{BUSY}_L	\overline{BUSY}_R	Busy Flag
M/S		Master or Slave Select
Vcc		Power
GND		Ground

2954 tbl 01

PIN CONFIGURATIONS (CON'T.) (1,2)

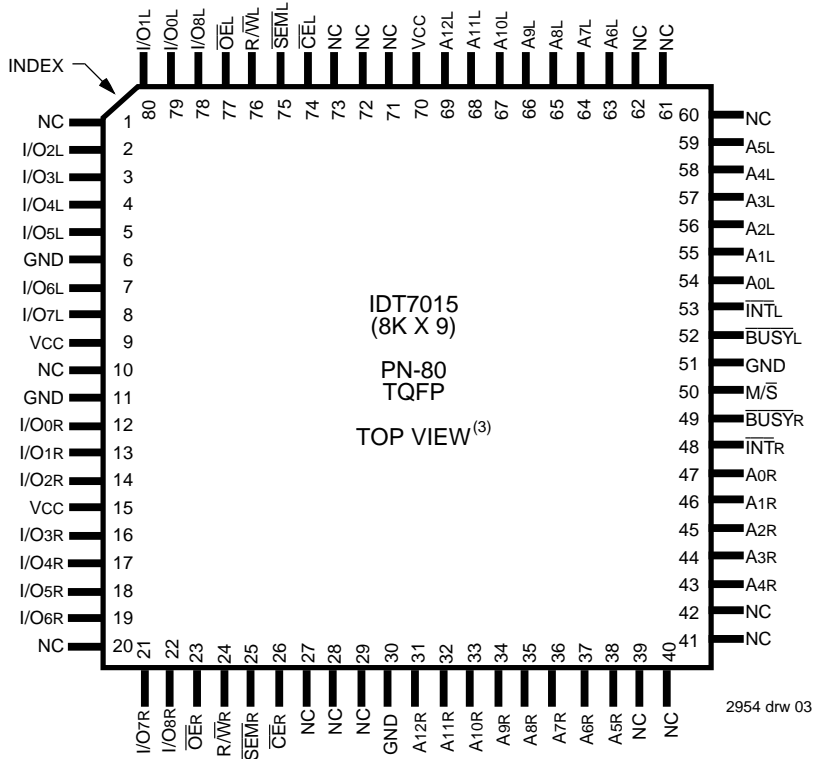

2954 drw 03

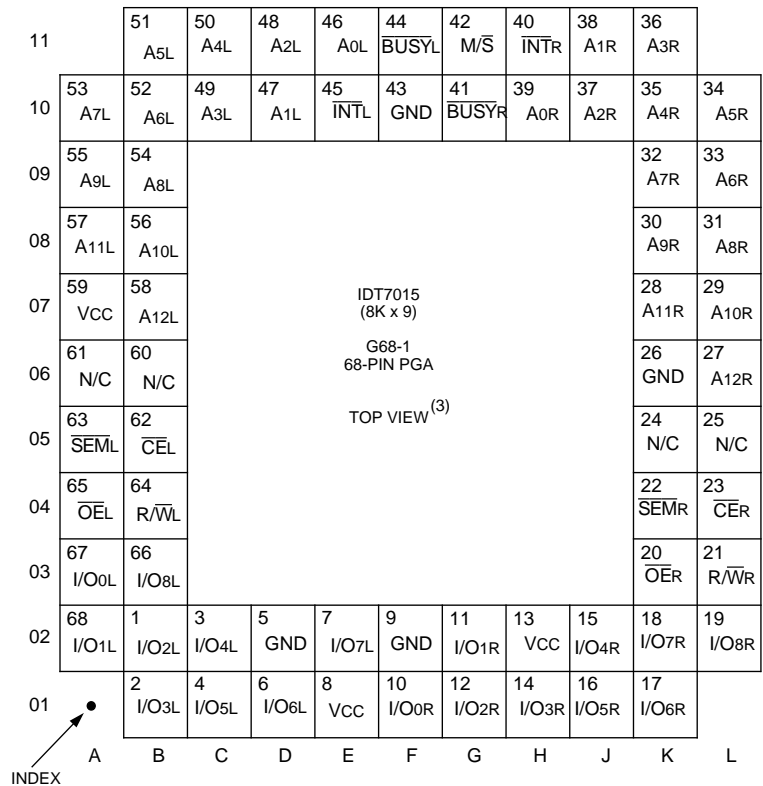

2954 drw 04

NOTES:

1. All Vcc must be connected to power supply.
2. All GND must be connected to ground supply.
3. This text does not imply orientation of Part-Mark.

TRUTH TABLE: NON-CONTENTION READ/WRITE CONTROL

Inputs ⁽¹⁾				Outputs	Mode
\overline{CE}	R/W	\overline{OE}	\overline{SEM}	I/O ₀₋₈	
H	X	X	H	High-Z	Deselected: Power-Down
L	L	X	H	DATAIN	Write to Memory
L	H	L	H	DATAOUT	Read Memory
X	X	H	X	High-Z	Outputs Disabled

NOTE:

1. Condition: A_{0L} — A_{12L} is not equal to A_{0R} — A_{12R}.

2954 tbl 02

TRUTH TABLE: SEMAPHORE READ/WRITE CONTROL⁽¹⁾

Inputs				Outputs	Mode
\overline{CE}	R/W	\overline{OE}	\overline{SEM}	I/O ₀₋₈	
H	H	L	L	DATAOUT	Read Semaphore Flag Data Out (I/O ₀₋₈)
H	✓	X	L	DATAIN	Write I/O ₀ into Semaphore Flag
L	X	X	L	—	Not Allowed

NOTE:

1. There are eight semaphore flags written to via I/O₀ and read from I/O₀₋₈. These eight semaphores are addressed by A₀ - A₇.

2954 tbl 03

ABSOLUTE MAXIMUM RATINGS⁽¹⁾

Symbol	Rating	Commercial	Military	Unit
V _{TERM} ⁽²⁾	Terminal Voltage with Respect to GND	-0.5 to +7.0	-0.5 to +7.0	V
T _A	Operating Temperature	0 to +70	-55 to +125	°C
T _{BIAS}	Temperature Under Bias	-55 to +125	-65 to +135	°C
T _{STG}	Storage Temperature	-55 to +125	-65 to +150	°C
I _{OUT}	DC Output Current	50	50	mA

NOTES:

2954 tbl 04

- Stresses greater than those listed under ABSOLUTE MAXIMUM RATINGS may cause permanent damage to the device. This is a stress rating only and functional operation of the device at these or any other conditions above those indicated in the operational sections of this specification is not implied. Exposure to absolute maximum rating conditions for extended periods may affect reliability.
- V_{TERM} must not exceed V_{CC} + 0.5V for more than 25% of the cycle time or 10ns maximum, and is limited to ≤ 20mA for the period of V_{TERM} ≥ V_{CC} + 0.5V.

RECOMMENDED OPERATING TEMPERATURE AND SUPPLY VOLTAGE

Grade	Ambient Temperature	GND	V _{CC}
Military	-55°C to +125°C	0V	5.0V ± 10%
Commercial	0°C to +70°C	0V	5.0V ± 10%

2954 tbl 05

RECOMMENDED DC OPERATING CONDITIONS

Symbol	Parameter	Min.	Typ.	Max.	Unit
V _{CC}	Supply Voltage	4.5	5.0	5.5	V
GND	Supply Voltage	0	0	0	V
V _{IH}	Input High Voltage	2.2	—	6.0 ⁽²⁾	V
V _{IL}	Input Low Voltage	-0.5 ⁽¹⁾	—	0.8	V

NOTES:

2954 tbl 06

- V_{IL} ≥ -1.5V for pulse width less than 10ns.
- V_{TERM} must not exceed V_{CC} + 0.5V.

CAPACITANCE⁽¹⁾

(T_A = +25°C, f = 1.0MHz) TQFP ONLY

Symbol	Parameter	Conditions ⁽²⁾	Max.	Unit
C _{IN}	Input Capacitance	V _{IN} = 3dV	9	pF
C _{OUT}	Output Capacitance	V _{OUT} = 3dV	10	pF

NOTES:

2954 tbl 07

- This parameter is determined by device characteristics but is not production tested.
- 3dV references the interpolated capacitance when the input and output signals switch from 0V to 3V or from 3V to 0V.

DC ELECTRICAL CHARACTERISTICS OVER THE OPERATING TEMPERATURE AND SUPPLY VOLTAGE RANGE ($V_{CC} = 5.0V \pm 10\%$)

Symbol	Parameter	Test Conditions	7015S		7015L		Unit
			Min.	Max.	Min.	Max.	
I _{LI}	Input Leakage Current ⁽¹⁾	$V_{CC} = 5.5V, V_{IN} = 0V \text{ to } V_{CC}$	—	10	—	5	μA
I _{LO}	Output Leakage Current	$\overline{CE} = V_{IH}, V_{OUT} = 0V \text{ to } V_{CC}$	—	10	—	5	μA
V _{OL}	Output Low Voltage	I _{OL} = 4mA	—	0.4	—	0.4	V
V _{OH}	Output High Voltage	I _{OH} = -4mA	2.4	—	2.4	—	V

NOTE:

1. At $V_{CC} \leq 2.0V$, Input leakages are undefined.

2954 tbl 08

DC ELECTRICAL CHARACTERISTICS OVER THE OPERATING TEMPERATURE AND SUPPLY VOLTAGE RANGE⁽¹⁾ ($V_{CC} = 5.0V \pm 10\%$)

Symbol	Parameter	Test Condition	Version	7015X12 Com'l. Only		7015X15 Com'l. Only		7015X17 Com'l. Only		Unit
				Typ. ⁽²⁾	Max.	Typ. ⁽²⁾	Max.	Typ. ⁽²⁾	Max.	
I _{CC}	Dynamic Operating Current (Both Ports Active)	$\overline{CE} = V_{IL}, \text{Outputs Open}$ $\overline{SEM} = V_{IH}$ $f = f_{MAX}^{(3)}$	MIL. S	—	—	—	—	—	—	mA
			L	—	—	—	—	—	—	
ISB1	Standby Current (Both Ports — TTL Level Inputs)	$\overline{CE}_R = \overline{CE}_L = V_{IH}$ $\overline{SEMR} = \overline{SEML} = V_{IH}$ $f = f_{MAX}^{(3)}$	MIL. S	—	—	—	—	—	—	mA
			L	—	—	—	—	—	—	
ISB2	Standby Current (One Port — TTL Level Inputs)	$\overline{CE}^A = V_{IL} \text{ and } \overline{CE}^B = V_{IH}^{(5)}$ Active Port Outputs Open $f = f_{MAX}^{(3)}$ $\overline{SEMR} = \overline{SEML} = V_{IH}$	MIL. S	—	—	—	—	—	—	mA
			L	—	—	—	—	—	—	
ISB3	Full Standby Current (Both Ports — All CMOS Level Inputs)	Both Ports \overline{CE}_L and $\overline{CE}_R \geq V_{CC} - 0.2V$ $V_{IN} \geq V_{CC} - 0.2V$ or $V_{IN} \leq 0.2V, f = 0^{(4)}$ $\overline{SEMR} = \overline{SEML} \geq V_{CC} - 0.2V$	MIL. S	—	—	—	—	—	—	mA
			L	—	—	—	—	—	—	
ISB4	Full Standby Current (One Port — All CMOS Level Inputs)	$\overline{CE}^A \leq 0.2V$ and $\overline{CE}^B \geq V_{CC} - 0.2V^{(5)}$ $\overline{SEMR} = \overline{SEML} \geq V_{CC} - 0.2V$ $V_{IN} \geq V_{CC} - 0.2V$ or $V_{IN} \leq 0.2V$ Active Port Outputs Open, $f = f_{MAX}^{(3)}$	MIL. S	—	—	—	—	—	—	mA
			L	—	—	—	—	—	—	
			COM'L. S	170	325	170	310	170	310	mA
			L	170	275	170	260	170	260	
			COM'L. S	25	70	25	60	25	60	mA
			L	25	60	25	50	25	50	
			COM'L. S	105	200	105	190	105	190	mA
			L	105	170	105	160	109	160	
			COM'L. S	1.0	15	1.0	15	1.0	15	mA
			L	0.2	5	0.2	5	0.2	5	
			COM'L. S	100	180	100	170	100	170	mA
			L	100	150	100	140	100	140	

NOTES:

- "X" in part numbers indicates power rating (S or L).
- $V_{CC} = 5V, T_A = +25^\circ C$, and are not production tested. I_{CCDC} = 120mA(typ.)
- At $f = f_{MAX}$, address and I/O's are cycling at the maximum frequency read cycle of 1/trc, and using "AC Test Conditions" of input levels of GND to 3V.
- $f = 0$ means no address or control lines change.
- Port "A" may be either left or right port. Port "B" is the opposite of port "A".

2954 tbl 09

DC ELECTRICAL CHARACTERISTICS OVER THE OPERATING TEMPERATURE AND SUPPLY VOLTAGE RANGE⁽¹⁾(Cont'd) ($V_{CC} = 5.0V \pm 10\%$)

Symbol	Parameter	Test Condition	Version	7015X20		7015X25		7015X35		Unit
				Typ. ⁽²⁾	Max.	Typ. ⁽²⁾	Max.	Typ. ⁽²⁾	Max.	
I _{CC}	Dynamic Operating Current (Both Ports Active)	$\overline{CE} = V_{IL}$, Outputs Open $\overline{SEM} = V_{IH}$ $f = f_{MAX}^{(3)}$	MIL. S L	—	—	155	340	150	300	mA
				COM'L. S L	160 160	290 240	155 155	265 220	150 150	
I _{SB1}	Standby Current (Both Ports — TTL Level Inputs)	$\overline{CEL} = \overline{CER} = V_{IH}$ $\overline{SEMR} = \overline{SEML} = V_{IH}$ $f = f_{MAX}^{(3)}$	MIL. S L	—	—	16	80	13	80	mA
				COM'L. S L	20 20	60 50	16 16	60 50	13 13	
I _{SB2}	Standby Current (One Port — TTL Level Inputs)	$\overline{CE}^A = V_{IL}$ and $\overline{CE}^B = V_{IH}^{(5)}$ Active Port Outputs Open $f = f_{MAX}^{(3)}$ $\overline{SEMR} = \overline{SEML} = V_{IH}$	MIL. S L	—	—	90	215	85	190	mA
				COM'L. S L	95 95	180 150	90 90	170 140	85 85	
I _{SB3}	Full Standby Current (Both Ports — All CMOS Level Inputs)	Both Ports \overline{CEL} and $\overline{CER} \geq V_{CC} - 0.2V$ $V_{IN} \geq V_{CC} - 0.2V$ or $V_{IN} \leq 0.2V$, $f = 0^{(4)}$ $\overline{SEMR} = \overline{SEML} \geq V_{CC} - 0.2V$	MIL. S L	—	—	1.0	30	1.0	30	mA
				COM'L. S L	1.0 0.2	15 5	1.0 0.2	15 5	1.0 0.2	
I _{SB4}	Full Standby Current (One Port — All CMOS Level Inputs)	$\overline{CE}^A \leq 0.2V$ and $\overline{CE}^B \geq V_{CC} - 0.2V^{(5)}$ $\overline{SEMR} = \overline{SEML} \geq V_{CC} - 0.2V$ $V_{IN} \geq V_{CC} - 0.2V$ or $V_{IN} \leq 0.2V$ Active Port Outputs Open, $f = f_{MAX}^{(3)}$	MIL. S L	—	—	85	200	80	175	mA
				COM'L. S L	90 90	155 130	85 85	145 120	80 80	

NOTES:

- "X" in part numbers indicates power rating (S or L).
- $V_{CC} = 5V$, $T_A = +25^\circ C$, and are not production tested. $I_{CCDC} = 120mA$ (typ.)
- At $f = f_{MAX}$, address and I/O's are cycling at the maximum frequency read cycle of 1/ t_{RC} , and using "AC Test Conditions" of input levels of GND to 3V.
- $f = 0$ means no address or control lines change.
- Port "A" may be either left or right port. Port "B" is the opposite of port "A".

2954 tbl 10

OUTPUT LOADS AND AC TEST CONDITIONS

Input Pulse Levels	GND to 3.0V
Input Rise/Fall Times ⁽¹⁾	5ns Max.
Input Timing Reference Levels	1.5V
Output Reference Levels	1.5V
Output Load	Figure 1 and 2

NOTE:

- 3ns Max. for $t_{AA}=12ns$

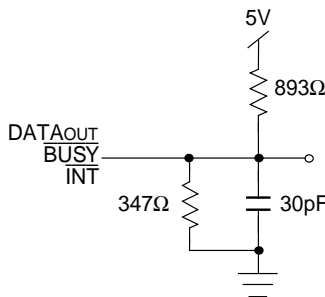

2954 drw 05

Figure 1. AC Output Test Load

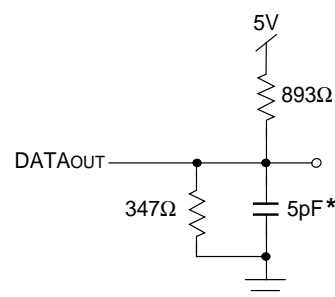

2954 drw 06

Figure 2. Output Test Load (For t_{LZ} , t_{HZ} , t_{WZ} , t_{OW}) Including scope and jig.

AC ELECTRICAL CHARACTERISTICS OVER THE OPERATING TEMPERATURE AND SUPPLY VOLTAGE RANGE⁽⁴⁾

Symbol	Parameter	IDT7015X12 Com'l. Only		IDT7015X15 Com'l. Only		IDT7015X17 Com'l. Only		Unit
		Min.	Max.	Min.	Max.	Min.	Max.	
READ CYCLE								
t _{RC}	Read Cycle Time	12	—	15	—	17	—	ns
t _{AA}	Address Access Time	—	12	—	15	—	17	ns
t _{ACE}	Chip Enable Access Time ⁽³⁾	—	12	—	15	—	17	ns
t _{AOE}	Output Enable Access Time	—	8	—	10	—	10	ns
t _{OH}	Output Hold from Address Change	3	—	3	—	3	—	ns
t _{LZ}	Output Low-Z Time ^(1, 2)	3	—	3	—	3	—	ns
t _{HZ}	Output High-Z Time ^(1, 2)	—	10	—	10	—	10	ns
t _{PU}	Chip Enable to Power Up Time ⁽²⁾	0	—	0	—	0	—	ns
t _{PD}	Chip Disable to Power Down Time ⁽²⁾	—	12	—	15	—	17	ns
t _{SOP}	Semaphore Flag Update Pulse (\overline{OE} or \overline{SEM})	10	—	10	—	10	—	ns
t _{SAA}	Semaphore Address Access Time	—	12	—	15	—	17	ns

Symbol	Parameter	IDT7015X20		IDT7015X25		IDT7015X35		Unit
		Min.	Max.	Min.	Max.	Min.	Max.	
READ CYCLE								
t _{RC}	Read Cycle Time	20	—	25	—	35	—	ns
t _{AA}	Address Access Time	—	20	—	25	—	35	ns
t _{ACE}	Chip Enable Access Time ⁽³⁾	—	20	—	25	—	35	ns
t _{AOE}	Output Enable Access Time	—	12	—	13	—	20	ns
t _{OH}	Output Hold from Address Change	3	—	3	—	3	—	ns
t _{LZ}	Output Low-Z Time ^(1, 2)	3	—	3	—	3	—	ns
t _{HZ}	Output High-Z Time ^(1, 2)	—	12	—	15	—	20	ns
t _{PU}	Chip Enable to Power Up Time ⁽²⁾	0	—	0	—	0	—	ns
t _{PD}	Chip Disable to Power Down Time ⁽²⁾	—	20	—	25	—	35	ns
t _{SOP}	Semaphore Flag Update Pulse (\overline{OE} or \overline{SEM})	10	—	10	—	15	—	ns
t _{SAA}	Semaphore Address Access Time	—	20	—	25	—	35	ns

NOTES:

1. Transition is measured $\pm 200\text{mV}$ from Low- or High-impedance voltage with the Output test load (Figure 2).
2. This parameter is guaranteed by device characterization but not tested.
3. To access RAM, $\overline{CE} = V_{IL}$ and $\overline{SEM} = V_{IH}$. To access semaphore, $\overline{CE} = V_{IH}$ and $\overline{SEM} = V_{IL}$.
4. "X" in part numbers indicates power rating (S or L).

2954 tbl 11

WAVEFORM OF READ CYCLES⁽⁵⁾

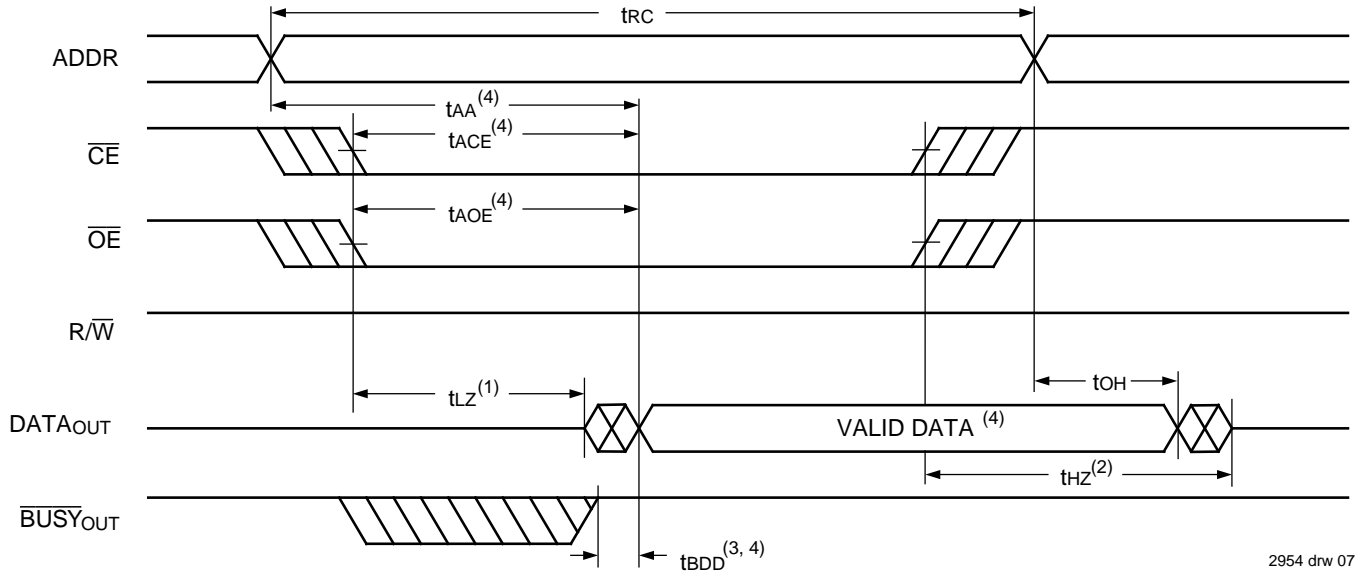

2954 drw 07

NOTES:

1. Timing depends on which signal is asserted last, \overline{OE} or \overline{CE} .
2. Timing depends on which signal is de-asserted first, \overline{CE} or \overline{OE} .
3. t_{BDD} delay is required only in cases where the opposite port is completing a write operation to the same address location. For simultaneous read operations \overline{BUSY} has no relation to valid output data.
4. Start of valid data depends on which timing becomes effective last: t_{AOE} , t_{ACE} , t_{AA} or t_{BDD} .
5. $\overline{SEM} = V_{IH}$.

TIMING OF POWER-UP / POWER-DOWN

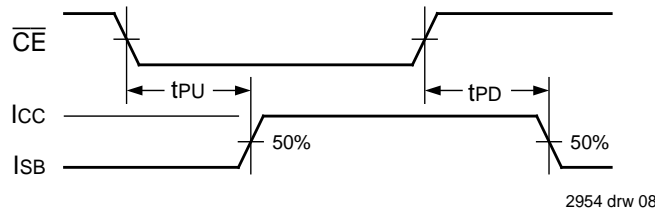

2954 drw 08

AC ELECTRICAL CHARACTERISTICS OVER THE OPERATING TEMPERATURE AND SUPPLY VOLTAGE⁽⁵⁾

Symbol	Parameter	IDT7015X12 Com'l. Only		IDT7015X15 Com'l. Only		IDT7015X17 Com'l. Only		Unit
		Min.	Max.	Min.	Max.	Min.	Max.	
WRITE CYCLE								
tWC	Write Cycle Time	12	—	15	—	17	—	ns
tEW	Chip Enable to End-of-Write ⁽³⁾	10	—	12	—	12	—	ns
tAW	Address Valid to End-of-Write	10	—	12	—	12	—	ns
tAS	Address Set-up Time ⁽³⁾	0	—	0	—	0	—	ns
tWP	Write Pulse Width	10	—	12	—	12	—	ns
tWR	Write Recovery Time	2	—	2	—	2	—	ns
tdW	Data Valid to End-of-Write	10	—	10	—	10	—	ns
thZ	Output High-Z Time ^(1, 2)	—	10	—	10	—	10	ns
tdH	Data Hold Time ⁽⁴⁾	0	—	0	—	0	—	ns
twZ	Write Enable to Output in High-Z ^(1, 2)	—	10	—	10	—	10	ns
tOW	Output Active from End-of-Write ^(1, 2, 4)	3	—	3	—	0	—	ns
tSWRD	$\overline{\text{SEM}}$ Flag Write to Read Time	5	—	5	—	5	—	ns
tSPS	$\overline{\text{SEM}}$ Flag Contention Window	5	—	5	—	5	—	ns

Symbol	Parameter	IDT7015X20		IDT7015X25		IDT7015X35		Unit
		Min.	Max.	Min.	Max.	Min.	Max.	
WRITE CYCLE								
tWC	Write Cycle Time	20	—	25	—	35	—	ns
tEW	Chip Enable to End-of-Write ⁽³⁾	15	—	20	—	30	—	ns
tAW	Address Valid to End-of-Write	15	—	20	—	30	—	ns
tAS	Address Set-up Time ⁽³⁾	0	—	0	—	0	—	ns
tWP	Write Pulse Width	15	—	20	—	25	—	ns
tWR	Write Recovery Time	2	—	2	—	2	—	ns
tdW	Data Valid to End-of-Write	15	—	15	—	15	—	ns
thZ	Output High-Z Time ^(1, 2)	—	12	—	15	—	20	ns
tdH	Data Hold Time ⁽⁴⁾	0	—	0	—	0	—	ns
twZ	Write Enable to Output in High-Z ^(1, 2)	—	12	—	15	—	20	ns
tOW	Output Active from End-of-Write ^(1, 2, 4)	3	—	3	—	3	—	ns
tSWRD	$\overline{\text{SEM}}$ Flag Write to Read Time	5	—	5	—	5	—	ns
tSPS	$\overline{\text{SEM}}$ Flag Contention Window	5	—	5	—	5	—	ns

NOTES:

2954 tbl 12

1. Transition is measured $\pm 200\text{mV}$ from Low or High-impedance voltage with the Output test load (Figure 2).
2. This parameter is guaranteed by device characterization but not tested.
3. To access RAM, $\overline{\text{CE}} = \text{V}_{\text{IL}}$ and $\overline{\text{SEM}} = \text{V}_{\text{IH}}$. To access semaphore, $\overline{\text{CE}} = \text{V}_{\text{IH}}$ and $\overline{\text{SEM}} = \text{V}_{\text{IL}}$. Either condition must be valid for the entire tEW time.
4. The specification for tdH must be met by the device supplying write data to the RAM under all operating conditions. Although tdH and tOW values will vary over voltage and temperature, the actual tdH will always be smaller than the actual tOW.
5. "X" in part numbers indicates power rating (S or L).

TIMING WAVEFORM OF WRITE CYCLE NO. 1, $\overline{R/\overline{W}}$ CONTROLLED TIMING^(1,5,8)

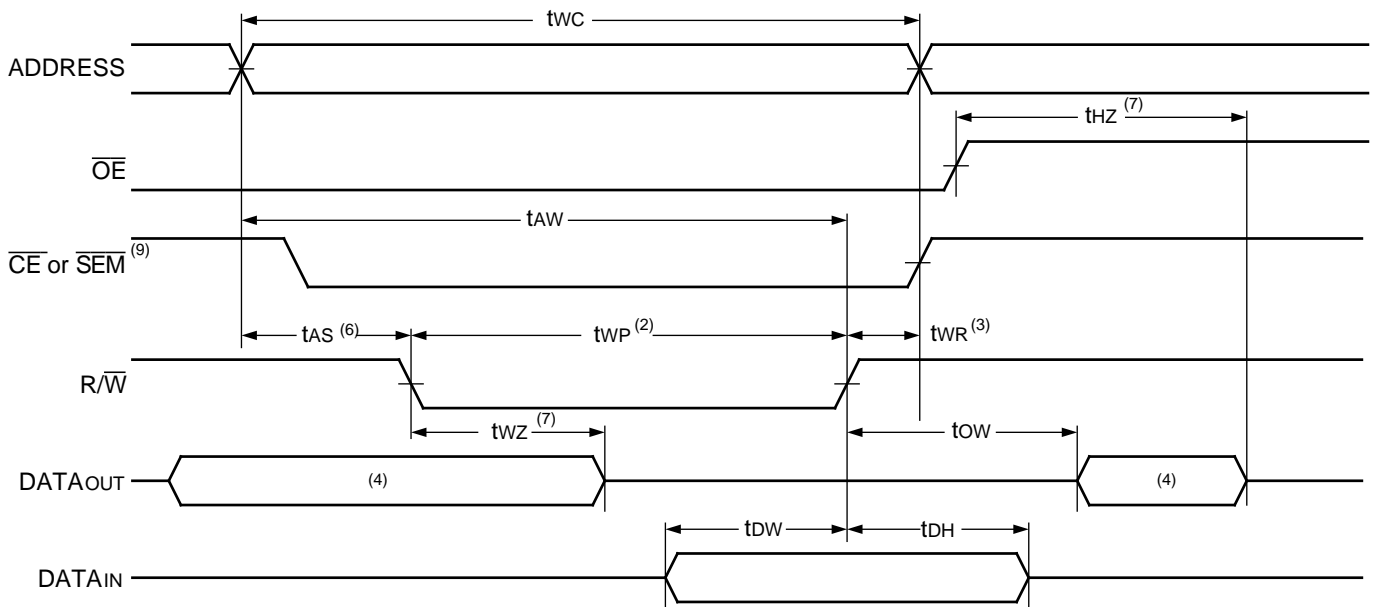

2954 drw 09

TIMING WAVEFORM OF WRITE CYCLE NO. 2, \overline{CE} CONTROLLED TIMING^(1,5)

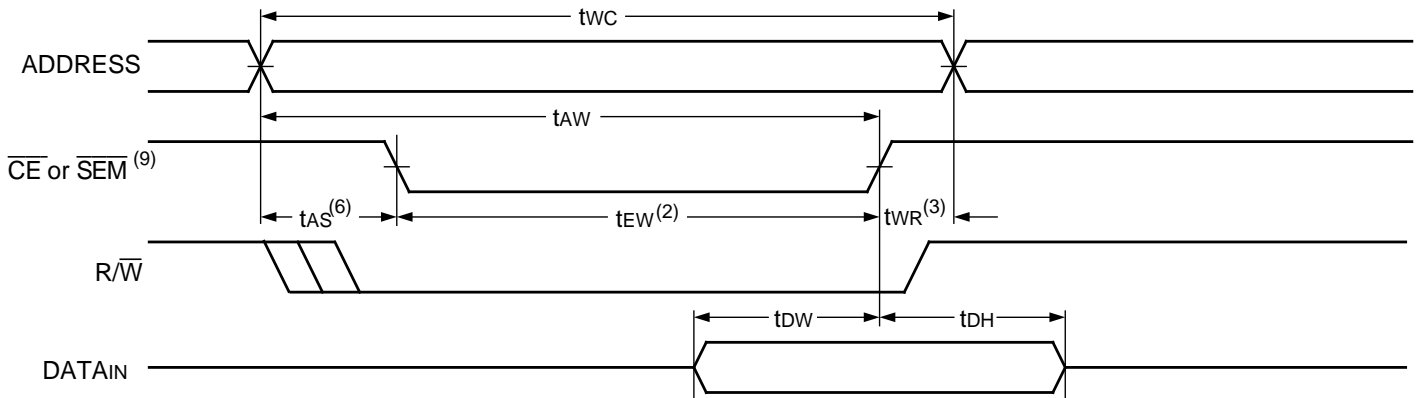

2954 drw 10

NOTES:

1. $\overline{R/\overline{W}}$ or \overline{CE} must be High during all address transitions.
2. A write occurs during the overlap (t_{EW} or t_{WP}) of a Low \overline{CE} and a Low $\overline{R/\overline{W}}$ for memory array writing cycle.
3. t_{WR} is measured from the earlier of \overline{CE} or $\overline{R/\overline{W}}$ (or \overline{SEM} or $\overline{R/\overline{W}}$) going High to the end of write cycle.
4. During this period, the I/O pins are in the output state and input signals must not be applied.
5. If the \overline{CE} or \overline{SEM} Low transition occurs simultaneously with or after the $\overline{R/\overline{W}}$ Low transition, the outputs remain in the High-impedance state.
6. Timing depends on which enable signal is asserted last, \overline{CE} or $\overline{R/\overline{W}}$.
7. This parameter is guaranteed by device characterization but is not production tested, transition is measured +/-200mV from steady state with the Output Test load (Figure 2).
8. If \overline{OE} is Low during $\overline{R/\overline{W}}$ controlled write cycle, the write pulse width must be the larger of t_{WP} or ($t_{WZ} + t_{OW}$) to allow the I/O drivers to turn off and data to be placed on the bus for the required t_{OW} . If \overline{OE} is High during an $\overline{R/\overline{W}}$ controlled write cycle, this requirement does not apply and the write pulse can be as short as the specified t_{WP} .
9. To access RAM, $\overline{CE} = V_{IL}$ and $\overline{SEM} = V_{IH}$. To access Semaphore, $\overline{CE} = V_{IH}$ and $\overline{SEM} = V_{IL}$. t_{EW} must be met for either condition.

TIMING WAVEFORM OF SEMAPHORE READ AFTER WRITE TIMING, EITHER SIDE⁽¹⁾

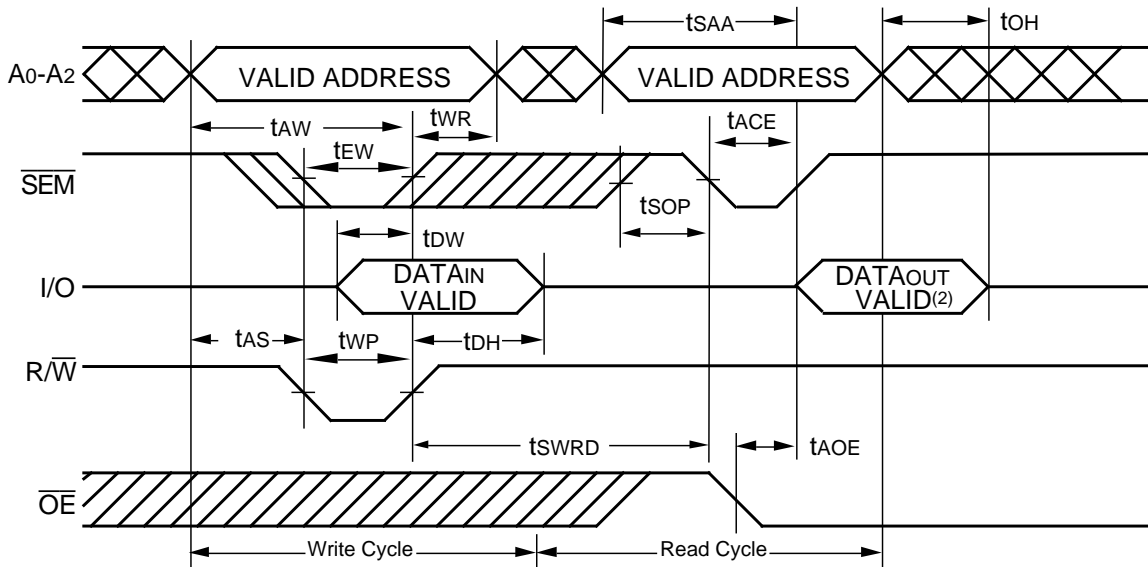

2954 drw 11

NOTES:

1. $\overline{CE} = V_{IH}$ for the duration of the above timing (both write and read cycle).
2. "DATAOUT VALID" represents all I/O's (I/O₀-I/O₈) equal to the semaphore value.

TIMING WAVEFORM OF SEMAPHORE WRITE CONTENTION^(1,3,4)

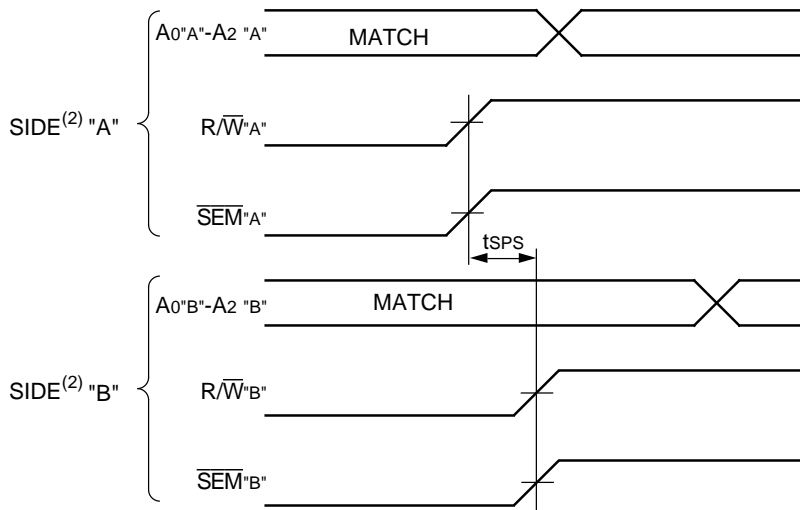

2954 drw 12

NOTES:

1. $DOR = DOL = V_{IH}$, $\overline{CE}_R = \overline{CE}_L = V_{IH}$.
2. All timing is the same for left and right ports. Port "A" may be either left or right port. "B" is the opposite port from "A".
3. This parameter is measured from R/\overline{W}^A or \overline{SEM}^A going high to R/\overline{W}^B or \overline{SEM}^B going High.
4. If tSPS is not satisfied, there is no guarantee which side will obtain the semaphore flag.

AC ELECTRICAL CHARACTERISTICS OVER THE OPERATING TEMPERATURE AND SUPPLY VOLTAGE RANGE⁽⁶⁾

Symbol	Parameter	IDT7015X12 Com'l. Only		IDT7015X15 Com'l. Only		IDT7015X17 Com'l. Only		Unit
		Min.	Max.	Min.	Max.	Min.	Max.	
BUSY TIMING ($M/\bar{S} = V_{IH}$)								
tBAA	\overline{BUSY} Access Time from Address Match	—	12	—	15	—	17	ns
tBDA	\overline{BUSY} Disable Time from Address Not Matched	—	12	—	15	—	17	ns
tBAC	\overline{BUSY} Access Time from Chip Enable Low	—	12	—	15	—	17	ns
tBDC	\overline{BUSY} Disable Time from Chip Enable High	—	12	—	15	—	17	ns
tAPS	Arbitration Priority Set-up Time ⁽²⁾	5	—	5	—	5	—	ns
tBDD	\overline{BUSY} Disable to Valid Data ⁽³⁾	—	15	—	18	—	18	ns
tWH	Write Hold After \overline{BUSY} ⁽⁵⁾	11	—	13	—	13	—	ns
BUSY TIMING ($M/\bar{S} = V_{IL}$)								
tWB	\overline{BUSY} Input to Write ⁽⁴⁾	0	—	0	—	0	—	ns
tWH	Write Hold After \overline{BUSY} ⁽⁵⁾	11	—	13	—	13	—	ns
PORT-TO-PORT DELAY TIMING								
tWDD	Write Pulse to Data Delay ⁽¹⁾	—	25	—	30	—	30	ns
tDDD	Write Data Valid to Read Data Delay ⁽¹⁾	—	20	—	25	—	25	ns

Symbol	Parameter	IDT7015X20		IDT7015X25		IDT7015X35		Unit
		Min.	Max.	Min.	Max.	Min.	Max.	
BUSY TIMING ($M/\bar{S} = V_{IH}$)								
tBAA	\overline{BUSY} Access Time from Address Match	—	20	—	20	—	20	ns
tBDA	\overline{BUSY} Disable Time from Address Not Matched	—	20	—	20	—	20	ns
tBAC	\overline{BUSY} Access Time from Chip Enable Low	—	20	—	20	—	20	ns
tBDC	\overline{BUSY} Disable Time from Chip Enable High	—	17	—	17	—	20	ns
tAPS	Arbitration Priority Set-up Time ⁽²⁾	5	—	5	—	5	—	ns
tBDD	\overline{BUSY} Disable to Valid Data ⁽³⁾	—	30	—	30	—	35	ns
tWH	Write Hold After \overline{BUSY} ⁽⁵⁾	15	—	17	—	25	—	ns
BUSY TIMING ($M/\bar{S} = V_{IL}$)								
tWB	\overline{BUSY} Input to Write ⁽⁴⁾	0	—	0	—	0	—	ns
tWH	Write Hold After \overline{BUSY} ⁽⁵⁾	15	—	17	—	25	—	ns
PORT-TO-PORT DELAY TIMING								
tWDD	Write Pulse to Data Delay ⁽¹⁾	—	45	—	50	—	60	ns
tDDD	Write Data Valid to Read Data Delay ⁽¹⁾	—	30	—	35	—	45	ns

NOTES:

1. Port-to-port delay through RAM cells from writing port to reading port, refer to "Timing Wave form of Write with Port-to-Port Read and $\overline{BUSY} (M/\bar{S} = V_{IH})$ ".
2. To ensure that the earlier of the two ports wins.
3. tBDD is a calculated parameter and is the greater of 0, tWDD – tWP (actual), or tDDD – tDW (actual).
4. To ensure that the write cycle is inhibited on port "B" during contention on port "A".
5. To ensure that a write cycle is completed on port "B" after contention on port "A".
6. "X" in part numbers indicates power rating (S or L).

2940 tbl 13

TIMING WAVEFORM OF READ WITH $\overline{\text{BUSY}}$ ($M/\overline{\text{S}} = V_{IH}$)^(2,4,5)

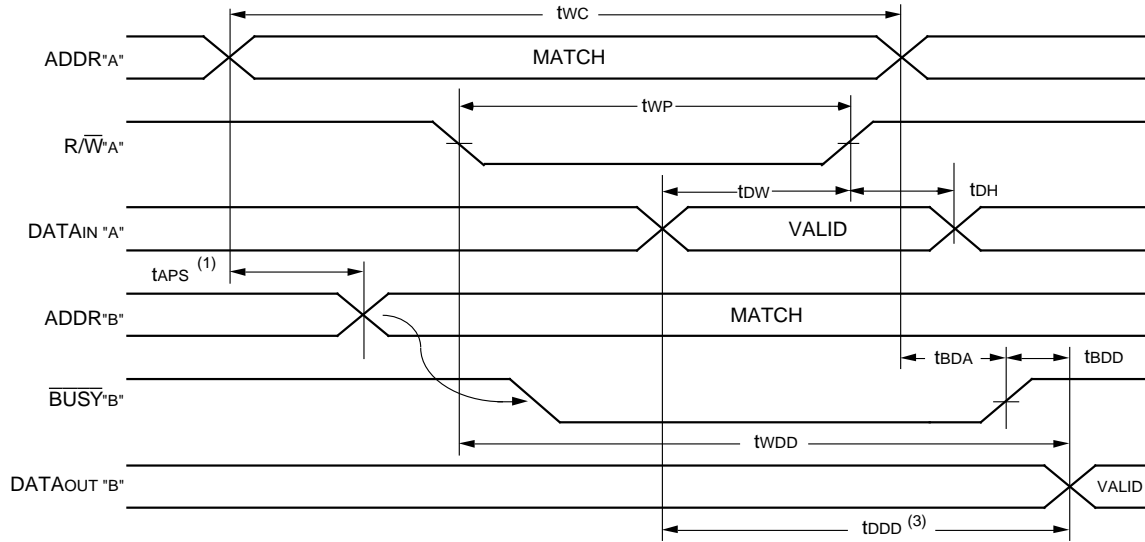

2954 drw 13

NOTES:

1. To ensure that the earlier of the two ports wins. t_{APS} is ignored for $M/\overline{\text{S}}=V_{IL}$.
2. $\overline{\text{CE}}_L = \overline{\text{CE}}_R = V_{IL}$.
3. $\overline{\text{OE}} = V_{IL}$ for the reading port.
4. If $M/\overline{\text{S}} = V_{IL}$ (slave), $\overline{\text{BUSY}}$ is an input. Then for this example $\overline{\text{BUSY}}^A = V_{IH}$ and $\overline{\text{BUSY}}^B$ input is shown above.
5. All timing is the same for left and right ports. Port "A" may be either the left or right port. Port "B" is the port opposite from port "A".

TIMING WAVEFORM OF WRITE WITH $\overline{\text{BUSY}}$

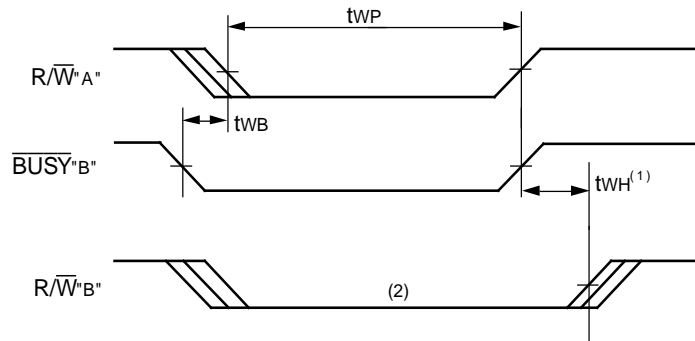

2954 drw 14

NOTES:

1. t_{WH} must be met for both $\overline{\text{BUSY}}$ input (SLAVE) and output (MASTER).
2. $\overline{\text{BUSY}}$ is asserted on port "B" blocking $R/\overline{\text{W}}^B$, until $\overline{\text{BUSY}}^B$ goes High.
3. All timing is the same for left and right ports. Port "A" may be either the left or right port. Port "B" is the port opposite from port "A".

WAVEFORM OF BUSY ARBITRATION CONTROLLED BY \overline{CE} TIMING ($M/\overline{S} = V_{IH}$)⁽¹⁾

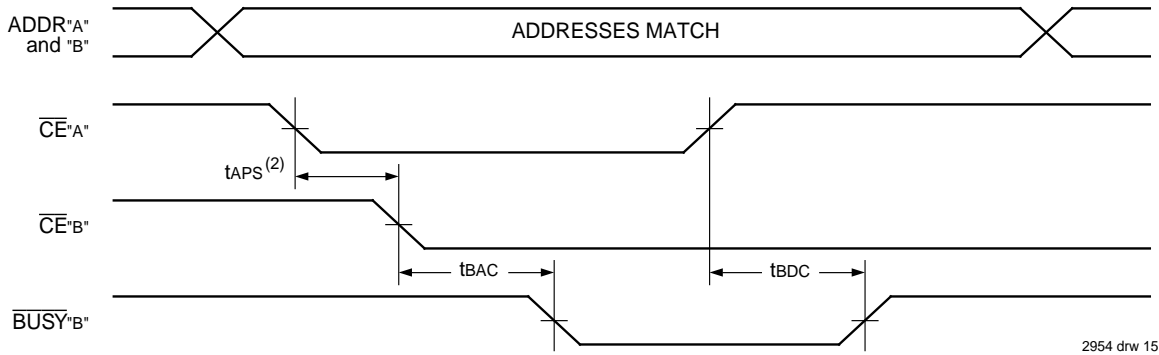

2954 drw 15

WAVEFORM OF BUSY ARBITRATION CYCLE CONTROLLED BY ADDRESS MATCH TIMING ($M/\overline{S} = V_{IH}$)⁽¹⁾

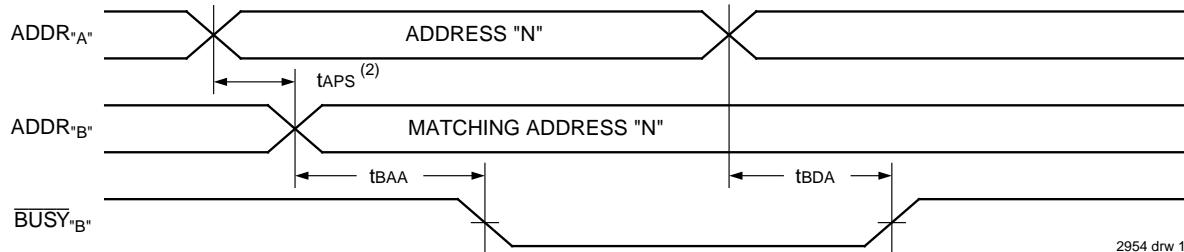

2954 drw 16

NOTES:

1. All timing is the same for left and right ports. Port "A" may be either the left or right port. Port "B" is the port opposite from "A".
2. If tAPS is not satisfied, the busy signal will be asserted on one side or another but there is no guarantee on which side busy will be asserted.

AC ELECTRICAL CHARACTERISTICS OVER THE OPERATING TEMPERATURE AND SUPPLY VOLTAGE RANGE⁽¹⁾

Symbol	Parameter	IDT7015X12 Com'l. Only		IDT7015X15 Com'l. Only		IDT7015X17 Com'l. Only		Unit
		Min.	Max.	Min.	Max.	Min.	Max.	
INTERRUPT TIMING								
tAS	Address Set-up Time	0	—	0	—	0	—	ns
tWR	Write Recovery Time	0	—	0	—	0	—	ns
tINS	Interrupt Set Time	—	12	—	15	—	17	ns
tINR	Interrupt Reset Time	—	12	—	15	—	17	ns

Symbol	Parameter	IDT7015X20		IDT7015X25		IDT7015X35		Unit
		Min.	Max.	Min.	Max.	Min.	Max.	
INTERRUPT TIMING								
tAS	Address Set-up Time	0	—	0	—	0	—	ns
tWR	Write Recovery Time	0	—	0	—	0	—	ns
tINS	Interrupt Set Time	—	20	—	20	—	25	ns
tINR	Interrupt Reset Time	—	20	—	20	—	25	ns

NOTE:

1. "X" in part numbers indicates power rating (S or L).

2739 tbl 14

WAVEFORM OF INTERRUPT TIMING⁽¹⁾

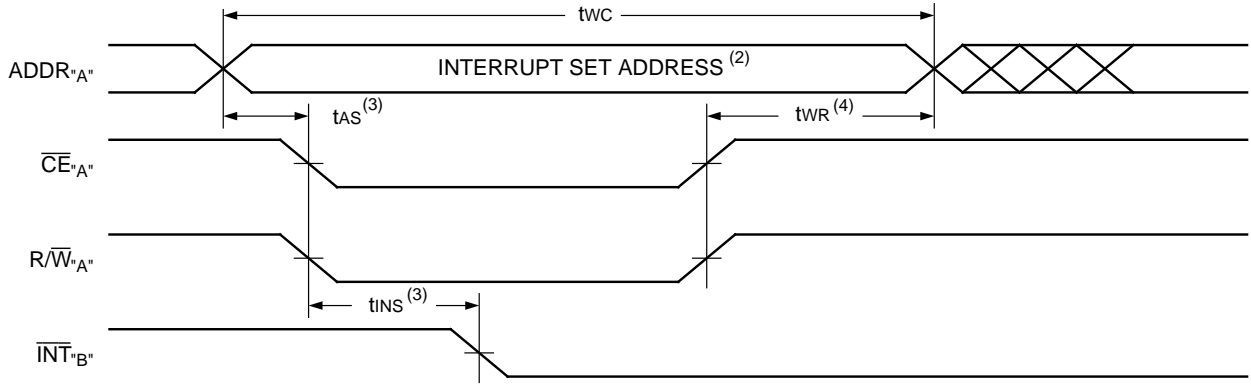

2954 drw 17

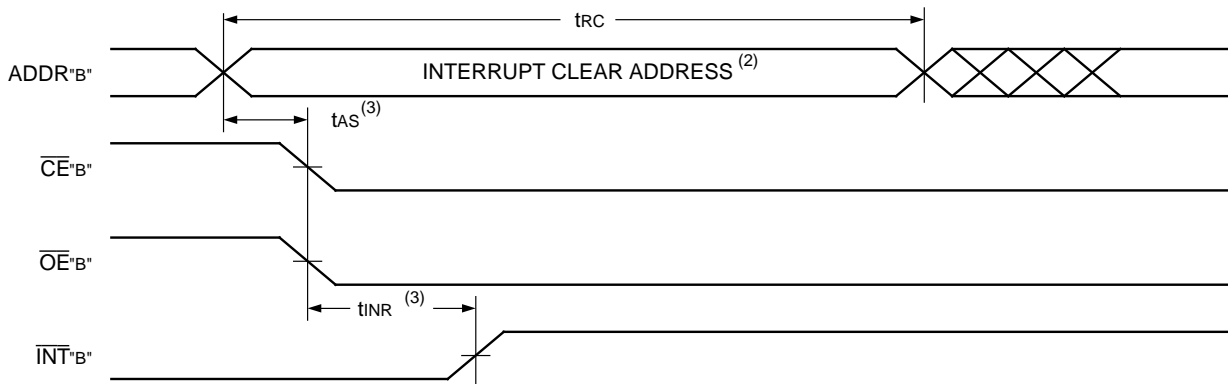

2954 drw 18

NOTES:

1. All timing is the same for left and right ports. Port "A" may be either the left or right port. Port "B" is the port opposite from "A".
2. See Interrupt truth table.
3. Timing depends on which enable signal (\overline{CE} or R/\overline{W}) is asserted last.
4. Timing depends on which enable signal (\overline{CE} or R/\overline{W}) is de-asserted first.

TRUTH TABLES

TRUTH TABLE I — INTERRUPT FLAG⁽¹⁾

Left Port					Right Port					Function
R/W _L	CE _L	OE _L	A _{12L-A_{0L}}	INT _L	R/W _R	CE _R	OE _R	A _{12R-A_{0R}}	INT _R	
L	L	X	1FFF	X	X	X	X	X	L ⁽²⁾	Set Right INT _R Flag
X	X	X	X	X	X	L	L	1FFF	H ⁽³⁾	Reset Right INT _R Flag
X	X	X	X	L ⁽³⁾	L	L	X	1FFE	X	Set Left INT _L Flag
X	L	L	1FFE	H ⁽²⁾	X	X	X	X	X	Reset Left INT _L Flag

NOTES:

1. Assumes $\overline{BUSY}_L = \overline{BUSY}_R = VIH$.
2. If $\overline{BUSY}_L = VIL$, then no change.
3. If $\overline{BUSY}_R = VIL$, then no change.

2954 tbl 15

**TRUTH TABLE II —
ADDRESS BUSY ARBITRATION**

Inputs			Outputs		Function
\overline{CE}_L	\overline{CE}_R	A0L-A12L A0R-A12R	$\overline{BUSY}_L^{(1)}$	$\overline{BUSY}_R^{(1)}$	
X	X	NO MATCH	H	H	Normal
H	X	MATCH	H	H	Normal
X	H	MATCH	H	H	Normal
L	L	MATCH	(2)	(2)	Write Inhibit ⁽³⁾

NOTES:

2954 tbl 16

1. Pins \overline{BUSY}_L and \overline{BUSY}_R are both outputs when the part is configured as a master. Both are inputs when configured as a slave. \overline{BUSY}_x outputs on the IDT7015 are push-pull, not open drain outputs. On slaves the \overline{BUSY}_x input internally inhibits writes.
2. "L" if the inputs to the opposite port were stable prior to the address and enable inputs of this port. "H" if the inputs to the opposite port became stable after the address and enable inputs of this port. If t_{APS} is not met, either \overline{BUSY}_L or \overline{BUSY}_R = Low will result. \overline{BUSY}_L and \overline{BUSY}_R outputs can not be low simultaneously.
3. Writes to the left port are internally ignored when \overline{BUSY}_L outputs are driving low regardless of actual logic level on the pin. Writes to the right port are internally ignored when \overline{BUSY}_R outputs are driving low regardless of actual logic level on the pin.

TRUTH TABLE III — EXAMPLE OF SEMAPHORE PROCUREMENT SEQUENCE^(1,2)

Functions	D0 - D8 Left	D0 - D8 Right	Status
No Action	1	1	Semaphore free
Left Port Writes "0" to Semaphore	0	1	Left port has semaphore token
Right Port Writes "0" to Semaphore	0	1	No change. Right side has no write access to semaphore
Left Port Writes "1" to Semaphore	1	0	Right port obtains semaphore token
Left Port Writes "0" to Semaphore	1	0	No change. Left port has no write access to semaphore
Right Port Writes "1" to Semaphore	0	1	Left port obtains semaphore token
Left Port Writes "1" to Semaphore	1	1	Semaphore free
Right Port Writes "0" to Semaphore	1	0	Right port has semaphore token
Right Port Writes "1" to Semaphore	1	1	Semaphore free
Left Port Writes "0" to Semaphore	0	1	Left port has semaphore token
Left Port Writes "1" to Semaphore	1	1	Semaphore free

NOTES:

2954 tbl 17

1. This table denotes a sequence of events for only one of the eight semaphores on the IDT7015.
2. There are eight semaphore flags written to via I/O0 and read from I/O0-8. These eight semaphores are addressed by A0 - A2.

FUNCTIONAL DESCRIPTION

The IDT7015 provides two ports with separate control, address and I/O pins that permit independent access for reads or writes to any location in memory. The IDT7015 has an automatic power down feature controlled by \overline{CE} . The \overline{CE} controls on-chip power down circuitry that permits the respective port to go into a standby mode when not selected (\overline{CE} High). When a port is enabled, access to the entire memory array is permitted.

memory location 1FFF and to clear the interrupt flag (\overline{INTR}), the right port must access memory location 1FFF. The message (9 bits) at 1FFE or 1FFF is user-defined since it is an addressable SRAM location. If the interrupt function is not used, address locations 1FFE and 1FFF are not used as mail boxes but are still part of the random access memory. Refer to Truth Table for the interrupt operation.

INTERRUPTS

If the user chooses to use the interrupt function, a memory location (mail box or message center) is assigned to each port. The left port interrupt flag (\overline{INT}_L) is asserted when the right port writes to memory location 1FFE where a write is defined as the $\overline{CE} = R/\overline{W} = V_{IL}$ per the Truth Table. The left port clears the interrupt by an address location 1FFE access when $\overline{CE}_R = \overline{OER} = V_{IL}$, R/\overline{W} is a "don't care". Likewise, the right port interrupt flag (\overline{INTR}) is asserted when the left port writes to

BUSY LOGIC

Busy Logic provides a hardware indication that both ports of the RAM have accessed the same location at the same time. It also allows one of the two accesses to proceed and signals the other side that the RAM is "Busy". The busy pin can then be used to stall the access until the operation on the other side is completed. If a write operation has been attempted from the side that receives a busy indication, the write signal is gated internally to prevent the write from proceeding.

The use of busy logic is not required or desirable for all

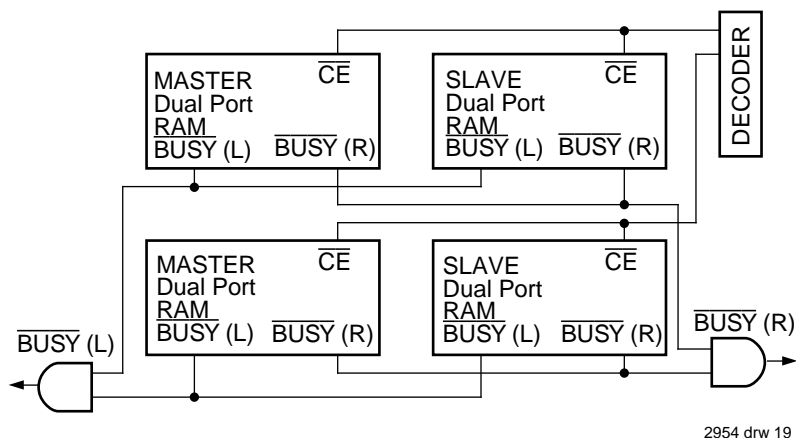

Figure 3. Busy and chip enable routing for both width and depth expansion with IDT7015 RAMs.

applications. In some cases it may be useful to logically OR the busy outputs together and use any busy indication as an interrupt source to flag the event of an illegal or illogical operation. If the write inhibit function of busy logic is not desirable, the busy logic can be disabled by placing the part in slave mode with the M/\bar{S} pin. Once in slave mode the $BUSY$ pin operates solely as a write inhibit input pin. Normal operation can be programmed by tying the \bar{BUSY} pins high. If desired, unintended write operations can be prevented to a port by tying the busy pin for that port low.

The busy outputs on the IDT7015 RAM in master mode, are push-pull type outputs and do not require pull up resistors to operate. If these RAMs are being expanded in depth, then the busy indication for the resulting array requires the use of an external AND gate.

WIDTH EXPANSION WITH BUSY LOGIC MASTER/SLAVE ARRAYS

When expanding an IDT7015 RAM array in width while using busy logic, one master part is used to decide which side of the RAM array will receive a busy indication, and to output that indication. Any number of slaves to be addressed in the same address range as the master, use the busy signal as a write inhibit signal. Thus on the IDT7015 RAM the busy pin is an output if the part is used as a master (M/\bar{S} pin = H), and the busy pin is an input if the part used as a slave (M/\bar{S} pin = L) as shown in Figure 3.

If two or more master parts were used when expanding in width, a split decision could result with one master indicating busy on one side of the array and another master indicating busy on one other side of the array. This would inhibit the write operations from one port for part of a word and inhibit the write operations from the other port for the other part of the word.

The busy arbitration, on a master, is based on the chip enable and address signals only. It ignores whether an access is a read or write. In a master/slave array, both address and chip enable must be valid long enough for a busy flag to be output from the master before the actual write pulse

can be initiated with the R/\bar{W} signal. Failure to observe this timing can result in a glitched internal write inhibit signal and corrupted data in the slave.

SEMAPHORES

The IDT7015 are extremely fast Dual-Port 8Kx9 Static RAMs with an additional 8 address locations dedicated to binary semaphore flags. These flags allow either processor on the left or right side of the Dual-Port RAM to claim a privilege over the other processor for functions defined by the system designer's software. As an example, the semaphore can be used by one processor to inhibit the other from accessing a portion of the Dual-Port RAM or any other shared resource.

The Dual-Port RAM features a fast access time, and both ports are completely independent of each other. This means that the activity on the left port in no way slows the access time of the right port. Both ports are identical in function to standard CMOS Static RAM and can be read from, or written to, at the same time with the only possible conflict arising from the simultaneous writing of, or a simultaneous READ/WRITE of, a non-semaphore location. Semaphores are protected against such ambiguous situations and may be used by the system program to avoid any conflicts in the non-semaphore portion of the Dual-Port RAM. These devices have an automatic power-down feature controlled by \bar{CE} , the Dual-Port RAM enable, and \bar{SEM} , the semaphore enable. The \bar{CE} and \bar{SEM} pins control on-chip power down circuitry that permits the respective port to go into standby mode when not selected. This is the condition which is shown in Truth Table where \bar{CE} and \bar{SEM} are both high.

Systems which can best use the IDT7015 contain multiple processors or controllers and are typically very high-speed systems which are software controlled or software intensive. These systems can benefit from a performance increase offered by the IDT7015's hardware semaphores, which provide a lockout mechanism without requiring complex programming.

Software handshaking between processors offers the maximum in system flexibility by permitting shared resources to be allocated in varying configurations. The IDT7015 does not use its semaphore flags to control any resources through hardware, thus allowing the system designer total flexibility in system architecture.

An advantage of using semaphores rather than the more common methods of hardware arbitration is that wait states are never incurred in either processor. This can prove to be a major advantage in very high-speed systems.

HOW THE SEMAPHORE FLAGS WORK

The semaphore logic is a set of eight latches which are independent of the Dual-Port RAM. These latches can be used to pass a flag, or token, from one port to the other to indicate that a shared resource is in use. The semaphores provide a hardware assist for a use assignment method called "Token Passing Allocation." In this method, the state of a semaphore latch is used as a token indicating that shared resource is in use. If the left processor wants to use this resource, it requests the token by setting the latch. This processor then verifies its success in setting the latch by reading it. If it was successful, it proceeds to assume control over the shared resource. If it was not successful in setting the latch, it determines that the right side processor has set the latch first, has the token and is using the shared resource. The left processor can then either repeatedly request that semaphore's status or remove its request for that semaphore to perform another task and occasionally attempt again to gain control of the token via the set and test sequence. Once the right side has relinquished the token, the left side should succeed in gaining control.

The semaphore flags are active low. A token is requested by writing a zero into a semaphore latch and is released when the same side writes a one to that latch.

The eight semaphore flags reside within the IDT7015 in a separate memory space from the Dual-Port RAM. This address space is accessed by placing a low input on the \overline{SEM} pin (which acts as a chip select for the semaphore flags) and using the other control pins (Address, \overline{OE} , and R/\overline{W}) as they would be used in accessing a standard static RAM. Each of the flags has a unique address which can be accessed by either side through address pins A0–A2. When accessing the semaphores, none of the other address pins has any effect.

When writing to a semaphore, only data pin Do is used. If a low level is written into an unused semaphore location, that flag will be set to a zero on that side and a one on the other side (see Table III). That semaphore can now only be modified by the side showing the zero. When a one is written into the same location from the same side, the flag will be set to a one for both sides (unless a semaphore request from the other side is pending) and then can be written to by both sides. The fact that the side which is able to write a zero into a semaphore subsequently locks out writes from the other side is what makes semaphore flags useful in interprocessor communications. (A thorough discussing on the use of this feature follows shortly.) A zero written into the same location from the other side will be stored in the semaphore request latch for that side

until the semaphore is freed by the first side.

When a semaphore flag is read, its value is spread into all data bits so that a flag that is a one reads as a one in all data bits and a flag containing a zero reads as all zeros. The read value is latched into one side's output register when that side's semaphore select (\overline{SEM}) and output enable (\overline{OE}) signals go active. This serves to disallow the semaphore from changing state in the middle of a read cycle due to a write cycle from the other side. Because of this latch, a repeated read of a semaphore in a test loop must cause either signal (\overline{SEM} or \overline{OE}) to go inactive or the output will never change.

A sequence WRITE/READ must be used by the semaphore in order to guarantee that no system level contention will occur. A processor requests access to shared resources by attempting to write a zero into a semaphore location. If the semaphore is already in use, the semaphore request latch will contain a zero, yet the semaphore flag will appear as one, a fact which the processor will verify by the subsequent read (see Table III). As an example, assume a processor writes a zero to the left port at a free semaphore location. On a subsequent read, the processor will verify that it has written successfully to that location and will assume control over the resource in question. Meanwhile, if a processor on the right side attempts to write a zero to the same semaphore flag it will fail, as will be verified by the fact that a one will be read from that semaphore on the right side during subsequent read. Had a sequence of READ/WRITE been used instead, system contention problems could have occurred during the gap between the read and write cycles.

It is important to note that a failed semaphore request must be followed by either repeated reads or by writing a one into the same location. The reason for this is easily understood by looking at the simple logic diagram of the semaphore flag in Figure 4. Two semaphore request latches feed into a semaphore flag. Whichever latch is first to present a zero to the semaphore flag will force its side of the semaphore flag low and the other side high. This condition will continue until a one is written to the same semaphore request latch. Should the other side's semaphore request latch have been written to a zero in the meantime, the semaphore flag will flip over to the other side as soon as a one is written into the first side's request latch. The second side's flag will now stay low until its semaphore request latch is written to a one. From this it is easy to understand that, if a semaphore is requested and the processor which requested it no longer needs the resource, the entire system can hang up until a one is written into that semaphore request latch.

The critical case of semaphore timing is when both sides request a single token by attempting to write a zero into it at the same time. The semaphore logic is specially designed to resolve this problem. If simultaneous requests are made, the logic guarantees that only one side receives the token. If one side is earlier than the other in making the request, the first side to make the request will receive the token. If both requests arrive at the same time, the assignment will be arbitrarily made to one port or the other.

One caution that should be noted when using semaphores is that semaphores alone do not guarantee that access to a

resource is secure. As with any powerful programming technique, if semaphores are misused or misinterpreted, a software error can easily happen.

Initialization of the semaphores is not automatic and must be handled via the initialization program at power-up. Since any semaphore request flag which contains a zero must be reset to a one, all semaphores on both sides should have a one written into them at initialization from both sides to assure that they will be free when needed.

USING SEMAPHORES—SOME EXAMPLES

Perhaps the simplest application of semaphores is their application as resource markers for the IDT7015's Dual-Port RAM. Say the 8K x 9 RAM was to be divided into two 4K x 9 blocks which were to be dedicated at any one time to servicing either the left or right port. Semaphore 0 could be used to indicate the side which would control the lower section of memory, and Semaphore 1 could be defined as the indicator for the upper section of memory.

To take a resource, in this example the lower 4K of Dual-Port RAM, the processor on the left port could write and then read a zero in to Semaphore 0. If this task were successfully completed (a zero was read back rather than a one), the left processor would assume control of the lower 4K. Meanwhile the right processor was attempting to gain control of the resource after the left processor, it would read back a one in response to the zero it had attempted to write into Semaphore 0. At this point, the software could choose to try and gain control of the second 4K section by writing, then reading a zero into Semaphore 1. If it succeeded in gaining control, it would lock out the left side.

Once the left side was finished with its task, it would write a one to Semaphore 0 and may then try to gain access to Semaphore 1. If Semaphore 1 was still occupied by the right side, the left side could undo its semaphore request and perform other tasks until it was able to write, then read a zero

into Semaphore 1. If the right processor performs a similar task with Semaphore 0, this protocol would allow the two processors to swap 4K blocks of Dual-Port RAM with each other.

The blocks do not have to be any particular size and can even be variable, depending upon the complexity of the software using the semaphore flags. All eight semaphores could be used to divide the Dual-Port RAM or other shared resources into eight parts. Semaphores can even be assigned different meanings on different sides rather than being given a common meanings on different sides as was shown in the example above.

Semaphores are a useful form of arbitration in systems like disk interfaces where the CPU must be locked out of a section of memory during a transfer and the I/O device cannot tolerate any wait states. With the use of semaphores, once the two devices has determined which memory area was "off-limits" to the CPU, both the CPU and the I/O devices could access their assigned portions of memory continuously without any wait states.

Semaphores are also useful in applications where no memory "WAIT" state is available on one or both sides. Once a semaphore handshake has been performed, both processors can access their assigned RAM segments at full speed.

Another application is in the area of complex data structures. In this case, block arbitration is very important. For this application one processor may be responsible for building and updating a data structure. The other processor then reads and interprets that data structure. If the interpreting processor reads an incomplete data structure, a major error condition may exist. Therefore, some sort of arbitration must be used between the two different processors. The building processor arbitrates for the block, locks it and then is able to go in and update the data structure. When the update is completed, the data structure block is released. This allows the interpreting processor to come back and read the complete data structure, thereby guaranteeing a consistent data structure.

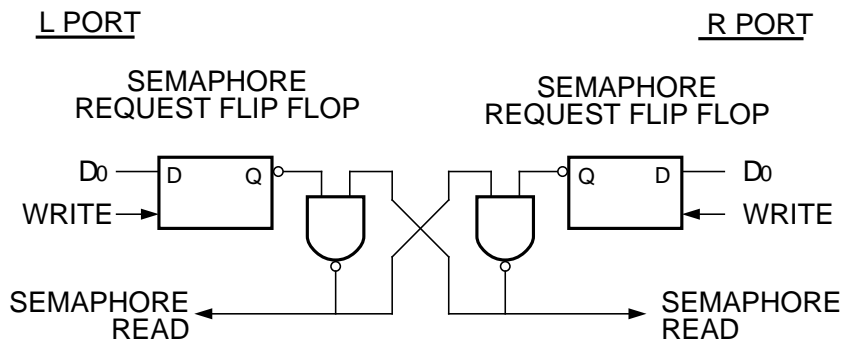

2954 drw 20

Figure 4. IDT7015 Semaphore Logic

ORDERING INFORMATION

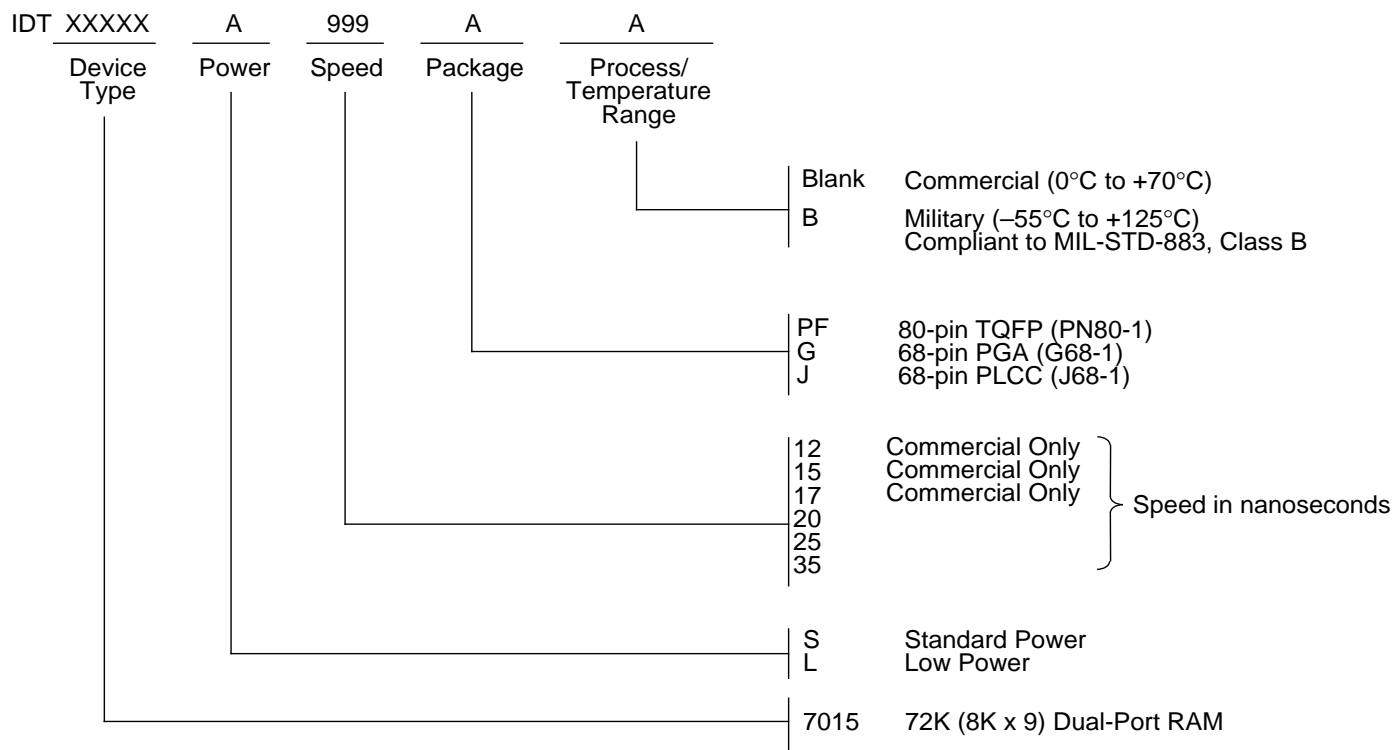

2954 drw 21