



Integrated Device Technology, Inc.

# LOW POWER 2V CMOS SRAM 1 MEG (64K x 16-BIT)

**ADVANCE  
INFORMATION  
IDT71T016**

## FEATURES:

- 64K x 16 Organization
- Wide Operating Voltage Range: 1.8 to 2.7V
- Speed Grades: 150ns, 200ns
- Low Operating Power: 20mA (max)
- Low Standby Power: 5µA (max)
- Low-Voltage Data Retention: 1.5V (min)
- Available in a 44-pin TSOP package

## DESCRIPTION:

The IDT71T016 is a 1,048,576-bit very low-power Static RAM organized as 64K x 16. It is fabricated using IDT's high-reliability CMOS technology. This state-of-the-art technology, combined with innovative circuit design techniques, provides a cost-effective solution for low-power memory needs. It uses a 6-transistor memory cell.

Operation is from a single extended-range 2.5V supply. This extended supply range makes the device ideally suited for unregulated battery-powered applications. Fully static asynchronous circuitry is used, requiring no clocks or refresh for operation.

The IDT71T016 is packaged in a JEDEC standard 44-pin TSOP Type II.

## FUNCTIONAL BLOCK DIAGRAM

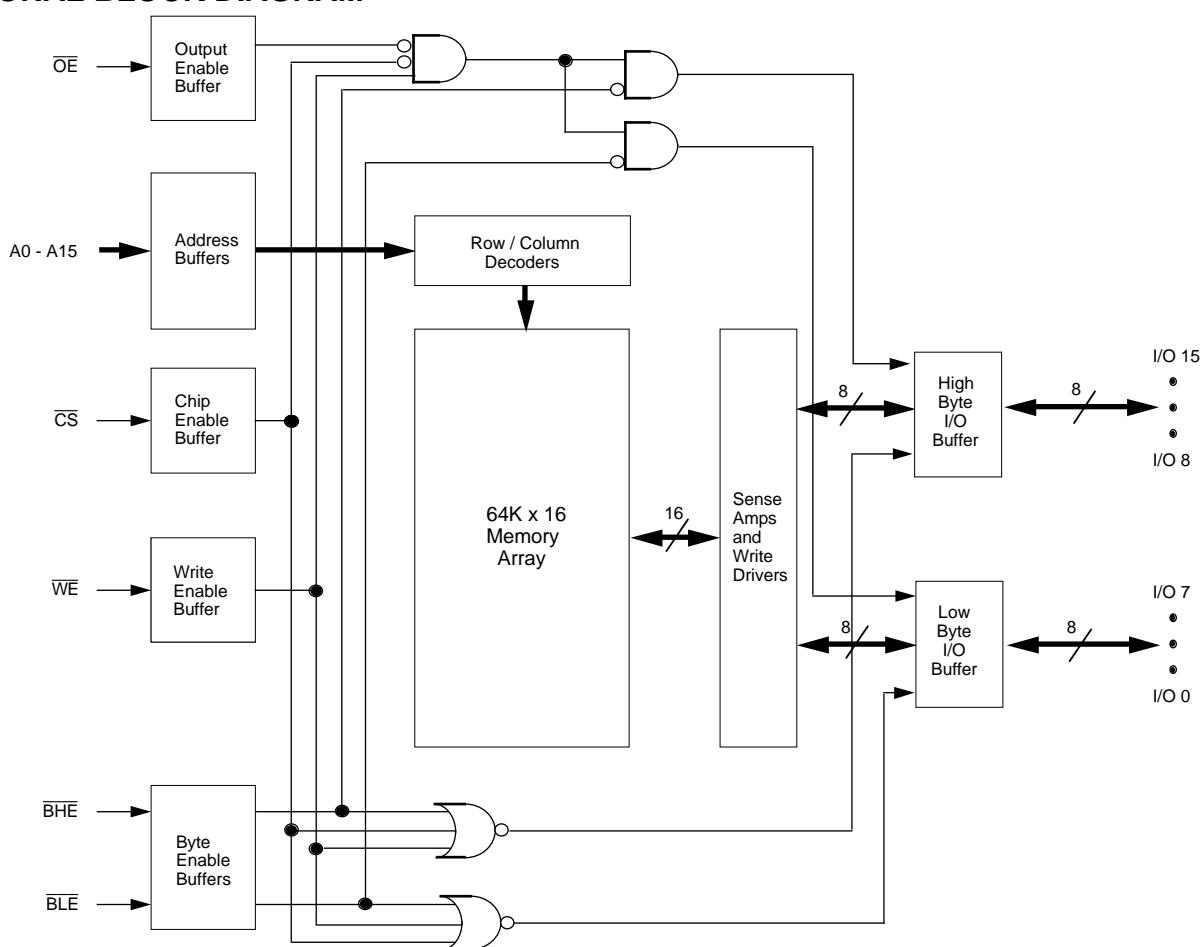

## PIN CONFIGURATIONS

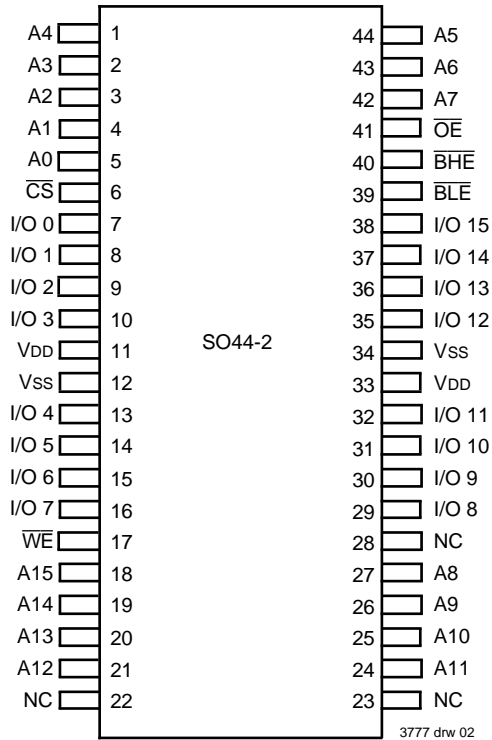

TSOP  
 TOP VIEW

## CAPACITANCE

( $T_A = +25^\circ\text{C}$ ,  $f = 1.0\text{MHz}$ )

Symbol	Parameter <sup>(1)</sup>	Conditions	Max.	Unit
$C_{IN}$	Input Capacitance	$V_{IN} = 1\text{dV}$	6	pF
$C_{I/O}$	I/O Capacitance	$V_{OUT} = 1\text{dV}$	7	pF

**NOTE:**

3777 tbl 06

1. This parameter is guaranteed by device characterization, but not production tested.

## PIN DESCRIPTIONS

A0 – A15	Address Inputs	Input
$\overline{CS}$	Chip Select	Input
$\overline{WE}$	Write Enable	Input
$\overline{OE}$	Output Enable	Input
$\overline{BHE}$	High Byte Enable	Input
$\overline{BLE}$	Low Byte Enable	Input
I/O <sub>0</sub> - I/O <sub>15</sub>	Data Input/Output	I/O
VDD	Power	Pwr
VSS	Ground	Gnd

3777 tbl 01

## TRUTH TABLE<sup>(1)</sup>

$\overline{CS}$	$\overline{OE}$	$\overline{WE}$	$\overline{BLE}$	$\overline{BHE}$	I/O <sub>0</sub> -I/O <sub>7</sub>	I/O <sub>8</sub> -I/O <sub>15</sub>	Function
H	X	X	X	X	High-Z	High-Z	Deselected - Standby
L	L	H	L	H	DATAOUT	High-Z	Low Byte Read
L	L	H	H	L	High-Z	DATAOUT	High Byte Read
L	L	H	L	L	DATAOUT	DATAOUT	Word Read
L	X	L	L	L	DATAIN	DATAIN	Word Write
L	X	L	L	H	DATAIN	High-Z	Low Byte Write
L	X	L	H	L	High-Z	DATAIN	High Byte Write
L	H	H	X	X	High-Z	High-Z	Outputs Disabled
L	X	X	H	H	High-Z	High-Z	Outputs Disabled

**NOTE:**

3777 tbl 02

1.H =  $V_{IH}$ , L =  $V_{IL}$ , X = Don't care.

### ABSOLUTE MAXIMUM RATINGS<sup>(1)</sup>

Symbol	Rating	Com'l. and Ind'l.	Unit
V <sub>TERM</sub> <sup>(2)</sup>	Terminal Voltage with Respect to VSS	-0.5 to +3.6	V
V <sub>TERM</sub> <sup>(3)</sup>	Terminal Voltage with Respect to VSS	-0.5 to V <sub>DD</sub> + 0.5	V
T <sub>BIAS</sub>	Temperature Under Bias	-55 to +125	°C
T <sub>STG</sub>	Storage Temperature	-55 to +125	°C
PT	Power Dissipation	1.0	W
I <sub>OUT</sub>	DC Output Current	20	mA

**NOTES:**

3777 tbl 03

- Stresses greater than those listed under ABSOLUTE MAXIMUM RATINGS may cause permanent damage to the device. This is a stress rating only and functional operation of the device at these or any other conditions above those indicated in the operational sections of this specification is not implied. Exposure to absolute maximum rating conditions for extended periods may affect reliability.
- V<sub>DD</sub> terminals only.
- Input, Output, and I/O terminals; 3.6V maximum.

### RECOMMENDED OPERATING TEMPERATURE AND SUPPLY VOLTAGE

Grade	Temperature	VSS	VDD
Commercial	0°C to +70°C	0V	1.8V to 2.7V
Industrial	-40°C to +85°C	0V	1.8V to 2.7V

3777 tbl 04

### RECOMMENDED DC OPERATING CONDITIONS

Symbol	Parameter	Min.	Max.	Unit
V <sub>DD</sub>	Supply Voltage	1.8	2.7	V
V <sub>SS</sub>	Ground	0	0	V
V <sub>IH</sub>	Input High Voltage	V <sub>DD</sub> x 0.7	V <sub>DD</sub> + 0.3 <sup>(1)</sup>	V
V <sub>IL</sub>	Input Low Voltage	-0.3 <sup>(2)</sup>	V <sub>DD</sub> x 0.3	V

**NOTE:**

3777 tbl 05

- V<sub>IH</sub> (max.) = V<sub>DD</sub> + 1.5V for pulse width less than 5ns, once per cycle.
- V<sub>IL</sub> (min.) = -1.5V for pulse width less than 5ns, once per cycle.

### DC ELECTRICAL CHARACTERISTICS

V<sub>DD</sub> = 1.8V to 2.7V, Commercial and Industrial Temperature Ranges

Symbol	Parameter	Test Conditions	Min.	Max.	Unit
I <sub>LI</sub>	Input Leakage Current	V <sub>DD</sub> = Max., V <sub>IN</sub> = V <sub>SS</sub> to V <sub>DD</sub>	—	1	μA
I <sub>LO</sub>	Output Leakage Current	V <sub>DD</sub> = Max., $\overline{CS}$ = V <sub>IH</sub> , V <sub>OUT</sub> = V <sub>SS</sub> to V <sub>DD</sub>	—	1	μA
V <sub>OH</sub>	Output High Voltage	V <sub>DD</sub> = 1.8 to 2.7V I <sub>OH</sub> = -0.3mA	V <sub>DD</sub> - 0.2	—	V
		V <sub>DD</sub> = 2.3V I <sub>OH</sub> = -2.0mA	1.7	—	
V <sub>OL</sub>	Output Low Voltage	V <sub>DD</sub> = 1.8 to 2.7V I <sub>OL</sub> = 0.3mA	—	0.2	V
		V <sub>DD</sub> = 2.3V I <sub>OL</sub> = 2mA	—	0.4	

3777 tbl 07

### DC ELECTRICAL CHARACTERISTICS<sup>(1, 2)</sup>

V<sub>DD</sub> = 1.8 to 2.7V, V<sub>LC</sub> = 0.2V, V<sub>HC</sub> = V<sub>DD</sub>-0.2V, Commercial and Industrial Temperature Ranges

Symbol	Parameter	Test Conditions	Typ. <sup>(5)</sup>	Max.	Unit
I <sub>CC2</sub>	Dynamic Operating Current	$\overline{CS}$ = V <sub>LC</sub> , Outputs Open, V <sub>DD</sub> = 2.7V, f = f <sub>MAX</sub> <sup>(3)</sup>	-70 ns	20	mA
			-100 ns	17	
I <sub>CC</sub>	Static Operating Current	$\overline{CS}$ = V <sub>LC</sub> , Outputs Open, $\overline{WE}$ = V <sub>HC</sub> , V <sub>DD</sub> = 2.7V, f = 0 <sup>(4)</sup>	—	8	mA
I <sub>SB1</sub>	Standby Supply Current	$\overline{CS}$ = V <sub>HC</sub> , Outputs Open, V <sub>DD</sub> = 2.7V	-40 to 85°C	10	μA
			0 to 70°C	5	
			40°C	2	
			25°C	1	

**NOTES:**

3777 tbl 08

- All values are maximum guaranteed values.
- Input low and high voltage levels are 0.2V and V<sub>DD</sub>-0.2V respectively for all tests.
- f<sub>MAX</sub> = 1/trc (all address inputs are cycling at f<sub>MAX</sub>).
- f = 0 means no address input lines are changing.
- Typical conditions are V<sub>DD</sub> = 2.0V and specified temperature.

### DATA RETENTION CHARACTERISTICS OVER ALL TEMPERATURE RANGES

( $V_{LC} = 0.2V$ ,  $V_{HC} = V_{DD} - 0.2V$ )

Symbol	Parameter	Test Condition	Min.	Typ. <sup>(1)</sup>	Max.	Unit
V <sub>DR</sub>	V <sub>CC</sub> for Data Retention	—	1.5	—	—	V
I <sub>CCDR</sub>	Data Retention Current	$\overline{CS} \geq V_{HC}$	—	<1	5	$\mu A$
t <sub>CDR</sub> <sup>(3)</sup>	Chip Deselect to Data Retention Time		0	—	—	ns
t <sub>R</sub> <sup>(3)</sup>	Operation Recovery Time		t <sub>RC</sub> <sup>(2)</sup>	—	—	ns

**NOTES:**

1. T<sub>A</sub> = +25°C.
2. t<sub>RC</sub> = Read Cycle Time.
3. This parameter is guaranteed by device characterization, but is not production tested.

3777 tbl 09

### LOW V<sub>DD</sub> DATA RETENTION WAVEFORM

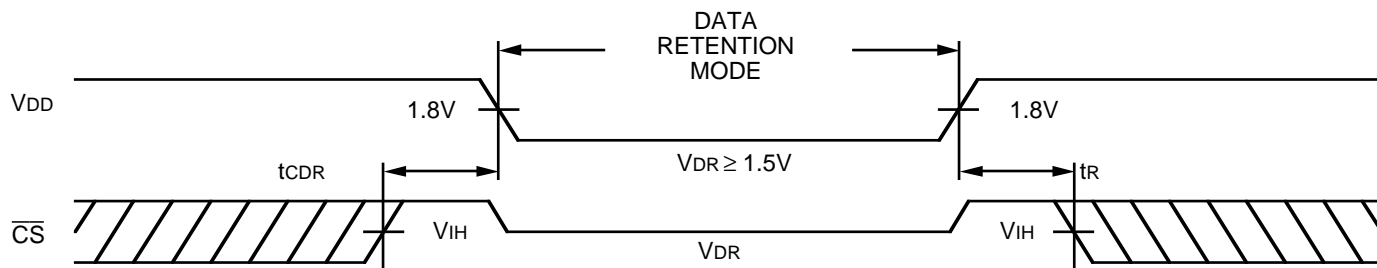

3777 drw 05

### AC TEST CONDITIONS

Input Pulse Levels	GND to V <sub>DD</sub>
Input Rise/Fall Times	3ns
Input Timing Reference Levels	V <sub>DD</sub> x 0.5
Output Reference Levels	V <sub>DD</sub> x 0.5
AC Test Load	See Figure 1

3777 tbl 09

### AC TEST LOAD

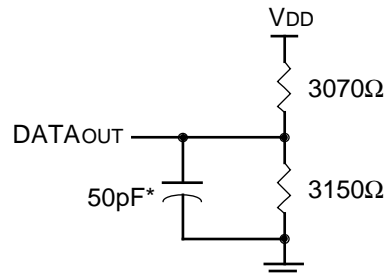

3777 drw 04

\*Including jig and scope capacitance.

Figure 1. AC Test Load

**AC ELECTRICAL CHARACTERISTICS** ( $V_{DD} = 1.8$  to  $2.7V$ , All Temperature Ranges)

Symbol	Parameter	71T016L150		71T016L200		Units
		Min.	Max.	Min.	Max.	
<b>Read Cycle</b>						
t <sub>RC</sub>	Read Cycle Time	150	—	200	—	ns
t <sub>AA</sub>	Address Access Time	—	150	—	200	ns
t <sub>ACS</sub>	Chip Select Access Time	—	150	—	200	ns
t <sub>CLZ</sub> <sup>(1)</sup>	Chip Select Low to Output in Low-Z	20	—	20	—	ns
t <sub>CHZ</sub> <sup>(1)</sup>	Chip Select High to Output in High-Z	—	30	—	40	ns
t <sub>OE</sub>	Output Enable Low to Output Valid	—	75	—	100	ns
t <sub>OLZ</sub> <sup>(1)</sup>	Output Enable Low to Output in Low-Z	20	—	20	—	ns
t <sub>OHZ</sub> <sup>(1)</sup>	Output Enable High to Output in High-Z	—	30	—	40	ns
t <sub>OH</sub>	Output Hold from Address Change	15	—	15	—	ns
t <sub>BE</sub>	Byte Enable Low to Output Valid	—	75	—	100	ns
t <sub>BLZ</sub> <sup>(1)</sup>	Byte Enable Low to Output in Low-Z	20	—	20	—	ns
t <sub>BHZ</sub> <sup>(1)</sup>	Byte Enable High to Output in High-Z	—	30	—	40	ns
<b>Write Cycle</b>						
t <sub>WC</sub>	Write Cycle Time	150	—	200	—	ns
t <sub>AW</sub>	Address Valid to End of Write	120	—	160	—	ns
t <sub>CW</sub>	Chip Select Low to End of Write	120	—	160	—	ns
t <sub>BW</sub>	Byte Enable Low to End of Write	120	—	160	—	ns
t <sub>AS</sub>	Address Set-up Time	0	—	0	—	ns
t <sub>WR</sub>	Address Hold from End of Write	0	—	0	—	ns
t <sub>WP</sub>	Write Pulse Width	100	—	140	—	ns
t <sub>DW</sub>	Data Valid to End of Write	60	—	80	—	ns
t <sub>DH</sub>	Data Hold Time	0	—	0	—	ns
t <sub>OW</sub> <sup>(1)</sup>	Write Enable High to Output in Low-Z	5	—	5	—	ns
t <sub>WHZ</sub> <sup>(1)</sup>	Write Enable Low to Output in High-Z	—	40	—	50	ns

**NOTE:**

1. This parameter is guaranteed by device characterization, but is not production tested.

3777 tbl 10

**TIMING WAVEFORM OF READ CYCLE NO. 1<sup>(1,2,3)</sup>**

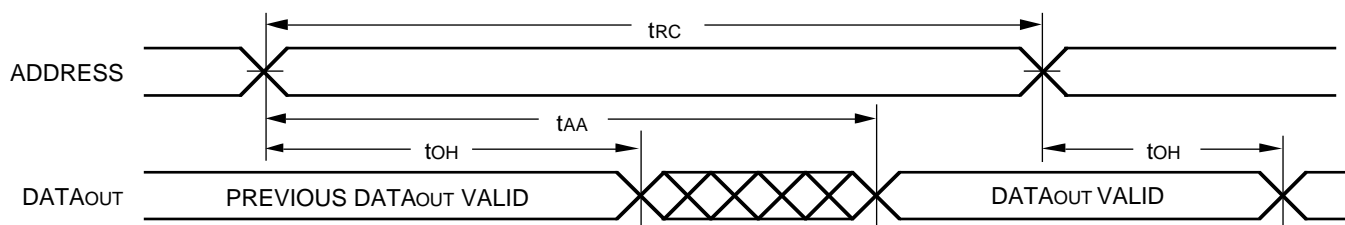

3777 drw 06

**NOTES:**

1.  $\overline{WE}$  is HIGH for Read Cycle.
2. Device is continuously selected,  $\overline{CS}$  is LOW.
3.  $\overline{OE}$ ,  $\overline{BHE}$ , and  $\overline{BLE}$  are LOW.

### TIMING WAVEFORM OF READ CYCLE NO. 2<sup>(1)</sup>

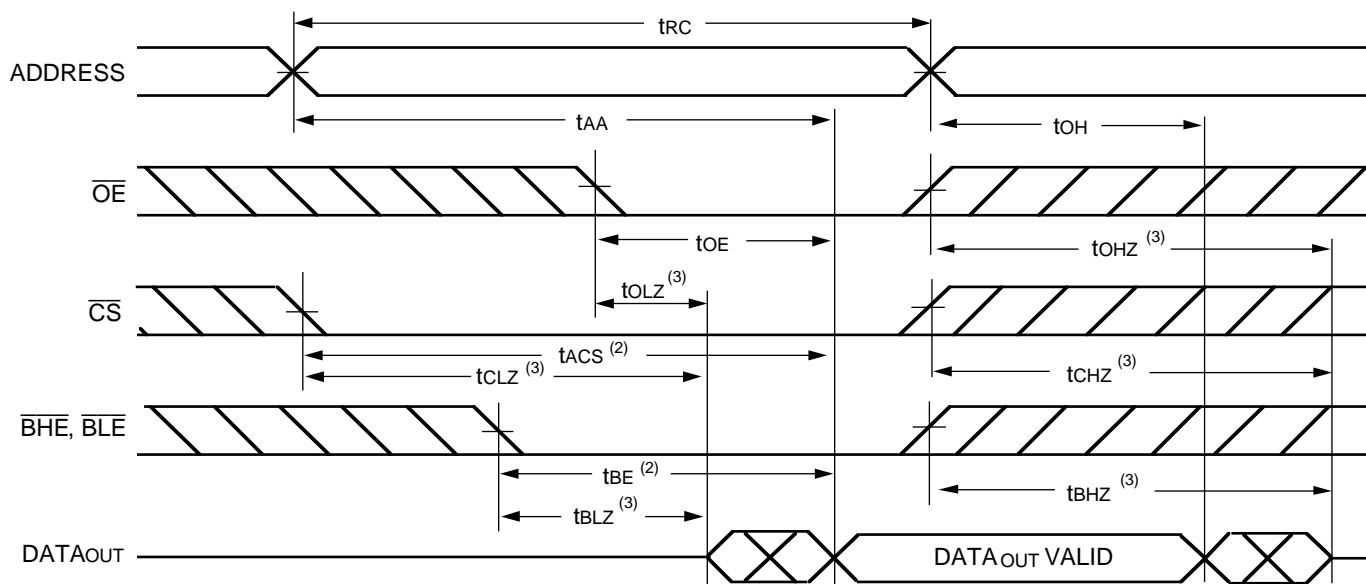

**NOTES:**

1.  $\overline{WE}$  is HIGH for Read Cycle.
2. Address must be valid prior to or coincident with the later of  $\overline{CS}$ ,  $\overline{BHE}$ , or  $\overline{BLE}$  transition LOW; otherwise  $t_{AA}$  is the limiting parameter.
3. Transition is measured  $\pm 200\text{mV}$  from steady state.

3777 drw 07

### TIMING WAVEFORM OF WRITE CYCLE NO. 1 ( $\overline{WE}$ CONTROLLED TIMING)<sup>(1,2,3,5)</sup>

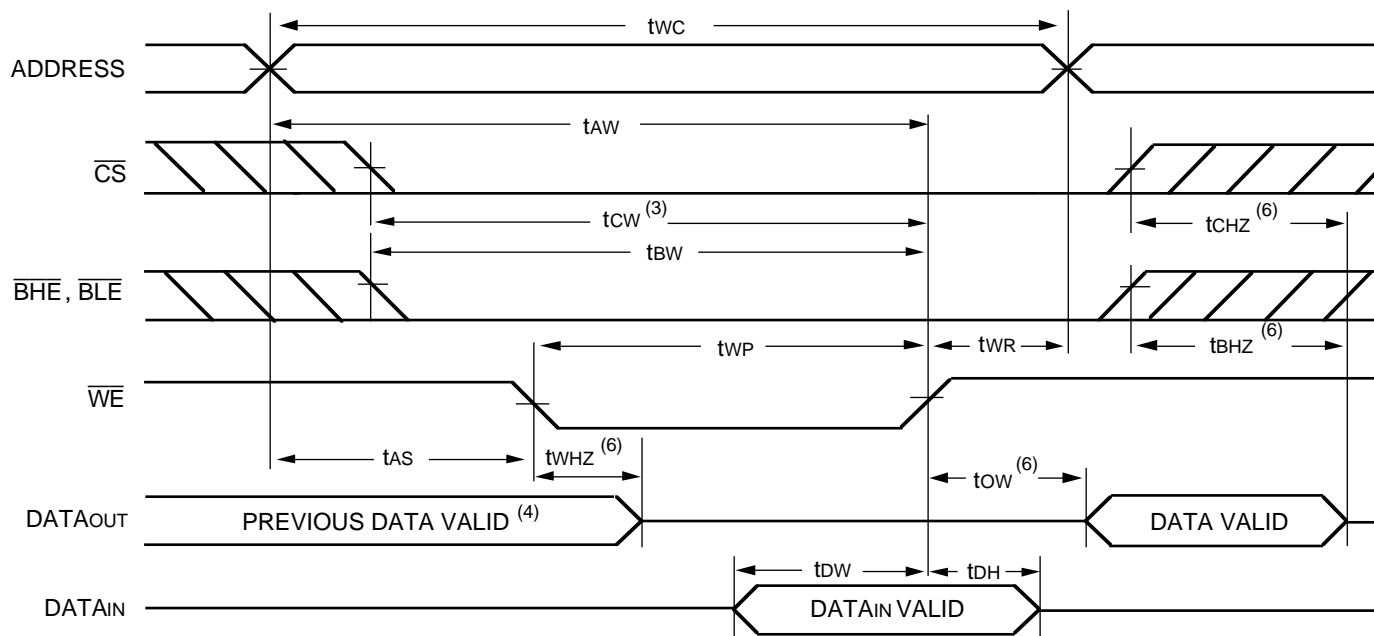

**NOTES:**

1.  $\overline{WE}$  or ( $\overline{BHE}$  and  $\overline{BLE}$ ) or  $\overline{CS}$  must be HIGH during all address transitions.
2. A write occurs during the overlap of a LOW  $\overline{CS}$ , LOW  $\overline{BHE}$  or  $\overline{BLE}$ , and a LOW  $\overline{WE}$ .
3.  $\overline{OE}$  is continuously HIGH. If during a  $\overline{WE}$  controlled write cycle  $\overline{OE}$  is LOW,  $t_{WP}$  must be greater than or equal to  $t_{WHZ} + t_{BW}$  to allow the I/O drivers to turn off and data to be placed on the bus for the required  $t_{DW}$ . If  $\overline{OE}$  is HIGH during a  $\overline{WE}$  controlled write cycle, this requirement does not apply and the minimum write pulse is as short as the specified  $t_{WP}$ .
4. During this period, I/O pins are in the output state, and input signals must not be applied.
5. If the  $\overline{CS}$  LOW or  $\overline{BHE}$  and  $\overline{BLE}$  LOW transition occurs simultaneously with or after the  $\overline{WE}$  LOW transition, the outputs remain in a high-impedance state.
6. Transition is measured  $\pm 200\text{mV}$  from steady state.

3777 drw 08

### TIMING WAVEFORM OF WRITE CYCLE NO. 2 ( $\overline{\text{CS}}$ CONTROLLED TIMING)<sup>(1,2,5)</sup>

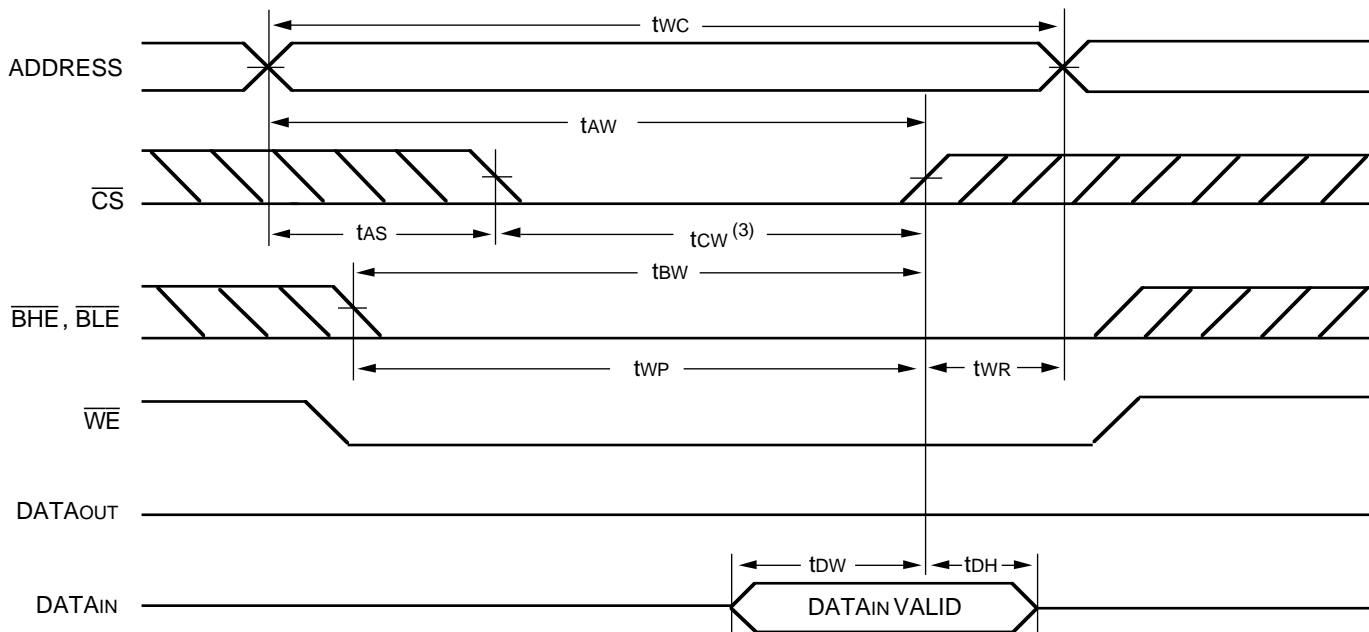

3777 drw 09

### TIMING WAVEFORM OF WRITE CYCLE NO. 3 ( $\overline{\text{BHE}}, \overline{\text{BLE}}$ CONTROLLED TIMING)<sup>(1,2,5)</sup>

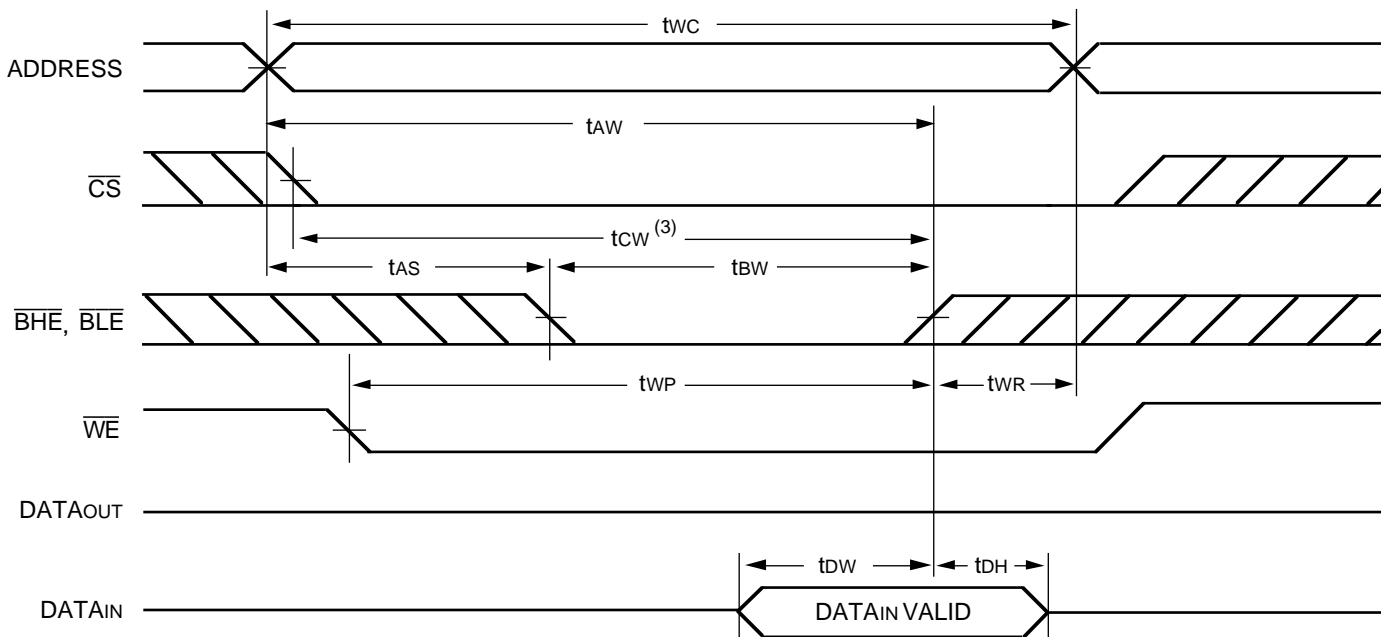

3777 drw 10

#### NOTES:

- $\overline{\text{WE}}$  or ( $\overline{\text{BHE}}$  and  $\overline{\text{BLE}}$ ) or  $\overline{\text{CS}}$  must be HIGH during all address transitions.
- A write occurs during the overlap of a LOW  $\overline{\text{CS}}$ , LOW  $\overline{\text{BHE}}$  or  $\overline{\text{BLE}}$ , and a LOW  $\overline{\text{WE}}$ .
- $\overline{\text{OE}}$  is continuously HIGH. If during a  $\overline{\text{WE}}$  controlled write cycle  $\overline{\text{OE}}$  is LOW,  $t_{\text{WP}}$  must be greater than or equal to  $t_{\text{WHZ}} + t_{\text{DW}}$  to allow the I/O drivers to turn off and data to be placed on the bus for the required  $t_{\text{DW}}$ . If  $\overline{\text{OE}}$  is HIGH during a  $\overline{\text{WE}}$  controlled write cycle, this requirement does not apply and the minimum write pulse is as short as the specified  $t_{\text{WP}}$ .
- During this period, I/O pins are in the output state, and input signals must not be applied.
- If the  $\overline{\text{CS}}$  LOW or  $\overline{\text{BHE}}$  and  $\overline{\text{BLE}}$  LOW transition occurs simultaneously with or after the  $\overline{\text{WE}}$  LOW transition, the outputs remain in a high-impedance state.
- Transition is measured  $\pm 200\text{mV}$  from steady state.

### ORDERING INFORMATION

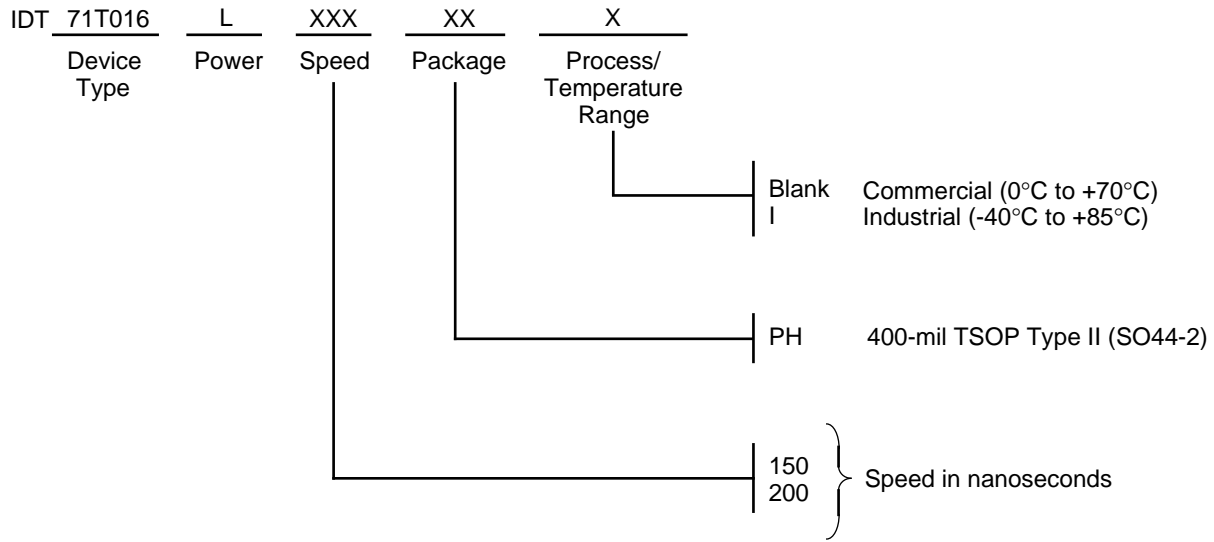

3777 drw 11