



**HIGH-SPEED 2.5V
512/256K x 18
ASYNCHRONOUS DUAL-PORT
STATIC RAM
WITH 3.3V OR 2.5V INTERFACE**

**PRELIMINARY
IDT70T633/1S**

Features

- ◆ True Dual-Port memory cells which allow simultaneous access of the same memory location
- ◆ High-speed access
 - Commercial: 8/10/12/15ns (max.)
 - Industrial: 10/12ns (max.)
- ◆ RapidWrite Mode simplifies high-speed consecutive write cycles
- ◆ Dual chip enables allow for depth expansion without external logic
- ◆ IDT70T633/1 easily expands data bus width to 36 bits or more using the Master/Slave select when cascading more than one device
- ◆ $M/\overline{S} = V_{IH}$ for \overline{BUSY} output flag on Master, $M/\overline{S} = V_{IL}$ for \overline{BUSY} input on Slave
- ◆ Busy and Interrupt Flags

- ◆ Full hardware support of semaphore signaling between ports on-chip
- ◆ On-chip port arbitration logic
- ◆ Fully asynchronous operation from either port
- ◆ Separate byte controls for multiplexed bus and bus matching compatibility
- ◆ Sleep Mode Inputs on both ports
- ◆ Supports JTAG features compliant to IEEE 1149.1 in BGA-208 and BGA-256 packages
- ◆ Single 2.5V ($\pm 100mV$) power supply for core
- ◆ LVTTTL-compatible, selectable 3.3V ($\pm 150mV$)/2.5V ($\pm 100mV$) power supply for I/Os and control signals on each port
- ◆ Available in a 256-ball Ball Grid Array, 144-pin Thin Quad Flatpack and 208-ball fine pitch Ball Grid Array
- ◆ Industrial temperature range ($-40^{\circ}C$ to $+85^{\circ}C$) is available for selected speeds

Functional Block Diagram

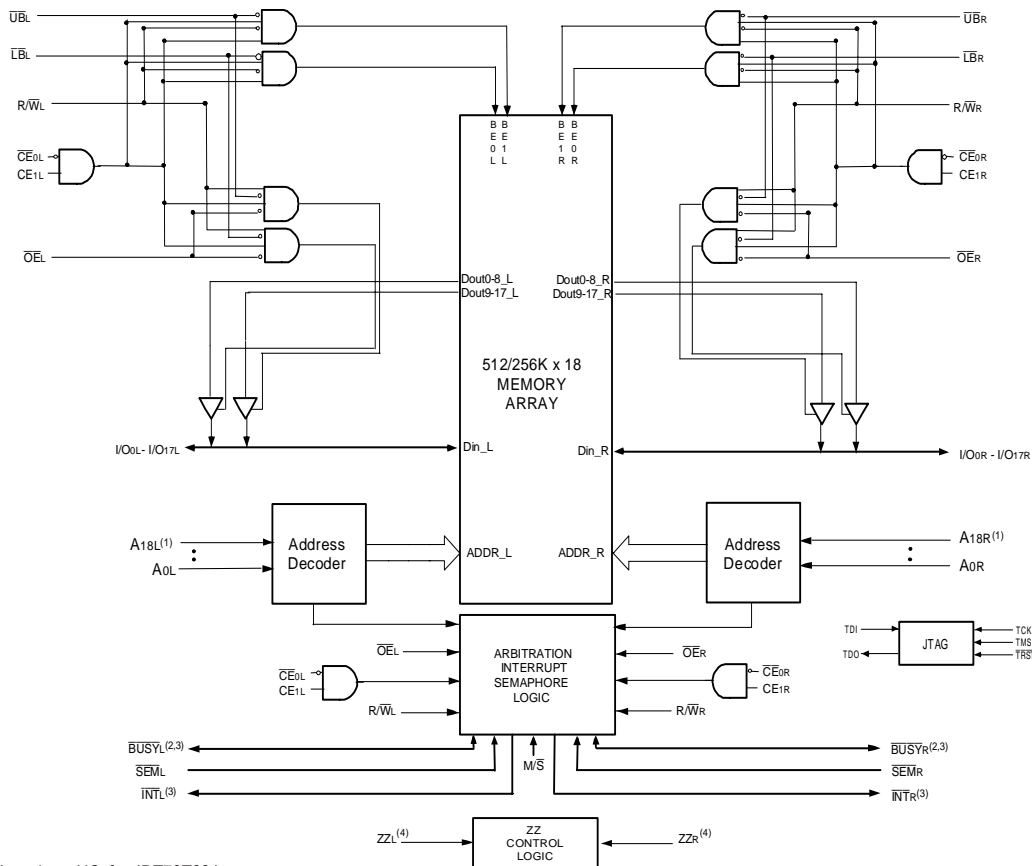

NOTES:

1. Address A18x is a NC for IDT70T631.
2. \overline{BUSY} is an input as a Slave ($M/\overline{S}=V_{IL}$) and an output when it is a Master ($M/\overline{S}=V_{IH}$).
3. \overline{BUSY} and \overline{INT} are non-tri-state totem-pole outputs (push-pull).
4. The sleep mode pin shuts off all dynamic inputs, except JTAG inputs, when asserted. $OPTx$, \overline{INTx} , M/\overline{S} and the sleep mode pins themselves (ZZx) are not affected during sleep mode.

5670 drw 01

NOVEMBER 2003

Description

The IDT70T633/1 is a high-speed 512/256K x 18 Asynchronous Dual-Port Static RAM. The IDT70T633/1 is designed to be used as a stand-alone 9216/4608K-bit Dual-Port RAM or as a combination MASTER/SLAVE Dual-Port RAM for 36-bit-or-more word system. Using the IDT MASTER/SLAVE Dual-Port RAM approach in 36-bit or wider memory system applications results in full-speed, error-free operation without the need for additional discrete logic.

This device provides two independent ports with separate control, address, and I/O pins that permit independent, asynchronous access for reads or writes to any location in memory. An automatic power down

feature controlled by the chip enables (either $\overline{CE0}$ or $CE1$) permit the on-chip circuitry of each port to enter a very low standby power mode.

The IDT70T651/9 has a RapidWrite Mode which allows the designer to perform back-to-back write operations without pulsing the R/\overline{W} input each cycle. This is especially significant at the 8 and 10ns cycle times of the IDT70T651/9, easing design considerations at these high performance levels.

The 70T633/1 can support an operating voltage of either 3.3V or 2.5V on one or both ports, controlled by the OPT pins. The power supply for the core of the device (V_{DD}) remains at 2.5V.

Pin Configuration^(1,2,3)

70T633/1BC
BC-256^(5,6)

256-Pin BGA
Top View

03/13/03

A1	A2	A3	A4	A5	A6	A7	A8	A9	A10	A11	A12	A13	A14	A15	A16
NC	TDI	NC	A17L	A14L	A11L	A8L	NC	CE1L	\overline{OE} L	\overline{INT} L	A5L	A2L	A0L	NC	NC
B1	B2	B3	B4	B5	B6	B7	B8	B9	B10	B11	B12	B13	B14	B15	B16
NC	NC	TDO	A18L ⁽⁴⁾	A15L	A12L	A9L	\overline{UB} L	\overline{CE} 0L	R/ \overline{WL}	NC	A4L	A1L	NC	NC	NC
C1	C2	C3	C4	C5	C6	C7	C8	C9	C10	C11	C12	C13	C14	C15	C16
NC	I/O9L	VSS	A16L	A13L	A10L	A7L	NC	\overline{LB} L	\overline{SEM} L	\overline{BUSY} L	A6L	A3L	OPTL	NC	I/O8L
D1	D2	D3	D4	D5	D6	D7	D8	D9	D10	D11	D12	D13	D14	D15	D16
NC	I/O9R	NC	VDD	VDDQL	VDDQL	VDDQR	VDDQR	VDDQL	VDDQL	VDDQR	VDDQR	VDD	NC	NC	I/O8R
E1	E2	E3	E4	E5	E6	E7	E8	E9	E10	E11	E12	E13	E14	E15	E16
I/O10R	I/O10L	NC	VDDQL	VDD	VDD	VSS	VSS	VSS	VSS	VDD	VDD	VDDQR	NC	I/O7L	I/O7R
F1	F2	F3	F4	F5	F6	F7	F8	F9	F10	F11	F12	F13	F14	F15	F16
I/O11L	NC	I/O11R	VDDQL	VDD	NC	VSS	VSS	VSS	VSS	VSS	VDD	VDDQR	I/O6R	NC	I/O6L
G1	G2	G3	G4	G5	G6	G7	G8	G9	G10	G11	G12	G13	G14	G15	G16
NC	NC	I/O12L	VDDQR	VSS	VSS	VSS	VSS	VSS	VSS	VSS	VSS	VDDQL	I/O5L	NC	NC
H1	H2	H3	H4	H5	H6	H7	H8	H9	H10	H11	H12	H13	H14	H15	H16
NC	I/O12R	NC	VDDQR	VSS	VSS	VSS	VSS	VSS	VSS	VSS	VSS	VDDQL	NC	NC	I/O5R
J1	J2	J3	J4	J5	J6	J7	J8	J9	J10	J11	J12	J13	J14	J15	J16
I/O13L	I/O14R	I/O13R	VDDQL	ZZR	VSS	VSS	VSS	VSS	VSS	VSS	ZZL	VDDQR	I/O4R	I/O3R	I/O4L
K1	K2	K3	K4	K5	K6	K7	K8	K9	K10	K11	K12	K13	K14	K15	K16
NC	NC	I/O14L	VDDQL	VSS	VSS	VSS	VSS	VSS	VSS	VSS	VSS	VDDQR	NC	NC	I/O3L
L1	L2	L3	L4	L5	L6	L7	L8	L9	L10	L11	L12	L13	L14	L15	L16
I/O15L	NC	I/O15R	VDDQR	VDD	NC	VSS	VSS	VSS	VSS	VSS	VDD	VDDQL	I/O2L	NC	I/O2R
M1	M2	M3	M4	M5	M6	M7	M8	M9	M10	M11	M12	M13	M14	M15	M16
I/O16R	I/O16L	NC	VDDQR	VDD	VDD	VSS	VSS	VSS	VSS	VDD	VDD	VDDQL	I/O1R	I/O1L	NC
N1	N2	N3	N4	N5	N6	N7	N8	N9	N10	N11	N12	N13	N14	N15	N16
NC	I/O17R	NC	VDD	VDDQR	VDDQR	VDDQL	VDDQL	VDDQR	VDDQR	VDDQL	VDDQL	VDD	NC	I/O0R	NC
P1	P2	P3	P4	P5	P6	P7	P8	P9	P10	P11	P12	P13	P14	P15	P16
NC	I/O17L	TMS	A16R	A13R	A10R	A7R	NC	\overline{LB} R	\overline{SEM} R	\overline{BUSY} R	A6R	A3R	NC	NC	I/O0L
R1	R2	R3	R4	R5	R6	R7	R8	R9	R10	R11	R12	R13	R14	R15	R16
NC	NC	\overline{TRST}	A18R ⁽⁴⁾	A15R	A12R	A9R	\overline{UB} R	\overline{CE} 0R	R/ \overline{WR}	M/ \overline{S}	A4R	A1R	OPTR	NC	NC
T1	T2	T3	T4	T5	T6	T7	T8	T9	T10	T11	T12	T13	T14	T15	T16
NC	TCK	NC	A17R	A14R	A11R	A8R	NC	CE1R	\overline{OE} R	\overline{INT} R	A5R	A2R	A0R	NC	NC

5670 drw 02c

NOTES:

1. All VDD pins must be connected to 2.5V power supply.
2. All VDDQ pins must be connected to appropriate power supply: 3.3V if OPT pin for that port is set to VDD (2.5V), and 2.5V if OPT pin for that port is set to VSS (0V).
3. All VSS pins must be connected to ground supply.
4. A18x is a NC for IDT70T631.
5. Package body is approximately 17mm x 17mm x 1.4mm, with 1.0mm ball-pitch.
6. This package code is used to reference the package diagram.

Pin Configurations^(1,2,3,8) (con't.)

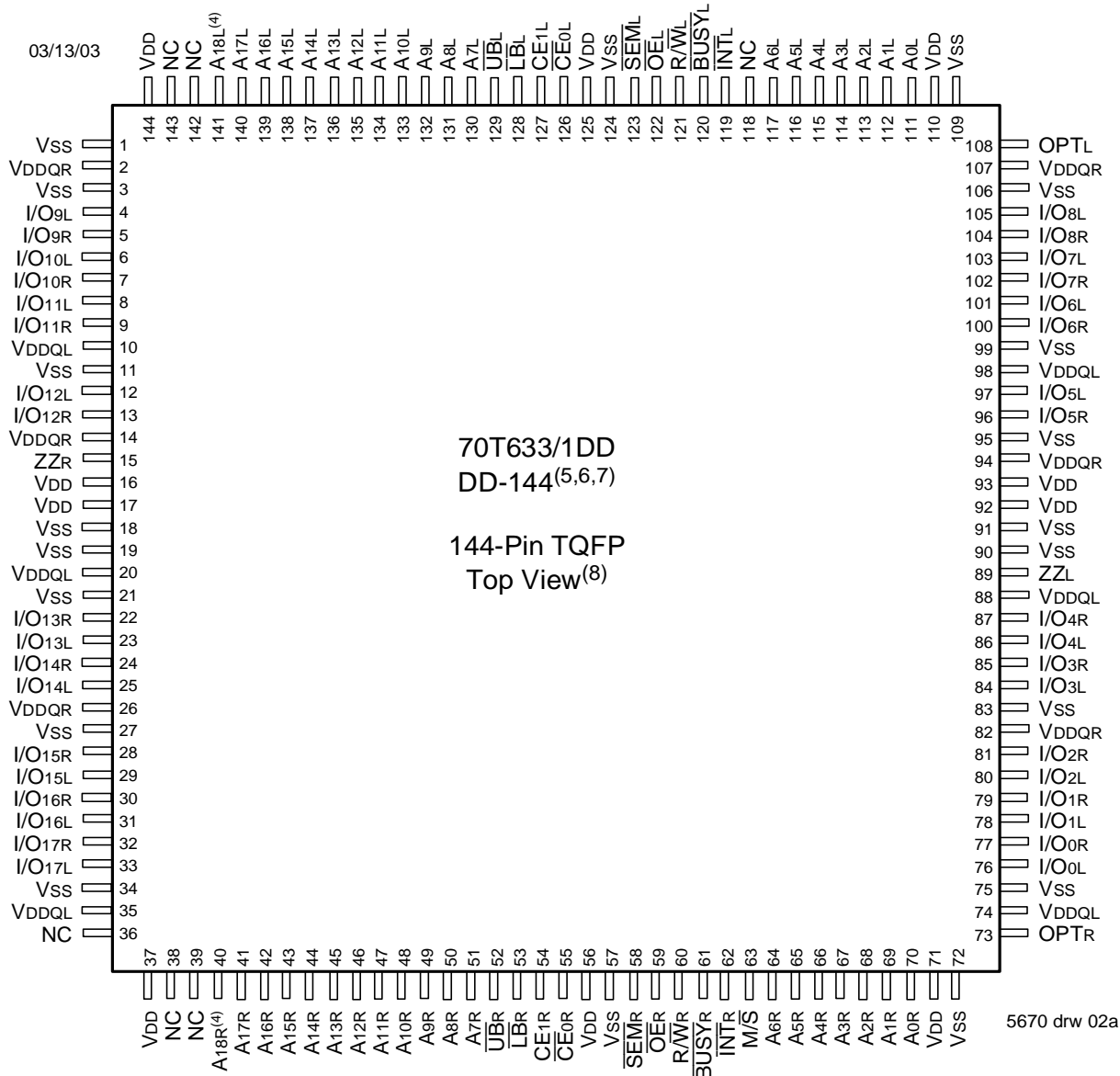

NOTES:

1. All VDD pins must be connected to 2.5V power supply.
2. All VDDQ pins must be connected to appropriate power supply: 3.3V if OPT pin for that port is set to VDD (2.5V), and 2.5V if OPT pin for that port is set to VSS (0V).
3. All VSS pins must be connected to ground.
4. A18x is a NC for IDT70T631.
5. Package body is approximately 20mm x 20mm x 1.4mm.
6. This package code is used to reference the package diagram.
7. 8ns Commercial and 10ns Industrial speed grades are not available in the DD-144 package.
8. This text does not indicate orientation of the actual part-marking.
9. Due to the restricted number of pins, JTAG is not supported in the DD-144 package.

Pin Configurations^(1,2,3)(con't.)

03/12/03

	1	2	3	4	5	6	7	8	9	10	11	12	13	14	15	16	17		
A	I/O _{9L}	NC	V _{SS}	TDO	NC	A _{16L}	A _{12L}	A _{8L}	NC	V _{DD}	$\overline{\text{SEM}}_L$	$\overline{\text{INT}}_L$	A _{4L}	A _{0L}	OPT _L	NC	V _{SS}	A	
B	NC	V _{SS}	NC	TDI	A _{17L}	A _{13L}	A _{9L}	NC	$\overline{\text{CE}}_{DL}$	V _{SS}	$\overline{\text{BUSY}}_L$	A _{5L}	A _{1L}	V _{SS}	V _{DDQR}}	I/O _{8L}	NC	B	
C	V _{DDQL}	I/O _{9R}	V _{DDQR}}	V _{DD}	A _{18L} ⁽⁴⁾	A _{14L}	A _{10L}	$\overline{\text{UB}}_L$	CE _{1L}	V _{SS}	R/ $\overline{\text{W}}_L$	A _{6L}	A _{2L}	V _{DD}	I/O _{8R}	NC	V _{SS}	C	
D	NC	V _{SS}	I/O _{10L}	NC	A _{15L}	A _{11L}	A _{7L}	$\overline{\text{LB}}_L$	V _{DD}	$\overline{\text{OE}}_L$	NC	A _{3L}	V _{DD}	NC	V _{DDQL}	I/O _{7L}	I/O _{7R}	D	
E	I/O _{11L}	NC	V _{DDQR}}	I/O _{10R}	70T633/1BF BF-208 ^(5,6) 208-Ball BGA Top View ⁽⁷⁾										I/O _{6L}	NC	V _{SS}	NC	E
F	V _{DDQL}	I/O _{11R}	NC	V _{SS}											V _{SS}	I/O _{6R}	NC	V _{DDQR}}	F
G	NC	V _{SS}	I/O _{12L}	NC											NC	V _{DDQL}	I/O _{5L}	NC	G
H	V _{DD}	NC	V _{DDQR}}	I/O _{12R}											V _{DD}	NC	V _{SS}	I/O _{5R}	H
J	V _{DDQL}	V _{DD}	V _{SS}	ZZ _R											ZZ _L	V _{DD}	V _{SS}	V _{DDQR}}	J
K	I/O _{14R}	V _{SS}	I/O _{13R}	V _{SS}											I/O _{3R}	V _{DDQL}	I/O _{4R}	V _{SS}	K
L	NC	I/O _{14L}	V _{DDQR}}	I/O _{13L}											NC	I/O _{3L}	V _{SS}	I/O _{4L}	L
M	V _{DDQL}	NC	I/O _{15R}	V _{SS}											V _{SS}	NC	I/O _{2R}	V _{DDQR}}	M
N	NC	V _{SS}	NC	I/O _{15L}											I/O _{1R}	V _{DDQL}	NC	I/O _{2L}	N
P	I/O _{16R}	I/O _{16L}	V _{DDQR}}	NC											$\overline{\text{TRST}}$	A _{16R}	A _{12R}	A _{8R}	NC
R	V _{SS}	NC	I/O _{17R}	TCK	A _{17R}	A _{13R}	A _{9R}	NC	$\overline{\text{CE}}_{DR}$	V _{SS}	$\overline{\text{BUSY}}_R$	A _{5R}	A _{1R}	V _{SS}	V _{DDQL}	I/O _{8R}	V _{DDQR}}	R	
T	NC	I/O _{17L}	V _{DDQL}	TMS	A _{18R} ⁽⁴⁾	A _{14R}	A _{10R}	$\overline{\text{UB}}_R$	CE _{1R}	V _{SS}	R/ $\overline{\text{W}}_R$	A _{6R}	A _{2R}	V _{SS}	NC	V _{SS}	NC	T	
U	V _{SS}	NC	V _{DD}	NC	A _{15R}	A _{11R}	A _{7R}	$\overline{\text{LB}}_R$	V _{DD}	$\overline{\text{OE}}_R$	M/ $\overline{\text{S}}$	A _{3R}	A _{0R}	V _{DD}	OPT _R	NC	I/O _{0L}	U	

5670 drw 02b

NOTES:

1. All V_{DD} pins must be connected to 2.5V power supply.
2. All V_{DDQ} pins must be connected to appropriate power supply: 3.3V if OPT pin for that port is set to V_{DD} (2.5V), and 2.5V if OPT pin for that port is set to V_{SS} (0V).
3. All V_{SS} pins must be connected to ground.
4. A18x is a NC for IDT70T631.
5. Package body is approximately 15mm x 15mm x 1.4mm with 0.8mm ball pitch.
6. This package code is used to reference the package diagram.
7. This text does not indicate orientation of the actual part-marking.

Pin Names

Left Port	Right Port	Names
\overline{CE}_{0L} , CE_{1L}	\overline{CE}_{0R} , CE_{1R}	Chip Enables (Input)
R/\overline{W}_L	R/\overline{W}_R	Read/Write Enable (Input)
\overline{OE}_L	\overline{OE}_R	Output Enable (Input)
$A_{0L} - A_{18L}^{(1)}$	$A_{0R} - A_{18R}^{(1)}$	Address (Input)
$I/O_{0L} - I/O_{17L}$	$I/O_{0R} - I/O_{17R}$	Data Input/Output
\overline{SEM}_L	\overline{SEM}_R	Semaphore Enable (Input)
\overline{INT}_L	\overline{INT}_R	Interrupt Flag (Output)
\overline{BUSY}_L	\overline{BUSY}_R	Busy Flag (Output)
\overline{UB}_L	\overline{UB}_R	Upper Byte Select (Input)
\overline{LB}_L	\overline{LB}_R	Lower Byte Select (Input)
V_{DDQL}	V_{DDQR}	Power (I/O Bus) (3.3V or 2.5V) ⁽²⁾ (Input)
OPT_L	OPT_R	Option for selecting $V_{DDQX}^{(2,3)}$ (Input)
ZZ_L	ZZ_R	Sleep Mode Pin ⁽⁴⁾ (Input)
M/\overline{S}		Master or Slave Select (Input) ⁽⁵⁾
V_{DD}		Power (2.5V) ⁽²⁾ (Input)
V_{SS}		Ground (0V) (Input)
TDI		Test Data Input
TDO		Test Data Output
TCK		Test Logic Clock (10MHz) (Input)
TMS		Test Mode Select (Input)
\overline{TRST}		Reset (Initialize TAP Controller) (Input)

5670 tbl 01

NOTES:

1. Address A_{18x} is a NC for IDT70T631.
2. V_{DD} , OPT_x , and V_{DDQX} must be set to appropriate operating levels prior to applying inputs on I/O_x .
3. OPT_x selects the operating voltage levels for the I/O_s and controls on that port. If OPT_x is set to V_{DD} (2.5V), then that port's I/O_s and controls will operate at 3.3V levels and V_{DDQX} must be supplied at 3.3V. If OPT_x is set to V_{SS} (0V), then that port's I/O_s and controls will operate at 2.5V levels and V_{DDQX} must be supplied at 2.5V. The OPT pins are independent of one another—both ports can operate at 3.3V levels, both can operate at 2.5V levels, or either can operate at 3.3V with the other at 2.5V.
4. The sleep mode pin shuts off all dynamic inputs, except JTAG inputs, when asserted. OPT_x , \overline{INT}_x , M/\overline{S} and the sleep mode pins themselves (ZZ_x) are not affected during sleep mode. It is recommended that boundary scan not be operated during sleep mode.
5. \overline{BUSY} is an input as a Slave ($M/\overline{S}=V_{IL}$) and an output when it is a Master ($M/\overline{S}=V_{IH}$).

Truth Table I—Read/Write and Enable Control⁽¹⁾

\overline{OE}	\overline{SEM}	\overline{CE}_0	CE_1	\overline{UB}	\overline{LB}	R/W	ZZ	Upper Byte I/O ₉₋₁₇	Lower Byte I/O ₀₋₈	MODE
X	H	H	X	X	X	X	L	High-Z	High-Z	Deselected—Power Down
X	H	X	L	X	X	X	L	High-Z	High-Z	Deselected—Power Down
X	H	L	H	H	H	X	L	High-Z	High-Z	Both Bytes Deselected
X	H	L	H	H	L	L	L	High-Z	DIN	Write to Lower Byte
X	H	L	H	L	H	L	L	DIN	High-Z	Write to Upper Byte
X	H	L	H	L	L	L	L	DIN	DIN	Write to Both Bytes
L	H	L	H	H	L	H	L	High-Z	DOUT	Read Lower Byte
L	H	L	H	L	H	H	L	DOUT	High-Z	Read Upper Byte
L	H	L	H	L	L	H	L	DOUT	DOUT	Read Both Bytes
H	H	L	H	L	L	X	L	High-Z	High-Z	Outputs Disabled
X	X	X	X	X	X	X	H	High-Z	High-Z	High-Z Sleep Mode

5670 tbl 02

NOTE:

- "H" = V_{IH} , "L" = V_{IL} , "X" = Don't Care.

Truth Table II – Semaphore Read/Write Control⁽¹⁾

Inputs ⁽¹⁾						Outputs		Mode
$\overline{CE}^{(2)}$	R/W	\overline{OE}	\overline{UB}	\overline{LB}	\overline{SEM}	I/O ₁₋₁₇	I/O ₀	
H	H	L	L	L	L	DATA _{OUT}	DATA _{OUT}	Read Data in Semaphore Flag ⁽³⁾
H	↑	X	X	L	L	X	DATA _{IN}	Write I/O ₀ into Semaphore Flag
L	X	X	X	X	L	—	—	Not Allowed

5670 tbl 03

NOTES:

- There are eight semaphore flags written to I/O₀ and read from all the I/Os (I/O₀-I/O₁₇). These eight semaphore flags are addressed by A₀-A₂.
- $\overline{CE} = L$ occurs when $\overline{CE}_0 = V_{IL}$ and $CE_1 = V_{IH}$. $\overline{CE} = H$ when $\overline{CE}_0 = V_{IH}$ and/or $CE_1 = V_{IL}$.
- Each byte is controlled by the respective \overline{UB} and \overline{LB} . To read data \overline{UB} and/or $\overline{LB} = V_{IL}$.

Recommended Operating Temperature and Supply Voltage⁽¹⁾

Grade	Ambient Temperature	GND	VDD
Commercial	0°C to +70°C	0V	2.5V ± 100mV
Industrial	-40°C to +85°C	0V	2.5V ± 100mV

5670 tbl 04

NOTE:

1. This is the parameter TA. This is the "instant on" case temperature.

Absolute Maximum Ratings⁽¹⁾

Symbol	Rating	Commercial & Industrial	Unit
VTERM (VDD)	VDD Terminal Voltage with Respect to GND	-0.5 to 3.6	V
VTERM ⁽²⁾ (VDDQ)	VDDQ Terminal Voltage with Respect to GND	-0.3 to VDDQ + 0.3	V
VTERM ⁽²⁾ (INPUTS and I/O's)	Input and I/O Terminal Voltage with Respect to GND	-0.3 to VDDQ + 0.3	V
TBIAS ⁽³⁾	Temperature Under Bias	-55 to +125	°C
TSTG	Storage Temperature	-65 to +150	°C
TJN	Junction Temperature	+150	°C
IOUT(For VDDQ = 3.3V)	DC Output Current	50	mA
IOUT(For VDDQ = 2.5V)	DC Output Current	40	mA

5670 tbl 07

NOTES:

1. Stresses greater than those listed under ABSOLUTE MAXIMUM RATINGS may cause permanent damage to the device. This is a stress rating only and functional operation of the device at these or any other conditions above those indicated in the operational sections of this specification is not implied. Exposure to absolute maximum rating conditions for extended periods may affect reliability.
2. This is a steady-state DC parameter that applies after the power supply has reached its nominal operating value. Power sequencing is not necessary; however, the voltage on any Input or I/O pin cannot exceed VDDQ during power supply ramp up.
3. Ambient Temperature under DC Bias. No AC Conditions. Chip Deselected.

Capacitance⁽¹⁾

(TA = +25°C, F = 1.0MHz) TQFP ONLY

Symbol	Parameter	Conditions ⁽²⁾	Max.	Unit
CIN	Input Capacitance	VIN = 3dV	8	pF
COU ⁽³⁾	Output Capacitance	VOUT = 3dV	10.5	pF

5670 tbl 08

NOTES:

1. These parameters are determined by device characterization, but are not production tested.
2. 3dV references the interpolated capacitance when the input and output switch from 0V to 3V or from 3V to 0V.
3. COU also references CIO.

Recommended DC Operating Conditions with VDDQ at 2.5V

Symbol	Parameter	Min.	Typ.	Max.	Unit
VDD	Core Supply Voltage	2.4	2.5	2.6	V
VDDQ	I/O Supply Voltage ⁽³⁾	2.4	2.5	2.6	V
VSS	Ground	0	0	0	V
VIH	Input High Voltage (Address, Control & Data I/O Inputs) ⁽³⁾	1.7	—	VDDQ + 100mV ⁽²⁾	V
VIH	Input High Voltage - JTAG	1.7	—	VDD + 100mV ⁽²⁾	V
VIH	Input High Voltage - ZZ, OPT, M/S	VDD - 0.2V	—	VDD + 100mV ⁽²⁾	V
VIL	Input Low Voltage	-0.3 ⁽¹⁾	—	0.7	V
VIL	Input Low Voltage - ZZ, OPT, M/S	-0.3 ⁽¹⁾	—	0.2	V

5670 tbl 05

NOTES:

1. VIL (min.) = -1.0V for pulse width less than trc/2 or 5ns, whichever is less.
2. VIH (max.) = VDDQ + 1.0V for pulse width less than trc/2 or 5ns, whichever is less.
3. To select operation at 2.5V levels on the I/Os and controls of a given port, the OPT pin for that port must be set to VSS (0V), and VDDQx for that port must be supplied as indicated above.

Recommended DC Operating Conditions with VDDQ at 3.3V

Symbol	Parameter	Min.	Typ.	Max.	Unit
VDD	Core Supply Voltage	2.4	2.5	2.6	V
VDDQ	I/O Supply Voltage ⁽³⁾	3.15	3.3	3.45	V
VSS	Ground	0	0	0	V
VIH	Input High Voltage (Address, Control & Data I/O Inputs) ⁽³⁾	2.0	—	VDDQ + 150mV ⁽²⁾	V
VIH	Input High Voltage - JTAG	1.7	—	VDD + 100mV ⁽²⁾	V
VIH	Input High Voltage - ZZ, OPT, M/S	VDD - 0.2V	—	VDD + 100mV ⁽²⁾	V
VIL	Input Low Voltage	-0.3 ⁽¹⁾	—	0.8	V
VIL	Input Low Voltage - ZZ, OPT, M/S	-0.3 ⁽¹⁾	—	0.2	V

5670 tbl 06

NOTES:

1. VIL (min.) = -1.0V for pulse width less than trc/2 or 5ns, whichever is less.
2. VIH (max.) = VDDQ + 1.0V for pulse width less than trc/2 or 5ns, whichever is less.
3. To select operation at 3.3V levels on the I/Os and controls of a given port, the OPT pin for that port must be set to VDD (2.5V), and VDDQx for that port must be supplied as indicated above.

DC Electrical Characteristics Over the Operating Temperature and Supply Voltage Range (V_{DD} = 2.5V ± 100mV)

Symbol	Parameter	Test Conditions	70T633/1S		Unit
			Min.	Max.	
I _L	Input Leakage Current ⁽¹⁾	V _{DDQ} = Max., V _{IN} = 0V to V _{DDQ}	—	10	μA
I _L	JTAG & ZZ Input Leakage Current ^(1,2)	V _{DD} = Max., V _{IN} = 0V to V _{DD}	—	±30	μA
I _{LO}	Output Leakage Current ^(1,3)	$\overline{CE}_0 = V_{IH}$ or $CE_1 = V_{IL}$, V _{OUT} = 0V to V _{DDQ}	—	10	μA
V _{OL} (3.3V)	Output Low Voltage ⁽¹⁾	I _{OL} = +4mA, V _{DDQ} = Min.	—	0.4	V
V _{OH} (3.3V)	Output High Voltage ⁽¹⁾	I _{OH} = -4mA, V _{DDQ} = Min.	2.4	—	V
V _{OL} (2.5V)	Output Low Voltage ⁽¹⁾	I _{OL} = +2mA, V _{DDQ} = Min.	—	0.4	V
V _{OH} (2.5V)	Output High Voltage ⁽¹⁾	I _{OH} = -2mA, V _{DDQ} = Min.	2.0	—	V

NOTES:

- V_{DDQ} is selectable (3.3V/2.5V) via OPT pins. Refer to page 6 for details.
- Applicable only for TMS, TDI and TRST inputs.
- Outputs tested in tri-state mode.

5670 tbl 09

DC Electrical Characteristics Over the Operating Temperature and Supply Voltage Range (V_{DD} = 2.5V ± 100mV)

Symbol	Parameter	Test Condition	Version	70T633/1S8 ⁽⁶⁾ Com'l Only		70T633/1S10 Com'l & Ind ⁽⁶⁾		70T633/1S12 Com'l & Ind		70T633/1S15 Com'l Only		Unit
				Typ. ⁽⁴⁾	Max.	Typ. ⁽⁴⁾	Max.	Typ. ⁽⁴⁾	Max.	Typ. ⁽⁴⁾	Max.	
IDD	Dynamic Operating Current (Both Ports Active)	\overline{CE}_L and $\overline{CE}_R = V_{IL}$, Outputs Disabled f = f _{MAX} ⁽¹⁾	COM'L S	350	475	300	405	300	355	225	305	mA
			IND S	—	—	300	445	300	395	—	—	
ISB1 ⁽⁶⁾	Standby Current (Both Ports - TTL Level Inputs)	$\overline{CE}_L = \overline{CE}_R = V_{IH}$ f = f _{MAX} ⁽¹⁾	COM'L S	115	140	90	120	75	105	60	85	mA
			IND S	—	—	90	145	75	130	—	—	
ISB2 ⁽⁶⁾	Standby Current (One Port - TTL Level Inputs)	$\overline{CE}^*A^* = V_{IL}$ and $\overline{CE}^*B^* = V_{IH}$ ⁽⁵⁾ Active Port Outputs Disabled, f = f _{MAX} ⁽¹⁾	COM'L S	240	315	200	265	180	230	150	200	mA
			IND S	—	—	200	290	180	255	—	—	
ISB3	Full Standby Current (Both Ports - CMOS Level Inputs)	Both Ports \overline{CE}_L and $\overline{CE}_R \geq V_{DD} - 0.2V$, V _{IN} ≥ V _{DD} - 0.2V or V _{IN} ≤ 0.2V, f = 0 ⁽²⁾	COM'L S	2	10	2	10	2	10	2	10	mA
			IND S	—	—	2	20	2	20	—	—	
ISB4 ⁽⁶⁾	Full Standby Current (One Port - CMOS Level Inputs)	$\overline{CE}^*A^* \leq 0.2V$ and $\overline{CE}^*B^* \geq V_{DD} - 0.2V$ ⁽⁵⁾ V _{IN} ≥ V _{DD} - 0.2V or V _{IN} ≤ 0.2V, Active Port, Outputs Disabled, f = f _{MAX} ⁽¹⁾	COM'L S	240	315	200	265	180	230	150	200	mA
			IND S	—	—	200	290	180	255	—	—	
IZZ	Sleep Mode Current (Both Ports - TTL Level Inputs)	ZZL = ZZR = V _{IH} f = f _{MAX} ⁽¹⁾	COM'L S	2	10	2	10	2	10	2	10	mA
			IND S	—	—	2	20	2	20	—	—	

NOTES:

- At f = f_{MAX}, address and control lines (except Output Enable) are cycling at the maximum frequency read cycle of 1/trc, using "AC TEST CONDITIONS".
- f = 0 means no address or control lines change. Applies only to input at CMOS level standby.
- V_{DD} = 2.5V, T_A = 25°C for Typ. values, and are not production tested. I_{DD} dc(f=0) = 100mA (Typ).
- $\overline{CE}_X = V_{IL}$ means $\overline{CE}_{0X} = V_{IL}$ and $CE_{1X} = V_{IH}$
 $\overline{CE}_X = V_{IH}$ means $\overline{CE}_{0X} = V_{IH}$ or $CE_{1X} = V_{IL}$
 $\overline{CE}_X \leq 0.2V$ means $\overline{CE}_{0X} \leq 0.2V$ and $CE_{1X} \geq V_{DDQX} - 0.2V$
 $\overline{CE}_X \geq V_{DDQX} - 0.2V$ means $\overline{CE}_{0X} \geq V_{DDQX} - 0.2V$ or $CE_{1X} = 0.2V$
 "X" represents "L" for left port or "R" for right port.
- ISB1, ISB2 and ISB4 will all reach full standby levels (ISB3) on the appropriate port(s) if ZZL and/or ZZR = V_{IH}.
- 8ns Commercial and 10ns Industrial speed grades are available in BF-208 and BC-256 packages only.

5670 tbl 10

AC Test Conditions (V_{DDQ} = 3.3V/2.5V)

Input Pulse Levels	GND to 3.0V / GND to 2.5V
Input Rise/Fall Times	2ns Max.
Input Timing Reference Levels	1.5V/1.25V
Output Reference Levels	1.5V/1.25V
Output Load	Figure 1

5670 tbl 11

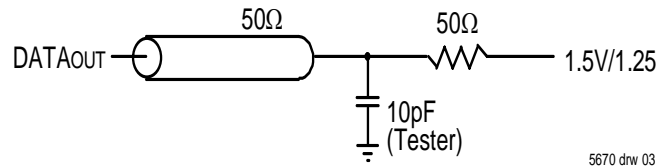

5670 drw 03

Figure 1. AC Output Test load.

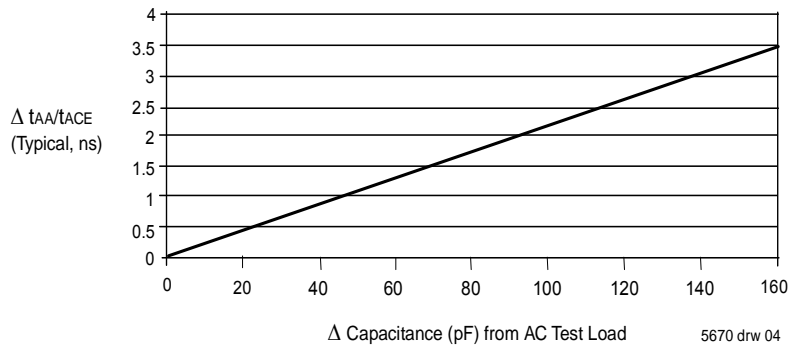

5670 drw 04

Figure 3. Typical Output Derating (Lumped Capacitive Load).

AC Electrical Characteristics Over the Operating Temperature and Supply Voltage Range⁽⁴⁾

Symbol	Parameter	70T633/1S8 ⁽⁵⁾ Com'l Only		70T633/1S10 Com'l & Ind ⁽⁵⁾		70T633/1S12 Com'l & Ind		70T633/1S15 Com'l Only		Unit
		Min.	Max.	Min.	Max.	Min.	Max.	Min.	Max.	
READ CYCLE										
t _{RC}	Read Cycle Time	8	—	10	—	12	—	15	—	ns
t _{AA}	Address Access Time	—	8	—	10	—	12	—	15	ns
t _{ACE}	Chip Enable Access Time ⁽³⁾	—	8	—	10	—	12	—	15	ns
t _{ABE}	Byte Enable Access Time ⁽³⁾	—	4	—	5	—	6	—	7	ns
t _{AOE}	Output Enable Access Time	—	4	—	5	—	6	—	7	ns
t _{OH}	Output Hold from Address Change	3	—	3	—	3	—	3	—	ns
t _{LZ}	Output Low-Z Time Chip Enable and Semaphore ^(1,2)	3	—	3	—	3	—	3	—	ns
t _{LZOB}	Output Low-Z Time Output Enable and Byte Enable ^(1,2)	0	—	0	—	0	—	0	—	ns
t _{HZ}	Output High-Z Time ^(1,2)	0	3.5	0	4	0	6	0	8	ns
t _{PU}	Chip Enable to Power Up Time ⁽²⁾	0	—	0	—	0	—	0	—	ns
t _{PD}	Chip Disable to Power Down Time ⁽²⁾	—	7	—	8	—	8	—	12	ns
t _{SOP}	Semaphore Flag Update Pulse (\overline{OE} or \overline{SEM})	—	4	—	4	—	6	—	8	ns
t _{SAA}	Semaphore Address Access Time	2	8	2	10	2	12	2	15	ns
t _{SOE}	Semaphore Output Enable Access Time	—	5	—	5	—	6	—	7	ns

5670 tbl 12

AC Electrical Characteristics Over the Operating Temperature and Supply Voltage⁽⁴⁾

Symbol	Parameter	70T633/1S8 ⁽⁵⁾ Com'l Only		70T633/1S10 Com'l & Ind ⁽⁵⁾		70T633/1S12 Com'l & Ind		70T633/1S15 Com'l Only		Unit
		Min.	Max.	Min.	Max.	Min.	Max.	Min.	Max.	
WRITE CYCLE										
t _{WC}	Write Cycle Time	8	—	10	—	12	—	15	—	ns
t _{EW}	Chip Enable to End-of-Write ⁽³⁾	6	—	7	—	9	—	12	—	ns
t _{AW}	Address Valid to End-of-Write	6	—	7	—	9	—	12	—	ns
t _{AS}	Address Set-up Time ⁽³⁾	0	—	0	—	0	—	0	—	ns
t _{WP}	Write Pulse Width	6	—	7	—	9	—	12	—	ns
t _{WR}	Write Recovery Time	0	—	0	—	0	—	0	—	ns
t _{DW}	Data Valid to End-of-Write	4	—	5	—	7	—	10	—	ns
t _{DH}	Data Hold Time	0	—	0	—	0	—	0	—	ns
t _{WZ}	Write Enable to Output in High-Z ^(1,2)	—	3.5	—	4	—	6	—	8	ns
t _{OW}	Output Active from End-of-Write ^(1,2)	3	—	3	—	3	—	3	—	ns
t _{SWRD}	\overline{SEM} Flag Write to Read Time	4	—	5	—	5	—	5	—	ns
t _{SPS}	\overline{SEM} Flag Contention Window	4	—	5	—	5	—	5	—	ns

5670 tbl 13

NOTES:

1. Transition is measured 0mV from Low or High-impedance voltage with Output Test Load (Figure 1).
2. This parameter is guaranteed by device characterization, but is not production tested.
3. To access RAM, $\overline{CE} = V_{IL}$ and $\overline{SEM} = V_{IH}$. To access semaphore, $\overline{CE} = V_{IH}$ and $\overline{SEM} = V_{IL}$. Either condition must be valid for the entire t_{EW} time. $\overline{CE} = V_{IL}$ when $\overline{CE}_0 = V_{IL}$ and $\overline{CE}_1 = V_{IH}$. $\overline{CE} = V_{IH}$ when $\overline{CE}_0 = V_{IH}$ and/or $\overline{CE}_1 = V_{IL}$.
4. These values are valid regardless of the power supply level selected for I/O and control signals (3.3V/2.5V). See page 6 for details.
5. 8ns Commercial and 10ns Industrial speed grades are available in BF-208 and BC-256 packages only.

Waveform of Read Cycles⁽⁵⁾

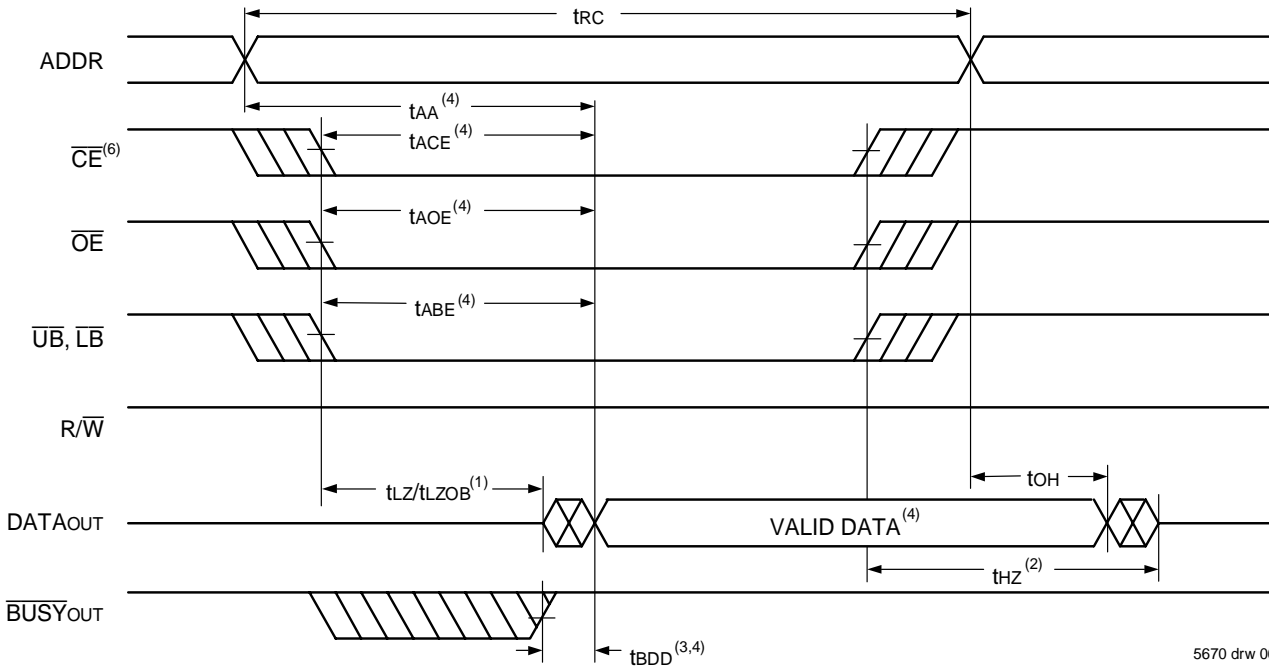

5670 drw 06

NOTES:

1. Timing depends on which signal is asserted last, \overline{OE} , \overline{CE} , \overline{LB} or \overline{UB} .
2. Timing depends on which signal is de-asserted first \overline{CE} , \overline{OE} , \overline{LB} or \overline{UB} .
3. t_{BDD} delay is required only in cases where the opposite port is completing a write operation to the same address location. For simultaneous read operations \overline{BUSY} has no relation to valid output data.
4. Start of valid data depends on which timing becomes effective last: t_{AOE} , t_{ACE} , t_{AA} , t_{ABE} , or t_{BDD} .
5. $\overline{SEM} = V_{IH}$.
6. $\overline{CE} = L$ occurs when $\overline{CE}_0 = V_{IL}$ and $CE_1 = V_{IH}$. $\overline{CE} = H$ when $\overline{CE}_0 = V_{IH}$ and/or $CE_1 = V_{IL}$.

Timing of Power-Up Power-Down

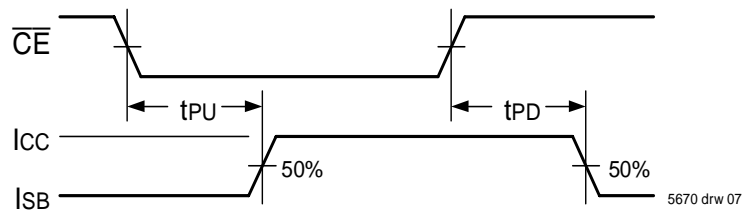

5670 drw 07

Timing Waveform of Write Cycle No. 1, R/\bar{W} Controlled Timing^(1,5,8)

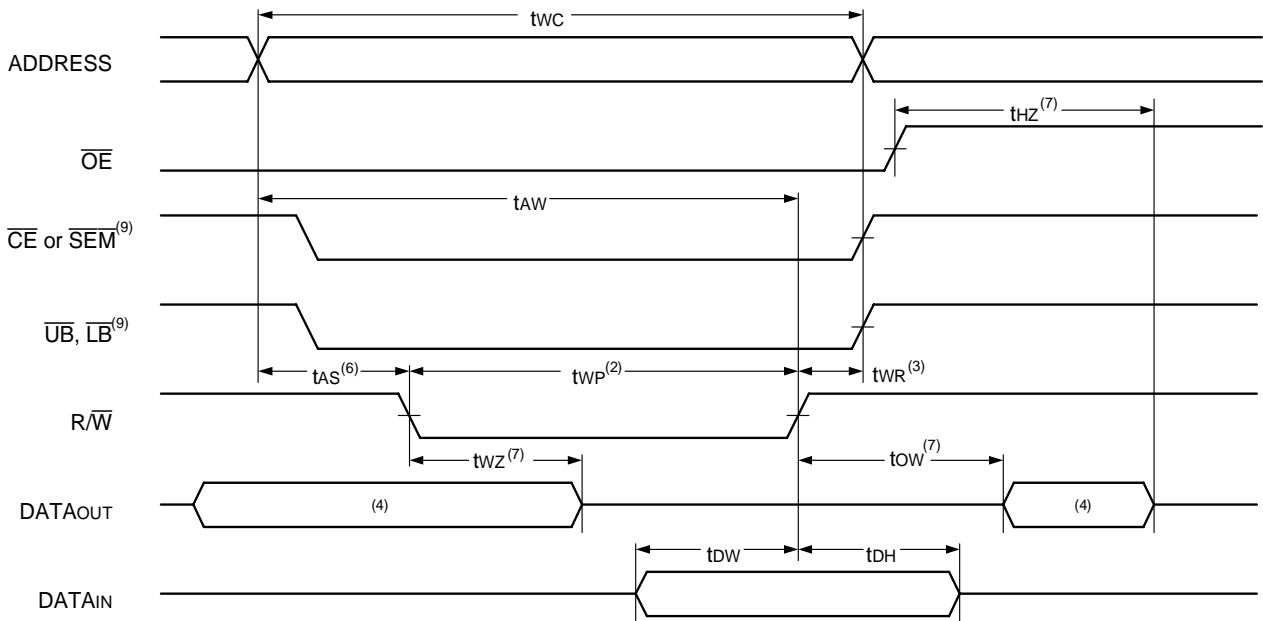

5670 drw 10

Timing Waveform of Write Cycle No. 2, \bar{CE} Controlled Timing^(1,5,8)

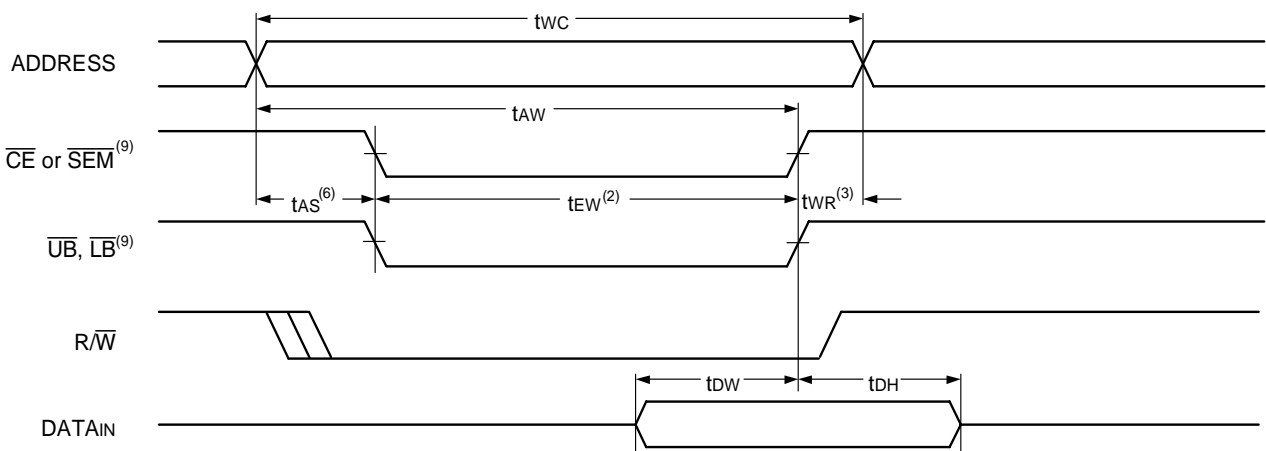

5670 drw 11

NOTES:

1. R/\bar{W} or \bar{CE} or \bar{UB} or $\bar{LB} = V_{IH}$ during all address transitions.
2. A write occurs during the overlap (t_{EW} or t_{WP}) of a $\bar{CE} = V_{IL}$ and a $R/\bar{W} = V_{IL}$ for memory array writing cycle.
3. t_{WR} is measured from the earlier of \bar{CE} or R/\bar{W} (or \bar{SEM} or R/\bar{W}) going HIGH to the end of write cycle.
4. During this period, the I/O pins are in the output state and input signals must not be applied.
5. If the \bar{CE} or $\bar{SEM} = V_{IL}$ transition occurs simultaneously with or after the $R/\bar{W} = V_{IL}$ transition, the outputs remain in the High-impedance state.
6. Timing depends on which enable signal is asserted last, \bar{CE} or R/\bar{W} .
7. This parameter is guaranteed by device characterization, but is not production tested. Transition is measured 0mV from steady state with the Output Test Load (Figure 1).
8. If $\bar{OE} = V_{IL}$ during R/\bar{W} controlled write cycle, the write pulse width must be the larger of t_{WP} or $(t_{WZ} + t_{DW})$ to allow the I/O drivers to turn off and data to be placed on the bus for the required t_{DW} . If $\bar{OE} = V_{IH}$ during an R/\bar{W} controlled write cycle, this requirement does not apply and the write pulse can be as short as the specified t_{WP} .
9. To access RAM, $\bar{CE} = V_{IL}$ and $\bar{SEM} = V_{IH}$. To access semaphore, $\bar{CE} = V_{IH}$ and $\bar{SEM} = V_{IL}$. t_{EW} must be met for either condition. $\bar{CE} = V_{IL}$ when $\bar{CE}_0 = V_{IL}$ and $CE_1 = V_{IH}$. $\bar{CE} = V_{IH}$ when $\bar{CE}_0 = V_{IH}$ and/or $CE_1 = V_{IL}$.

RapidWrite Mode Write Cycle

Unlike other vendors' Asynchronous Random Access Memories, the IDT70T651/9 is capable of performing multiple back-to-back write operations without having to pulse the $\overline{R/\overline{W}}$, \overline{CE} , or \overline{BEn} signals high during address transitions. This RapidWrite Mode functionality allows the system designer to achieve optimum back-to-back write cycle performance without the difficult task of generating narrow reset pulses every cycle, simplifying system design and reducing time to market.

During this new RapidWrite Mode, the end of the write cycle is now defined by the ending address transition, instead of the $\overline{R/\overline{W}}$ or \overline{CE} or \overline{BEn} transition to the inactive state. $\overline{R/\overline{W}}$, \overline{CE} , and \overline{BEn} can be held active throughout the address transition between write cycles.

Care must be taken to still meet the Write Cycle time (t_{WC}), the time in which the Address inputs must be stable. Input data setup and hold times (t_{DW} and t_{DH}) will now be referenced to the ending address transition. In this RapidWrite Mode the I/O will remain in the Input mode for the duration of the operations due to $\overline{R/\overline{W}}$ being held low. All standard Write Cycle specifications must be adhered to. However, t_{AS} and t_{WR} are only applicable when switching between read and write operations. Also, there are two additional conditions on the Address Inputs that must also be met to ensure correct address controlled writes. These specifications, the Allowable Address Skew (t_{AAS}) and the Address Rise/Fall time (t_{ARF}), must be met to use the RapidWrite Mode. If these conditions are not met there is the potential for inadvertent write operations at random intermediate locations as the device transitions between the desired write addresses.

Timing Waveform of Write Cycle No. 3, RapidWrite Mode Write Cycle^(1,3)

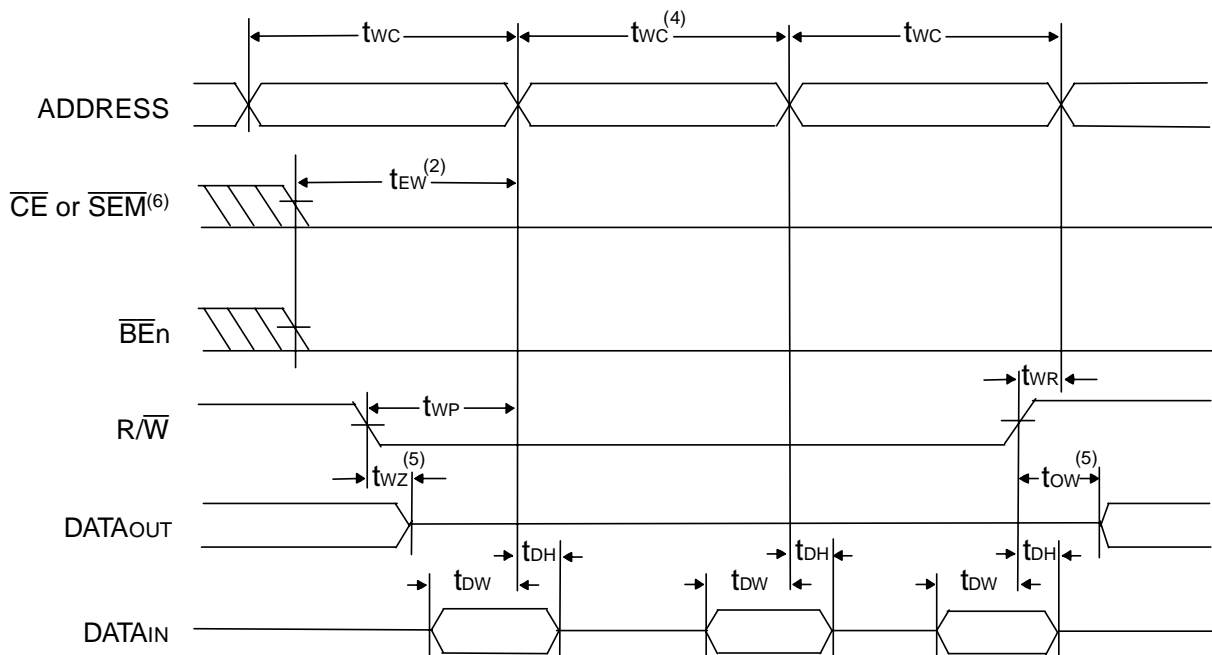

5670 drw 08

NOTES:

- $\overline{OE} = V_{IL}$ for this timing waveform as shown. \overline{OE} may equal V_{IH} with same write functionality; I/O would then always be in High-Z state.
- A write occurs during the overlap (t_{EW} or t_{WP}) of a $\overline{CE} = V_{IL}$, $\overline{BEn} = V_{IL}$, and a $\overline{R/\overline{W}} = V_{IL}$ for memory array writing cycle. The last transition LOW of \overline{CE} , \overline{BEn} , and $\overline{R/\overline{W}}$ initiates the write sequence. The first transition HIGH of \overline{CE} , \overline{BEn} , and $\overline{R/\overline{W}}$ terminates the write sequence.
- If the \overline{CE} or $\overline{SEM} = V_{IL}$ transition occurs simultaneously with or after the $\overline{R/\overline{W}} = V_{IL}$ transition, the outputs remain in the High-impedance state.
- The timing represented in this cycle can be repeated multiple times to execute sequential RapidWrite Mode writes.
- This parameter is guaranteed by device characterization, but is not production tested. Transition is measured 0mV from steady state with the Output Test Load (Figure 1).
- To access RAM, $\overline{CE} = V_{IL}$ and $\overline{SEM} = V_{IH}$. To access semaphore, $\overline{CE} = V_{IH}$ and $\overline{SEM} = V_{IL}$. t_{EW} must be met for either condition. $\overline{CE} = V_{IL}$ when $\overline{CE0} = V_{IL}$ and $CE1 = V_{IH}$. $\overline{CE} = V_{IH}$ when $\overline{CE0} = V_{IH}$ and/or $CE1 = V_{IL}$.

AC Electrical Characteristics over the Operating Temperature Range and Supply Voltage Range for RapidWrite Mode Write Cycle⁽¹⁾

Symbol	Parameter	Min	Max	Unit
t_{AAS}	Allowable Address Skew for RapidWrite Mode	—	1	ns
t_{ARF}	Address Rise/Fall Time for RapidWrite Mode	1.5	—	V/ns

5670 tbl 14

NOTE:

1. Timing applies to all speed grades when utilizing the RapidWrite Mode Write Cycle.

Timing Waveform of Address Inputs for RapidWrite Mode Write Cycle

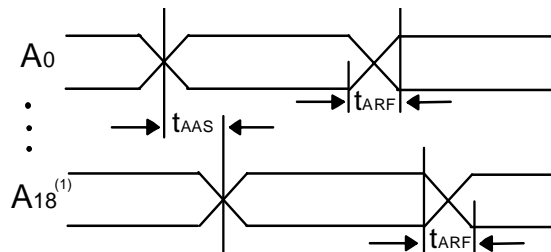

5670 drw 09

NOTE:

1. A₁₇ for IDT70T631.

Timing Waveform of Semaphore Read after Write Timing, Either Side⁽¹⁾

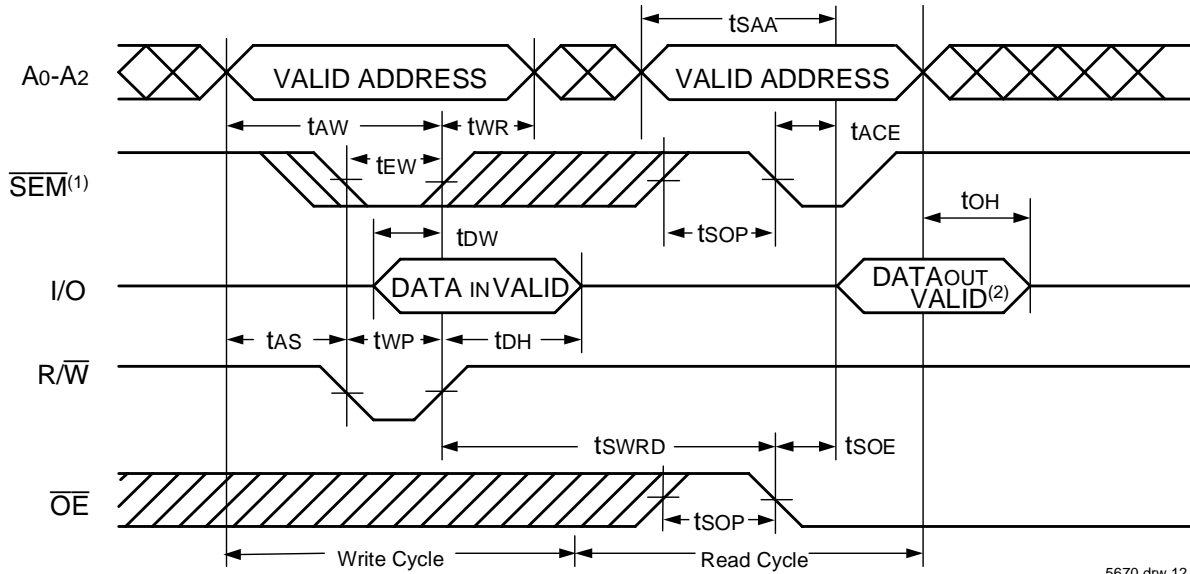

5670 drw 12

NOTES:

- $\overline{CE}_0 = V_{IH}$ and $CE_1 = V_{IL}$ are required for the duration of both the write cycle and the read cycle waveforms shown above. Refer to Truth Table II for details and for appropriate $\overline{UB}/\overline{LB}$ controls.
- "DATA OUT VALID" represents all I/O's (I/O₀ - I/O₁₇) equal to the semaphore value.

Timing Waveform of Semaphore Write Contention^(1,3,4)

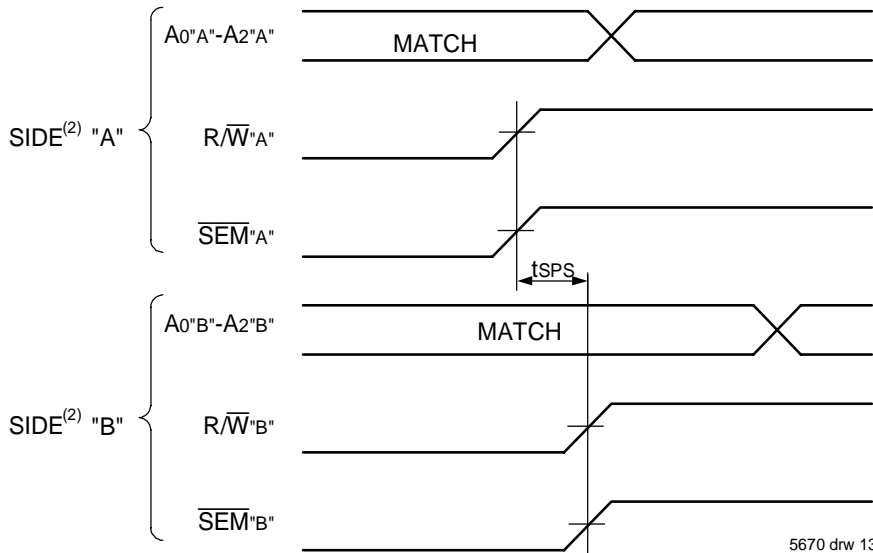

5670 drw 13

NOTES:

- $D_{OR} = D_{OL} = V_{IL}$, $\overline{CE}_{0L} = \overline{CE}_{0R} = V_{IH}$; $CE_{1L} = CE_{1R} = V_{IL}$. Refer also to Truth Table II for appropriate $\overline{UB}/\overline{LB}$ controls.
- All timing is the same for left and right ports. Port "A" may be either left or right port. "B" is the opposite from port "A".
- This parameter is measured from R/\overline{W}^A or \overline{SEM}^A going HIGH to R/\overline{W}^B or \overline{SEM}^B going HIGH.
- If t_{SPS} is not satisfied, the semaphore will fall positively to one side or the other, but there is no guarantee which side will be granted the semaphore flag.

AC Electrical Characteristics Over the Operating Temperature and Supply Voltage Range

Symbol	Parameter	70T633/1S8 ⁽⁶⁾ Com'l Only		70T633/1S10 Com'l & Ind ⁽⁶⁾		70T633/1S12 Com'l & Ind		70T633/1S15 Com'l Only		Unit
		Min.	Max.	Min.	Max.	Min.	Max.	Min.	Max.	
BUSY TIMING ($M/\bar{S}=V_{IH}$)										
t _{BAA}	\overline{BUSY} Access Time from Address Match	—	8	—	10	—	12	—	15	ns
t _{BDA}	\overline{BUSY} Disable Time from Address Not Matched	—	8	—	10	—	12	—	15	ns
t _{BAC}	\overline{BUSY} Access Time from Chip Enable Low	—	8	—	10	—	12	—	15	ns
t _{BDC}	\overline{BUSY} Disable Time from Chip Enable High	—	8	—	10	—	12	—	15	ns
t _{APS}	Arbitration Priority Set-up Time ⁽²⁾	2.5	—	2.5	—	2.5	—	2.5	—	ns
t _{BDD}	\overline{BUSY} Disable to Valid Data ⁽³⁾	—	8	—	10	—	12	—	15	ns
t _{WH}	Write Hold After \overline{BUSY} ⁽⁵⁾	6	—	7	—	9	—	12	—	ns
BUSY TIMING ($M/\bar{S}=V_{IL}$)										
t _{WB}	\overline{BUSY} Input to Write ⁽⁴⁾	0	—	0	—	0	—	0	—	ns
t _{WH}	Write Hold After \overline{BUSY} ⁽⁵⁾	6	—	7	—	9	—	12	—	ns
PORT-TO-PORT DELAY TIMING										
t _{WDD}	Write Pulse to Data Delay ⁽¹⁾	—	12	—	14	—	16	—	20	ns
t _{DDD}	Write Data Valid to Read Data Delay ⁽¹⁾	—	12	—	14	—	16	—	20	ns

5670 tbl 15

NOTES:

- Port-to-port delay through RAM cells from writing port to reading port, refer to "Timing Waveform of Write with Port-to-Port Read and \overline{BUSY} ($M/\bar{S} = V_{IH}$)".
- To ensure that the earlier of the two ports wins.
- t_{BDD} is a calculated parameter and is the greater of the Max. spec, t_{WDD} – t_{WP} (actual), or t_{DDD} – t_{DW} (actual).
- To ensure that the write cycle is inhibited on port "B" during contention on port "A".
- To ensure that a write cycle is completed on port "B" after contention on port "A".
- 8ns Commercial and 10ns Industrial speed grades are available in BF-208 and BC-256 packages only.

AC Electrical Characteristics Over the Operating Temperature and Supply Voltage Range^(1,2,3)

Symbol	Parameter	70T633/1S8 ⁽⁴⁾ Com'l Only		70T633/1S10 Com'l & Ind ⁽⁴⁾		70T633/1S12 Com'l & Ind		70T633/1S15 Com'l Only		
		Min.	Max.	Min.	Max.	Min.	Max.	Min.	Max.	
SLEEP MODE TIMING ($ZZx=V_{IH}$)										
t _{ZZS}	Sleep Mode Set Time	8	—	10	—	12	—	15	—	
t _{ZZR}	Sleep Mode Reset Time	8	—	10	—	12	—	15	—	
t _{ZZPD}	Sleep Mode Power Down Time ⁽⁵⁾	8	—	10	—	12	—	15	—	
t _{ZZPU}	Sleep Mode Power Up Time ⁽⁵⁾	—	0	—	0	—	0	—	0	

5670 tbl 15a

NOTES:

- Timing is the same for both ports.
- The sleep mode pin shuts off all dynamic inputs, except JTAG inputs, when asserted. OPTx, \overline{INTx} , M/\bar{S} and the sleep mode pins themselves (ZZx) are not affected during sleep mode. It is recommended that boundary scan not be operated during sleep mode.
- These values are valid regardless of the power supply level selected for I/O and control signals (3.3V/2.5V). See page 6 for details.
- 8ns Commercial and 10ns Industrial speed grades are available in BF-208 and BC-256 packages only.
- This parameter is guaranteed by device characterization, but is not production tested.

Timing Waveform of Write with Port-to-Port Read and \overline{BUSY} ($M/\overline{S} = V_{IH}$)^(2,4,5)

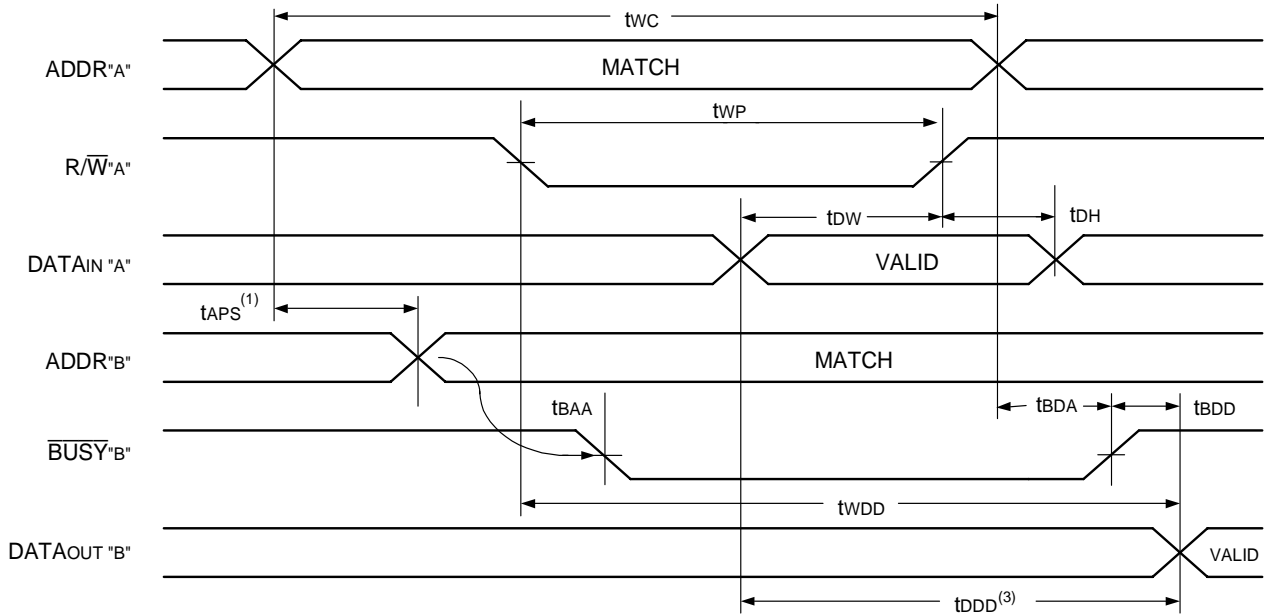

NOTES:

1. To ensure that the earlier of the two ports wins. t_{APS} is ignored for $M/\overline{S} = V_{IL}$ (SLAVE).
2. $\overline{CE}_{0L} = \overline{CE}_{0R} = V_{IL}$; $CE_{1L} = CE_{1R} = V_{IH}$.
3. $\overline{OE} = V_{IL}$ for the reading port.
4. If $M/\overline{S} = V_{IL}$ (slave), \overline{BUSY} is an input. Then for this example $\overline{BUSY}'_A = V_{IH}$ and \overline{BUSY}'_B input is shown above.
5. All timing is the same for left and right ports. Port "A" may be either the left or right port. Port "B" is the port opposite from port "A".

5670 drw 14

Timing Waveform of Write with \overline{BUSY} ($M/\overline{S} = V_{IL}$)

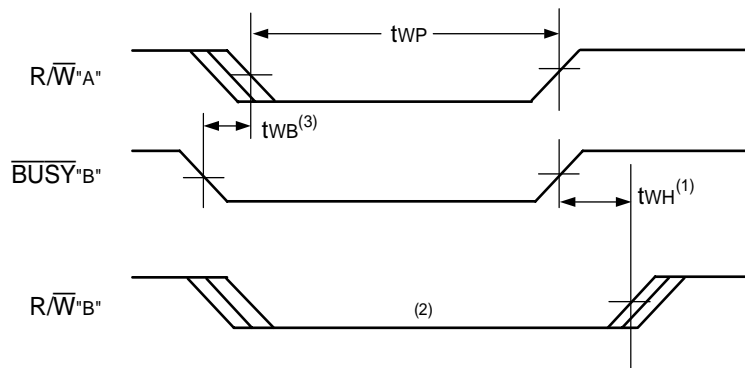

NOTES:

1. t_{WH} must be met for both \overline{BUSY} input (SLAVE) and output (MASTER).
2. \overline{BUSY} is asserted on port "B" blocking R/\overline{W}'_B , until \overline{BUSY}'_B goes HIGH.
3. t_{WB} only applies to the slave mode.

5670 drw 15

Waveform of $\overline{\text{BUSY}}$ Arbitration Controlled by $\overline{\text{CE}}$ Timing ($M/\overline{\text{S}} = V_{IH}$)⁽¹⁾

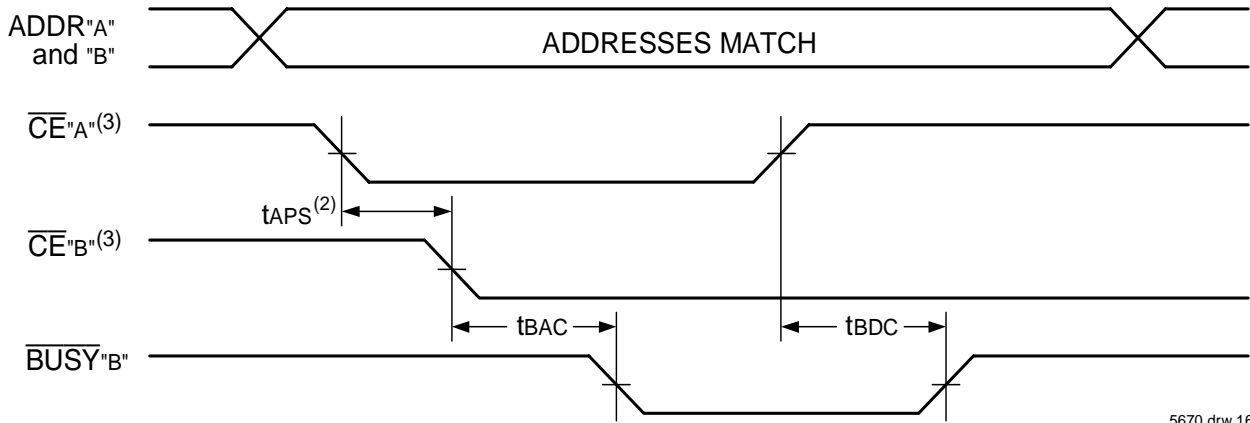

5670 drw 16

Waveform of $\overline{\text{BUSY}}$ Arbitration Cycle Controlled by Address Match Timing ($M/\overline{\text{S}} = V_{IH}$)^(1,3,4)

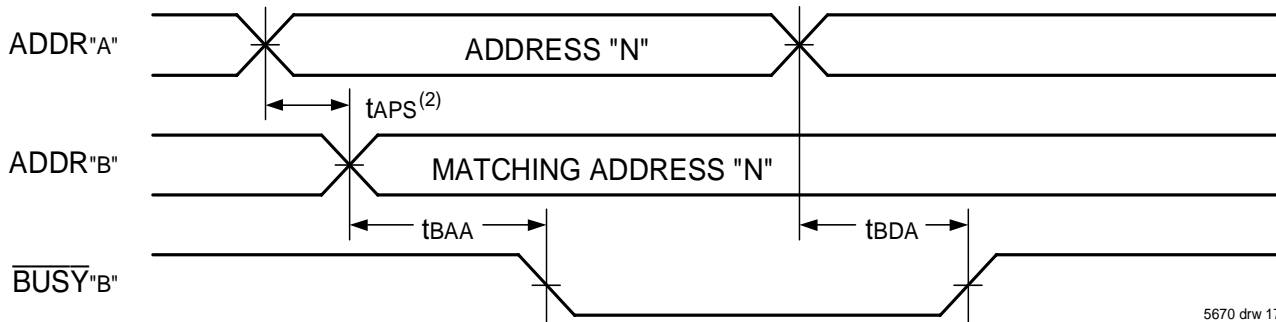

5670 drw 17

NOTES:

1. All timing is the same for left and right ports. Port "A" may be either the left or right port. Port "B" is the port opposite from port "A".
2. If tAPS is not satisfied, the $\overline{\text{BUSY}}$ signal will be asserted on one side or another but there is no guarantee on which side $\overline{\text{BUSY}}$ will be asserted.
3. $\overline{\text{CE}}_X = V_{IL}$ when $\overline{\text{CE}}_{0X} = V_{IL}$ and $\text{CE}_{1X} = V_{IH}$. $\overline{\text{CE}}_X = V_{IH}$ when $\overline{\text{CE}}_{0X} = V_{IH}$ and/or $\text{CE}_{1X} = V_{IL}$.
4. $\overline{\text{CE}}_{0X} = \overline{\text{OE}}_X = \overline{\text{LB}}_X = \overline{\text{UB}}_X = V_{IL}$. $\text{CE}_{1X} = V_{IH}$.

AC Electrical Characteristics Over the Operating Temperature and Supply Voltage Range^(1,2)

Symbol	Parameter	70T633/1S8 ⁽³⁾ Com'l Only		70T633/1S10 Com'l & Ind ⁽³⁾		70T633/1S12 Com'l & Ind		70T633/1S15 Com'l Only		Unit
		Min.	Max.	Min.	Max.	Min.	Max.	Min.	Max.	
INTERRUPT TIMING										
tAS	Address Set-up Time	0	—	0	—	0	—	0	—	ns
tWR	Write Recovery Time	0	—	0	—	0	—	0	—	ns
tNS	Interrupt Set Time	—	8	—	10	—	12	—	15	ns
tNR	Interrupt Reset Time	—	8	—	10	—	12	—	15	ns

5670 tbl 16

NOTES:

1. Timing is the same for both ports.
2. These values are valid regardless of the power supply level selected for I/O and control signals (3.3V/2.5V). See page 6 for details.
3. 8ns Commercial and 10ns Industrial speed grades are available in BF-208 and BC-256 packages only.

Waveform of Interrupt Timing⁽¹⁾

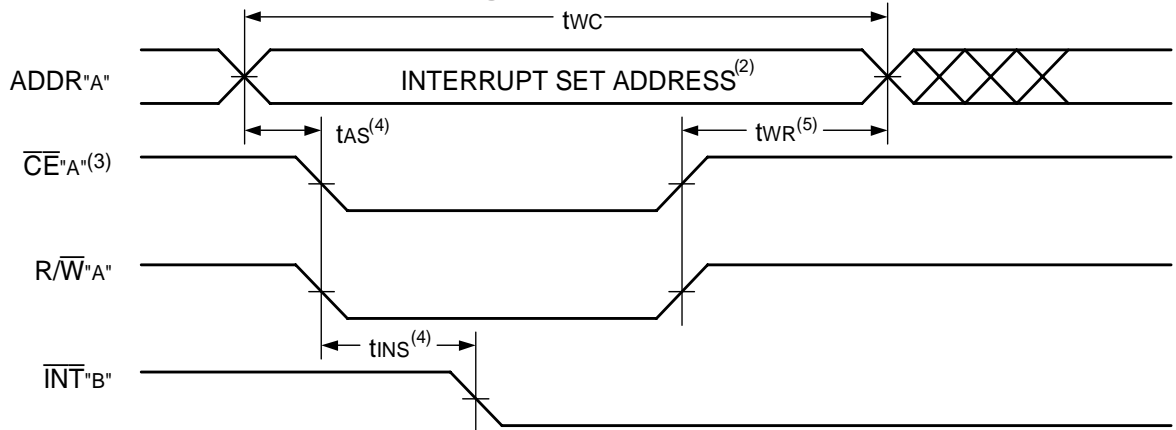

5670 drw 18

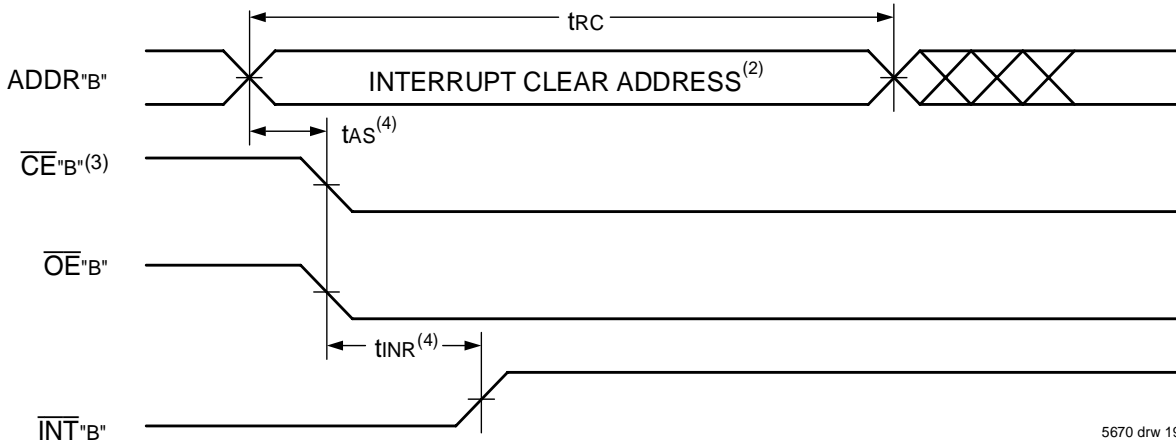

5670 drw 19

NOTES:

1. All timing is the same for left and right ports. Port "A" may be either the left or right port. Port "B" is the port opposite from port "A".
2. Refer to Interrupt Truth Table.
3. $\overline{CE}_x = V_{IL}$ means $\overline{CE}_{0x} = V_{IL}$ and $CE_{1x} = V_{IH}$. $\overline{CE}_x = V_{IH}$ means $\overline{CE}_{0x} = V_{IH}$ and/or $CE_{1x} = V_{IL}$.
4. Timing depends on which enable signal (\overline{CE} or R/\overline{W}) is asserted last.
5. Timing depends on which enable signal (\overline{CE} or R/\overline{W}) is de-asserted first.

Truth Table III — Interrupt Flag^(1,4)

Left Port					Right Port					Function
R/W _L	\overline{CE}_L	\overline{OE}_L	A _{18L-A_{0L}(5)}	\overline{INT}_L	R/W _R	\overline{CE}_R	\overline{OE}_R	A _{18R-A_{0R}(5)}	\overline{INT}_R	
L	L	X	7FFFF	X	X	X	X	X	L ⁽²⁾	Set Right \overline{INT}_R Flag
X	X	X	X	X	X	L	L	7FFFF	H ⁽³⁾	Reset Right \overline{INT}_R Flag
X	X	X	X	L ⁽³⁾	L	L	X	7FFFE	X	Set Left \overline{INT}_L Flag
X	L	L	7FFFE	H ⁽²⁾	X	X	X	X	X	Reset Left \overline{INT}_L Flag

5670 tbl 17

NOTES:

1. Assumes $\overline{BUSY}_L = \overline{BUSY}_R = V_{IH}$. $\overline{CE}_x = L$ means $\overline{CE}_{0x} = V_{IL}$ and $CE_{1x} = V_{IH}$.
2. If $\overline{BUSY}_L = V_{IL}$, then no change.
3. If $\overline{BUSY}_R = V_{IL}$, then no change.
4. \overline{INT}_L and \overline{INT}_R must be initialized at power-up.
5. A_{18x} is a NC for IDT70T631. Therefore, Interrupt Addresses are 3FFFF and 3FFFE.

Truth Table IV — Address $\overline{\text{BUSY}}$ Arbitration

Inputs			Outputs		Function
$\overline{\text{CE}}_{\text{L}}^{(5)}$	$\overline{\text{CE}}_{\text{R}}^{(5)}$	A ₀ L-A ₁₈ L ⁽⁴⁾ A ₀ R-A ₁₈ R	$\overline{\text{BUSY}}_{\text{L}}^{(1)}$	$\overline{\text{BUSY}}_{\text{R}}^{(1)}$	
X	X	NO MATCH	H	H	Normal
H	X	MATCH	H	H	Normal
X	H	MATCH	H	H	Normal
L	L	MATCH	(2)	(2)	Write Inhibit ⁽³⁾

5670 tbl 18

NOTES:

1. Pins $\overline{\text{BUSY}}_{\text{L}}$ and $\overline{\text{BUSY}}_{\text{R}}$ are both outputs when the part is configured as a master. Both are inputs when configured as a slave. $\overline{\text{BUSY}}$ outputs on the IDT70T633/1 are push-pull, not open drain outputs. On slaves the $\overline{\text{BUSY}}$ input internally inhibits writes.
2. "L" if the inputs to the opposite port were stable prior to the address and enable inputs of this port. "H" if the inputs to the opposite port became stable after the address and enable inputs of this port. If TAPS is not met, either $\overline{\text{BUSY}}_{\text{L}}$ or $\overline{\text{BUSY}}_{\text{R}}$ = LOW will result. $\overline{\text{BUSY}}_{\text{L}}$ and $\overline{\text{BUSY}}_{\text{R}}$ outputs can not be LOW simultaneously.
3. Writes to the left port are internally ignored when $\overline{\text{BUSY}}_{\text{L}}$ outputs are driving LOW regardless of actual logic level on the pin. Writes to the right port are internally ignored when $\overline{\text{BUSY}}_{\text{R}}$ outputs are driving LOW regardless of actual logic level on the pin.
4. A₁₈ is a NC for IDT70T631. Address comparison will be for A₀ - A₁₇.
5. $\overline{\text{CE}}_{\text{X}} = \text{L}$ means $\overline{\text{CE}}_{0\text{X}} = \text{V}_{\text{IL}}$ and $\overline{\text{CE}}_{1\text{X}} = \text{V}_{\text{IH}}$. $\overline{\text{CE}}_{\text{X}} = \text{H}$ means $\overline{\text{CE}}_{0\text{X}} = \text{V}_{\text{IH}}$ and/or $\overline{\text{CE}}_{1\text{X}} = \text{V}_{\text{IL}}$.

Truth Table V — Example of Semaphore Procurement Sequence^(1,2,3)

Functions	D ₀ - D ₁₇ Left	D ₀ - D ₁₇ Right	Status
No Action	1	1	Semaphore free
Left Port Writes "0" to Semaphore	0	1	Left port has semaphore token
Right Port Writes "0" to Semaphore	0	1	No change. Right side has no write access to semaphore
Left Port Writes "1" to Semaphore	1	0	Right port obtains semaphore token
Left Port Writes "0" to Semaphore	1	0	No change. Left port has no write access to semaphore
Right Port Writes "1" to Semaphore	0	1	Left port obtains semaphore token
Left Port Writes "1" to Semaphore	1	1	Semaphore free
Right Port Writes "0" to Semaphore	1	0	Right port has semaphore token
Right Port Writes "1" to Semaphore	1	1	Semaphore free
Left Port Writes "0" to Semaphore	0	1	Left port has semaphore token
Left Port Writes "1" to Semaphore	1	1	Semaphore free

5670 tbl 19

NOTES:

1. This table denotes a sequence of events for only one of the eight semaphores on the IDT70T633/1.
2. There are eight semaphore flags written to via I/O₀ and read from all I/O's (I/O₀-I/O₁₇). These eight semaphores are addressed by A₀ - A₂.
3. $\overline{\text{CE}}_0 = \text{V}_{\text{IH}}$, $\overline{\text{CE}}_1 = \overline{\text{SEM}} = \text{V}_{\text{IL}}$ to access the semaphores. Refer to the Semaphore Read/Write Control Truth Table.

Functional Description

The IDT70T633/1 provides two ports with separate control, address and I/O pins that permit independent access for reads or writes to any location in memory. The IDT70T633/1 has an automatic power down feature controlled by $\overline{\text{CE}}$. The $\overline{\text{CE}}_0$ and $\overline{\text{CE}}_1$ control the on-chip power down circuitry that permits the respective port to go into a standby mode when not selected ($\overline{\text{CE}} = \text{HIGH}$). When a port is enabled, access to the entire memory array is permitted.

Interrupts

If the user chooses the interrupt function, a memory location (mail box or message center) is assigned to each port. The left port interrupt

flag ($\overline{\text{INT}}_{\text{L}}$) is asserted when the right port writes to memory location 7FFFE (HEX), where a write is defined as $\overline{\text{CE}}_{\text{R}} = \text{R}/\overline{\text{W}}_{\text{R}} = \text{V}_{\text{IL}}$ per the Truth Table. The left port clears the interrupt through access of address location 7FFFE when $\overline{\text{CE}}_{\text{L}} = \overline{\text{OE}}_{\text{L}} = \text{V}_{\text{IL}}$, $\text{R}/\overline{\text{W}}$ is a "don't care". Likewise, the right port interrupt flag ($\overline{\text{INT}}_{\text{R}}$) is asserted when the left port writes to memory location 7FFFF (HEX) and to clear the interrupt flag ($\overline{\text{INT}}_{\text{R}}$), the right port must read the memory location 7FFFF. The message (18 bits) at 7FFFE or 7FFFF (3FFFF or 3FFFE for IDT70T631) is user-defined since it is an addressable SRAM location. If the interrupt function is not used, address locations 7FFFE and 7FFFF are not used as mail boxes, but as part of the random access memory. Refer to Truth Table III for the interrupt operation.

Busy Logic

Busy Logic provides a hardware indication that both ports of the RAM have accessed the same location at the same time. It also allows one of the two accesses to proceed and signals the other side that the RAM is "Busy". The $\overline{\text{BUSY}}$ pin can then be used to stall the access until the operation on the other side is completed. If a write operation has been attempted from the side that receives a $\overline{\text{BUSY}}$ indication, the write signal is gated internally to prevent the write from proceeding.

The use of $\overline{\text{BUSY}}$ logic is not required or desirable for all applications. In some cases it may be useful to logically OR the $\overline{\text{BUSY}}$ outputs together and use any $\overline{\text{BUSY}}$ indication as an interrupt source to flag the event of an illegal or illogical operation. If the write inhibit function of $\overline{\text{BUSY}}$ logic is not desirable, the $\overline{\text{BUSY}}$ logic can be disabled by placing the part in slave mode with the $\overline{\text{M/S}}$ pin. Once in slave mode the $\overline{\text{BUSY}}$ pin operates solely as a write inhibit input pin. Normal operation can be programmed by tying the $\overline{\text{BUSY}}$ pins HIGH. If desired, unintended write operations can be prevented to a port by tying the $\overline{\text{BUSY}}$ pin for that port LOW.

The $\overline{\text{BUSY}}$ outputs on the IDT70T633/1 RAM in master mode, are push-pull type outputs and do not require pull up resistors to operate. If these RAMs are being expanded in depth, then the $\overline{\text{BUSY}}$ indication for the resulting array requires the use of an external AND gate.

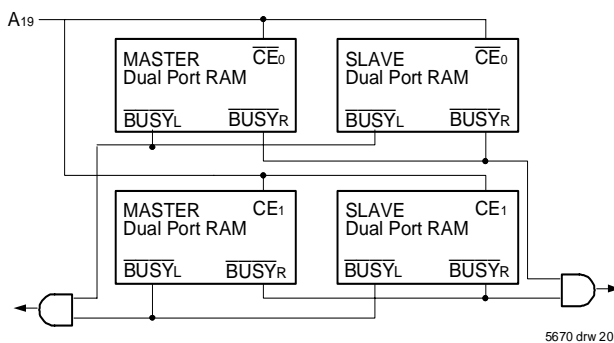

Figure 3. Busy and chip enable routing for both width and depth expansion with IDT70T633/1 Dual-Port RAMs.

Width Expansion with Busy Logic Master/Slave Arrays

When expanding an IDT70T633/1 RAM array in width while using $\overline{\text{BUSY}}$ logic, one master part is used to decide which side of the RAMs array will receive a $\overline{\text{BUSY}}$ indication, and to output that indication. Any number of slaves to be addressed in the same address range as the master use the $\overline{\text{BUSY}}$ signal as a write inhibit signal. Thus on the IDT70T633/1 RAM the $\overline{\text{BUSY}}$ pin is an output if the part is used as a master ($\overline{\text{M/S}}$ pin = V_{IH}), and the $\overline{\text{BUSY}}$ pin is an input if the part used as a slave ($\overline{\text{M/S}}$ pin = V_{IL}) as shown in Figure 3.

If two or more master parts were used when expanding in width, a split decision could result with one master indicating $\overline{\text{BUSY}}$ on one side of the array and another master indicating $\overline{\text{BUSY}}$ on one other side of the array. This would inhibit the write operations from one port for part of a word and inhibit the write operations from the other port for the other part of the word.

The $\overline{\text{BUSY}}$ arbitration on a master is based on the chip enable and

address signals only. It ignores whether an access is a read or write. In a master/slave array, both address and chip enable must be valid long enough for a $\overline{\text{BUSY}}$ flag to be output from the master before the actual write pulse can be initiated with the $\overline{\text{R/W}}$ signal. Failure to observe this timing can result in a glitched internal write inhibit signal and corrupted data in the slave.

Semaphores

The IDT70T633/1 is an extremely fast Dual-Port 512/256K x 18 CMOS Static RAM with an additional 8 address locations dedicated to binary semaphore flags. These flags allow either processor on the left or right side of the Dual-Port RAM to claim a privilege over the other processor for functions defined by the system designer's software. As an example, the semaphore can be used by one processor to inhibit the other from accessing a portion of the Dual-Port RAM or any other shared resource.

The Dual-Port RAM features a fast access time, with both ports being completely independent of each other. This means that the activity on the left port in no way slows the access time of the right port. Both ports are identical in function to standard CMOS Static RAM and can be read from or written to at the same time with the only possible conflict arising from the simultaneous writing of, or a simultaneous READ/WRITE of, a non-semaphore location. Semaphores are protected against such ambiguous situations and may be used by the system program to avoid any conflicts in the non-semaphore portion of the Dual-Port RAM. These devices have an automatic power-down feature controlled by $\overline{\text{CE0}}$ and $\overline{\text{CE1}}$, the Dual-Port RAM chip enables, and SEM, the semaphore enable. The $\overline{\text{CE0}}$, $\overline{\text{CE1}}$, and SEM pins control on-chip power down circuitry that permits the respective port to go into standby mode when not selected.

Systems which can best use the IDT70T633/1 contain multiple processors or controllers and are typically very high-speed systems which are software controlled or software intensive. These systems can benefit from a performance increase offered by the hardware semaphores of the IDT70T633/1, which provide a lockout mechanism without requiring complex programming.

Software handshaking between processors offers the maximum in system flexibility by permitting shared resources to be allocated in varying configurations. The IDT70T633/1 does not use its semaphore flags to control any resources through hardware, thus allowing the system designer total flexibility in system architecture.

An advantage of using semaphores rather than the more common methods of hardware arbitration is that wait states are never incurred in either processor. This can prove to be a major advantage in very high-speed systems.

How the Semaphore Flags Work

The semaphore logic is a set of eight latches which are independent of the Dual-Port RAM. These latches can be used to pass a flag, or token, from one port to the other to indicate that a shared resource is in use. The semaphores provide a hardware assist for a use assignment method called "Token Passing Allocation." In this method, the state of a semaphore latch is used as a token indicating that a shared resource is in use. If the left processor wants to use this resource, it requests the token by setting the latch. This processor then

verifies its success in setting the latch by reading it. If it was successful, it proceeds to assume control over the shared resource. If it was not successful in setting the latch, it determines that the right side processor has set the latch first, has the token and is using the shared resource. The left processor can then either repeatedly request that semaphore's status or remove its request for that semaphore to perform another task and occasionally attempt again to gain control of the token via the set and test sequence. Once the right side has relinquished the token, the left side should succeed in gaining control.

The semaphore flags are active LOW. A token is requested by writing a zero into a semaphore latch and is released when the same side writes a one to that latch.

The eight semaphore flags reside within the IDT70T633/1 in a separate memory space from the Dual-Port RAM array. This address space is accessed by placing a low input on the SEM pin (which acts as a chip select for the semaphore flags) and using the other control pins (Address, $\overline{CE}0$, CE1, R/\overline{W} and $\overline{LB}/\overline{UB}$) as they would be used in accessing a standard Static RAM. Each of the flags has a unique address which can be accessed by either side through address pins A0–A2. When accessing the semaphores, none of the other address pins has any effect.

When writing to a semaphore, only data pin D0 is used. If a low level is written into an unused semaphore location, that flag will be set to a zero on that side and a one on the other side (see Truth Table V). That semaphore can now only be modified by the side showing the zero. When a one is written into the same location from the same side, the flag will be set to a one for both sides (unless a semaphore request from the other side is pending) and then can be written to by both sides. The fact that the side which is able to write a zero into a semaphore subsequently locks out writes from the other side is what makes semaphore flags useful in interprocessor communications. (A thorough discussion on the use of this feature follows shortly.) A zero written into the same location from the other side will be stored in the semaphore request latch for that side until the semaphore is freed by the first side.

When a semaphore flag is read, its value is spread into all data bits so that a flag that is a one reads as a one in all data bits and a flag containing a zero reads as all zeros for a semaphore read, the \overline{SEM} , \overline{BEn} , and \overline{OE} signals need to be active. (Please refer to Truth Table II). Furthermore, the read value is latched into one side's output register when that side's semaphore select (\overline{SEM} , \overline{BEn}) and output enable (\overline{OE}) signals go active. This serves to disallow the semaphore from changing state in the middle of a read cycle due to a write cycle from the other side.

A sequence WRITE/READ must be used by the semaphore in order to guarantee that no system level contention will occur. A processor requests access to shared resources by attempting to write a zero into a semaphore location. If the semaphore is already in use, the semaphore request latch will contain a zero, yet the semaphore flag will appear as one, a fact which the processor will verify by the subsequent read (see Table V). As an example, assume a processor writes a zero to the left port at a free semaphore location. On a subsequent read, the processor will verify that it has written successfully to that location and will assume control over the resource in question. Meanwhile, if a processor on the right side attempts to write a zero to the same semaphore flag it will fail, as will be verified by the fact that a one will be read from that semaphore on the right side during subsequent read. Had a sequence of READ/WRITE been

used instead, system contention problems could have occurred during the gap between the read and write cycles.

It is important to note that a failed semaphore request must be followed by either repeated reads or by writing a one into the same location. The reason for this is easily understood by looking at the simple logic diagram of the semaphore flag in Figure 4. Two semaphore request latches feed into a semaphore flag. Whichever latch is first to present a zero to the semaphore flag will force its side of the semaphore flag LOW and the opposite side HIGH. This condition will continue until a one is written to the same semaphore request latch. If the opposite side semaphore request latch has been written to zero in the meantime, the semaphore flag will flip over to the other side as soon as a one is written into the first request latch. The

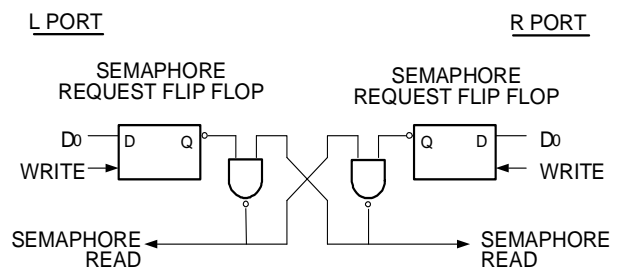

Figure 4. IDT70T633/1 Semaphore Logic 5670 drw 21

opposite side flag will now stay LOW until its semaphore request latch is written to a one. From this it is easy to understand that, if a semaphore is requested and the processor which requested it no longer needs the resource, the entire system can hang up until a one is written into that semaphore request latch.

The critical case of semaphore timing is when both sides request a single token by attempting to write a zero into it at the same time. The semaphore logic is specially designed to resolve this problem. If simultaneous requests are made, the logic guarantees that only one side receives the token. If one side is earlier than the other in making the request, the first side to make the request will receive the token. If both requests arrive at the same time, the assignment will be arbitrarily made to one port or the other.

One caution that should be noted when using semaphores is that semaphores alone do not guarantee that access to a resource is secure. As with any powerful programming technique, if semaphores are misused or misinterpreted, a software error can easily happen.

Initialization of the semaphores is not automatic and must be handled via the initialization program at power-up. Since any semaphore request flag which contains a zero must be reset to a one, all semaphores on both sides should have a one written into them at initialization from both sides to assure that they will be free when needed.

Timing Waveform of Sleep Mode^(1,2)

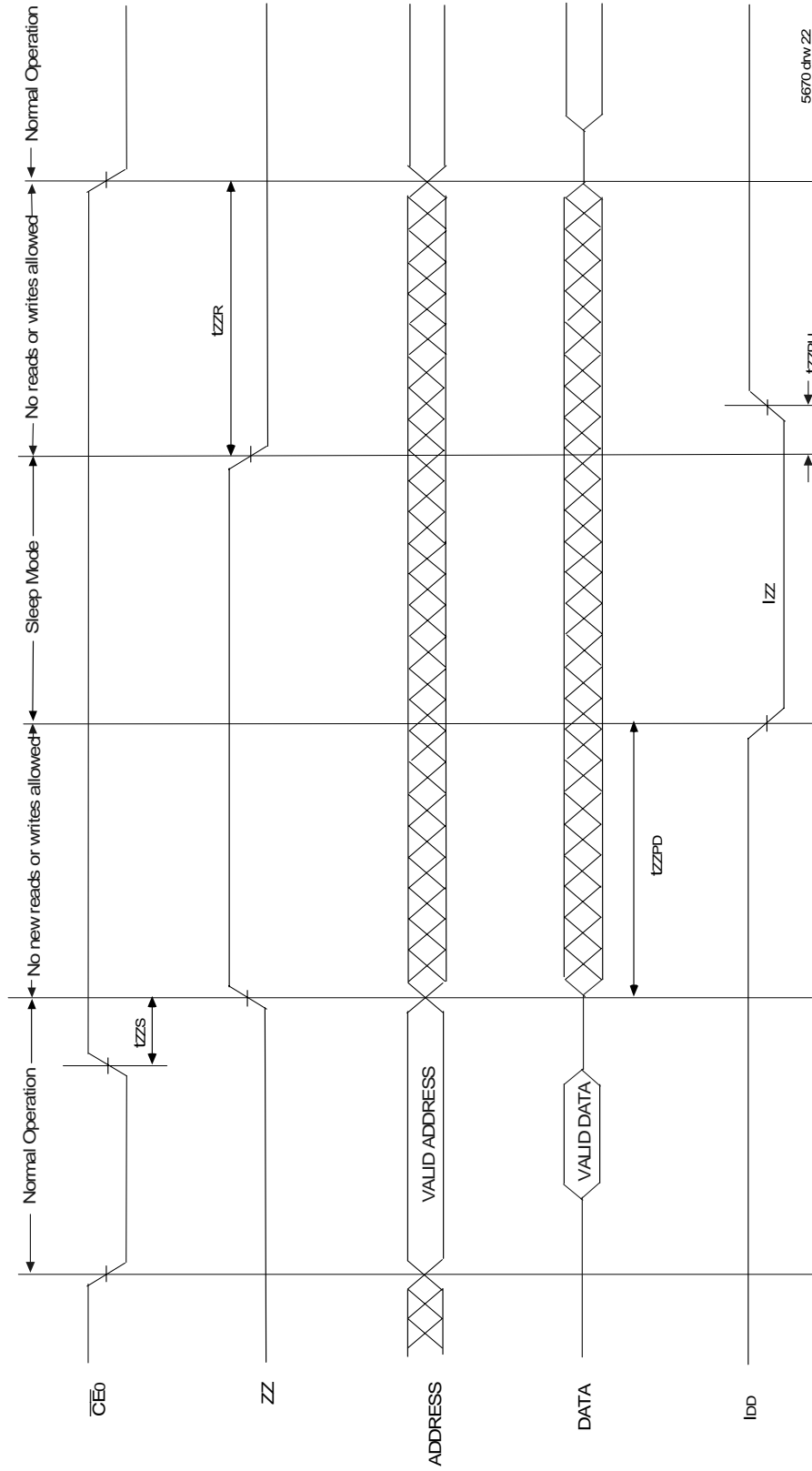

NOTES:

1. $CE1 = V_{IH}$.
2. All timing is same for Left and Right ports.

Sleep Mode

The IDT70T633/1 is equipped with an optional sleep or low power mode on both ports. The sleep mode pin on both ports is active high. During normal operation, the ZZ pin is pulled low. When ZZ is pulled high, the port will enter sleep mode where it will have the lowest possible power consumption. The sleep mode timing diagram demonstrates the modes of operation: Normal Operation, No Read/Write Allowed and Sleep Mode.

For a period of time prior to sleep mode and after recovering from sleep

mode (t_{zss} and t_{zsr}), new reads or writes are not allowed. If a write or read operation occurs during these periods, the memory array may be corrupted. Validity of data out from the RAM cannot be guaranteed immediately after ZZ is asserted (prior to being in sleep).

During sleep mode the RAM automatically deselects itself and disconnects its internal buffer. All outputs will remain in high-Z state while in sleep mode. All inputs are allowed to toggle, but the RAM will not be selected and will not perform any reads or writes.

JTAG Timing Specifications

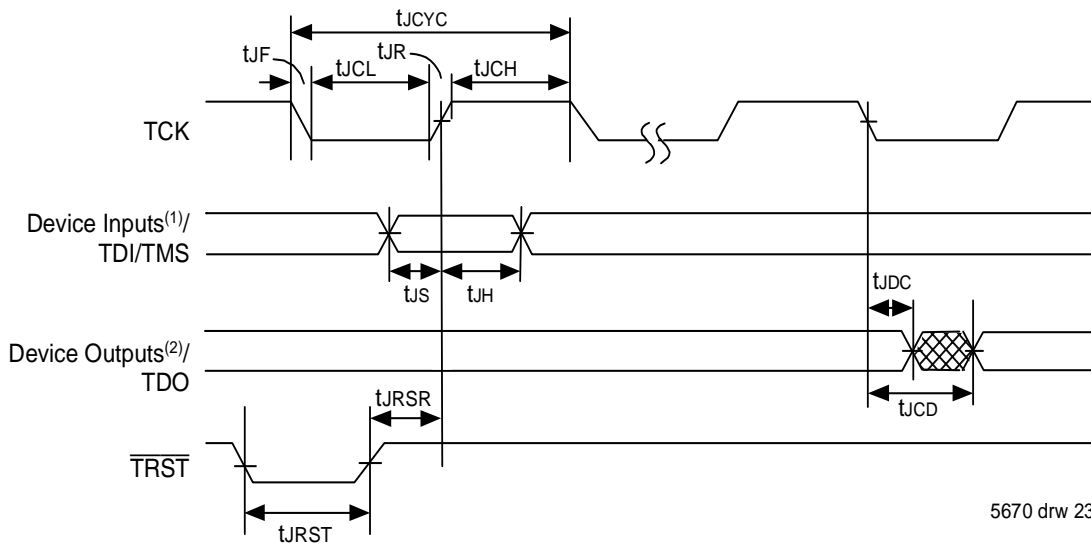

5670 drw 23

NOTES:

1. Device inputs = All device inputs except TDI, TMS, and TRST.
2. Device outputs = All device outputs except TDO.

JTAG AC Electrical Characteristics^(1,2,3,4,5)

Symbol	Parameter	70T633/1		
		Min.	Max.	Units
t_{JCYC}	JTAG Clock Input Period	100	—	ns
t_{JCH}	JTAG Clock HIGH	40	—	ns
t_{JCL}	JTAG Clock Low	40	—	ns
t_{JR}	JTAG Clock Rise Time	—	3 ⁽¹⁾	ns
t_{JF}	JTAG Clock Fall Time	—	3 ⁽¹⁾	ns
t_{JRST}	JTAG Reset	50	—	ns
t_{JRSR}	JTAG Reset Recovery	50	—	ns
t_{JCD}	JTAG Data Output	—	25	ns
t_{JDC}	JTAG Data Output Hold	0	—	ns
t_{JS}	JTAG Setup	15	—	ns
t_{JH}	JTAG Hold	15	—	ns

5670 tbl 20

NOTES:

1. Guaranteed by design.
2. 30pF loading on external output signals.
3. Refer to AC Electrical Test Conditions stated earlier in this document.
4. JTAG operations occur at one speed (10MHz). The base device may run at any speed specified in this datasheet.
5. JTAG cannot be tested in sleep mode.

Identification Register Definitions

Instruction Field	Value	Description
Revision Number (31:28)	0x0	Reserved for version number
IDT Device ID (27:12)	0x33B ⁽¹⁾	Defines IDT part number 70T633
IDT JEDEC ID (11:1)	0x33	Allows unique identification of device vendor as IDT
ID Register Indicator Bit (Bit 0)	1	Indicates the presence of an ID register

NOTE:

1. Device ID for IDT70T631 is 0x33C.

5670 tbl 21

Scan Register Sizes

Register Name	Bit Size
Instruction (IR)	4
Bypass (BYR)	1
Identification (IDR)	32
Boundary Scan (BSR)	Note (3)

5670 tbl 22

System Interface Parameters

Instruction	Code	Description
EXTEST	0000	Forces contents of the boundary scan cells onto the device outputs ⁽¹⁾ . Places the boundary scan register (BSR) between TDI and TDO.
BYPASS	1111	Places the bypass register (BYR) between TDI and TDO.
IDCODE	0010	Loads the ID register (IDR) with the vendor ID code and places the register between TDI and TDO.
HIGHZ	0100	Places the bypass register (BYR) between TDI and TDO. Forces all device output drivers to a High-Z state.
CLAMP	0011	Uses BYR. Forces contents of the boundary scan cells onto the device outputs. Places the bypass register (BYR) between TDI and TDO.
SAMPLE/PRELOAD	0001	Places the boundary scan register (BSR) between TDI and TDO. SAMPLE allows data from device inputs ⁽²⁾ and outputs ⁽¹⁾ to be captured in the boundary scan cells and shifted serially through TDO. PRELOAD allows data to be input serially into the boundary scan cells via the TDI.
RESERVED	All other codes	Several combinations are reserved. Do not use codes other than those identified above.

NOTES:

1. Device outputs = All device outputs except TDO.
2. Device inputs = All device inputs except TDI, TMS, and $\overline{\text{TRST}}$.
3. The Boundary Scan Descriptive Language (BSDL) file for this device is available on the IDT website (www.idt.com), or by contacting your local IDT sales representative.

5670 tbl 23

Ordering Information

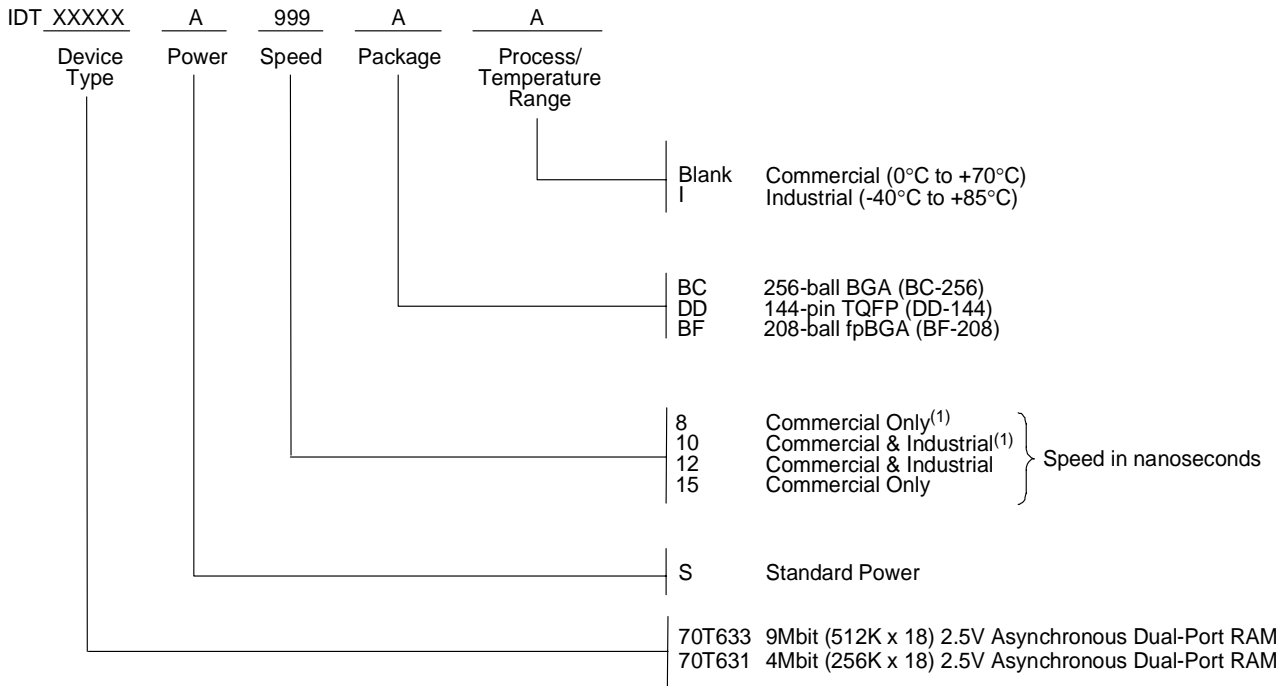

5670 drw 24

NOTE:

1. 8ns Commercial and 10ns Industrial speed grades are available in BF-208 and BC-256 packages only

Preliminary Datasheet: Definition

"PRELIMINARY" datasheets contain descriptions for products that are in early release.

Datasheet Document History:

- 04/25/03: Initial Datasheet
- 10/01/03: Page 9 Added 8ns speed DC power numbers to DC Electrical Characteristics Table
 Page 9 Updated DC power numbers for 10, 12 & 15ns speeds in the DC Electrical Characteristics Table
 Page 9, 11, 15, 17 & 25 Added footnote that indicates that 8ns speed is available in BF-208 and BC-256 packages only
 Page 10 Added Capacitance Derating Drawing
 Page 11, 15 & 17 Added 8ns AC timing numbers to the AC Electrical Characteristics Tables
 Page 11 Added t_{SOE} and t_{LZOB} to the AC Read Cycle Electrical Characteristics Table
 Page 12 Added t_{LZOB} to the Waveform of Read Cycles Drawing
 Page 14 Added t_{SOE} to Timing Waveform of Semaphore Read after Write Timing, Either Side Drawing
 Page 1 & 25 Added 8ns speed grade and 10ns I-temp to features and to ordering information
 Page 1, 14 & 15 Added RapidWrite Mode Write Cycle text and waveforms
- 10/20/03: Page 15 Corrected t_{ARF} to 1.5V/ns Min.



CORPORATE HEADQUARTERS
 2975 Stender Way
 Santa Clara, CA 95054

for SALES:
 800-345-7015 or 408-727-6116
 fax: 408-492-8674
 www.idt.com

for Tech Support:
 831-754-4613
 DualPortHelp@idt.com

The IDT logo is a registered trademark of Integrated Device Technology, Inc.