



ADVANCE INFORMATION

CIP 3250A
Component Interface
Processor

Edition Oct. 9, 1996
6251-403-3AI

 **MICRONAS**

Contents

Page	Section	Title
4	1.	Introduction
4	1.1.	Block Diagram
4	1.2.	System Configurations
7	2.	Functional Description
7	2.1.	Analog Front End
7	2.2.	Clamping
7	2.3.	Matrix
7	2.4.	YUV Control (on RGB-path only)
8	2.5.	Delay Adjustment
8	2.6.	Skew Filter
8	2.7.	Fast Blank Processing
8	2.7.1.	Soft Mixer
9	2.7.2.	Fast Blank Monitor
9	2.8.	FSY Front Sync and AVI Active Video In
10	2.9.	Digital Input Formats
10	2.9.1.	The Chroma Demultiplexers
11	2.10.	YUVin Interpolator (LPF 4:4:4)
11	2.11.	YUV Output Low-pass Filter 4:2:2 and 4:1:1
13	2.12.	Selectable RGB/YUV Output Formats
14	2.12.1.	DIGIT 2000 4:1:1 Output Format
14	2.12.2.	DIGIT 2000 4:2:2 Output Format
14	2.12.3.	DIGIT 3000 Orthogonal 4:2:2 Output Format
15	2.12.4.	Orthogonal 4:1:1 Output Format
15	2.12.5.	YUV Output Levels
15	2.13.	I/O Code Levels
15	2.14.	AVO Active Video Output
15	2.15.	PRIO Interface
16	2.16.	I ² C Serial Bus Control
27	3.	Specifications
27	3.1.	Outline Dimensions
27	3.2.	Pin Connections and Short Descriptions
30	3.3.	Pin Descriptions
32	3.4.	Pin Configuration
33	3.5.	Pin Circuits
35	3.6.	Electrical Characteristics
35	3.6.1.	Absolute Maximum Ratings
35	3.6.2.	Recommended Operating Conditions
36	3.6.3.	Characteristics
36	3.6.3.1.	Characteristics Standby Input
36	3.6.3.2.	Characteristics Test Input
36	3.6.3.3.	Characteristics Reset Input
37	3.6.3.4.	Characteristics Main Clock Input
37	3.6.3.5.	Characteristics Active Video Output
38	3.6.3.6.	Characteristics Active Video Input
38	3.6.3.7.	Characteristics Fsync Input
39	3.6.3.8.	Characteristics I ² C Bus Interface Input/Output
39	3.6.3.9.	Characteristics Luma/Chroma Input

Contents, continued

Page	Section	Title
40	3.6.3.10.	Characteristics Priority Input/Output
41	3.6.3.11.	Characteristics Picture Output
42	3.6.3.12.	Characteristics Analog R, G, B Inputs
42	3.6.3.13.	Characteristics Analog FBL Input
43	4.	Application Circuit
44	5.	Data Sheet History

Component Interface Processor

Release Notes: Revision bars indicate significant changes to the previous edition.

1. Introduction

The CIP 3250A is a new CMOS IC that contains on a single chip the entire circuitry to interface analog YUV/RGB/Fast Blank to a digital YUV system. The Fast Blank signal is used to control a soft mixer between the digitized RGB and an external digital YUV source. The CIP supports various output formats such as YUV 4:1:1/4:2:2 or RGB 4:4:4.

Together with the DIGIT 3000 (e.g. VPC 32xxA) or DIGIT 2000 (e.g. DTI 2250), an interface to a TV-scanrate conversion circuit and/or multi-media frame buffer can be obtained.

1.1. Block Diagram

The CIP 3250A contains the following main functional blocks (see Fig.1–1):

- analog input for RGB or YUV and Fast Blank
- triple 8 bit analog to digital converters for RGB/YUV with internal programmable clamping
- single 6 bit analog to digital converter for Fast Blank signal

- digital matrix RGB ⇒ YUV (Y, B–Y, R–Y)
- luma contrast and brightness correction for signals from analog input
- color saturation and hue correction for signals from analog input
- digital input for DIGIT 2000 or DIGIT 3000 formats
- digital interpolation to 4:4:4 format
- high quality soft mixer controlled by Fast Blank signal
- programmable delays to match digital YUVin and analog RGB/YUV
- variable low pass filters for YUV output
- digital output in DIGIT 2000 and DIGIT 3000 formats, as well as RGB 4:4:4
- I²C bus interface
- clock frequency 13.5...20.25 MHz

1.2. System Configurations

The following figures, 1–2 and 1–3, show different basic system applications for the CIP 3250A in the DIGIT 3000 environment. Beyond that, a stand alone application (figure 1–4) also shows the flexibility of the CIP 3250A in implementing simple analog video interfaces to digital standards.

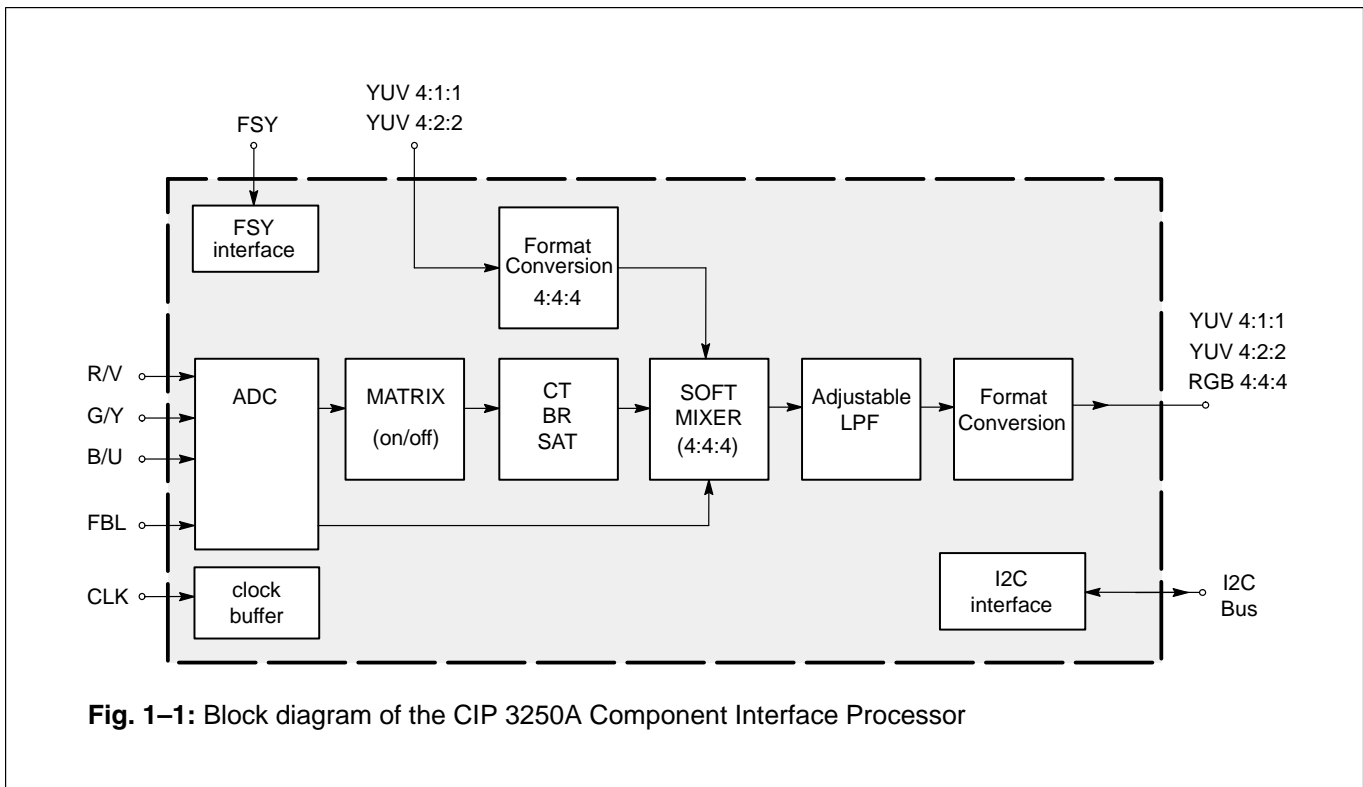
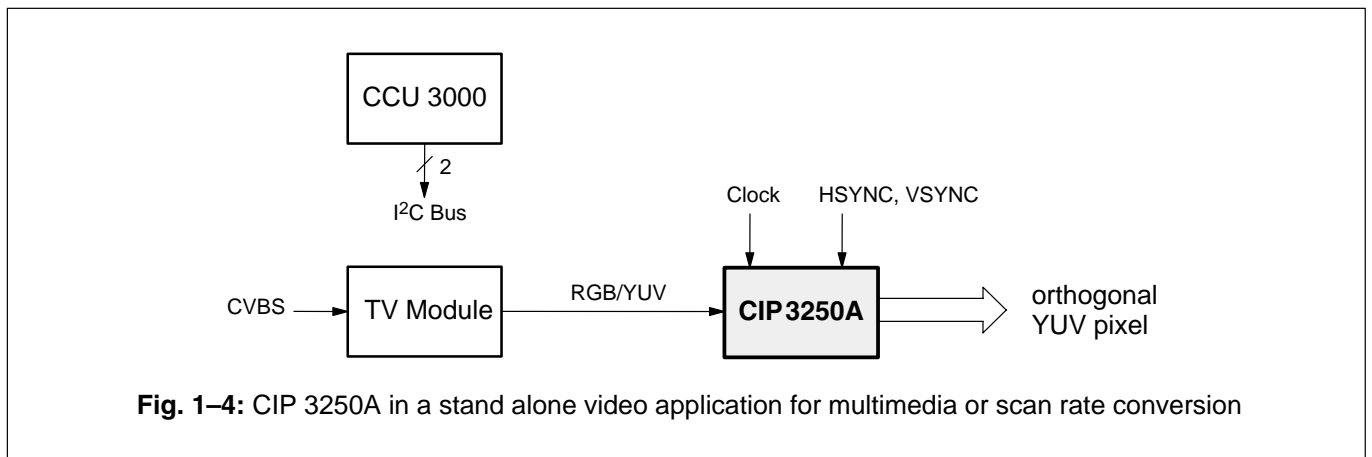
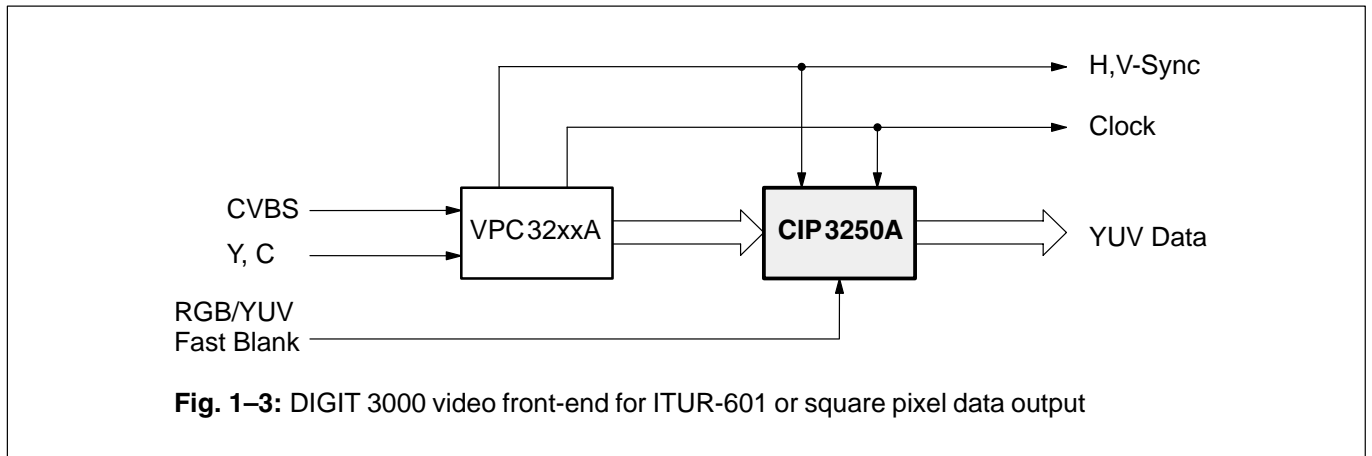
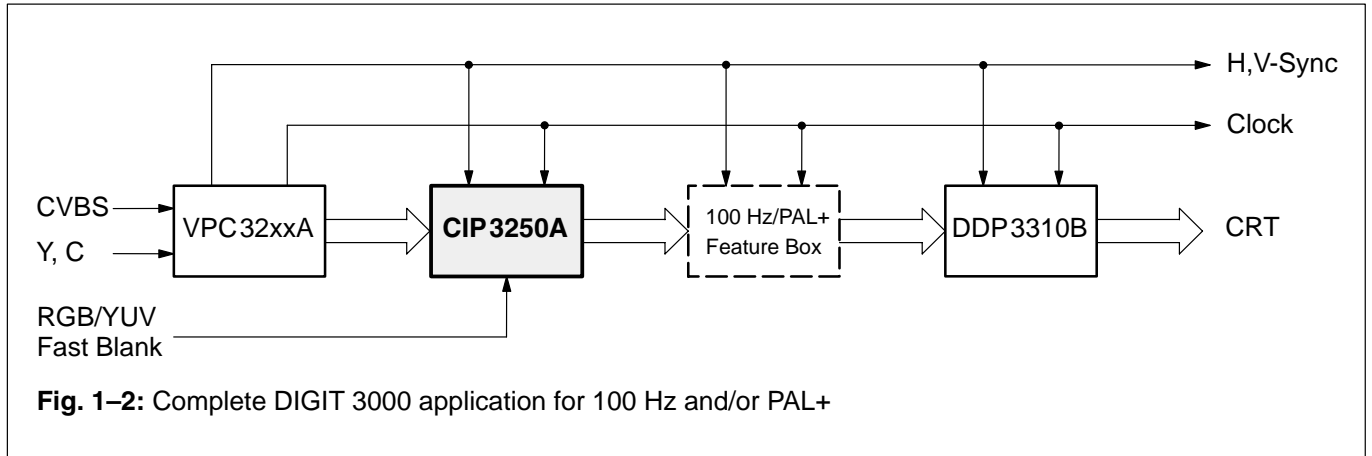

Fig. 1–1: Block diagram of the CIP 3250A Component Interface Processor



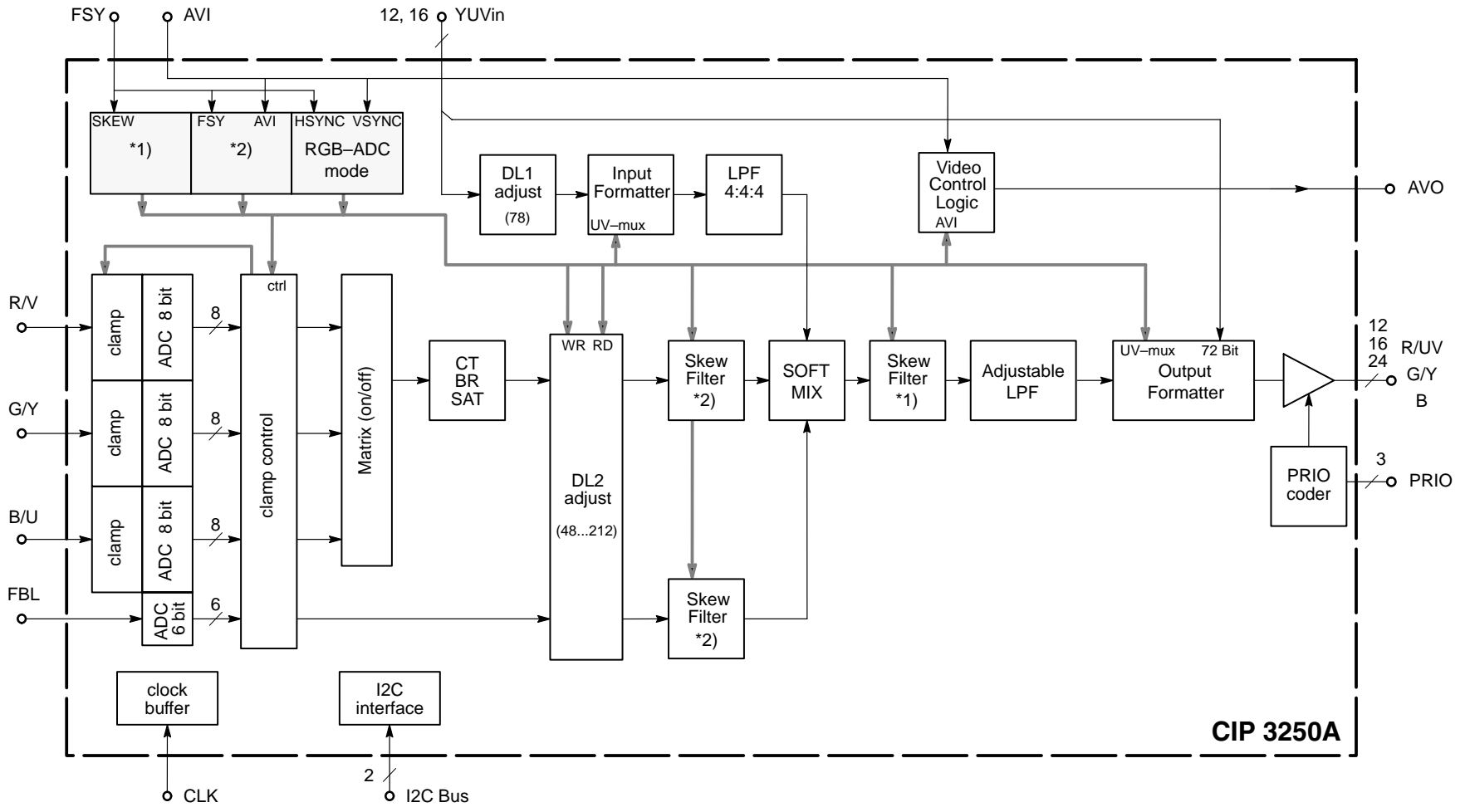

Fig. 2-1: CIP 3250A block diagram

Note:

*1) Only used in DIGIT 2000 mode

*2) Only used in DIGIT 3000 mode

2. Functional Description

This section describes the functionality of the various blocks shown in the block diagram of Fig. 2–1 in detail. The CIP 3250A is controlled via an I²C bus interface. For information regarding how to program the registers of the CIP 3250A, please refer to the register list (see Tables 2–9 and 2–10). The I²C bus interface uses sub-addressing to access the register. In the following, I²C registers are referenced by the sub-addresses given in parenthesis; for example, I²C register <9>. To interface correctly, a pin description for the CIP 3250A is given in section 3.3.

2.1. Analog Front End

- SCART-level inputs (RGB/YUV and Fast Blank = 1.0 V_{pp}, Fast Blank must be ext. clipped)
- triple 8-bit ADC for RGB/YUV
- 6 bit ADC for Fast Blank
- sampling rate 13.5 to 20.25 MHz
- no sync separation included

All analog video input signals and the analog Fast Blank signal must be band limited to 5 MHz before analog to digital conversion.

The CIP 3250A can process either analog YUV input signals or analog RGB input signals which are AC-coupled with a nominal input voltage level of 700 mV + 3 dB (1 V_{pp}). There is no circuitry implemented for internal sync separation. Input voltage range of the Fast Blank signal is 0 to 1 V. The Fast Blank input signal is DC-coupled.

2.2. Clamping

- internal clamping for RGB and YUV with adjustable start and width
- black level reference only during horizontal and vertical blanking interval on RGB/YUV inputs
- no proper clamping if sync is on G

In RGB mode, clamping takes place on black level (digital 16 or 8) using a clamping window as described below. In YUV mode, clamping is done on black level (digital 16) for Y (luma) and on saturation level zero (digital 128) for UV (chroma) using a clamping window. Select between RGB mode and YUV mode via I²C register <09>YUV. The black level reference value (digital 16 or 8) can be selected via I²C register <09>CLMPOFS. In a standard DIGIT 2000 application without a conversion of Y (luma) to ITUR code levels at the digital inputs (see section 2.9. <10>YLEVEL), convert the black level to digital 32 via I²C register <04>CLSEL.

The clamping window is programmable in reference to the H-sync signal (see Fig. 2–13) by a start and stop val-

ue via I²C registers <18> and <19>. A window size of 32 or 64 sample clocks is recommended. Clamping is disabled if start and stop values are equal after reset. Once enabled it can not be switched off. Using a coupling capacitor of 220 nF, a hum of approximately 400 mV at 50 Hz can be compensated.

2.3. Matrix

- matrix RGB ⇒ Y(R–Y)(B–Y):

$$Y = 0.299 * R + 0.587 * G + 0.114 * B$$

$$(R - Y) = 0.701 * R - 0.587 * G - 0.114 * B$$

$$(B - Y) = -0.299 * R - 0.587 * G + 0.886 * B$$

- fixed coefficients with a resolution of 8 bits.

- matrix enable/disable for analog RGB/YUV input programmable via I²C register

The matrix of the CIP 3250A converts the digitized RGB signals to the intermediate signals Y, R–Y, and B–Y. Enable the matrix via I²C register <04>MAON. The intermediate signals at the output of the matrix can be converted to YUV signals of the DIGIT 2000 system or to YC_rC_b of the DIGIT 3000 system by the YUV control (see section 2.4.). To omit conversion from RGB to Y(R–Y)(B–Y), switch off the matrix and the CTBRST block via I²C register <04>MAON and <04>CBSON.

2.4. YUV Control (on RGB-path only)

- Y contrast (ct) and brightness (br) with rounding or noise shaping and limiting to 8 bit:

$$Y = Y * ct + br$$

$$ct = 0 \dots 63/32 \text{ in } 64 \text{ steps}$$

$$br = -128 \dots +127 \text{ in } 256 \text{ steps}$$
- UV saturation (sat) with rounding or noise shaping and limiting to 8 bit (controllable by CCU via I²C bus):

$$U_{EXT} = (B - Y) * Usat$$

$$V_{EXT} = (R - Y) * Vsat$$

$$Usat, Vsat = 0 \dots 63/32 \text{ in } 64 \text{ steps}$$

$$(U_{INT} = [0.5 * (B - Y)] * Usat)$$

$$(V_{INT} = [0.875 * (R - Y)] * Vsat)$$

Within the CTBRST block, switched on via I²C register <04>CBSON, two different options can be used to convert from (R–Y)(B–Y) to UV (PAL standard). In internal mode (UV_{INT}), conversion to PAL standard is done before the multiplication of the contents of the saturation registers. Using the external mode (UV_{EXT}) of <04>SMODE, the user has to implement the conversion factors via the two saturation registers (Usat, Vsat). Since the two saturation registers can be programmed separately, it is also very easy to convert to YC_rC_b (Studio standard) of the DIGIT 3000 system.

Contrast, brightness, and saturation can be adjusted for the video signals of the analog input via I²C registers <00> to <03>. A functional description of this circuit can be found in figures 2–2 and 2–3 respectively.

To improve the amplitude resolution of the luma (Y) and chroma (UV) video signals after multiplication with the

weighting factors (ct) and (sat), the user can select between rounding and two different modes of noise shaping (1 bit error diffusion or 2 bit error diffusion).

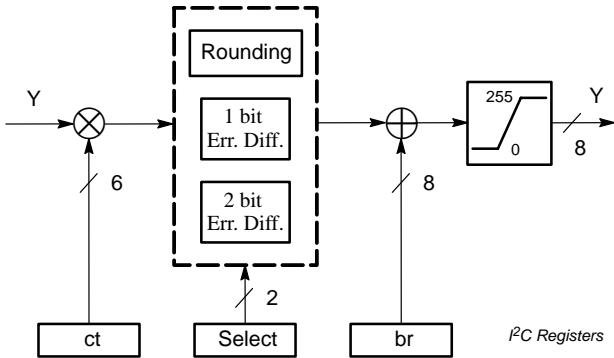

Fig. 2-2: Luma Contrast & Brightness Adjustment

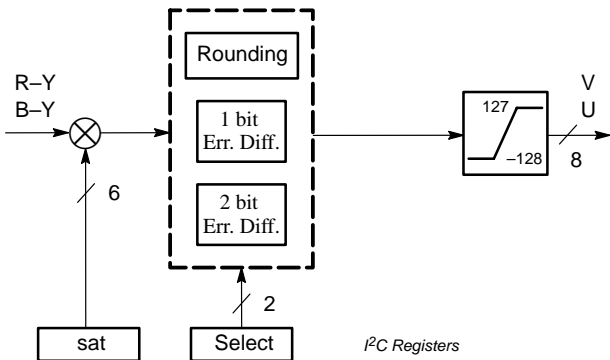

Fig. 2-3: Chroma Saturation Adjustment

2.5. Delay Adjustment

- DL1 to compensate internal processing delay of the CIP 3250A in reference to digital YUVin
- DL1 to compensate processing delay of the DIGIT 2000 SPU chroma channel in SECAM mode
- DL2 to compensate delay between digital YUVin and analog RGBin or FSY; as for example, produced by ACVP or SPU.

To mix the analog RGB/YUV input signals and the digital YUVin input signals at the soft mixer correctly, in reference to the horizontal synchronization pulse, two processing delay adjustments can be made. In many system applications, ICs in front of the CIP 3250A cause a fixed processing delay in the digital YUVin path. Therefore, a delay of up to 210 sample clocks can be programmed via I²C register <21>DL2 to match analog RGB/YUV data with digital YUV data. If the delay is less than 48 sample clocks, the DL1 block can be activated (80 sample clocks) via I²C register <10>DL1ON to get a value for <21>DL2 within the range of 48 to 210.

In applications where there will be no fixed delay between digital YUVin and analog RGB/YUV, the pixel skew correction can be switched on via I²C register

<17>PXSKWON. In this mode, the DL2 block serves as a variable delay to match the analog RGB/YUV data with digital YUV data. The first pixel of analog RGB/YUV written into the DL2 block (which works like a FIFO) is selected by <21>DL2. Read of the DL2 block starts synchronously with the AVI input, which in turn marks the first pixel in digital YUV data (see Fig. 2-14). Care must be taken that the number of pixels stored in DL2 block must be within the limits of 48 to 210.

In case of SECAM processing in the DIGIT 2000 environment, the digital luma and chroma signals do not match in front of the CIP 3250A. Therefore, the I²C register <10>SECAM must be enabled, and fine adjustment has to be carried out within the ACVP.

2.6. Skew Filter

Two interpolation filters perform data orthogonalization (= skew correction) for luma and chroma in case of a non-line-locked system clock. The skew value is serially input via the FSY input. In a system environment where digital YUV data are orthogonal (e.g. DIGIT 3000), the skew correction must be set to DIGIT 3000 mode via I²C register <04>SKWCBS in order to apply skew correction to analog RGB/YUV data only. Additionally, the skew correction must be switched on via I²C register <04>SKWON. This has to be done in order to mix the analog input with the digital YUV input correctly and to output the mixed YUV signal in an orthogonal format.

For standard DIGIT 2000 operation, the skew correction should be switched off via I²C register <04>SKWON, in order to output the mixed YUV data with the same skew values as the digital YUV input. Only in special applications (e.g. multi media), where the output connects to a field or frame memory which processes orthogonal data, the skew correction for mixed YUV data has to be switched on and set to DIGIT 2000 mode via I²C register <04>SKWCBS.

2.7. Fast Blank Processing

- mixing of RGB-path and YUV-path in YUV 4:4:4 format controlled by the Fast Blank signal
- linear or nonlinear mixing technique selectable
- programmable polarity of Fast Blank signal
- programmable step response of Fast Blank signal
- RGB-path or YUV-path can be statically selected
- Fast Blank signal monitoring

2.7.1. Soft Mixer

In the Fast Blank signal path, special hardware is supplied to improve edge effects, such as blurring because of band limiting in the analog front end. Different step responses are user selectable via I²C register <12>MIX-AMP, still obtaining high quality phase resolution. Also,

the polarity of the Fast Blank signal can be changed via I²C register <12>MIXAMP. The I²C register <11>FBLOFF influences the phase delay between the RGB path and the Fast Blank signal (see Fig. 2–4).

Additionally, a delay of –1 to 2 clocks between the Fast Blank signal and the RGB-path is programmable via I²C register <16>FBLDEL. By selecting a positive delay, shadowing of characters can be obtained, if the background color of the RGB-path is set to black.

With the built-in linear mixer, the CIP 3250A is able to support simple AB roll techniques between analog input (A) and digital YUV input (B):

$$\text{VideoOut} = A * (1 - \text{FBLMIX}/32) + B * \text{FBLMIX}/32,$$

controllable via the Fast Blank signal (FBL):

$$\text{FBLMIX} = \text{INT}[(\text{FBL} - \text{FBLOFF}) * \text{MIXAMP}/2] + 16,$$

with FBL of values from 0 to 63. The mixing coefficient FBLMIX resolves 32 steps within the range from 0 to 32 (dependent on step response chosen via I²C register <12>MIXAMP) (see Fig. 2–4).

When the I²C register bit <16>FBLCLP is enabled, the soft mixer operates independently of the analog Fast Blank input. FBL is clamped to digital 31 (see Fig. 2–4). Mixing between RGB-path and YUV-path is controllable via the I²C register <11>FBLOFF.

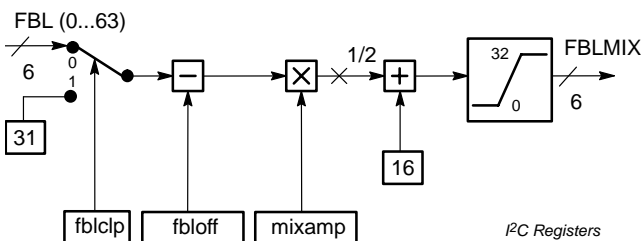

Fig. 2–4: Fast Blank Processing

Select the linear mixer or the nonlinear mixer via I²C register <12>SELLIN. If the nonlinear mixer is selected, a dynamic delay control of the analog RGB/YUV input can be chosen, to avoid edge artefacts of the RGB/YUV signal (e.g. shading), during transition time of Fast Blank signal with the I²C register <12>CTRLDLY.

In some applications, it is desired to disable the control by the Fast Blank signal and to pass through the digital YUVin path or the analog RGB/YUV path. This is possible by adequately programming the I²C registers <06>PASSYUV and <11>PASSRGB (Table 2–1).

Table 2–1: Source selection of soft mixer

<11> PASSRGB	<06> PASSYUV	Fast Blank signal	Source
0	X	X	RGB
1	0	MIX	YUV/RGB
1	1	X	YUV
X: don't care			

2.7.2. Fast Blank Monitor

Bits 0 to 3 of I²C register <27> are monitoring the analog Fast Blank input. Reading I²C register <27> Fig. 2–5 displays the contents depending on the analog FBL input signal.

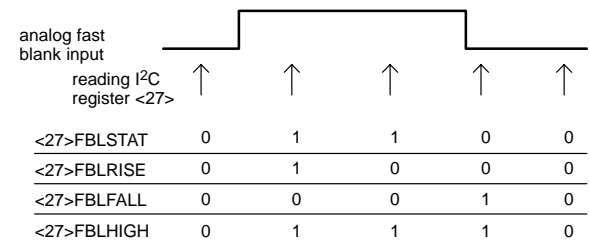

Fig. 2–5: Fast Blank Monitor

2.8. FSY Front Sync and AVI Active Video In

- DIGIT 2000 chroma sync detection
- DIGIT 2000 throughput of 72-bit data and clock
- skew data input for DIGIT 2000
- skew data input for DIGIT 3000
- HSYNC as timing reference for clamping pulse generator
- active video input to indicate valid video data and to synchronize chroma multiplex for DIGIT 3000

The FSY input and the AVI input are used to supply all synchronization information necessary. Three basic modes of operation can be selected via I²C registers <06>D2KIN, <17>D2KSYNC, <17>SYNCSIM, and <17>P72BEN.

In a DIGIT 2000 system environment, the CIP 3250A receives the synchronization information at the FSY input via the DIGIT 2000 SKEW-protocol. The AVI Input may be connected to ground GND or VDD (see section 2.14.).

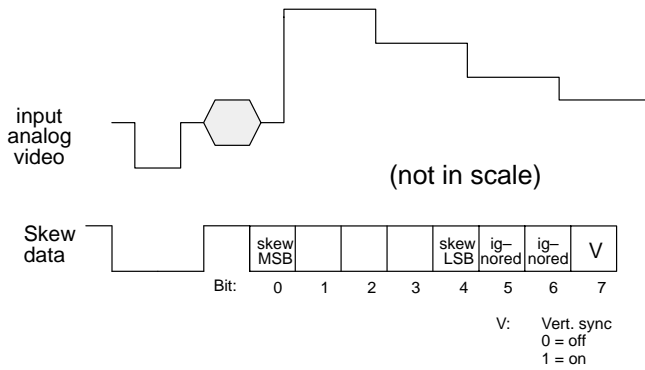

Fig. 2–6: DIGIT 2000 skew data

In a DIGIT 3000 system environment, the CIP 3250A receives the synchronization information at the FSY input via the DIGIT 3000 FSY-protocol (see Fig. 2–7). The AVI input receives the chroma multiplex information implicitly with the rising edge of the AVI signal.

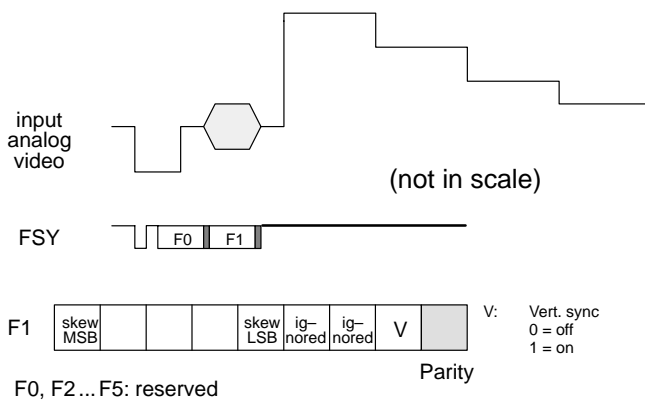

Fig. 2–7: DIGIT 3000 front sync format

In a stand alone application, for example, RGB-analog-to-digital conversion, a horizontal sync pulse must serve the FSF input, and a vertical sync pulse must serve the AVI input. The polarity of these two sync pulses can be programmed via I²C registers <10>AVIINV and <07>FSYINV.

Inside the CIP 3250A, synchronization information is being decoded and used to control clamping, DL2, skew filters, video control logic, input formatter, and output formatter as shown in Fig. 2–1.

2.9. Digital Input Formats

- YUV 4:2:2 (16 bit) from DIGIT 2000 and DIGIT 3000 (YUV as well as YCrCb)
- YUV 4:1:1 (12 bit) from DIGIT 2000
- input levels according to DIGIT 2000/DIGIT 3000

The CIP 3250A supports the YUV 4:1:1 (12 bit) standard from DIGIT 2000, the YUV 4:2:2 (16 bit) standard from

DIGIT 2000, and the YUV 4:2:2 (16 bit) standard from DIGIT 3000. Therefore, the CIP 3250A can be used in either the DIGIT 2000 system environment or the DIGIT 3000 system environment. Refer to I²C registers <06>DELAYU, <10>UVFRM3, and <10>UVFRM1 for a correct setup. Additionally, within the DIGIT 2000 system, a Y (luma) format conversion to ITU-R 601 can be achieved via programming the I²C register <10>YLEVEL.

Table 2–2: Digital input selection

<06> DELAYU	<11> UVFRM3	<11> UVFRM1	Digital Input Format
0	0	0	DIGIT 2000 4:2:2
0	0	1	DIGIT 2000 4:1:1
1	1	0	DIGIT 3000 4:2:2
1	0	0	MAC

2.9.1. The Chroma Demultiplexers

In DIGIT 2000 mode, via pins 36 to 39, the CIP 3250A receives the V and U signals from the C0 to C3 outputs of the color decoder, time-multiplexed in 4-bit nibbles (Fig. 2–8). For the digital signal processing, the 4-bit V and U chroma nibbles are demultiplexed to 8-bit signals by the V and U demultiplexers. Both demultiplexers are clocked by the main clock. They are synchronized to the V and U transmission during the vertical blanking period.

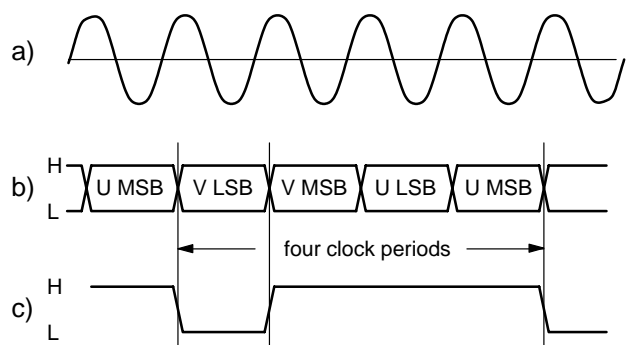

Fig. 2–8: Timing diagram of the multiplexed color difference signal transfer between decoder and CIP 3250A

Notes to Fig. 2–8:

- a) CLK main clock signal
- b) Multiplexed color difference signals from PVPU/ACVP/SPU/VSP/DMA to DTI 2260
- c) Sync pulse on C0 output during sync time in vertical blanking interval.

2.10. YUVin Interpolator (LPF 4:4:4)

- UV-Interpolation 4:1:1 or 4:2:2 \Rightarrow 4:4:4

In order to mix the digital input data with the 4:4:4 video standard from the analog RGB/YUV input, correctly, the chroma samples of the digital input have to be interpolated.

In case of YUV 4:1:1 input from DIGIT 2000, a two stage interpolation filter is implemented. In the first stage, an interpolation filter is used, which converts the YUV 4:1:1 standard into the YUV 4:2:2 standard.

In the second stage, the interpolation is from the YUV 4:2:2 to YUV 4:4:4.

In the case of YUV 4:2:2 input, only the second stage is necessary.

Refer to I²C registers <06>DELAYU, <10>UVFRM3, and <10>UVFRM1 to choose the correct interpolation filters (see Fig. 2–2).

2.11. YUV Output Low-pass Filter 4:2:2 and 4:1:1

- Y low-pass filter with 7 selectable cutoff frequencies
- UV low-pass decimation filter 4:4:4 \Rightarrow 4:2:2/4:1:1 with 5 selectable cutoff frequencies

To meet the bandwidth requirements of different video standards, such as 4:2:2 or 4:1:1 at various sampling frequencies, the luma signal (Y) and the chroma signal (UV) can be lowpass filtered. There are 7 different cutoff frequencies selectable for luma, via I²C register <05>LPFLUM and 5 different cutoff frequencies selectable for chroma, via I²C register <07>LPFCHR. The spectra of the luminance filters are shown in Fig. 2–9, and the spectra of the chrominance filters are shown in Fig. 2–10.

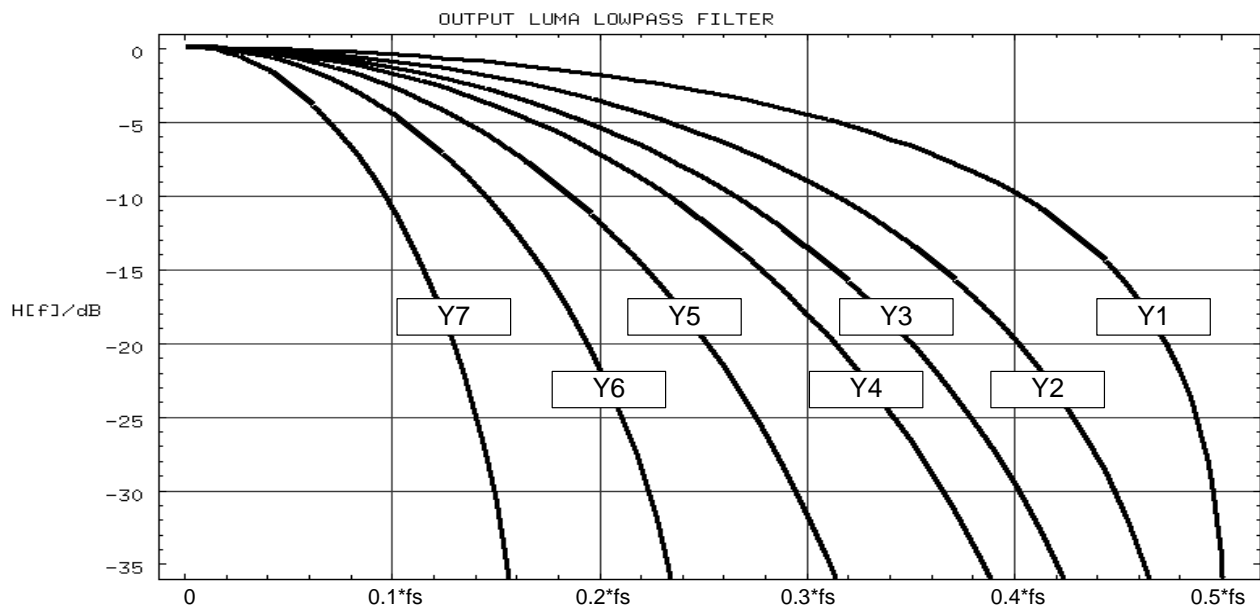

Fig. 2-9: Spectra of selectable luminance filters

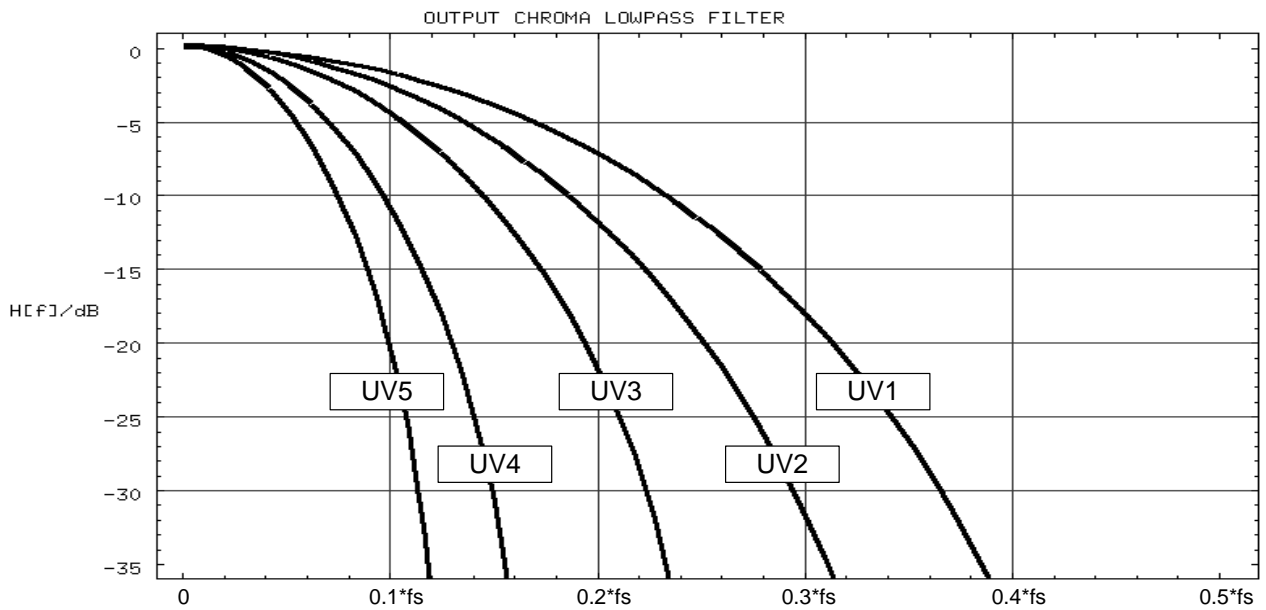

Fig. 2-10: Spectra of selectable chrominance filters

2.12. Selectable RGB/YUV Output Formats

- RGB, 8-bit pure binary (24 bit)
- YUV 4:2:2 (16 bit) for DIGIT 2000, DIGIT 3000, and Philips/Siemens
- YUV 4:1:1 (12 bit) for DIGIT 2000 and Philips/Siemens
- UV format selectable between 2's complement and binary offset

In a first stand alone application, the CIP 3250A can serve as a RGB video analog-to-digital converter to output digital R, G, and B in a pure binary format, 8 bits pure binary per channel, and a sampling rate between 13.5 MHz and 20.25 MHz.

In a second stand alone application, the CIP 3250A can serve as a YUV or RGB (with the matrix switched on) video analog-to-digital converter to output digital YUV, supporting various formats such as YUV 4:1:1 (12 bit) from DIGIT 2000 and Philips, YUV 4:2:2 (16 bit) from DIGIT 2000 and DIGIT 3000, or YUV 4:2:2 (16 bit) industry standard. Additionally, the signed format of the UV signal is programmable between 2's complement and binary offset. A sampling rate between 13.5 MHz and 20.25 MHz can be selected, and the YUV output data can be low pass filtered.

In a DIGIT 2000 environment, the CIP 3250A can process either RGB or YUV signals from the analog Input, mix it with the digital YUV Input data – controlled by the Fast Blank input, and generate low pass filtered output data in the YUV 4:1:1 (12 bit) DIGIT 2000 format. A sampling rate locked to the color subcarrier frequency (4*fsc) for the NTSC or PAL video standard has to be used.

In a DIGIT 3000 environment, the CIP 3250A can process either RGB or YUV signals from the analog input, mix it with the digital YUV input data – controlled by the Fast Blank input, and generate low pass filtered output data in the YUV 4:2:2 (16 bit) DIGIT 3000 format. Additionally, the signed format of the UV signal is programmable between 2's complement and binary offset. The sampling rate is derived from the VPC 320x and ranges from 13.5 to 20.25 MHz for all of the video standards.

The U and V chrominance samples are transmitted in multiplex operation. Depending on the application, the CIP 3250A provides the following different output formats of the YUV signals (selectable via I²C-Bus):

- 4:1:1 orthogonal output format for DIGIT 3000 applications
- 4:2:2 orthogonal output format for DIGIT 3000 applications
- 4:1:1 output format for standard DIGIT 2000 applications
- 4:2:2 output format for DIGIT 2000 applications

Refer to I²C registers <15> to <16> to select the desired output format. Additionally, the CIP 3250A provides conversion of ITURY (luma) to DIGIT 2000 Y (luma) output black levels, selectable via I²C register <16>ADD16Q.

A programmable two-dimensional active video signal (AVO) allows the write control of external video memory directly. The characteristic of the YUV output is selectable between open-drain or push-pull.

Table 2–3: Digital output selection

<15> YUVO	<15> MOD411ON	<15> IND	<15> UVSW	<15> DTI	Digital Output Format
1	1	0	0	0	DIGIT 2000 4:1:1
1	1	1	0	0	orthogonal 4:1:1
1	0	0	1	1	DIGIT 2000 4:2:2
1	0	1	0	0	DIGIT 3000 4:2:2
0	0	0	0	0	4:4:4

2.12.1. DIGIT 2000 4:1:1 Output Format

The DIGIT 2000 4:1:1 output format is shown in Tables 2–4 and 2–5. A control signal for the chroma multiplex is transmitted during the vertical blanking interval (see Section 2.9.1.).

Table 2–4: Bit map of DIGIT 2000 4:1:1 format

Luma Chroma	Y ₁	Y ₂	Y ₃	Y ₄
C ₃ , C ₇	V ₂ ³	V ₂ ⁷	U ₁ ³	U ₁ ⁷
C ₂ , C ₆	V ₂ ²	V ₂ ⁶	U ₁ ²	U ₁ ⁶
C ₁ , C ₅	V ₂ ¹	V ₂ ⁵	U ₁ ¹	U ₁ ⁵
C ₀ , C ₄	V ₂ ⁰	V ₂ ⁴	U ₁ ⁰	U ₁ ⁴

Note: U_x^Y x = pixel number and y = bit number

Table 2–5: Sampling raster of DIGIT 2000 4:1:1 format

Luma Chroma	Y ₁	Y ₂	Y ₃	Y ₄	Y ₅
line 1	V _{2L}	V _{2M}	U _{1L}	U _{1M}	V _{6L}
line 2	U _{xM}	V _{3L}	V _{3M}	U _{2L}	U _{2M}
line 3	U _{xL}	U _{xM}	V _{4L}	V _{4M}	U _{3L}
line 4	V _{1M}	U _{xL}	U _{xM}	V _{5L}	V _{5M}
line 5	V _{2L}	V _{2M}	U _{1L}	U _{1M}	V _{6L}

Note: U_{xy} x = pixel number and y = LSB/MSB nibble pixel no. X indicates an invalid sample at the beginning of the line

2.12.2. DIGIT 2000 4:2:2 Output Format

In the DIGIT 2000 4:2:2 output format, the U and V samples are non-orthogonal (calculated from adjacent pixel, e.g. line n starts with a V pixel and line (n+1) starts with a U pixel (see Table 2–6).

Table 2–6: DIGIT 2000 4:2:2 output format

Luma Chroma	Y ₁	Y ₂	Y ₃	Y ₄
C ₇	V ₂ ⁷	U ₁ ⁷	V ₄ ⁷	U ₃ ⁷
C ₆	V ₂ ⁶	U ₁ ⁶	V ₄ ⁶	U ₃ ⁶
C ₅	V ₂ ⁵	U ₁ ⁵	V ₄ ⁵	U ₃ ⁵
C ₄	V ₂ ⁴	U ₁ ⁴	V ₄ ⁴	U ₃ ⁴
C ₃	V ₂ ³	U ₁ ³	V ₄ ³	U ₃ ³
C ₂	V ₂ ²	U ₁ ²	V ₄ ²	U ₃ ²
C ₁	V ₂ ¹	U ₁ ¹	V ₄ ¹	U ₃ ¹
C ₀	V ₂ ⁰	U ₁ ⁰	V ₄ ⁰	U ₃ ⁰

Note: U_x^Y x = pixel number and y = bit number

2.12.3. DIGIT 3000 Orthogonal 4:2:2 Output Format

The DIGIT 3000 orthogonal 4:2:2 output format is compatible to the industry standard. The U and V samples are skew corrected and interpolated to an orthogonal sampling raster, e.g. every line starts with the current U pixel (see Table 2–7).

Table 2–7: Orthogonal 4:2:2 output format

Luma Chroma	Y ₁	Y ₂	Y ₃	Y ₄
C ₇	U ₁ ⁷	V ₁ ⁷	U ₃ ⁷	V ₃ ⁷
C ₆	U ₁ ⁶	V ₁ ⁶	U ₃ ⁶	V ₃ ⁶
C ₅	U ₁ ⁵	V ₁ ⁵	U ₃ ⁵	V ₃ ⁵
C ₄	U ₁ ⁴	V ₁ ⁴	U ₃ ⁴	V ₃ ⁴
C ₃	U ₁ ³	V ₁ ³	U ₃ ³	V ₃ ³
C ₂	U ₁ ²	V ₁ ²	U ₃ ²	V ₃ ²
C ₁	U ₁ ¹	V ₁ ¹	U ₃ ¹	V ₃ ¹
C ₀	U ₁ ⁰	V ₁ ⁰	U ₃ ⁰	V ₃ ⁰

Note: U_x^Y x = pixel number and y = bit number

2.12.4. Orthogonal 4:1:1 Output Format

The orthogonal 4:1:1 output format is compatible to the industry standard. The U and V samples are skew corrected and interpolated to an orthogonal sampling raster (see Table 2–8).

Table 2–8: 4:1:1 orthogonal output format

Luma Chroma	Y ₁	Y ₂	Y ₃	Y ₄
C ₃ , C ₇	U ₁ ⁷	U ₁ ⁵	U ₁ ³	U ₁ ¹
C ₂ , C ₆	U ₁ ⁶	U ₁ ⁴	U ₁ ²	U ₁ ⁰
C ₁ , C ₅	V ₁ ⁷	V ₁ ⁵	V ₁ ³	V ₁ ¹
C ₀ , C ₄	V ₁ ⁶	V ₁ ⁴	V ₁ ²	V ₁ ⁰

Note: U_x^y x = pixel number and y = bit number

2.12.5. YUV Output Levels

The Y output black level of the CIP 3250A can be converted from ITU-R 601 Standard (digital 16) to DIGIT 2000 Standard (digital 32) via I²C register <16>ADD16Q.

2.13. I/O Code Levels

- ITU-R/DIGIT 3000 code levels:
Y or RGB = 16...240, clamp level = 16
UV = ±112, bias level = 0
- or DIGIT 2000 code levels:
Y = 32...127, clamp level = 32
UV = ±127, bias level = 0

2.14. AVO Active Video Output

In a DIGIT 3000 system environment, the AVO signal is equivalent to the delayed AVI signal. It signalizes valid video data and chroma multiplex at the output of the CIP 3250A. Furthermore, the AVO signal can be used to control the write enable of a frame memory. The polarity of the AVO signal is programmable via I²C register <10>AVOINV.

In a DIGIT 2000 system environment, the AVO signal can be programmed via I²C registers <23> to <26> to define a window of valid video data at the output of the CIP 3250A (see Fig. 2–11).

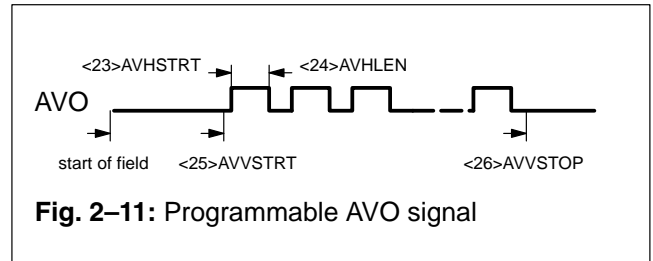

Fig. 2–11: Programmable AVO signal

Select the desired mode via I²C register <17>AVINT. If the AVO signal is derived from the AVI signal, the I²C registers <22>AVDLY can be used to compensate internal processing delays of the CIP 3250A.

I²C register <22>AVPR can be used to precede the AVO signal in relation to the RGB/YUV data output up to 3 clocks.

2.15. PRIO Interface

- real-time bus arbitration for 8 sources in DIGIT 3000 picture bus.

Up to eight digital YUV or RGB sources (main decoder, PIP, OSD, Text, etc.) may be selected in real-time by means of a 3 bit priority bus. Thus, a pixelwise bus arbitration and source switching is possible. It is essential that all YUV-sources are synchronous and orthogonal.

In general, each source (= master) has its own YUV bus request. This bus request may either be software or hardware controlled, i.e. a fast blank signal. Data collision is avoided by a bus arbiter that provides the individual bus acknowledge, in accordance to a user defined priority.

Each master sends a bus request with its individual priority ID onto the PRIO-bus and immediately reads back the bus status. Only in case of positive arbitration (send-PRIO-ID = read-PRIO-ID), the RGB/YUV outputs become active and the data is send. PRIO requests must be enabled by I²C register <14>PRIOEN.

The requests asserted by the CIP 3250A may be generated by two different sources, which are selectable by I²C register <09>PRIOSRC. With the first source, the CIP 3250A asserts requests only when the AVO signal is active, else RGB/YUV outputs are tristated. With the second source, the CIP 3250A asserts continuous requests where the YUV data are forced to “clamp/bias level data” (see section 2.13.) during the time that the AVO signal is inactive.

If only one source is connected to the YUV bus, the outputs GL, RC, and B may drive the bus during a full clock cycle. This can be selected by I²C register <06>HALF-OUT. If more than one source is connected to the YUV bus, the output drivers must be switched to driving only during the first half of clock cycle to avoid bus collision. In the last case, the layout of the PCB must consider that

data on YUV bus must be kept dynamically for a half clock cycle. Thus, capacitvie coupling from other signals to YUV bus must be avoided or reduced to a tolerable minimum.

This procedure has many features which have an impact on the appearance of a TV picture:

- real-time bus arbitration (PIP, OSD, ...)
- priorities are software configurable
- different coefficients for different sources

2.16. I²C Serial Bus Control

Communication between the CIP 3250A and the external controller is done via I²C bus. The CIP 3250A has an I²C bus slave interface and uses I²C clock synchronization to slow down the interface if required. The I²C bus interface uses one level of subaddressing: one I²C bus address is used to address the IC and a subaddress selects one of the internal registers.

The registers of the CIP 3250A have 8 bit data size. All registers are writeable (except subaddress hex27) and readable as well. Register bits of parameter addresses, which are marked with an X in the description field of the register table, must be set to zero. All registers are initialized to zero with reset.

Figure 2–12 shows I²C bus protocols for read and write operations of the interface.

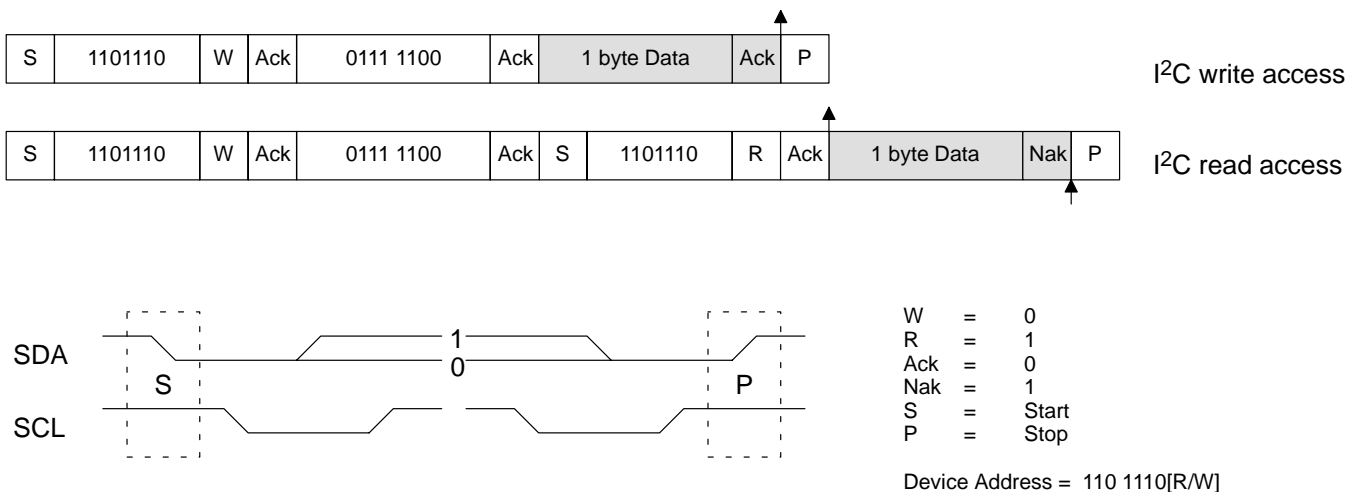

Fig. 2–12: I²C Bus Protocol

Table 2–9: The I²C-bus addresses of the CIP 3250A – Device Address: 6E Hex (7 bit, R/W bit omitted, see Sec. 2.16.)

Bit No. Sub. Addr.	MSB 7	6	5	4	3	2	1	LSB 0	
00	NOISSU noise shaping of U		SATU saturation multiplier of U						
	-		32						
01	NOISSV noise shaping of V		SATV saturation multiplier of V						
	-		32						
02	NOISSY noise shaping of Y		SATY contrast multiplier of Y						
	-		32						
03	BRY brightness correction of Y								
	0								
04	CBSON CTBRST block enable	SMODE saturation mode	CLSEL clamping offset for Y	MAON matrix block enable	SKWON skew correction enable	SKWCBS skew filter mode	ATST testbits		
	1	0	0	1	-	-	0		
05	LPFLUM luma low pass filter selection								
	-								
06	PASSYUV soft mixer control	D2KIN input amplifier of digital YUVin	DELAYU UV format of YUVin	HALFOUT output drive duration	CYLUM1 Y low pass filter offset correction 1	CYLUM2 Y low pass filter offset correction 2	CYCHR1 UV low pass filter offset correction 1	CYCHR2 UV low pass filter offset correction 2	
	0	-	-	0	-	-	-	-	
07	FSYINV polarity FSY	LPFCHR chroma low pass filter selection							
	-	-							
08	TESTLUY test y channel		TESTCHU test u channel		TESTCHV test v channel		TESTFBL test fbl channel	ICLPTST test fbl clamp and IDDQ test	
	0		0		0		0	0	
09	TESTCLP test clamping	YUV analog input select	SE_4_8Q analog gain control	SELAMP analog gain control		CLMPOFS RGB clamping offset	AVODIS disable ACVOUT	PRIOSRC Source for PRIO request	
	0	0	0	0		0	-	1	
10	AVOINV polarity AVO	AVIINV polarity AVI	SECAM delay for SECAM	DL1ON delay of YUVin	UVBINCON UV sign of YUVin	UVFRM3 UV format of YUVin	UVFRM1 UV format of YUVin	YLEVEL convert Y format	
	-	-	-	-	-	-	-	-	
11	FBLTEN Fast Blank test	PASSRGB soft mixer control	FBLOFF Fast Blank offset correction						
	0	1	31						
12	MIXAMP amplification of Fast Blank amplitude				SELDLY adjust delay of RGB/YUV-path		SELLIN select soft mixer	CTRLDLY delay control	
	1				1		0	0	
13	OVR override value for PRIO-interface								
	-								
14	PRIOEN access to Picture Bus	PRIOID set PRIO priority			PUDIS disable pull up of YUV/RBG output	LOAD adjust load strength of Picture Bus and PRIO bus			
	1	-			-	-			
15	UVSW UV multiplex of YUV output	DTI UV output format	IND UV output format	BINO UV sign of output format	YUVO select RGB/YUV output format	MOD411ON UV output format	CDEL select UV output sample from 4:4:4		
	-	-	-	-	-	-	-		
16	FBLCLP static Fast Blank	FBLDEL delay Fast Blank vs. analog RGB/YUV		YDEL adjust Y output delay		ADD16Q black level of Y output	DL422Y additional Y output delay	DL422C additional UV output delay	
	0	0		-		-	-	-	
17	SYNCIN UV sync control of YUVin	SYNCOUT UV sync control of YUV output	NEGCLK select active clockedge	AVINT AVO control	PXSKWON pixel skew correction	P72BEN 72 bit data bypass	D2KSYNC sync input at FSY-pin	SYNCSIM H-sync, V-sync input	
	-	-	-	-	-	-	-	-	

Table 2–9: The I²C-bus addresses of the CIP 3250A, continued

Bit No. Sub. Addr.	MSB 7	6	5	4	3	2	1	LSB 0
18	CLPSTRT start of clamping window							
	-							
19	CLPSTOP stop of clamping window							
	-							
20	SKEWLAT latch time for sub-pixel skew value							
	-							
21	DL2 fifo delay adjust for RGB/YUV-path							
	-							
22	AVPR delay between YUV output and AVO		AVDLY delay AVI to AVO to compensate CIP 3250 A processing delay					
	-		-					
23	AVHSTRT horizontal start of AVO							
	-							
24	AVHLEN horizontal length of AVO							
	-							
25	AVVSTRT vertical start of AVO							
	-							
26	AVVSTOP vertical stop of AVO							
	-							
27					FBLSTAT static FBL read	FBLRISE dynamic FBL read rising edge	FBLFALL dynamic FBL read falling edge	FBLHIGH dynamic FBL read high level
	-				-	-	-	-

Table 2–10: I²C-Bus operation – Device Address: 6E Hex (7 bit, R/W bit omitted, see Sec. 2.16.)

Sub-Address (decimal)	Label	Bit No. (LSB = 0)	Typical Operation Value	Function
I²C registers for ADC and CLAMPING				
09	YUV	6	0	analog input select 0 = RGB 1 = YUV
18	CLPSTRT	7–0	30	start of clamping window (0...255)*2 clocks after H-sync (see Fig. 2–13)
19	CLPSTOP	7–0	50	stop of clamping window (0...255)*2 clocks after H-sync (see Fig. 2–13) [note: – maximum window size: 64 sample clocks] [– minimum window size: 6 sample clocks]
09	CLMPOFS	2	0	RGB clamping offset 0 = +16 (digital) 1 = +8 (digital)
04	CLSEL	5	0	Y (luma) black level adjust at RGB-path 0 = convert Y (luma) black level from digital 16 to 32 (DIGIT 2000) 1 = Y (luma) black level at digital 16 (ITU-R 601 Standard)
09	SELAMP	4–3	0	analog gain control 0 = 1/8 1 = 1/16 2 = 1/32
09	SE_4_8Q	5	0	analog gain control 0 = 1/8 1 = 1/4
I²C registers for MATRIX				
04	MAON	4	1	matrix block 0 = matrix off (YUV input or RGB bypass) 1 = matrix on (RGB to Y(R–Y)(B–Y))
I²C registers for CONTRAST / BRIGHTNESS / SATURATION				
04	CBSON	7	1	CTBRST block 0 = bypassed (for dig. RGB bypass only (<04>MAON=0)) 1 = on
03	BRY	7–0	0	brightness correction of Y (luma) in CTBRST block Y + (–128...127)
02	SATY	5–0	32	contrast multiplier of Y (luma) in CTBRST block Y * (0...63)/32
02	NOISSY	7,6	0	noise shaping of Y (luma) in CTBRST block 0 = off (rounding is activated) 2 = 1 bit error diffusion 3 = 2 bit error diffusion
00	SATU	5–0	32	saturation multiplier of U (chroma) in CTBRST block U * (0...63)/32
00	NOISSU	7,6	0	noise shaping of U (chroma) in CTBRST block 0 = off (rounding is activated) 2 = 1 bit error diffusion 3 = 2 bit error diffusion
01	SATV	5–0	32	saturation multiplier of V (chroma) in CTBRST block V * (0...63)/32
01	NOISSV	7,6	0	noise shaping of V (chroma) in CTBRST block 0 = off (rounding is activated) 2 = 1 bit error diffusion 3 = 2 bit error diffusion
04	SMODE	6	0	saturation mode of UV (chroma) in CTBRST block 0 = internal PAL (U * 0.5, V * 0.875) 1 = external (U * 1, V * 1)

Table 2–10: I²C-Bus operation, continued

Sub-Address (decimal)	Label	Bit No. (LSB = 0)	Typical Operation Value	Function
I²C registers for OUTPUT FORMATTER				
15	YUVO	3	1	select video component output format 0 = output formater off (i.e. RGB or YUV output with format 4:4:4) 1 = output formater on (i.e. YUV output with format 4:2:2 or 4:1:1)
16	ADD16Q	2	1	black level of Y (luma) output 0 = Convert Y black level at output from ITU-R 601 Standard to DIGIT 2000 Standard (digital 32) 1 = Y black level at output unchanged
15	MOD411ON	2	0	UV (chroma) output format 0 = 4:2:2 1 = 4:1:1
15	BINO	4	0	UV (chroma) sign of output format 0 = two's complement 1 = binary offset
15	CDEL	1–0	0	select UV (chroma) output sample from 4:4:4 format (0...3)
15	IND	5	1	UV (chroma) output format 0 = DIGIT 2000 1 = DIGIT 3000 / orthogonal
15	UVSW	7	0	UV (chroma) multiplex of output format 0 = DIGIT 3000 4:2:2 / DIGIT 2000 4:1:1 / orthogonal 4:1:1 1 = DIGIT 2000 4:2:2
15	DTI	6	0	UV (chroma) output format 0 = DIGIT 3000 4:2:2 / DIGIT 2000 4:1:1 / orthogonal 4:1:1 1 = DIGIT 2000 4:2:2
16	YDEL	4–3	0	adjust Y (luma) output delay in reference to UV (chroma) output (0...3) clocks
16	DL422Y	1	0	additional Y (luma) output delay (0...1) clocks (DIGIT 3000 4:2:2 / MAC)
16	DL422C	0	0	additional UV (chroma) output delay (0...1) clocks (DIGIT 3000 4:2:2 / MAC)
I²C registers for SKEW FILTER				
04	SKWON	3	0	skew correction 0 = off 1 = on
04	SKWCBS	2	1	skew filter active for 0 = DIGIT 2000 pixel orthogonalization 1 = DIGIT 3000 pixel orthogonalization
20	SKEWLAT	7–0	0	latch time for sub-pixel skew value (from FSY-/SKEW-protocol) to adjust the processing delays of video data to H-sync (see Fig. 2–13) (0...255)*2 clocks
I²C registers for PRIO				
14	PRIOEN	7	1	access to Picture Bus (GL, RC, B output) 0 = disabled (Picture Bus is tristate) 1 = enabled (access to Picture Bus possible)
09	PRIOSRC	0	1	Source for PRIO request 0 = PRIO request only if AVO is active 1 = PRIO request always independent of AVO
14	PRIOD	6–4	7	set PRIO priority (0...7)
13	OVR	7–0	0	override value for PRIO-interface

Table 2–10: I²C-Bus operation, continued

Sub-Address (decimal)	Label	Bit No. (LSB = 0)	Typical Operation Value	Function
I ² C registers for SOFT MIX				
11	PASSRGB	6	1	soft mixer control 0 = analog RGB/YUV-path passed only 1 = mixing controlled by Fast Blank (if <11>PASSYUV=0)
06	PASSYUV	7	0	soft mixer control 0 = mixing controlled by Fast Blank (if <11>PASSRGB=1) 1 = digital YUVin-path passed only (if <11>PASSRGB=1)
16	FBLCLP	7	0	enable static operation of Fast Blank 0 = Fast Blank derived from analog FBL input 1 = static Fast Blank (FBL = 31)
11	FBLOFF	5–0	32	Fast Blank offset correction FBL – (0...63)
16	FBLDEL	6–5	0	delay Fast Blank vs. analog RGB/YUV input 3 = –1 clocks 0 = 0 clocks 1 = 1 clocks 2 = 2 clocks
12	MIXAMP	7–4	1	amplification of Fast Blank amplitude FBL * (–4...4) [note: value 0 invalid, use <06>PASSYUV or <11>PASSRGB for static operation of soft mixer instead]
12	CTRLDLY	0	0	delay control of analog RGB/YUV data in relation to digital YUV data 0 = statically (by value of <12>SELDLY) 1 = dynamically (by nonlinear mixer)
12	SELDLY	3–2	1	delay value for analog RGB/YUV data in relation to digital YUV data (<12>CTRLDLY=0) 0 = –1 pixel 1 = 0 pixel 2 = +1 pixel
12	SELLIN	1	0	select soft mixer type 0 = linear mixer 1 = nonlinear mixer
27	FBLSTAT	3		fast blank input : 1 = high, 0 = low (see Fig. 2–5)
27	FBLRISE	2		set with an rising edge at fast blank input reset at read of <27>
27	FBLFALL	1		set with an falling edge at fast blank input reset at read of <27>
27	FBLHIGH	0		dynamic FBL read high level

Table 2–10: I²C-Bus operation, continued

Sub-Address (decimal)	Label	Bit No. (LSB = 0)	Typical Operation Value	Function
I ² C registers for ACTIVE VIDEO SIGNAL				
10	AVIINV	6	0	polarity of AVI signal 0 = active video during AVI is high (if <17>AVINT = 0) 1 = active video during AVI is low (if <17>AVINT = 0)
10	AVOINV	7	0	polarity of AVO signal 0 = AVO is high active 1 = AVO is low active
22	AVDLY	5–0	32	delay from AVI (active video in) to AVO to compensate CIP 3250A processing delays (if <17>AVINT = 0) (0...63) + 14 – <22>AVPR clocks (if <10>DL1ON=0) (0...63) + 92 – <22>AVPR clocks (if <10>DL1ON=1)
22	AVPR	7–6	0	delay between AVO and YUV output AVO precedes YUV output by AVPR (0...3) clocks
17	AVINT	4	0	AVO (active video out) 0 = derived from AVI (active video in) 1 = generated internally (see <23>AVHSTRT, <24>AVHLEN, <25>AVVSTRT, <26>AVVSTOP)
23	AVHSTRT	7–0	0	horizontal start of AVO after H-sync if <17>AVINT = 1 (0...255)*8 + 11 – <22>AVPR clocks (see Fig. 2–13)
24	AVHLEN	7–0	0	horizontal length of AVO if <17>AVINT = 1 (0...255)*8 clocks
25	AVVSTRT	7–0	0	vertical start of AVO if <17>AVINT = 1 (0...255)*4 lines
26	AVVSTOP	7–0	0	vertical stop of AVO if <17>AVINT = 1 (0...255)*4 lines

Table 2–10: I²C-Bus operation, continued

Sub-Address (decimal)	Label	Bit No. (LSB = 0)	Typical Operation Value	Function
I²C registers for ADJUSTABLE LOWPASS FILTER				
05	LPFLUM	7–0	0	Y luma low pass filter selection 0 = bypass 128 = Y1 (<06>CYLUM1=0, <06>CYLUM2=0, increment <16>YDEL by 1) 192 = Y2 (<06>CYLUM1=0, <06>CYLUM2=0, increment <16>YDEL by 1) 224 = Y3 (<06>CYLUM1=0, <06>CYLUM2=0, increment <16>YDEL by 2) 240 = Y4 (<06>CYLUM1=0, <06>CYLUM2=0, increment <16>YDEL by 2) 241 = Y5 (<06>CYLUM1=0, <06>CYLUM2=0, increment <16>YDEL by 2) 249 = Y6 (<06>CYLUM1=0, <06>CYLUM2=0, increment <16>YDEL by 2) 255 = Y7 (<06>CYLUM1=0, <06>CYLUM2=0, increment <16>YDEL by 2) [note: <16>YDEL has to be incremented to match group delays]
06	CYLUM1	3	0	Y (luma) low pass filter offset correction 1 0 = off 1 = on
06	CYLUM2	2	0	Y (luma) low pass filter offset correction 2 0 = off 1 = on
07	LPFCHR	6–0	0	UV (chroma) low pass filter selection 0 = bypass 96 = UV1 (<06>CYCHR1=0, <06>CYCHR2=0) 97 = UV2 (<06>CYCHR1=0, <06>CYCHR2=0) 113 = UV3 (<06>CYCHR1=0, <06>CYCHR2=0) 125 = UV4 (<06>CYCHR1=0, <06>CYCHR2=0) 127 = UV5 (<06>CYCHR1=0, <06>CYCHR2=0)
06	CYCHR1	1	0	UV (chroma) low pass filter offset correction 1 0 = off 1 = on
06	CYCHR2	0	0	UV (chroma) low pass filter offset correction 2 0 = off 1 = on
I²C registers for DELAY2 (DL2)				
17	PXSKWON	3	1	pixel skew correction (see section 2.5.) 0 = off [note: delay adapted every field, see Fig. 2–15] 1 = on [note: delay adapted every line, see Fig. 2–14]
21	DL2	7–0	69	delay adjust for RGB to YUV-path (see section 2.5.) (0...255)*2 + 2 clocks delay to write DL2–FIFO if <17>PXSKWON = 1 (48...212) clocks delay to read DL2–FIFO if <17>PXSKWON = 0
I²C registers for DELAY1 (DL1)				
10	SECAM	5	0	delay of digital YUVin (SECAM mode) 0 = see <10>DL1ON 1 = UV: 2 clocks, Y: 76 clocks (set <10>DL1ON = 0)
10	DL1ON	4	1	delay of digital YUVin (set <10>SECAM = 0) 0 = 2 clocks 1 = 80 clocks

Table 2–10: I²C-Bus operation, continued

Sub-Address (decimal)	Label	Bit No. (LSB = 0)	Typical Operation Value	Function
I ² C registers for INPUT FORMATTER				
06	D2KIN	6	0	input current source of digital YUVin 0 = DIGIT 3000 (current source off) 1 = DIGIT 2000 (current source active, see Fig. 3–8)
10	YLEVEL	0	0	DIGIT 2000 Y (luma) format conversion to ITU-R 601 Standard 0 = off 1 = on
10	UVBINCON	3	0	UV (chroma) sign of YUVin 0 = two's complement 1 = binary offset
06	DELAYU	5	1	UV (chroma) format of YUVin 0 = DIGIT 2000 4:2:2 / DIGIT 2000 4:1:1 1 = DIGIT 3000 4:2:2 / MAC
10	UVFRM3	2	1	UV (chroma) format of YUVin 0 = DIGIT 2000 4:1:1 / DIGIT 2000 4:2:2 / MAC 1 = DIGIT 3000 4:2:2
10	UVFRM1	1	0	UV (chroma) format of YUVin 0 = DIGIT 2000 4:2:2 / DIGIT 3000 4:2:2 / MAC 1 = DIGIT 2000 4:1:1

Sub-Address (decimal)	Label	Bit No. (LSB = 0)	Typical Operation Value	Function																																																																				
I ² C registers for OUTPUT CONTROL																																																																								
06	HALFOUT	4	0	Output drive duration 0 = output active a full clock cycle (only one IC on Picture Bus) 1 = output active half a clock cycle (more than one IC on Picture Bus)																																																																				
09	AVODIS	1	0	disable AVO pin 0 = AVO pin is active 1 = AVO pin is tristate																																																																				
14	PUDIS	3	0	disable pull-up transistors at GL, RC, and B output pins 0 = pull-up on (output is in push-pull mode) 1 = pull-up off (output is in open drain mode)																																																																				
14	LOAD	2-0	0	<p>adjust load of AVO, GL, RC, B and PRIO (select lowest possible load to keep electromagnetic radiation and noise at A/D-Converter low)</p> <table border="0"> <tr> <td>LOAD</td> <td colspan="4">GL, RC, B, and AVO outputs</td> </tr> <tr> <td></td> <td colspan="2">@PVDD = 5 Volt</td> <td colspan="2">@PVDD = 3.3 Volt</td> </tr> <tr> <td>000</td> <td>C_{Load} ≤ 100 pF</td> <td>I_{Load} ≤ 3.4mA</td> <td>C_{Load} ≤ 50 pF</td> <td>I_{Load} ≤ 3.0mA</td> </tr> <tr> <td>001</td> <td>C_{Load} ≤ 55 pF</td> <td>I_{Load} ≤ 2.3mA</td> <td>C_{Load} ≤ 28 pF</td> <td>I_{Load} ≤ 1.5mA</td> </tr> <tr> <td>010</td> <td>C_{Load} ≤ 37 pF</td> <td>I_{Load} ≤ 1.5mA</td> <td>C_{Load} ≤ 20 pF</td> <td>I_{Load} ≤ 1.0mA</td> </tr> <tr> <td>011</td> <td>C_{Load} ≤ 28 pF</td> <td>I_{Load} ≤ 1.2mA</td> <td>C_{Load} ≤ 16 pF</td> <td>I_{Load} ≤ 0.8mA</td> </tr> <tr> <td>100</td> <td>C_{Load} ≤ 23 pF</td> <td>I_{Load} ≤ 0.9mA</td> <td>C_{Load} ≤ 12 pF</td> <td>I_{Load} ≤ 0.6mA</td> </tr> <tr> <td>101</td> <td>C_{Load} ≤ 18 pF</td> <td>I_{Load} ≤ 0.7mA</td> <td>C_{Load} ≤ 10 pF</td> <td>I_{Load} ≤ 0.5mA</td> </tr> <tr> <td>110</td> <td>C_{Load} ≤ 14 pF</td> <td>I_{Load} ≤ 0.6mA</td> <td>C_{Load} ≤ 8 pF</td> <td>I_{Load} ≤ 0.4mA</td> </tr> <tr> <td>111</td> <td colspan="2">pins tristate</td> <td colspan="2">pins tristate</td> </tr> </table> <table border="0"> <tr> <td>LOAD</td> <td>PRIO bus</td> </tr> <tr> <td>000</td> <td>I_{SINK} ≤ 12mA</td> </tr> <tr> <td>001</td> <td>I_{SINK} ≤ 12mA</td> </tr> <tr> <td>010</td> <td>I_{SINK} ≤ 9mA</td> </tr> <tr> <td>011</td> <td>I_{SINK} ≤ 9mA</td> </tr> <tr> <td>100</td> <td>I_{SINK} ≤ 6mA</td> </tr> <tr> <td>101</td> <td>I_{SINK} ≤ 6mA</td> </tr> <tr> <td>110</td> <td>I_{SINK} ≤ 3mA</td> </tr> <tr> <td>111</td> <td>I_{SINK} ≤ 3mA</td> </tr> </table> <p>NOTE: Total C_{LOAD} at pins GL, RC, B, AVO, and PRIO must not exceed 2 nF. C_{Load} = max. load capacitance for AVO C_{Load} = max. load capacitance for GL, RC, and B at push-pull mode 12C:<14> PUDIS = 0 I_{Load} = max. sink current for GL, RC, and B at open drain mode 12C:<14> PUDIS = 1</p>	LOAD	GL, RC, B, and AVO outputs					@PVDD = 5 Volt		@PVDD = 3.3 Volt		000	C _{Load} ≤ 100 pF	I _{Load} ≤ 3.4mA	C _{Load} ≤ 50 pF	I _{Load} ≤ 3.0mA	001	C _{Load} ≤ 55 pF	I _{Load} ≤ 2.3mA	C _{Load} ≤ 28 pF	I _{Load} ≤ 1.5mA	010	C _{Load} ≤ 37 pF	I _{Load} ≤ 1.5mA	C _{Load} ≤ 20 pF	I _{Load} ≤ 1.0mA	011	C _{Load} ≤ 28 pF	I _{Load} ≤ 1.2mA	C _{Load} ≤ 16 pF	I _{Load} ≤ 0.8mA	100	C _{Load} ≤ 23 pF	I _{Load} ≤ 0.9mA	C _{Load} ≤ 12 pF	I _{Load} ≤ 0.6mA	101	C _{Load} ≤ 18 pF	I _{Load} ≤ 0.7mA	C _{Load} ≤ 10 pF	I _{Load} ≤ 0.5mA	110	C _{Load} ≤ 14 pF	I _{Load} ≤ 0.6mA	C _{Load} ≤ 8 pF	I _{Load} ≤ 0.4mA	111	pins tristate		pins tristate		LOAD	PRIO bus	000	I _{SINK} ≤ 12mA	001	I _{SINK} ≤ 12mA	010	I _{SINK} ≤ 9mA	011	I _{SINK} ≤ 9mA	100	I _{SINK} ≤ 6mA	101	I _{SINK} ≤ 6mA	110	I _{SINK} ≤ 3mA	111	I _{SINK} ≤ 3mA
LOAD	GL, RC, B, and AVO outputs																																																																							
	@PVDD = 5 Volt		@PVDD = 3.3 Volt																																																																					
000	C _{Load} ≤ 100 pF	I _{Load} ≤ 3.4mA	C _{Load} ≤ 50 pF	I _{Load} ≤ 3.0mA																																																																				
001	C _{Load} ≤ 55 pF	I _{Load} ≤ 2.3mA	C _{Load} ≤ 28 pF	I _{Load} ≤ 1.5mA																																																																				
010	C _{Load} ≤ 37 pF	I _{Load} ≤ 1.5mA	C _{Load} ≤ 20 pF	I _{Load} ≤ 1.0mA																																																																				
011	C _{Load} ≤ 28 pF	I _{Load} ≤ 1.2mA	C _{Load} ≤ 16 pF	I _{Load} ≤ 0.8mA																																																																				
100	C _{Load} ≤ 23 pF	I _{Load} ≤ 0.9mA	C _{Load} ≤ 12 pF	I _{Load} ≤ 0.6mA																																																																				
101	C _{Load} ≤ 18 pF	I _{Load} ≤ 0.7mA	C _{Load} ≤ 10 pF	I _{Load} ≤ 0.5mA																																																																				
110	C _{Load} ≤ 14 pF	I _{Load} ≤ 0.6mA	C _{Load} ≤ 8 pF	I _{Load} ≤ 0.4mA																																																																				
111	pins tristate		pins tristate																																																																					
LOAD	PRIO bus																																																																							
000	I _{SINK} ≤ 12mA																																																																							
001	I _{SINK} ≤ 12mA																																																																							
010	I _{SINK} ≤ 9mA																																																																							
011	I _{SINK} ≤ 9mA																																																																							
100	I _{SINK} ≤ 6mA																																																																							
101	I _{SINK} ≤ 6mA																																																																							
110	I _{SINK} ≤ 3mA																																																																							
111	I _{SINK} ≤ 3mA																																																																							

Table 2–10: I²C-Bus operation, continued

Sub-Address (decimal)	Label	Bit No. (LSB = 0)	Typical Operation Value	Function
I²C registers for SYNCHRONIZATION				
17	NEGCLK	5	0	select active clockedge for inputs and outputs 0 = all inputs and outputs relate to rising edge at CLK input (DIGIT 3000) 1 = all inputs and outputs relate to falling edge at CLK input (DIGIT 2000)
17	SYNCSIM	0	1	HSYNC, VSYNC input 0 = FSY-/SKEW-protocol (see <17>D2KSYNC) 1 = HSYNC at FSY-pin, VSYNC at AVI-pin (see also <07>FSYINV, <10>AVIINV)
17	D2KSYNC	1	0	
10	AVIINV	6	0	polarity of AVI signal 0 = vertical sync at falling edge of AVI (if <17>SYNCSIM = 1) 1 = vertical sync at rising edge of AVI (if <17>SYNCSIM = 1)
07	FSYINV	7	0	
17	SYNCIN	7	0	UV (chroma) multiplex control of digital YUVin 0 = by AVI (active video in) 1 = by 72 bit data (DIGIT 2000)
17	SYNCOUT	6	0	
17	P72BEN	2	0	72 bit data and clock bypass enable 0 = off 1 = on (DIGIT 2000)

D2KSYNC <17>	SYNCSIM <17>	delay (clocks)
X	1	4
1	0	15
0	0	23

H-sync delay in respect to falling edge of FSY/
SKEW (H-sync is derived from FSY/SKEW)

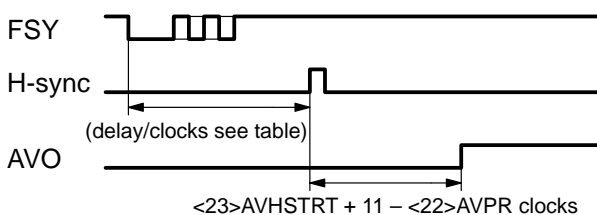

Fig. 2–13: H-sync reference generation

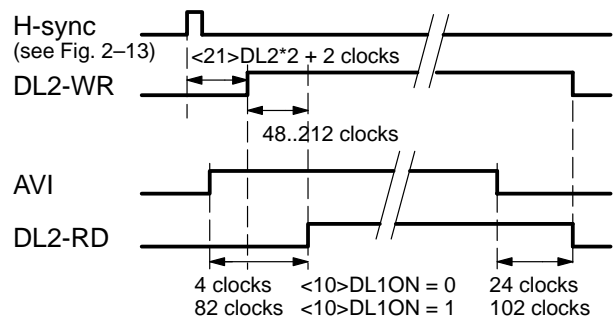

Fig. 2–14: DL2-setup (<17>PXSKWON = 1)

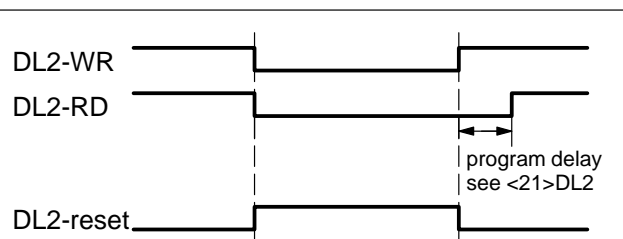

Fig. 2–15: DL2-reset during line 7
(<17>PXSKWON = 0)

3. Specifications

3.1. Outline Dimensions

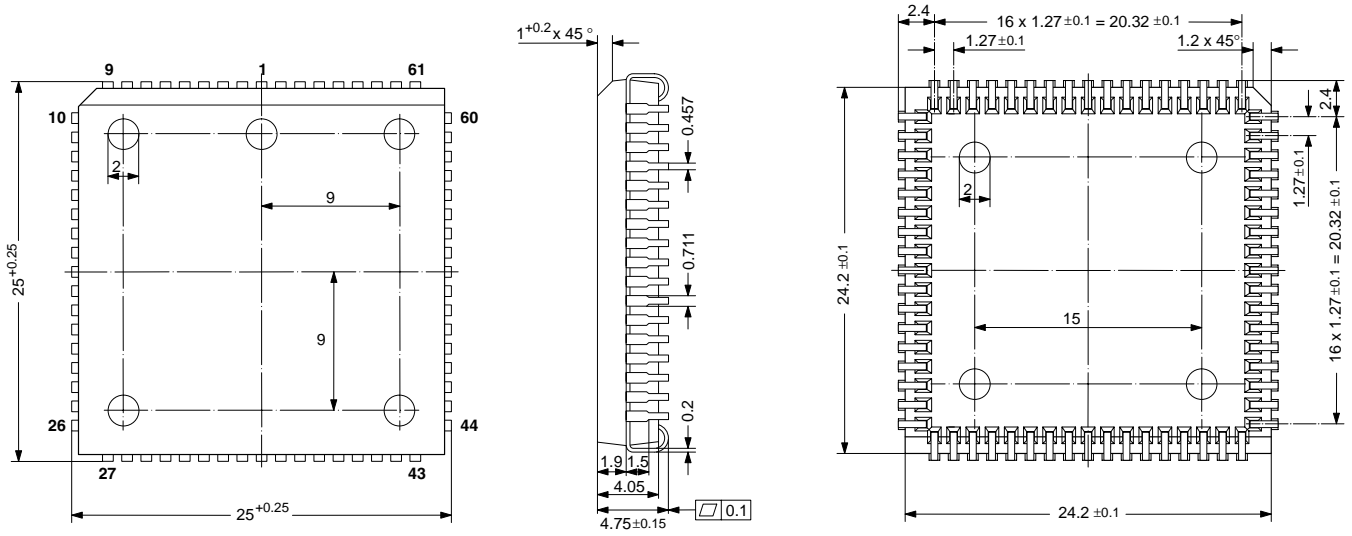

Fig. 3-1:
 68-Pin Plastic Leaded Chip Carrier Package
(PLCC68)
 Weight approximately 4.8 g
 Dimensions in mm

3.2. Pin Connections and Short Descriptions

NC = not connected; leave vacant

LV = if not used, leave vacant

X = obligatory; connect as described in circuit diagram

DVSS = if not used, connect to DVSS

AVSS = connect to AVSS

Pin No. PLCC 68-pin	Connection (if not used)	Pin Name	Type	Short Description
1	DVSS	STANDBY	IN	Standby connect to ground
2	LV	B7	OUT	Blue Output (MSB)
3	LV	B6	OUT	Blue Output
4	LV	B5	OUT	Blue Output
5	LV	B4	OUT	Blue Output
6	LV	B3	OUT	Blue Output
7	LV	B2	OUT	Blue Output
8	LV	B1	OUT	Blue Output
9	LV	B0	OUT	Blue Output (LSB)
10	LV	GL7	OUT	Green/Luma Output (MSB)
11	LV	GL6	OUT	Green/Luma Output
12	LV	GL5	OUT	Green/Luma Output

Pin No. PLCC 68-pin	Connection (if not used)	Pin Name	Type	Short Description
13	LV	GL4	OUT	Green/Luma Output
14	LV	GL3	OUT	Green/Luma Output
15	LV	GL2	OUT	Green/Luma Output
16	LV	GL1	OUT	Green/Luma Output
17	LV	GL0	OUT	Green/Luma Output (LSB)
18	X	PVSS	SUPPLY	Pad Ground
19	X	PVDD	SUPPLY	Pad Supply Voltage +5 V/+3.3 V
20	LV	RC7	OUT	Red/Chroma Output (MSB)
21	LV	RC6	OUT	Red/Chroma Output
22	LV	RC5	OUT	Red/Chroma Output
23	LV	RC4	OUT	Red/Chroma Output
24	LV	RC3	OUT	Red/Chroma Output
25	LV	RC2	OUT	Red/Chroma Output
26	LV	RC1	OUT	Red/Chroma Output
27	LV	RC0	OUT	Red/Chroma Output (LSB)
28	LV	AVO	OUT	Active Video Output
29	Supply +5 V	AVI	IN	Active Video Input
30	Supply +5 V	FSY	IN	Front Sync Input
31	X	SCL	IN/OUT	I ² C Clock Input/Output
32	X	SDA	IN/OUT	I ² C Data Input/Output
33	LV	PRI02	IN/OUT	Picture Bus Priority (MSB)
34	LV	PRI01	IN/OUT	Picture Bus Priority
35	LV	PRI00	IN/OUT	Picture Bus Priority (LSB)
36	DVSS	C0	IN	Chroma Input (LSB)
37	DVSS	C1	IN	Chroma Input
38	DVSS	C2	IN	Chroma Input
39	DVSS	C3	IN	Chroma Input
40	DVSS	C4	IN	Chroma Input
41	DVSS	C5	IN	Chroma Input
42	DVSS	C6	IN	Chroma Input
43	DVSS	C7	IN	Chroma Input (MSB)

Pin No. PLCC 68-pin	Connection (if not used)	Pin Name	Type	Short Description
44	DVSS	L0	IN	Luma Input (LSB)
45	DVSS	L1	IN	Luma Input
46	DVSS	L2	IN	Luma Input
47	DVSS	L3	IN	Luma Input
48	DVSS	L4	IN	Luma Input
49	DVSS	L5	IN	Luma Input
50	DVSS	L6	IN	Luma Input
51	DVSS	L7	IN	Luma Input (MSB)
52	X	DVSS	SUPPLY	Digital Ground
53	X	DVDD	SUPPLY	Digital Supply Voltage +5 V
54	X	CLK	IN	Main Clock Input
55	X	RESQ	IN	Reset Input
56	DVSS	TMODE	IN	Test Mode connect to ground
57	X	AVDD	SUPPLY	Analog Supply Voltage +5 V
58	X	AVSS	SUPPLY	Analog Ground
59	X	ADREF	Reference	External Capacitor
60	X	SUBSTRATE	–	Substrate connect to ground
61	AVSS	FB	IN	Fast Blank Input
62	AVSS	GNDFB	IN	Ground Fast Blank
63	AVSS	BU	IN	Blue/U Input
64	AVSS	GNDBU	IN	Ground Blue/U
65	AVSS	GY	IN	Green/Luma Input
66	AVSS	GNDGY	IN	Ground Green/Luma
67	AVSS	RV	IN	Red/V Input
68	AVSS	GNDRV	IN	Ground Red/V

3.3. Pin Descriptions

Pin 1 – STANDBY Input (Fig. 3–2)

Via this input pin, the standby mode of the CIP 3250A is enabled. A high level voltage switches all outputs to tristate mode, and power consumption is significantly reduced. When the IC is returned to active mode, a reset is generated internally. Connect to VSS if not used.

Pins 2 to 9 – B7 to B0 Blue Output (Fig.3–3)

In a stand alone application, where the CIP 3250A serves as an A/D-converter, these are the outputs for the digital Blue signal (pure binary) or the digital U signal (2's complement). Leave vacant if not used.

Pins 10 to 17 – GL7 to GL0 Green/Luma Output (Fig.3–3)

At these outputs, the digital luminance signal is received in pure binary coded format for DIGIT 2000 and DIGIT 3000 applications. In a stand alone application, where the CIP 3250A serves as an A/D-converter, these are the outputs for the digital Green signal (pure binary) or the digital luma signal (pure binary). Leave vacant if not used.

Pin 18 – PVSS Output Pin Ground

This is the common ground connection of all output stages and must be connected to ground.

Note: All ground pins of the chip (i.e. 18, 52, 58, 60, 62, 64, 66, and 68) must be connected together low resistive. The layout of the PCB must take into consideration the need for a low-noise ground.

Pin 19 – PVDD Output Pin Supply +5 V / +3.3 V

This pin supplies all output stages and must be connected to a positive supply voltage.

Note: The layout of the PCB must take into consideration the need for a low-noise supply. A bypass capacitor has to be connected between ground and PVDD (see section 4. Application Circuit).

Pins 20 to 27 – RC7 to RC0 Red/Chroma Output (Fig. 3–3)

These are the outputs for the digital chroma signal in the DIGIT 3000 system, where U and V are multiplexed bitwise. In a DIGIT 2000 system, RC3 to RC0 and RC7 to RC4 carry the halfbyte (nibble) multiplex format. In a stand alone application, where the CIP 3250A serves as an AD-converter, these are the outputs for the digital Red signal (pure binary) or the digital chroma V signal (2's complement). Leave vacant if not used.

Pin 28 – AVO Active Video Output (Fig. 3–4)

This output provides the Active Video signal, which carries information about the chroma multiplex in a DIGIT 3000 application and indicates valid video data at the Luma/Chroma outputs. This signal is programmable via I²C registers. Leave vacant if not used.

Pin 29 – AVI Active Video Input (Fig. 3–5)

In a DIGIT 2000 application, this input can be connected to ground. In a DIGIT 3000 application, this input expects the DIGIT 3000 AVI signal. In a stand alone application, this input expects the VSYNC vertical sync pulse. Connect to ground if not used.

Pin 30 – FSY Front Sync Input (Fig. 3–5)

In a DIGIT 2000 application, this input pin expects the DIGIT 2000 SKEW protocol. In a DIGIT 3000 application, this input expects the DIGIT 3000 FSY protocol. In a stand alone application, this input expects the HSYNC horizontal sync pulse. Connect to ground if not used.

Pins 31 to 32 – SDA and SCL of I²C-Bus (Fig. 3–6)

These pins connect to the I²C bus, which takes over the control of the CIP 3250A via the internal registers. The SDA pin is the data input/output, and the SCL pin is the clock input/output of I²C bus control interface. All registers are writeable (except address hex27) and readable.

Pins 33 to 35 – PRIO0 to PRIO2 Priority Bus (Fig. 3–7)

These pins connect to the Priority Bus of a DIGIT 3000 application. The Picture Bus Priority lines carry the digital priority selection signals. The priority interface allows digital switching of up to 8 sources to the backend processor. Switching for different sources is prioritized and can be on a per pixel basis. In all other applications, they must not be connected.

Pins 36 to 43 – C0 to C7 Chroma Input (Fig. 3–8)

These are the inputs for the digital chroma signal which can be received in binary offset or 2's complement coded format. In a DIGIT 2000 (4:1:1) system, C3 to C0 take the halfbyte (nibble) multiplex format. C7 to C4 have to be connected to ground. Within the DIGIT 3000 (4:2:2) system, U and V are multiplexed bitwise. Connect to ground if not used.

Pins 44 to 51 – L0 to L7 Luma Input (Fig. 3–8)

These are the inputs for the digital luma signal which must be in pure binary coded format. Connect to ground if not used.

Pin 52 – DVSS Digital Ground

This is the common ground connection of all digital stages and must be connected to ground.

Note: All ground pins of the chip (i.e. 18, 52, 58, 60, 62, 64, 66, and 68) must be connected together low resistive. The layout of the PCB must take into consideration the need for a low-noise ground.

Pin 53 – DVDD Digital Supply +5 V

This pin supplies all digital stages and must be connected to a positive supply voltage.

Note: The layout of the PCB must take into consideration the need for a low-noise supply. A bypass capacitor has to be connected between ground and DVDD (see section 4. Application Circuit).

Pin 54 – CLK Main Clock Input (Fig. 3–9)

This is the input for the clock signal. The frequency can vary in the range from 13.5 MHz to 20.25 MHz.

Pin 55 – RESQ Input (Fig. 3–10)

A low signal at this input pin generates a reset. The low-to-high transition of this signal should occur when the supply voltage is stable (power-on reset).

Pin 56 – TMODE Input (Fig. 3–2)

This pin is for test purposes only and must be connected to ground in normal operation.

Pin 57 – AVDD Analog Supply +5 V

This is the supply voltage pin for the A/D converters and must be connected to a positive supply voltage.

Note: The layout of the PCB must take into consideration the need for a low-noise supply. A bypass capacitor has to be connected between ground and AVDD.

Pin 58 – AVSS Analog Ground

This is the ground pin for the A/D converters and must be connected to ground.

Note: All ground pins of the chip (i.e. 18, 52, 58, 60, 62, 64, 66, and 68) must be connected together low resistive. The layout of the PCB must take into consideration the need for a low-noise ground.

Pin 59 – ADREF Connect External Capacitor (Fig. 3–11)

This pin should be connected to ground over a 10 μ F and a 100 nF capacitor in parallel.

Pin 60 – SUBSTRATE

This is connected to the platform which carries the “die” and must be connected to the ground.

Note: All ground pins of the chip (i.e. 18, 52, 58, 60, 62, 64, 66, and 68) must be connected together low resistive. The layout of the PCB must take into consideration the need for a low-noise ground.

Pin 61 – FB Analog Fast Blank Input (Fig. 3–12)

This input takes the DC-coupled analog Fast Blank signal. The amplitude is 1.0 V maximum at 75 Ohms. Connect to ground if not used.

Pin 62 – GNDFB Analog Ground

This is the ground pin for the AD converter of the Fast Blank signal and has to be connected to ground.

Note: All ground pins of the chip (i.e. 18, 52, 58, 60, 62, 64, 66, and 68) must be connected together low resistive. The layout of the PCB must take into consideration the need for a low-noise ground.

Pin 63 – BU Analog Blue/U Chroma Input (Fig. 3–13)

This input pin takes the AC-coupled analog component signal Blue or U Chroma. The amplitude is 1.0 V maximum at 75 Ohms and a coupling capacitor of 220 nF. Internally, the DC-offset of the input signal is adjusted via the programmable internal clamping circuit. Connect to ground if not used.

Pin 64 – GNDBU Analog Ground

This is the ground pin for the A/D converter of the Blue or U Chroma signal and must be connected to ground.

Note: All ground pins of the chip (i.e. 18, 52, 58, 60, 62, 64, 66, and 68) must be connected together low resistive. The layout of the PCB must take into consideration the need for a low-noise ground.

Pin 65 – GY Analog Green/Luma Input (Fig. 3–13)

This input pin takes the AC-coupled analog component signal Green or Luma. The amplitude is 1.0 V maximum at 75 Ohms and a coupling capacitor of 220 nF. Internally, the DC-offset of the input signal is adjusted via the programmable internal clamping circuit. Connect to ground if not used.

Pin 66 – GNDRY Analog Ground

This is the ground pin for the A/D converter of the Green or Luma signal and must be connected to ground.

Note: All ground pins of the chip (i.e. 18, 52, 58, 60, 62, 64, 66, and 68) must be connected together low resistive. The layout of the PCB must take into consideration the need for a low-noise ground.

Pin 67 – RV Analog Red/V Chroma Input (Fig. 3–13)

This input pin takes the AC-coupled analog component signal Red or V Chroma. The amplitude is 1.0 V maximum at 75 Ohms and a coupling capacitor of 220 nF. Internally, the DC-offset of the input signal is adjusted via the programmable internal clamping circuit. Connect to ground if not used.

Pin 68 – GNDRV Analog Ground

This is the ground pin for the A/D converter of the Red or V Chroma signal and must be connected to ground.

Note: All ground pins of the chip (i.e. 18, 52, 58, 60, 62, 64, 66, and 68) must be connected together low resistive. The layout of the PCB must take into consideration the need for a low-noise ground.

3.4. Pin Configuration

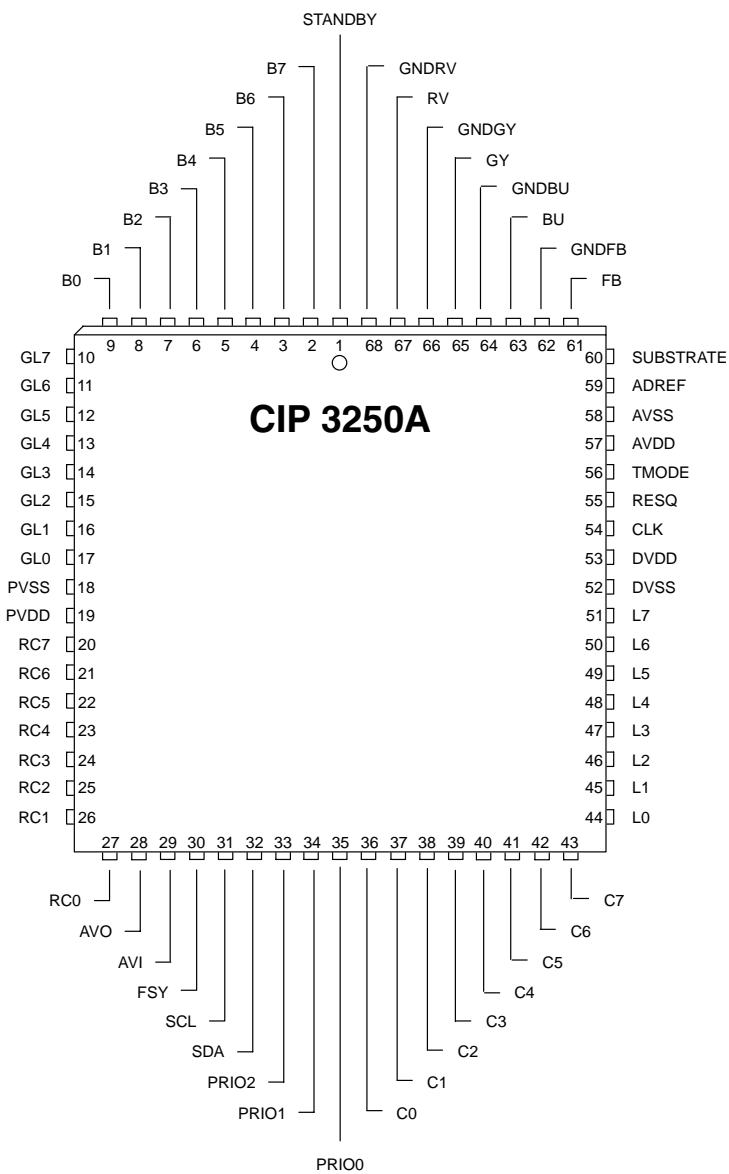

3.5. Pin Circuits

The following figures schematically show the circuitry at the various pins. The integrated protection structures are not shown.

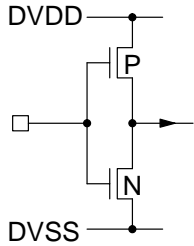

Fig. 3-2: Input pins 1 and 56

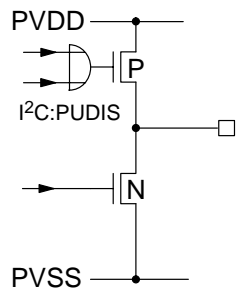

Fig. 3-3: Output pins 2 to 17 and 20 to 27

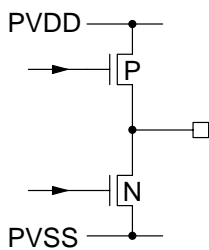

Fig. 3-4: Output pin 28

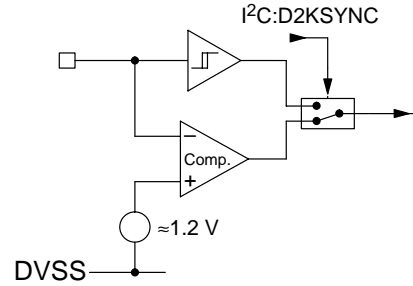

Fig. 3-5: Input pins 29 and 30

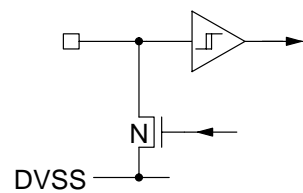

Fig. 3-6: Input pins 31 and 32

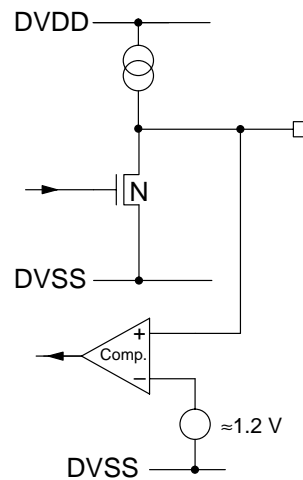

Fig. 3-7: Input/Output pins 33 to 35

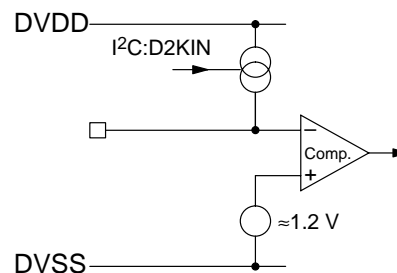

Fig. 3-8: Input pins 36 to 51

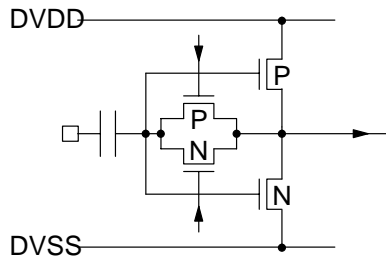

Fig. 3-9: Input pin 54

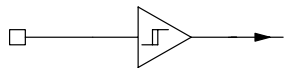

Fig. 3-10: Input pin 55

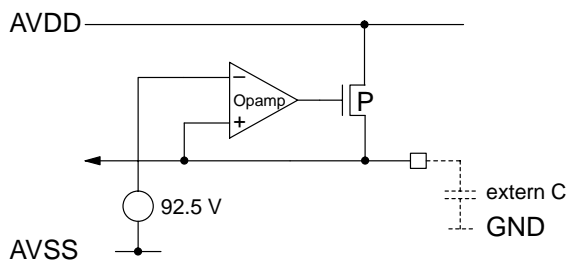

Fig. 3-11: Input pin 59

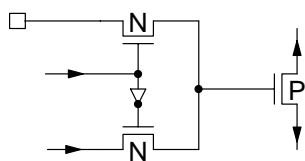

Fig. 3-12: Input pin 61

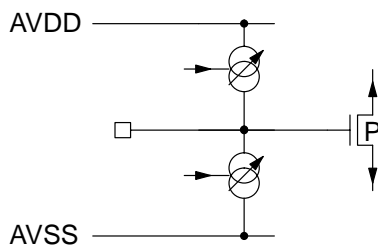

Fig. 3-13: Input pins 63, 65, and 67

3.6. Electrical Characteristics

3.6.1. Absolute Maximum Ratings

Symbol	Parameter	Min.	Max.	Unit
T_A	Ambient Temperature	0	65	°C
T_S	Storage Temperature	-40	125	°C
V_{SUP}	Supply Voltage, all Supply Inputs	-0.3	6	V
V_I	Input Voltage, all Inputs	-0.3	$V_{SUP}+0.3$	V
V_O	Output Voltage, at Outputs PRIO, SDA, and SCL	-0.3	$V_{SUP}+0.3$	V
V_O	Output Voltage, at Outputs GL, RC, B, and AVO	-0.3	$V_{EXT}+0.3$	V

Stresses beyond those listed in the “Absolute Maximum Ratings” may cause permanent damage to the device. This is a stress rating only. Functional operation of the device at these or any other conditions beyond those indicated in the “Recommended Operating Conditions/Characteristics” of this specification is not implied. Exposure to absolute maximum ratings conditions for extended periods may affect device reliability.

3.6.2. Recommended Operating Conditions

Symbol	Parameter	Pin Name	Min.	Typ.	Max.	Unit
T_A	Ambient Operating Temperature		0	–	65	°C
V_{SUP}	Supply Voltages Analog and Digital	DVDD, AVDD	4.75	5.0	5.25	V
V_{EXT}	Supply Voltages Output Circuits	PVDD	3.1	3.3	5.25	V
f_{MCLK}	Clock Frequency	CLK	13.50	–	20.25	MHz

3.6.3. Characteristics

at $T_A = 0$ to 65 °C, $V_{SUP} = 4.75$ to 5.25 V, $V_{EXT} = 3.1$ to 5.25 V, $f = 13.5$ to 20.25 MHz for min./max.-values
 at $T_A = 20$ °C, $V_{SUP} = 5$ V, $V_{EXT} = 3.3$ V, $f = 20.25$ MHz for typical values

Symbol	Parameter	Pin Name	Min.	Typ.	Max.	Unit	Test Conditions
I_{DIG}	Current Consumption Digital	DVDD		80		mA	$I^2C:<06>D2KIN = 1$ 70 pF load at all outputs
I_{ANA}	Current Consumption Analog	AVDD		70		mA	
I_{EXT}	Current Consumption Picture-Bus	PVDD		40		mA	70 pF load at all outputs
P_{TOT}	Total Power Dissipation			950		mW	$I^2C:<06>D2KIN = 1$ 70 pF load at all outputs
I_{SDTBY}	Standby Current Consumption	DVDD, AVDD, PVDD		tbd		mA	Standby pin = high
I_l	Leakage Current	L[7...0], C[7...0], RC[7...0], GL[7...0], B[7...0], PRIO[2:0], SDA, SCL, FSY, AVI, CLK, RESQ, TMODE, AVO, STANDBY, RV, GY, BU, FB			± 1	μA	Standby pin = high $U_{in} = 0$ V/5 V
C_1	Input Capacitance			4		pF	at DC = 0 V, AC = 100 mV $f = 10$ MHz

3.6.3.1. Characteristics Standby Input

Symbol	Parameter	Pin Name	Min.	Typ.	Max.	Unit	Test Conditions
V_{IL}	Input Low Voltage	STANDBY	–	–	0.8	V	
V_{IH}	Input High Voltage		2.0	–	–	V	

3.6.3.2. Characteristics Test Input

Symbol	Parameter	Pin Name	Min.	Typ.	Max.	Unit	Test Conditions
V_{IL}	Input Low Voltage	TMODE	–	–	0.8	V	
V_{IH}	Input High Voltage		2.0	–	–	V	

3.6.3.3. Characteristics Reset Input

Symbol	Parameter	Pin Name	Min.	Typ.	Max.	Unit	Test Conditions
V_{IL}	Input Low Voltage	RESQ	–	–	1.3	V	
V_{IH}	Input High Voltage		3.3	–	–	V	

3.6.3.4. Characteristics Main Clock Input

Symbol	Parameter	Pin Name	Min.	Typ.	Max.	Unit	Test Conditions
$V_{\Phi MIDC}$	Φ M Main Clock Input DC Voltage	CLK	1.5	–	3.5	V	
$V_{\Phi MIAC}$	Φ M Main Clock Input AC Voltage (p-p)		0.8	–	2.5	V	
$\frac{t_{\Phi MIH}}{t_{\Phi MIL}}$	Φ M Clock Input High to Low Ratio		$\frac{2}{3}$	$\frac{1}{1}$	$\frac{3}{2}$		
$t_{\Phi MIHL}$	Φ M Clock Input High to Low Transition Time		–	–	$\frac{0.15}{f_{\Phi M}}$		
$t_{\Phi MILH}$	Φ M Clock Input Low to High Transition Time		–	–	$\frac{0.15}{f_{\Phi M}}$		

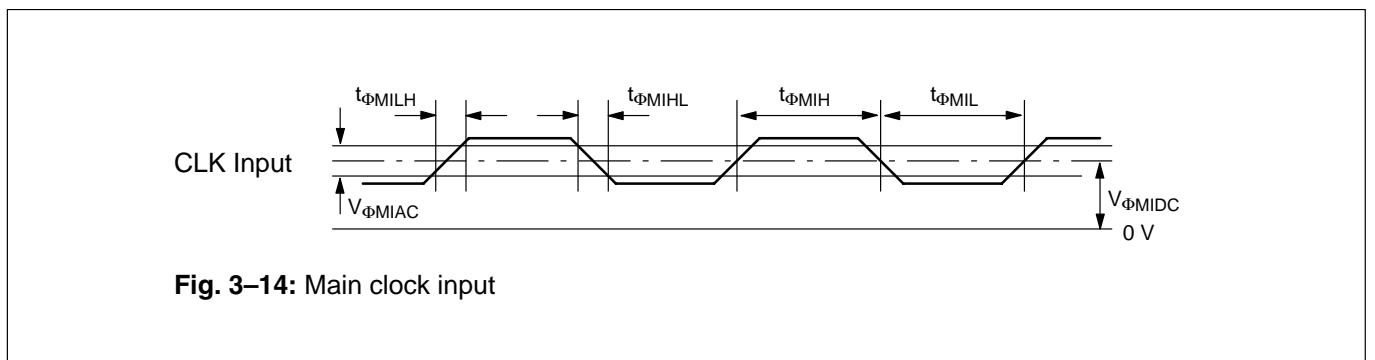

3.6.3.5. Characteristics Active Video Output

Symbol	Parameter	Pin Name	Min.	Typ.	Max.	Unit	Test Conditions
V_{OL}	Output Low Voltage	AVO	–	–	0.4	V	Load as described at $I^2C:<14>LOAD$
V_{OH}	Output High Voltage		2.4	–	–	V	Load as described at $I^2C:<14>LOAD$
t_{OD}	Output Delay Time after active Clock Transition		–	–	35	ns	Load as described at $I^2C:<14>LOAD$
t_{OH}	Output Hold Time after active Clock Transition		6	–	–	ns	

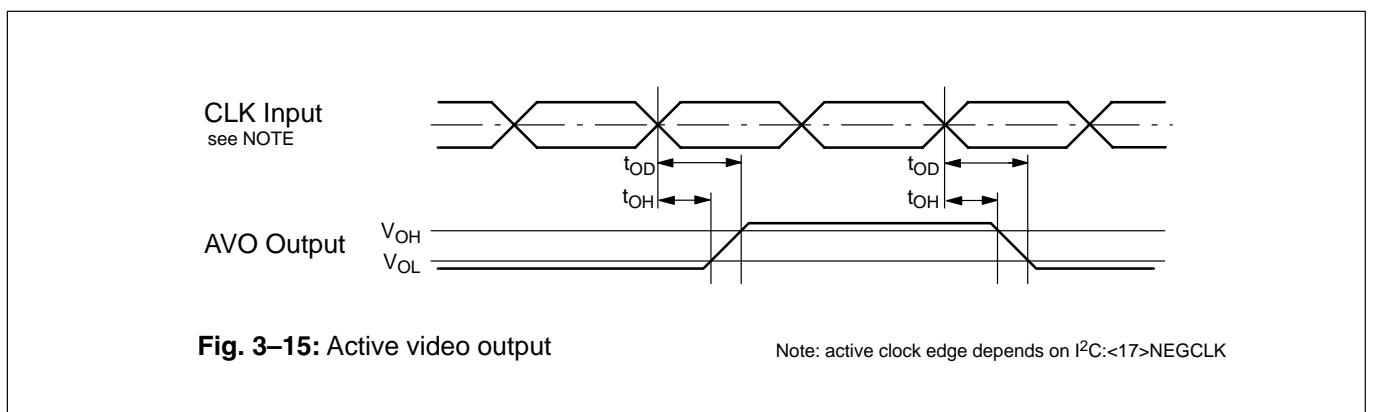

3.6.3.6. Characteristics Active Video Input

Symbol	Parameter	Pin Name	Min.	Typ.	Max.	Unit	Test Conditions
V_{IL}	Input Low Voltage	AVI	–	–	1.3	V	$I^2C:<17>D2KSYNC = 1$ $I^2C:<17>D2KSYNC = 0$
V_{IH}	Input High Voltage		3.3	–	–	V	$I^2C:<17>D2KSYNC = 1$ $I^2C:<17>D2KSYNC = 0$
t_{IS}	Input Setup Time before active Clock Transition		7	–	–	ns	
t_{IH}	Input Hold Time after active Clock Transition		5	–	–	ns	

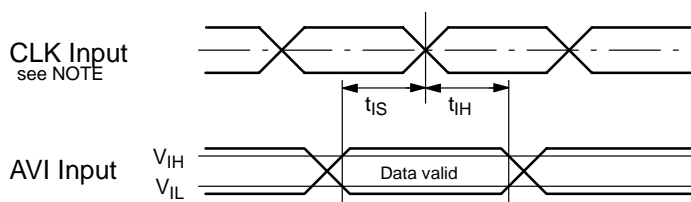

Fig. 3–16: Active video input

Note: active clock edge depends on $I^2C:<17>NEGCLK$

3.6.3.7. Characteristics Fsync Input

Symbol	Parameter	Pin Name	Min.	Typ.	Max.	Unit	Test Conditions
V_{IL}	Input Low Voltage	FSY	–	–	1.3	V	$I^2C: D2KSYNC = 1$ $I^2C: D2KSYNC = 0$
V_{IH}	Input High Voltage		3.3	–	–	V	$I^2C: D2KSYNC = 1$ $I^2C: D2KSYNC = 0$
t_{IS}	Input Setup Time before active Clock Transition		7	–	–	ns	
t_{IH}	Input Hold Time after active Clock Transition		5	–	–	ns	

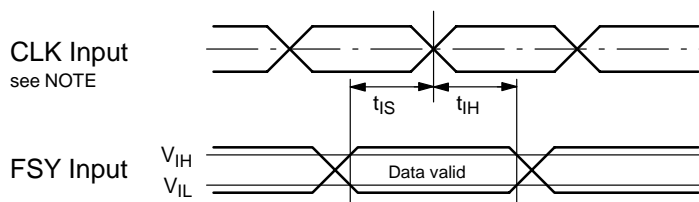

Fig. 3–17: Fsync input

Note: active clock edge depends on $I^2C:<17>NEGCLK$

3.6.3.8. Characteristics I²C Bus Interface Input/Output

Symbol	Parameter	Pin Name	Min.	Typ.	Max.	Unit	Test Conditions
V _{IL}	Input Low Voltage	SDA, SCL	–	–	0.3*V _{DD}	V	
V _{IH}	Input High Voltage		0.6*V _{DD}	–	–	V	
V _{OL}	Output Low Voltage		–	–	0.4 0.6	V V	I _I = 3 mA I _I = 6 mA
t _F	Signal Fall Time		–	–	300	ns	C _L = 400 pF
f _{SCL}	Clock Frequency	SCL	0	–	400	kHz	
t _{I2C3}	I ² C-Clock Low Pulse Time		500	–	–	ns	
t _{I2C4}	I ² C-Clock High Pulse Time		500	–	–	ns	
t _{I2C1}	I ² C Start Condition Setup Time	SCL, SDA	120	–	–	ns	
t _{I2C2}	I ² C Stop Condition Setup Time		120	–	–	ns	
t _{I2C5}	I ² C-Data Setup Time Before Rising Edge of Clock SCL		55	–	–	ns	
t _{I2C6}	I ² C-Data Hold Time after Falling Edge of Clock SCL		55	–	–	ns	
t _{I2C7}	I ² C-Slew Times at I ² C-Clock = 1 MHz		50	–	–	V/μs	

3.6.3.9. Characteristics Luma/Chroma Input

Symbol	Parameter	Pin Name	Min.	Typ.	Max.	Unit	Test Conditions
V _{IL}	Input Low Voltage	L[7..0], C[7..0]	–	–	0.8	V	
V _{IH}	Input High Voltage		1.5	–	–	V	
I _{PUP}	Pullup Current		1.5 –	2.1 –	3.0 ±1	mA μA	@ 1 Volt / I ² C:<06>D2KIN = 1 @ 1 Volt / I ² C:<06>D2KIN = 0
V _{PUP}	Pullup Voltage		1.8 –	– –	3.2 –	V V	I ² C:<06>D2KIN = 1 I ² C:<06>D2KIN = 0
t _{IS}	Input Setup Time before active Clock Transition		7	–	–	ns	
t _{IH}	Input Hold Time after active Clock Transition		5	–	–	ns	

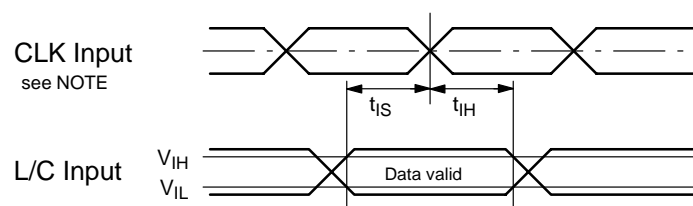

Fig. 3–18: Luma/chroma input

Note: active clock edge depends on I²C:<17>NEGCLK

3.6.3.10. Characteristics Priority Input/Output

Symbol	Parameter	Pin Name	Min.	Typ.	Max.	Unit	Test Conditions
V_{IL}	Input Low Voltage	PRIO[2...0]	–	–	0.8	V	
V_{IH}	Input High Voltage		1.5	–	–	V	
V_{OL}	Output Low Voltage		–	–	0.6	V	Load as described at I ² C:<14>LOAD
I_{PUP}	Pullup Current		1.2	–	2.0	mA	@ 1 Volt
V_{PUP}	Pullup Voltage		1.8	2.0	2.5	V	
t_{IS}	Input Setup Time before active Clock Transition		7	–	–	ns	
t_{IH}	Input Hold Time after active Clock Transition		5	–	–	ns	
t_{OD}	Output Delay Time after active Clock Transition		–	–	35	ns	Load as described at I ² C:<14>LOAD
t_{OH}	Output Hold Time after active Clock Transition		6	–	–	ns	
t_{OHL}	Output Low Hold Time after active Clock Transition		6	–	15	ns	

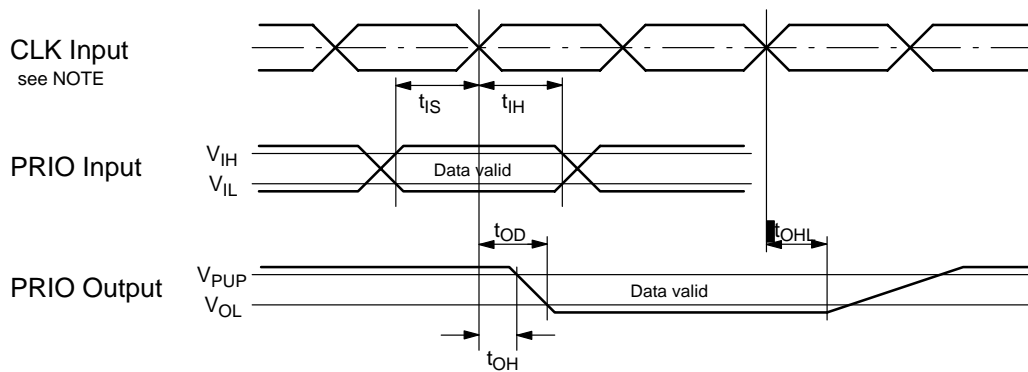
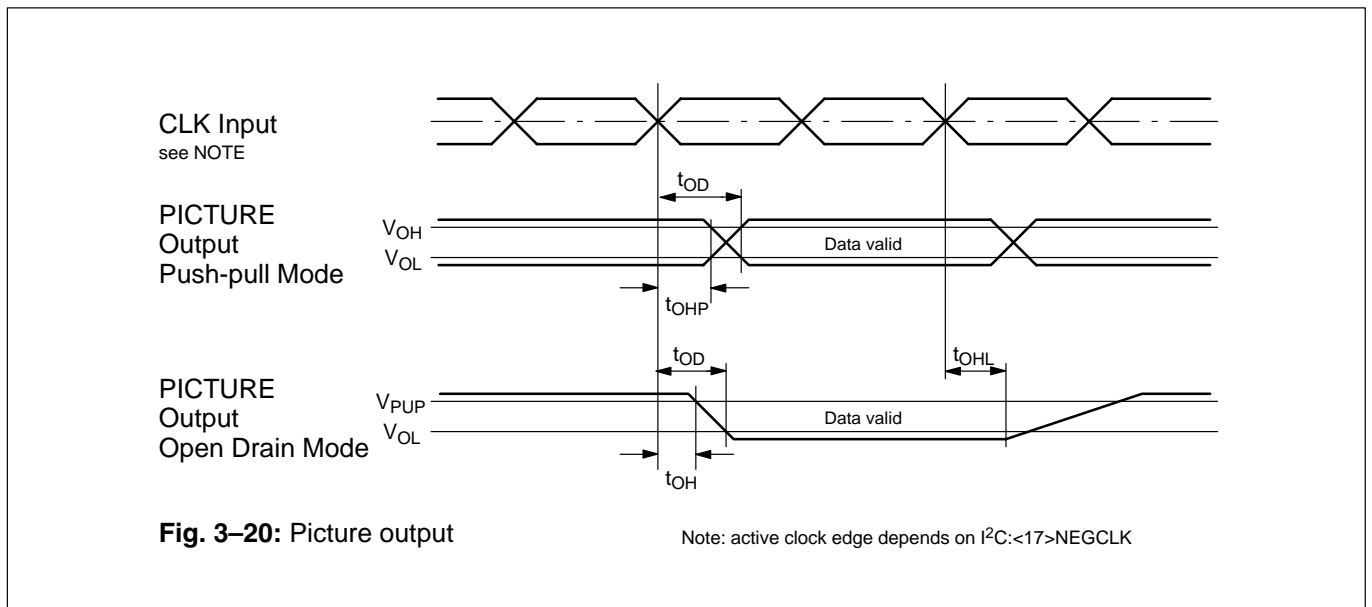

Fig. 3–19: Priority input/output

Note: active clock edge depends on I²C:<17>NEGCLK

3.6.3.11. Characteristics Picture Output

Symbol	Parameter	Pin Name	Min.	Typ.	Max.	Unit	Test Conditions
V_{OL}	Output Low Voltage	RC[7..0], GL[7..0], B[7..0]	–	–	0.4	V	Load as described at $I^2C:<14>LOAD$
V_{OH}	Output High Voltage (only in Push-pull Mode)		2.4	–	–	V	Load as described at $I^2C:<14>LOAD$ $I^2C:<14>PUDIS = 0$
t_{OD}	Output Delay Time after active Clock Transition		–	–	35	ns	Load as described at $I^2C:<14>LOAD$
t_{OH}	Output Hold Time after active Clock Transition		6	–	–	ns	
t_{OHL}	Output Low Hold Time after active Clock Transition		6	–	15	ns	



3.6.3.12. Characteristics Analog R, G, B Inputs

Symbol	Parameter	Pin Name	Min.	Typ.	Max.	Unit	Test Conditions	
V _{VRT}	Reference Voltage Top	ADREF	2.4	2.6	2.8	V	10 μF/10 nF, 1GΩ Probe I ² C: <14>LOAD = 3	
RGB – Path								
R _{VIN}	Input Resistance	RV GY BU	5			MΩ	Code Clamp–DAC=0	
C _{VIN}	Input Capacitance			4.5			pF	
V _{VIN}	Full Scale Input Voltage		0.85	1.0	1.1	V _{PP}	Full Scale 0 ... 255	
V _{VINCL}	Input Clamping Level, UV for Binary Code 128			1.5		V	Binary Level = 128 LSB	
V _{VINCL}	Input Clamping Level, RGB, Y for Binary Code 16			1.06		V	Binary Level = 16 LSB	
	Gain Match					tbd	%	Full Scale @ 1 MHz
Q _{CL}	Clamping DAC Resolution			–32		31	steps	6 Bit – I–DAC, bipolar V _{VIN} =1.5 V
I _{CL–LSB}	Input Clamping Current per step			0.59	0.85	1.11	μA	
IN _{I–CL}	Clamping DAC Integral Non-Linearity					±0.5	LSB	
C _{ICL}	Clamping–Capacitor			–	220	–	nF	Coupling–Cap. @ Inputs
Dynamic Characteristics for RGB–Path at V _{EXT} = 3.3 V, 70 pF load at all outputs, I ² C: <14>LOAD = 0								
BW	Bandwidth	RV GY BU	8			MHz	–2 dBr input signal pegel	
XTALK	Crosstalk, any Two Video Inputs			–42		–tbd	dB	1 MHz, –2 dBr signal pegel
THD	Total Harmonic Distortion			–42		–tbd	dB	1 MHz, 5 harmonics, –2 dBr signal pegel
SINAD	Signal to Noise and Distortion Ratio			tbd	tbd		dB	1 MHz, all outputs, –2 dBr signal pegel
INL	Integral Non-Linearity,					±4.0	LSB	Code Density, DC–ramp
DNL	Differential Non-Linearity					±1.0	LSB	

3.6.3.13. Characteristics Analog FBL Input

Symbol	Parameter	Pin Name	Min.	Typ.	Max.	Unit	Test Conditions	
R _{FBIN}	Input Resistance	FB	5	–	–	MΩ		
V _{FBIN}	Full Scale Input Voltage		0.85	1.0	1.1	V _{PP}	Full Scale 0 ... 63	
	Threshold for FBL–Monitor		0.5	0.65	0.8	V _{PP}		
Dynamic Characteristics for FBL Input at V _{EXT} = 3.3 V, 70 pF load at all outputs, I ² C: <14>LOAD = 0								
BW	Bandwidth	FB	8			MHz	–2 dBr input signal pegel	
THD	Total Harmonic Distortion			–38		–tbd	dB	1 MHz, 5 harmonics, –2 dBr signal pegel
SINAD	Signal to Noise and Distortion Ratio			tbd	–36		dB	1 MHz, all outputs, –2 dBr signal pegel

4. Application Circuit

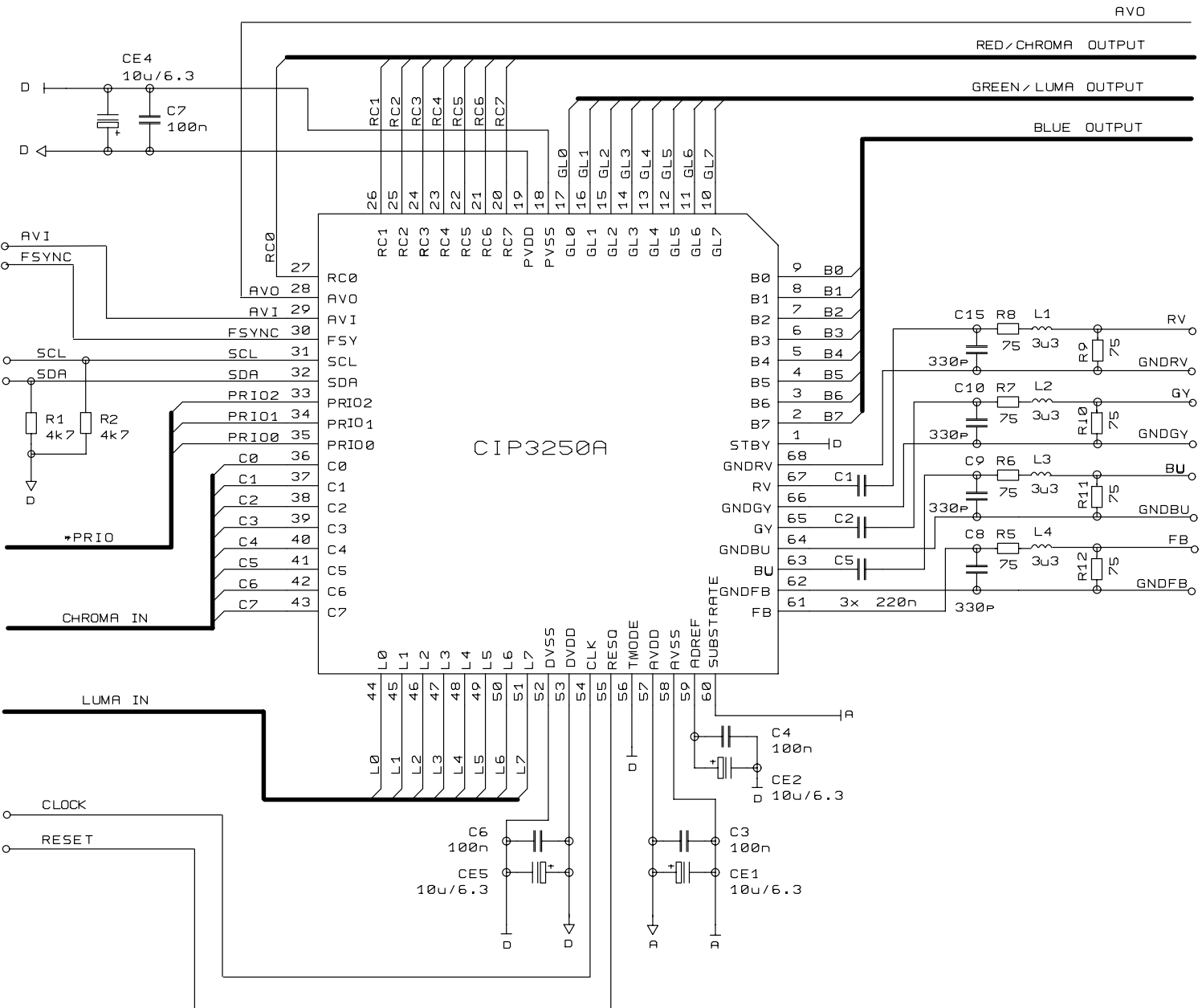

5. Data Sheet History

1. Advance Information: "CIP 3250 Component Interface Processor", May 2, 1995, 6251-403-1AI.
First release of the advance information.

2. Advance Information: "CIP 3250A Component Interface Processor", Feb. 16, 1996, 6251-403-2AI.
Second release of the advance information.

Major changes:

- Modifications and new features from CIP 3250 to CIP 3250A
- Fig. 3–1: PLCC68 package dimensions changed
- section 3.2.: Pin Connections and Short Descriptions new
- Correction of errors

3. Advance Information: "CIP 3250A Component Interface Processor", Oct. 9, 1996, 6251-403-3AI.
Third release of the advance information.

Major changes:

- section 2.7.: Modified description of Soft Mixer and Fast Blank Monitor, Fig. 2–4: Fast Blank Processing changed, Fig. 2–5: Fast Blank Monitor, Fig. 2–6: DIGIT 2000 skew data and Fig. 2–7: DIGIT 3000 front sync format new
- section 2.9.: Table 2–2: Digital input selection new
- section 2.12.: Table 2–3: Digital output selection new
- section 2.16.: Table 2–10 modified and description of <04>CLSEL changed; Fig. 2–14: DL2-setup and Fig 2–15: DL2-reset during line 7 changed
- section 3.6.3.12. and 3.6.3.13.: new characteristics
- section 4.: Application Circuit new

Micronas GmbH
Hans-Bunte-Strasse 19
D-79108 Freiburg (Germany)
P.O. Box 840
D-79008 Freiburg (Germany)
Tel. +49-761-517-0
Fax +49-761-517-2174
E-mail: docservice@micronas.com
Internet: www.micronas.com

Printed in Germany
Order No. 6251-403-3AI

All information and data contained in this data sheet are without any commitment, are not to be considered as an offer for conclusion of a contract, nor shall they be construed as to create any liability. Any new issue of this data sheet invalidates previous issues. Product availability and delivery are exclusively subject to our respective order confirmation form; the same applies to orders based on development samples delivered. By this publication, Micronas GmbH does not assume responsibility for patent infringements or other rights of third parties which may result from its use.

Further, Micronas GmbH reserves the right to revise this publication and to make changes to its content, at any time, without obligation to notify any person or entity of such revisions or changes.

No part of this publication may be reproduced, photocopied, stored on a retrieval system, or transmitted without the express written consent of Micronas GmbH.