

PRELIMINARY DATA SHEET

VDP 31xxB Video Processor Family

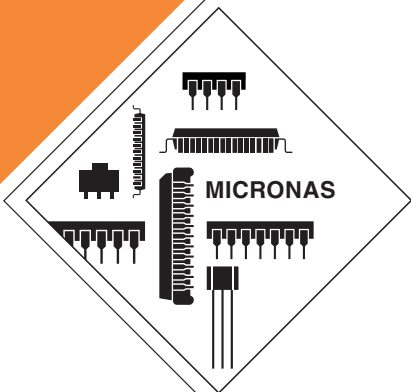

Edition Sept. 25, 1998
6251-437-2PD

 MICRONAS

Contents

| Page | Section | Title |
|-------------|----------------|---------------------------------------|
| 5 | 1. | Introduction |
| 6 | 1.1. | VDP Applications |
| 7 | 2. | Functional Description |
| 7 | 2.1. | Analog Front-End |
| 7 | 2.1.1. | Input Selector |
| 7 | 2.1.2. | Clamping |
| 7 | 2.1.3. | Automatic Gain Control |
| 7 | 2.1.4. | Analog-to-Digital Converters |
| 7 | 2.1.5. | ADC Range |
| 7 | 2.1.6. | Digitally Controlled Clock Oscillator |
| 7 | 2.1.7. | Analog Video Output |
| 9 | 2.2. | Adaptive Comb Filter |
| 10 | 2.3. | Color Decoder |
| 10 | 2.3.1. | IF-Compensation |
| 11 | 2.3.2. | Demodulator |
| 11 | 2.3.3. | Chrominance Filter |
| 11 | 2.3.4. | Frequency Demodulator |
| 11 | 2.3.5. | Burst Detection |
| 11 | 2.3.6. | Color Killer Operation |
| 11 | 2.3.7. | PAL Compensation/1-H Comb Filter |
| 12 | 2.3.8. | Luminance Notch Filter |
| 12 | 2.3.9. | Skew Filtering |
| 13 | 2.4. | Horizontal Scaler |
| 13 | 2.5. | Black-Line Detector |
| 13 | 2.6. | Test Pattern Generator |
| 14 | 2.7. | Video Sync Processing |
| 15 | 2.8. | Display Part |
| 15 | 2.8.1. | Luma Contrast Adjustment |
| 15 | 2.8.2. | Black Level Expander |
| 16 | 2.8.3. | Dynamic Peaking |
| 17 | 2.8.4. | Digital Brightness Adjustment |
| 17 | 2.8.5. | Soft Limiter |
| 17 | 2.8.6. | Chroma Input |
| 17 | 2.8.7. | Chroma Interpolation |
| 18 | 2.8.8. | Chroma Transient Improvement |
| 18 | 2.8.9. | Inverse Matrix |
| 18 | 2.8.10. | RGB Processing |
| 18 | 2.8.11. | OSD Color Lookup Table |
| 19 | 2.8.12. | Picture Frame Generator |
| 19 | 2.8.13. | Priority Codec |
| 19 | 2.8.14. | Scan Velocity Modulation |
| 19 | 2.8.15. | Display Phase Shifter |

Contents, continued

| Page | Section | Title |
|-------------|----------------|---|
| 21 | 2.9. | Analog Back End |
| 21 | 2.9.1. | CRT Measurement and Control |
| 22 | 2.9.2. | SCART Output Signal |
| 23 | 2.9.3. | Average Beam Current Limiter |
| 23 | 2.9.4. | Analog RGB Insertion |
| 24 | 2.9.5. | Fast Blank Monitor |
| 24 | 2.9.6. | Half Contrast Control |
| 24 | 2.10. | IO Port Expander |
| 26 | 2.11. | Synchronization and Deflection |
| 26 | 2.11.1. | Deflection Processing |
| 26 | 2.11.2. | Horizontal Phase Adjustment |
| 28 | 2.11.3. | Vertical and East/West Deflection |
| 28 | 2.11.4. | Protection Circuitry |
| 29 | 2.12. | Reset Function |
| 29 | 2.13. | Standby and Power-On |
| 30 | 3. | Serial Interface |
| 30 | 3.1. | I ² C-Bus Interface |
| 30 | 3.2. | Control and Status Registers |
| 43 | 3.2.1. | Scaler Adjustment |
| 46 | 3.2.2. | Calculation of Vertical and East-West Deflection Coefficients |
| 47 | 4. | Specifications |
| 47 | 4.1. | Outline Dimensions |
| 47 | 4.2. | Pin Connections and Short Descriptions |
| 49 | 4.3. | Pin Descriptions |
| 51 | 4.4. | Pin Configuration |
| 52 | 4.5. | Pin Circuits |
| 54 | 4.6. | Electrical Characteristics |
| 54 | 4.6.1. | Absolute Maximum Ratings |
| 54 | 4.6.2. | Recommended Operating Conditions |
| 54 | 4.6.3. | Recommended Crystal Characteristics |
| 55 | 4.6.4. | Characteristics |
| 56 | 4.6.4.1. | 5 MHz Clock Output |
| 56 | 4.6.4.2. | 20 MHz Clock Input/Output, External Clock Input (XTAL1) |
| 56 | 4.6.4.3. | Reset Input, Test Input |
| 57 | 4.6.4.4. | I ² C-Bus Interface |
| 57 | 4.6.4.5. | IO Port Expander |
| 57 | 4.6.4.6. | Analog Video Inputs |
| 58 | 4.6.4.7. | Analog Front-End and ADCs |
| 59 | 4.6.4.8. | Picture Bus Input |
| 60 | 4.6.4.9. | INTLC, Front Sync Output |
| 60 | 4.6.4.10. | Main Sync Output |
| 60 | 4.6.4.11. | Combined Sync Output |

Contents, continued

| Page | Section | Title |
|-------------|----------------|-------------------------------------|
| 61 | 4.6.4.12. | Horizontal Flyback Input |
| 61 | 4.6.4.13. | Horizontal Drive Output |
| 61 | 4.6.4.14. | Vertical Protection Input |
| 61 | 4.6.4.15. | Vertical Safety Input |
| 62 | 4.6.4.16. | Vertical and East/West Drive Output |
| 62 | 4.6.4.17. | Sense A/D Converter Input |
| 62 | 4.6.4.18. | Analog RGB and FB Inputs |
| 63 | 4.6.4.19. | Half Contrast Switch Input |
| 64 | 4.6.4.20. | Analog RGB Outputs, D/A Converters |
| 66 | 4.6.4.21. | DAC Reference, Beam Current Safety |
| 66 | 4.6.4.22. | Scan Velocity Modulation Output |
| 67 | 5. | Application Circuit |
| 72 | 6. | Data Sheet History |

Video, Display, and Deflection Processor

VPC 3200A Video Processor and DDP 3300A Display and Deflection Processor.

Release Notes: This data sheet describes functions and characteristics of the VDP 31xxB–C2. Revision bars indicate significant changes to the previous edition.

Each member of the family contains the entire video, display, and deflection processing for 4:3 and 16:9 50/60 TV sets. Its performance and flexibility allow the user to standardize his product development. Hardware and software applications can profit from the modularity, as well as manufacturing, systems support, or maintenance. An overview of the VDP 31xxB video processor family is shown in Fig. 1–1.

1. Introduction

The VDP 31xxB is a Video IC family of high-quality single-chip video processors. Modular design and a submicron technology allow the economic integration of features in all classes of TV sets. The VDP 31xxB family is based on functional blocks contained in the two chips:

| VDP 31xxB Family | 1H Combfilter | 2H adapt. Comb | Horizontal Scaler | Color Trans. Impr. | Scan Vel. Mod. | Prog. RGB Matrix | RGB Insertion | Tube Control |
|------------------|---------------|----------------|-------------------|--------------------|----------------|------------------|---------------|--------------|
| VDP 3104B | ✓ | | | | | ✓ | ✓ | ✓ |
| VDP 3108B | ✓ | | | ✓ | ✓ | ✓ | ✓ | ✓ |
| VDP 3112B | ✓ | ✓ | | ✓ | ✓ | ✓ | ✓ | ✓ |
| VDP 3116B | ✓ | | ✓ | ✓ | ✓ | ✓ | ✓ | ✓ |
| VDP 3120B | ✓ | ✓ | ✓ | ✓ | ✓ | ✓ | ✓ | ✓ |

Fig. 1–1: VDP 31xxB family overview

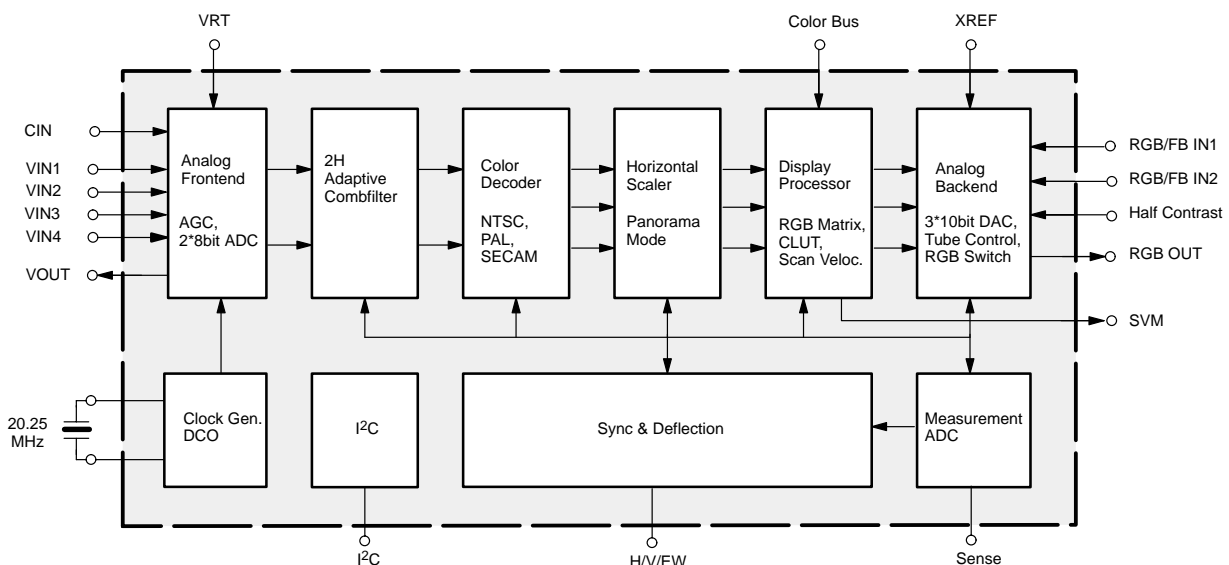

Fig. 1–2: Block diagram of the VDP 3120B

1.1. VDP Applications

As a member of the VDP 31xxB family, the VDP 3120B offers all video features necessary to design a state-of-the-art TV set:

Video Decoding

- 4 composite inputs, 1 S-VHS input
- composite video & sync output
- integrated high-quality A/D converters
- adaptive 2H comb filter Y/C separator
- 1H NTSC comb filter
- multistandard color decoder (1 crystal)
- multistandard sync decoder
- black line detector

Video Processing

- horizontal scaling (0.25 to 4)
- panorama vision
- black level expander
- dynamic peaking
- soft limiter (gamma correction)
- color transient improvement

RGB Processing

- programmable RGB matrix
- digital color bus interface
- additional analog RGB / fast blank input
- half-contrast switch
- picture frame generator

Deflection

- scan velocity modulation output
- high-performance H/V deflection
- separate ADC for tube measurements
- EHT compensation

Miscellaneous

- one 20.25 MHz crystal, few external components
- embedded RISC controller (80 MIPS)
- I²C-Bus Interface
- single 5 V power supply
- submicron CMOS technology
- 64-pin PSDIP package

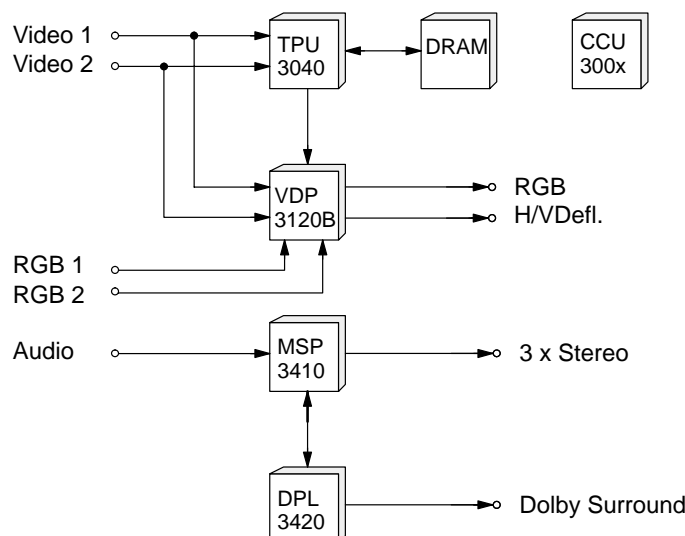

Fig. 1–3: Full-feature TV set with VDP 3120B

2. Functional Description

2.1. Analog Front-End

This block provides the analog interfaces to all video inputs and mainly carries out analog-to-digital conversion for the following digital video processing. A block diagram is given in Fig. 2–1.

Most of the functional blocks in the front-end are digitally controlled (clamping, AGC, and clock-DCO). The control loops are closed by the Fast Processor ('FP') embedded in the decoder.

2.1.1. Input Selector

Up to five analog inputs can be connected. Four inputs are for input of composite video or S-VHS luma signal. These inputs are clamped to the sync back porch and are amplified by a variable gain amplifier. One input is for connection of S-VHS carrier-chrominance signal. This input is internally biased and has a fixed gain amplifier.

2.1.2. Clamping

The composite video input signals are AC coupled to the IC. The clamping voltage is stored on the coupling capacitors and is generated by digitally controlled current sources. The clamping level is the back porch of the video signal. S-VHS chroma is also AC coupled. The input pin is internally biased to the center of the ADC input range.

2.1.3. Automatic Gain Control

A digitally working automatic gain control adjusts the magnitude of the selected baseband by $+6/-4.5$ dB in 64 logarithmic steps to the optimal range of the ADC. The gain of the video input stage including the ADC is 213 steps/V with the AGC set to 0 dB.

2.1.4. Analog-to-Digital Converters

Two ADCs are provided to digitize the input signals. Each converter runs with 20.25 MHz and has 8 bit resolution. An integrated bandgap circuit generates the required reference voltages for the converters.

2.1.5. ADC Range

The ADC input range for the various input signals and the digital representation is given in Table 2–1 and Fig. 2–2. The corresponding output signal levels of the VDP 31xxB are also shown.

2.1.6. Digitally Controlled Clock Oscillator

The clock generation is also a part of the analog front end. The crystal oscillator is controlled digitally by the control processor; the clock frequency can be adjusted within ± 150 ppm.

2.1.7. Analog Video Output

The input signal of the Luma ADC is available at the analog video output pin. The signal at this pin must be buffered by a source follower. The output voltage is 2 V, thus the signal can be used to drive a 75 Ω line. The magnitude is adjusted with an AGC in 8 steps together with the main AGC.

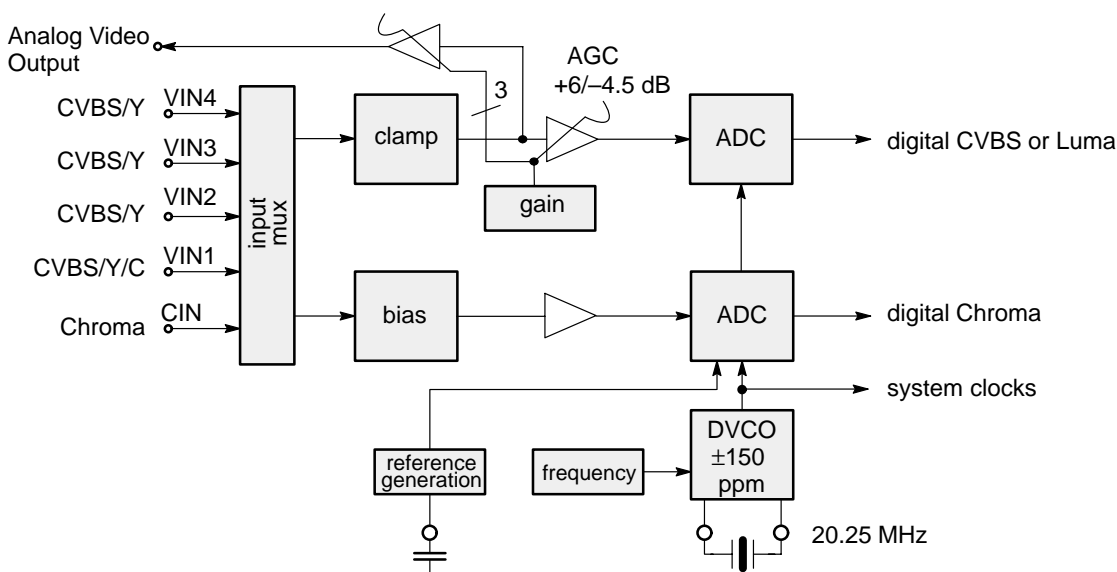

Fig. 2–1: Analog front-end

Table 2–1: ADC input range for PAL input signal and corresponding signal ranges

| Signal | | Input Level [mV _{pp}] | | | ADC Range | Y _C R _C B _C Internal Range |
|--------|--------------|---------------------------------|------|---------|-----------|---|
| | | –6 dB | 0 dB | +4.5 dB | | |
| | | | | | [steps] | [steps] |
| CVBS | 100% CVBS | 667 | 1333 | 2238 | 252 | – |
| | 75% CVBS | 500 | 1000 | 1679 | 213 | – |
| | video (luma) | 350 | 700 | 1175 | 149 | 224 |
| | sync height | 150 | 300 | 504 | 64 | – |
| | clamp level | | | | 68 | 16 |
| Chroma | burst | | 300 | | 64 | – |
| | 100% Chroma | | 890 | | 190 | 128±112 |
| | 75% Chroma | | 670 | | 143 | 128±84 |
| | bias level | | | | 128 | 128 |

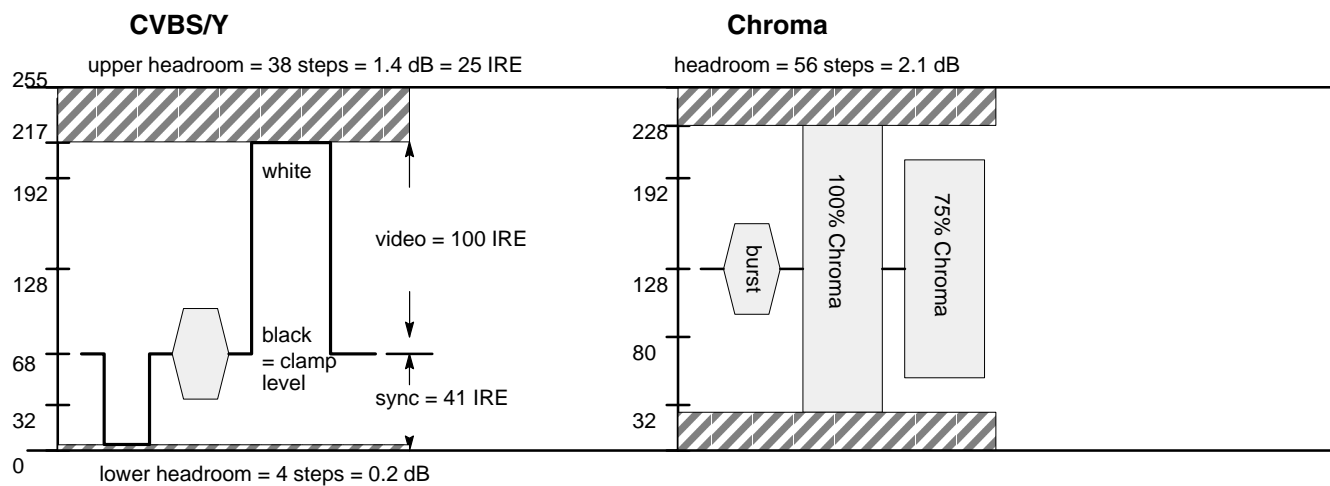

Fig. 2–2: ADC ranges for CVBS/Luma and Chroma, PAL input signal

2.2. Adaptive Comb Filter

The adaptive comb filter is used for high-quality luminance/chrominance separation for PAL or NTSC signals. The comb filter improves the luminance resolution (bandwidth) and reduces interferences like cross-luminance and cross-color artifacts. The adaptive algorithm can eliminate most of the mentioned errors without introducing new artifacts or noise.

A block diagram of the comb filter is shown in Fig. 2–3. The filter uses two line delays to process the information of three adjacent video lines. To have a fixed phase relationship of the color subcarrier in the three channels, the system clock (20.25 MHz) is fractionally locked to the color subcarrier. This allows the processing of all color standards and substandards using a single crystal frequency.

The CVBS signal in the three channels is filtered at the subcarrier frequency by a set of bandpass/notch filters. The output of the three channels is used by the adaption logic to select the weighting that is used to reconstruct the luminance/chrominance signal from the 4 bandpass/notch filter signals. By using soft mixing of the 4 signals switching artifacts of the adaption algorithm are completely suppressed.

The comb filter uses the middle line as reference, therefore, the comb filter delay is one line. If the comb filter is switched off, the delay lines are used to pass the luma/chroma signals from the A/D converters to the luma/chroma outputs. Thus, the comb filter delay is always one line.

Various parameters of the comb filter are adjustable, hence giving to the user the ability to adjust his own desired picture quality.

Two parameters (KY, KC) set the global gain of luma and chroma comb separately; these values directly weigh the adaption algorithm output. In this way, it is possible to obtain a luma/chroma separation ranging from standard notch/bandpass to full comb decoding.

The parameter KB allows to choose between the two proposed comb booster modes. This so-called feature widely improves vertical high to low frequency transitions areas, the typical example being a multiburst to dc change. For KB=0, this improvement is kept moderate, whereas, in case of KB=1, it is maximum, but the risk to increase the “hanging dots” amount for some given color transitions is higher.

Using the default setting, the comb filter has separate luma and chroma decision algorithms; it is however possible to switch the chroma comb factor to the current luma adaption output by setting CC to 1.

Another interesting feature is the programmable limitation of the luma comb amount; proper limitation, associated to adequate luma peaking, gives rise to an enhanced 2-D resolution homogeneity. This limitation is set by the parameter CLIM, ranging from 0 (no limitation) to 31 (max. limitation).

The DAA parameter (1:off , 0:on) is used to disable/enable a very efficient built-in “rain effect” suppressor; many comb filters show this side effect which gives some vertical correlation to a 2-D uniform random area, due to the vertical filtering. This unnatural-looking phenomenon is mostly visible on tuner images, since they are always corrupted by some noise; and this looks like rain.

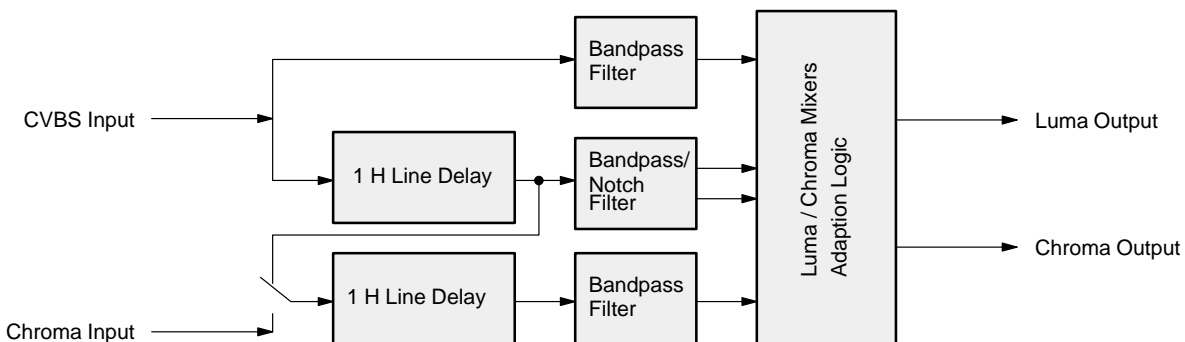

Fig. 2–3: Block diagram of the adaptive comb filter

2.3. Color Decoder

In this block, the standard luma/chroma separation and multi-standard color demodulation is carried out. The color demodulation uses an asynchronous clock, thus allowing a unified architecture for all color standards.

A block diagram of the color decoder is shown in Fig. 2–5. The luma as well as the chroma processing, is shown here. The color decoder provides also some special modes, e.g. wide band chroma format which is intended for S-VHS wide bandwidth chroma.

If the adaptive comb filter is used for luma chroma separation, the color decoder uses the S-VHS mode processing. The output of the color decoder is $Y C_r C_b$ in a 4:2:2 format.

2.3.1. IF-Compensation

With off-air or mistuned reception, any attenuation at higher frequencies or asymmetry around the color sub-carrier is compensated. Four different settings of the IF-compensation are possible:

- flat (no compensation)
- 6 dB/octave
- 12 dB/octave
- 10 dB/MHz

The last setting gives a very large boost to high frequencies. It is provided for SECAM signals that are decoded using a SAW filter specified originally for the PAL standard.

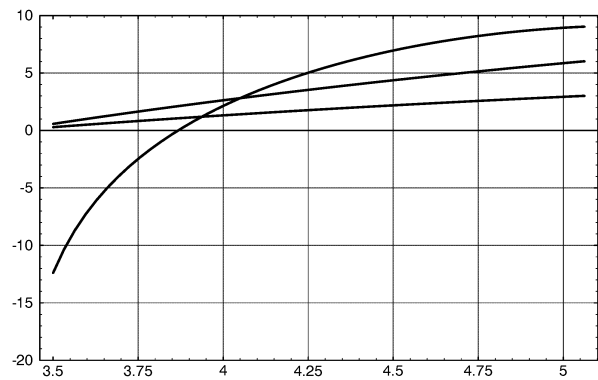

Fig. 2–4: Frequency response of chroma IF-compensation

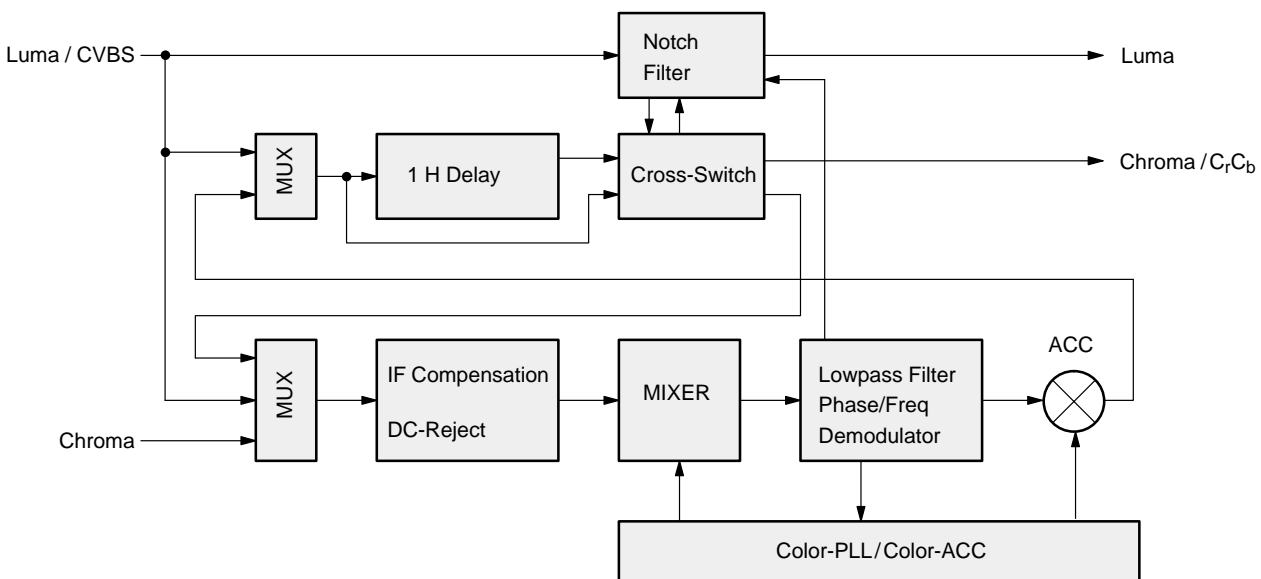

Fig. 2–5: Color decoder

2.3.2. Demodulator

The entire signal (which might still contain luma) is now quadrature-mixed to the baseband. The mixing frequency is equal to the subcarrier for PAL and NTSC, thus achieving the chroma demodulation. For SECAM, the mixing frequency is 4.286 MHz giving the quadrature baseband components of the FM modulated chroma. After the mixer, a lowpass filter selects the chroma components; a downsampling stage converts the color difference signals to a multiplexed half rate data stream.

The subcarrier frequency in the demodulator is generated by direct digital synthesis; therefore, substandards such as PAL 3.58 or NTSC 4.43 can also be demodulated.

2.3.3. Chrominance Filter

The demodulation is followed by a lowpass filter for the color difference signals for PAL/NTSC. SECAM requires a modified lowpass function with bell-filter characteristic. At the output of the lowpass filter, all luma information is eliminated.

The lowpass filters are calculated in time multiplex for the two color signals. Three bandwidth settings (narrow, normal, broad) are available for each standard. For PAL/NTSC, a wide band chroma filter can be selected. This filter is intended for high bandwidth chroma signals, e.g. a nonstandard wide bandwidth S-VHS signal.

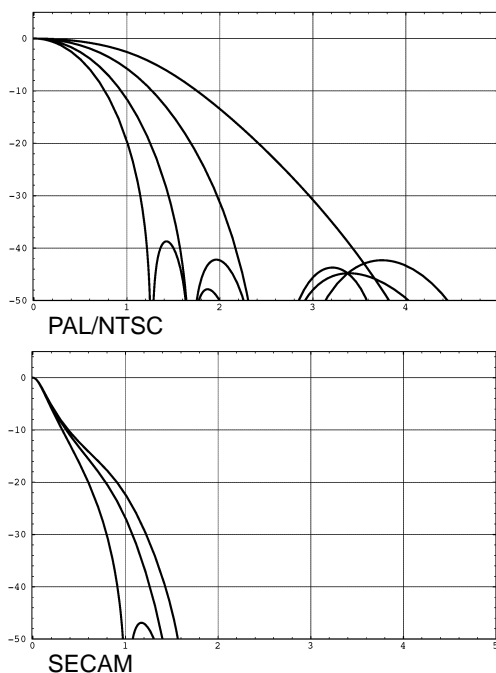

Fig. 2-6: Frequency response of chroma filters

2.3.4. Frequency Demodulator

The frequency demodulator for demodulating the SECAM signal is implemented as a CORDIC-structure. It calculates the phase and magnitude of the quadrature components by coordinate rotation.

The phase output of the CORDIC processor is differentiated to obtain the demodulated frequency. After the deemphasis filter, the D_r and D_b signals are scaled to standard $C_r C_b$ amplitudes and fed to the crossover-switch.

2.3.5. Burst Detection

In the PAL/NTSC-system the burst is the reference for the color signal. The phase and magnitude outputs of the CORDIC are gated with the color key and used for controlling the phase-lock-loop (APC) of the demodulator and the automatic color control (ACC) in PAL/NTSC. The ACC has a control range of +30...-6 dB.

For SECAM decoding, the frequency of the burst is measured. Thus, the current chroma carrier frequency can be identified and is used to control the SECAM processing. The burst measurements also control the color killer operation; they can be used for automatic standard detection as well.

2.3.6. Color Killer Operation

The color killer uses the burst-phase/burst-frequency measurement to identify a PAL/NTSC or SECAM color signal. For PAL/NTSC, the color is switched off (killed) as long as the color subcarrier PLL is not locked. For SECAM, the killer is controlled by the toggle of the burst frequency. The burst amplitude measurement is used to switch-off the color if the burst amplitude is below a programmable threshold. Thus, color will be killed for very noisy signals. The color amplitude killer has a programmable hysteresis.

2.3.7. PAL Compensation/1-H Comb Filter

The color decoder uses one fully integrated delay line. Only active video is stored.

The delay line application depends on the color standard:

- NTSC: 1-H comb filter **or** color compensation
- PAL: color compensation
- SECAM: crossover-switch

In the NTSC compensated mode, Fig. 2-7 c), the color signal is averaged for two adjacent lines. Thus, cross-color distortion and chroma noise is reduced. In the NTSC combfilter mode, Fig. 2-7 d), the delay line is in the composite signal path, thus allowing reduction of

cross-color components, as well as cross-luminance. The loss of vertical resolution in the luminance channel is compensated by adding the vertical detail signal with removed color information.

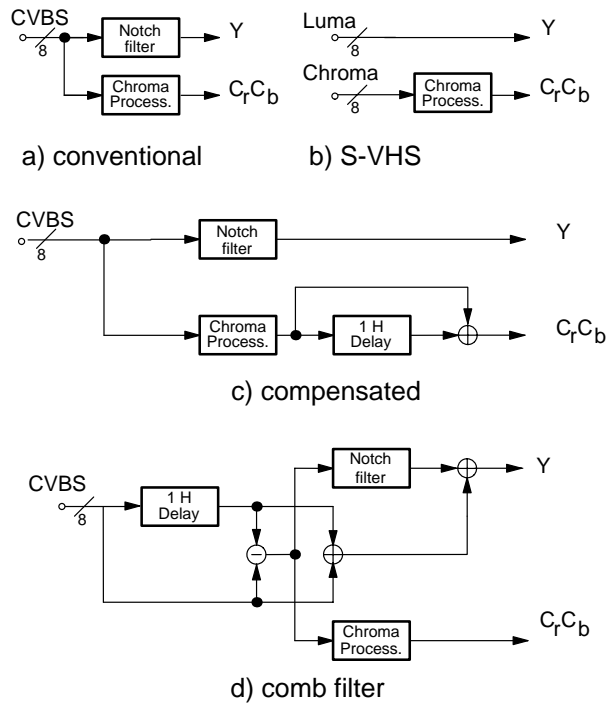

Fig. 2-7: NTSC color decoding options

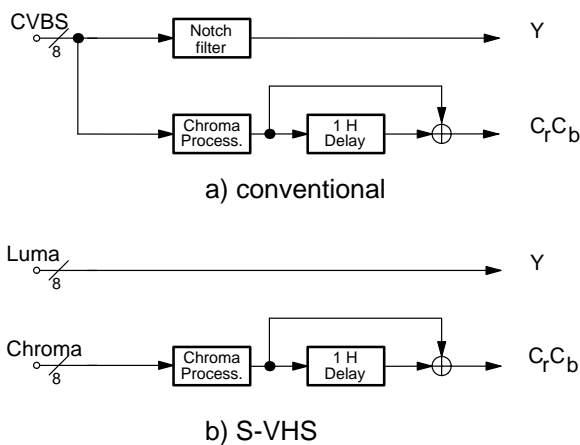

Fig. 2-8: PAL color decoding options

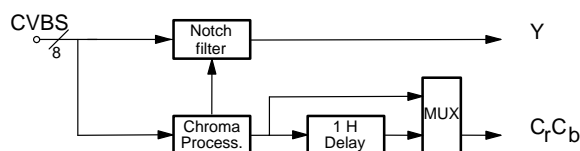
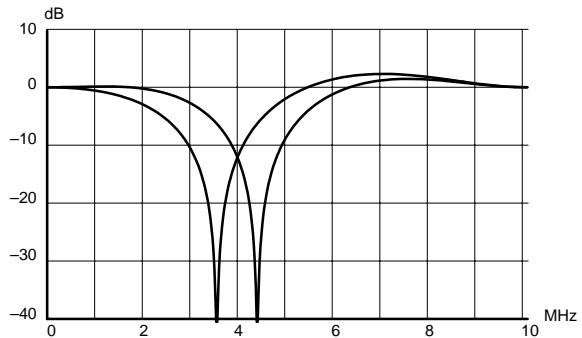

Fig. 2-9: SECAM color decoding

2.3.8. Luminance Notch Filter

If a composite video signal is applied, the color information is suppressed by a programmable notch filter. The position of the filter center frequency depends on the subcarrier frequency for PAL/NTSC. For SECAM, the notch is directly controlled by the chroma carrier frequency. This considerably reduces the cross-luminance. The frequency responses for all three systems are shown in Fig. 2-10.



PAL/NTSC notch filter

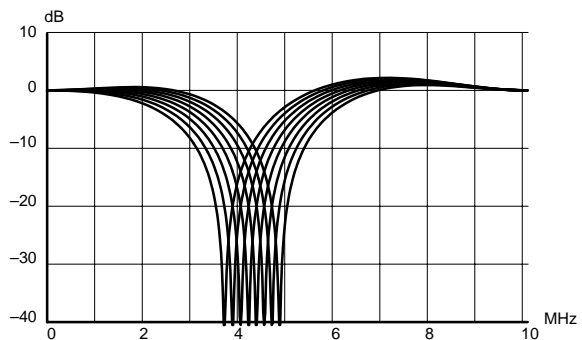

SECAM notch filter

Fig. 2-10: Frequency responses of the luma notch filter for PAL, NTSC, and SECAM

2.3.9. Skew Filtering

The system clock is free-running and not locked to the TV line frequency. Therefore, the ADC sampling pattern is not orthogonal. The decoded YCrCb signals are converted to an orthogonal sampling raster by the skew filters, which are part of the scaler block.

The skew filters allow the application of a group delay to the input signals without introducing waveform or frequency response distortion.

The amount of phase shift of this filter is controlled by the horizontal PLL1. The accuracy of the filters is 1/32 clocks for luminance and 1/4 clocks for chroma. Thus the 4:2:2 YCrCb data is in an orthogonal pixel format even in the case of nonstandard input signals such as VCR.

2.4. Horizontal Scaler

The 4:2:2 YCrCb signal from the color decoder is processed by the horizontal scaler. The scaler block allows a linear or nonlinear horizontal scaling of the input video signal in the range of 0.25 to 4. Nonlinear scaling, also called “panorama vision”, provides a geometrical distortion of the input picture. It is used to fit a picture with 4:3 format on a 16:9 screen by stretching the picture geometry at the borders. Also, the inverse effect can be produced by the scaler. A summary of scaler modes is given in Table 2–2.

The scaler contains a programmable decimation filter, a 1-line FIFO memory, and a programmable interpolation filter. The scaler input filter is also used for pixel skew correction, see 2.3.9. The decimator/interpolator structure allows optimal use of the FIFO memory. The controlling of the scaler is done by the internal Fast Processor.

Table 2–2: Scaler modes

| Mode | Scale Factor | Description |
|---------------------------|---------------------|--|
| Compression 4:3 → 16:9 | 0.75 linear | 4:3 source displayed on a 16:9 tube, with side panels |
| Panorama 4:3 → 16:9 | non-linear compr | 4:3 source displayed on a 16:9 tube, Borders distorted |
| Zoom 4:3 → 4:3 | 1.33 linear | Letterbox source (PAL+) displayed on a 4:3 tube, vertical overscan with cropping of side panels |
| Panorama 4:3 → 4:3 | non-linear zoom | Letterbox source (PAL+) displayed on a 4:3 tube, vertical overscan, borders distorted, no cropping |

2.5. Black-Line Detector

In case of a letterbox format input video, e.g. Cinema-scope, PAL+ etc., black areas at the upper and lower part of the picture are visible. It is suitable to remove or reduce these areas by a vertical zoom and/or shift operation.

The VDP 31xxB supports this feature by a letterbox detector. The circuitry detects black video lines by measuring the signal amplitude during active video. For every field the number of black lines at the upper and lower part of the picture are measured, compared to the previous measurement and the minima are stored in the I²C-register BLKLIN. To adjust the picture amplitude, the external controller reads this register, calculates the vertical scaling coefficient and transfers the new settings, e.g. vertical sawtooth parameters, horizontal scaling coefficient etc., to the VDP.

Letterbox signals containing logos on the left or right side of the black areas are processed as black lines, while subtitles, inserted in the black areas, are processed as non-black lines. Therefore the subtitles are visible on the screen. To suppress the subtitles, the vertical zoom coefficient is calculated by selecting the larger number of black lines only. Dark video scenes with a low contrast level compared to the letterbox area are indicated by the BLKPIC bit.

2.6. Test Pattern Generator

The YCrCb outputs of the front-end can be switched to a test mode where YCrCb data are generated digitally in the VDP 31xxB. Test patterns include luma/chroma ramps, flat fields and a pseudo color bar pattern.

2.7. Video Sync Processing

Fig. 2–11 shows a block diagram of the front-end sync processing. To extract the sync information from the video signal, a linear phase lowpass filter eliminates all noise and video contents above 1 MHz. The sync is separated by a slicer; the sync phase is measured. A variable window can be selected to improve the noise immunity of the slicer. The phase comparator measures the falling edge of sync, as well as the integrated sync pulse.

The sync phase error is filtered by a phase-locked loop that is computed by the FP. All timing in the front-end is derived from a counter that is part of this PLL, and it thus counts synchronously to the video signal.

A separate hardware block measures the signal back porch and also allows gathering the maximum/minimum of the video signal. This information is processed by the FP and used for gain control and clamping.

For vertical sync separation, the sliced video signal is integrated. The FP uses the integrator value to derive vertical sync and field information.

The information extracted by the video sync processing is multiplexed onto the hardware front sync signal (FSY) and is distributed to the rest of the video processing system. The format of the front sync signal is given in Fig. 2–12.

The data for the vertical deflection, the sawtooth, and the East-West correction signal is calculated by the VDP 31xxB. The data is buffered in a FIFO and transferred to the back-end by a single wire interface.

Frequency and phase characteristics of the analog video signal are derived from PLL1. The results are fed to the scaler unit for data interpolation and orthogonalization and to the clock synthesizer for line-locked clock generation. Horizontal and vertical syncs are latched with the line-locked clock.

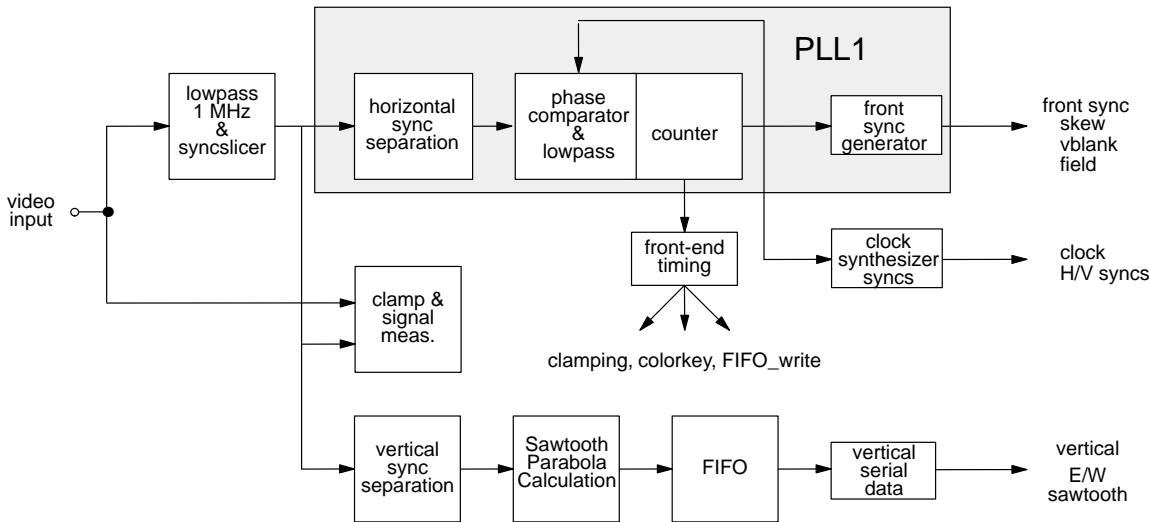

Fig. 2–11: Sync separation block diagram

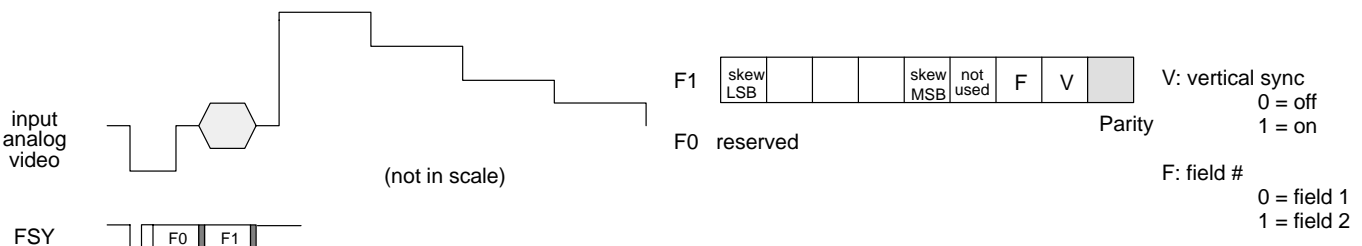

Fig. 2–12: Front sync format

2.8.3. Dynamic Peaking

Especially with decoded composite signals and notch filter luminance separation, as input signals, it is necessary to improve the luminance frequency characteristics. With transparent, high-bandwidth signals, it is sometimes desirable to soften the image.

In the VDP 31xxB, the luma response is improved by 'dynamic' peaking. The algorithm has been optimized regarding step and frequency response. It adapts to the amplitude of the high frequency part. Small AC amplitudes are processed, while large AC amplitudes stay nearly unmodified.

The dynamic range can be adjusted from -14 to +14 dB for small high frequency signals. There is separate adjustment for signal overshoot and for signal undershoot. For large signals, the dynamic range is limited by a non-linear function that does not create any visible alias components. The peaking can be switched over to "softening" by inverting the peaking term by software.

The center frequency of the peaking filter is switchable from 2.5 MHz to 3.2 MHz. For S-VHS and for notch filter color decoding, the total system frequency responses for both PAL and NTSC are shown in figure 2-16.

Transients, produced by the dynamic peaking when switching video source signals, can be suppressed via the priority bus.

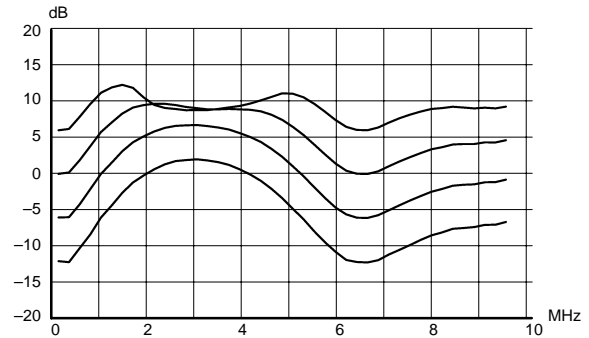

Fig. 2-15: Dynamic peaking frequency response

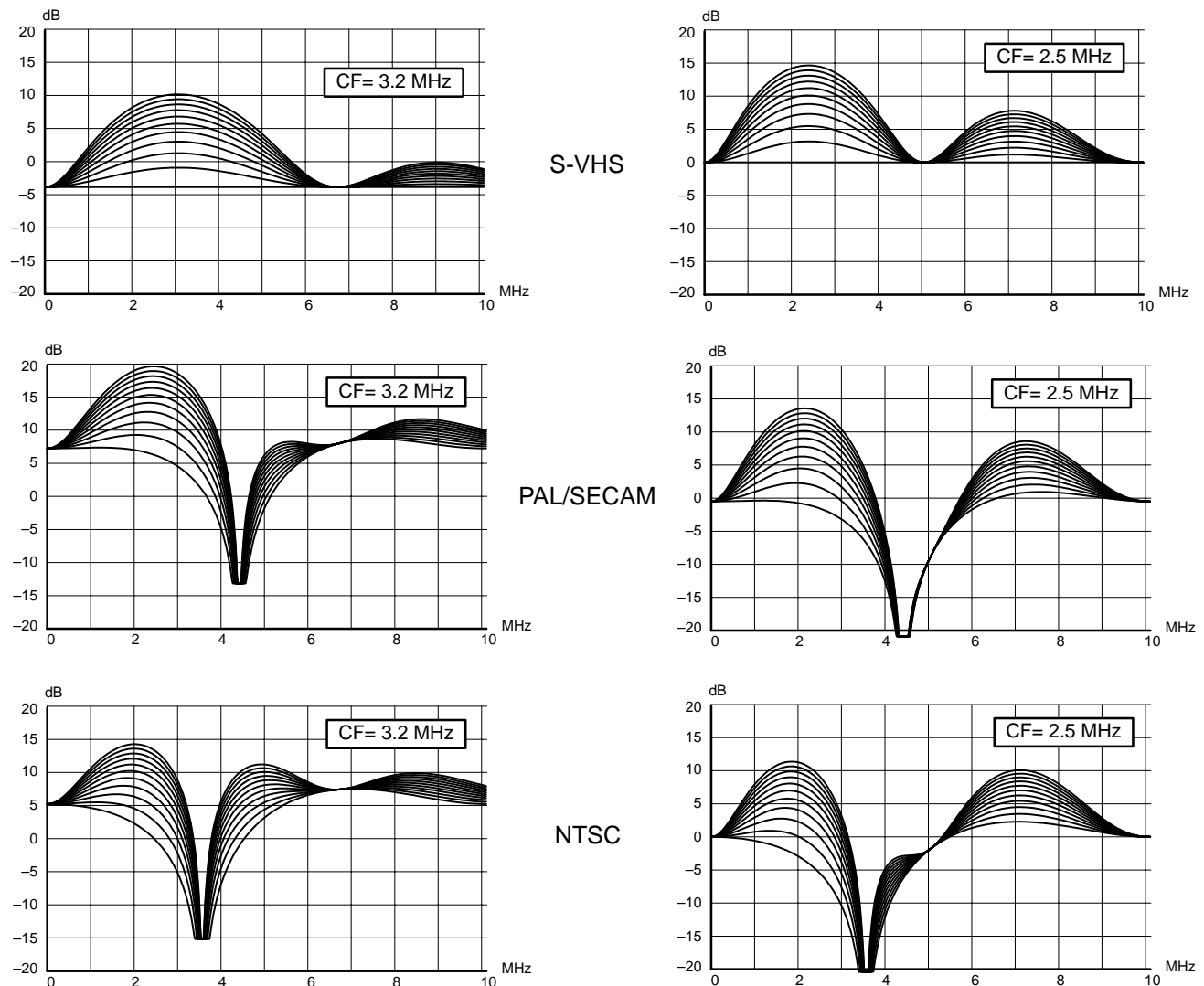

Fig. 2-16: Total frequency response for peaking filter and S-VHS, PAL, NTSC

2.8.4. Digital Brightness Adjustment

The DC-level of the luminance signal can be adjusted by adding an 8-bit number in the luminance signal path in front of the softlimiter.

With a contrast adjustment of 32 (gain = 1) the signal can be shifted by ± 100%. After the brightness addition, the negative going signals are limited to zero. It is desirable to keep a small positive offset with the signal to prevent undershoots produced by the peaking from being cut. The digital brightness adjustment is separate for main and side picture.

2.8.5. Soft Limiter

The dynamic range of the processed luma signal must be limited to prevent the CRT from overload. An appropriate headroom for contrast, peaking and brightness can be adjusted by the TV manufacturer according to the CRT characteristics. All signals above this limit will be 'soft'-clipped. A characteristic diagram of the soft limiter is shown in Fig. 2-17. The total limiter consists of three parts:

Part 1 includes adjustable tilt point and gain. The gain before the tilt value is 1. Above the tilt value, a part (0...15/16) of the input signal is subtracted from the input

signal itself. Therefore, the gain is adjustable from 16/16 to 1/16, when the slope value varies from 0 to 15. The tilt value can be adjusted from 0 to 511.

Part 2 has the same characteristics as part 1. The subtracting part is also relative to the input signal, so the total differential gain will become negative if the sum of slope 1 and slope 2 is greater than 16 and the input signal is above the both tilt values (see characteristics).

Finally, the output signal of the soft limiter will be clipped by a hard limiter adjustable from 256 to 511.

2.8.6. Chroma Input

The chroma input signal is a multiplexed C_R and C_B signal in 8-bit binary offset code. It can be switched between normal and inverted signal and between two's complement and binary offset code. The delay in respect to the luminance input can be adjusted in 5 steps within a range of ± 2 clock periods.

2.8.7. Chroma Interpolation

A linear phase interpolator is used to convert the chroma sampling rate from 10.125 MHz (4:2:2) to 20.25 MHz (4:4:4). All further processing is carried out at the full sampling rate.

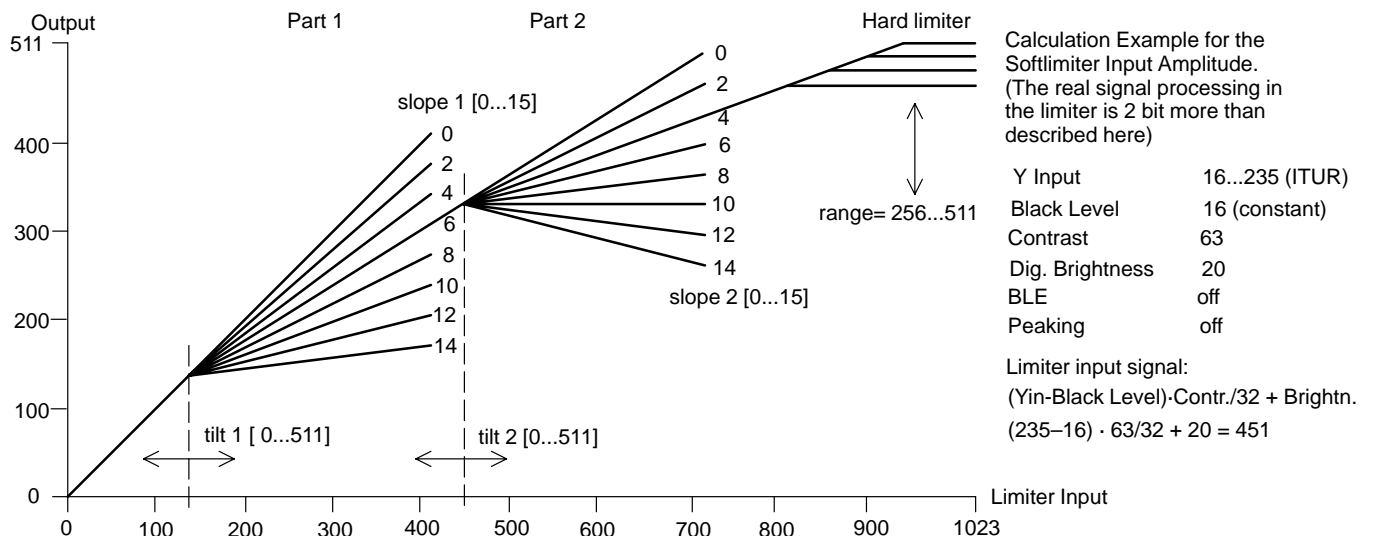

Fig. 2-17: Characteristic of soft limiter a and b and hard limiter

2.8.8. Chroma Transient Improvement

The intention of this block is to enhance the chroma resolution. A correction signal is calculated by differentiation of the color difference signals. The differentiation can be selected according to the signal bandwidth, e.g. for PAL/NTSC/SECAM or digital component signals, respectively. The amplitude of the correction signal is adjustable. Small noise amplitudes in the correction signal are suppressed by an adjustable coring circuit. To eliminate 'wrong colors', which are caused by over and undershoots at the chroma transition, the sharpened chroma signals are limited to a proper value automatically.

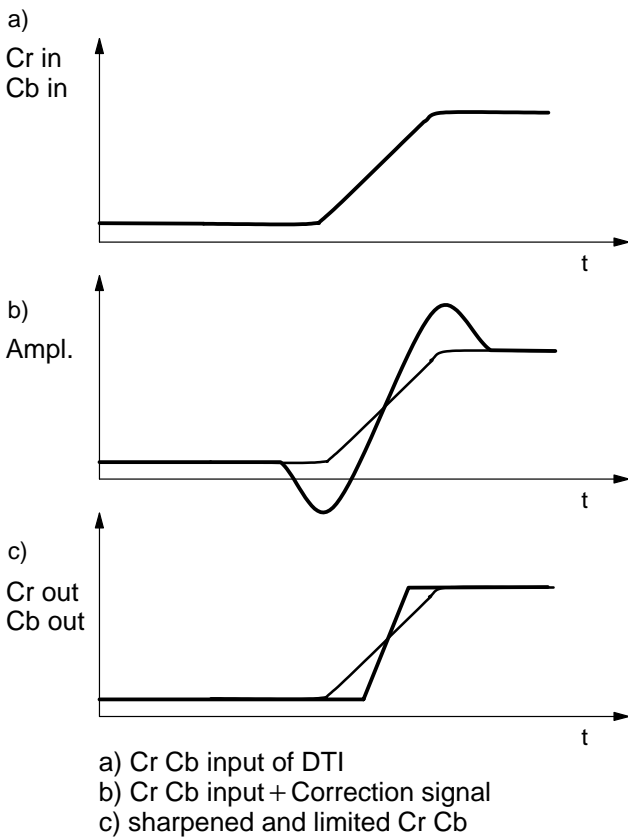

Fig. 2-18: Digital Color Transient Improvement

2.8.9. Inverse Matrix

A 6-multiplier matrix transcodes the Cr and Cb signals to R-Y, B-Y, and G-Y. The multipliers are also used to adjust color saturation in the range of 0 to 2. The coefficients are signed and have a resolution of 9 bits. There are separate matrix coefficients for main and side pictures. The matrix computes:

$$\begin{aligned} R-Y &= MR1*Cb + MR2*Cr \\ G-Y &= MG1*Cb + MG2*Cr \\ B-Y &= MB1*Cb + MB2*Cr \end{aligned}$$

The initialization values for the matrix are computed from the standard ITUR (CCIR) matrix:

$$\begin{pmatrix} R \\ G \\ B \end{pmatrix} = \begin{pmatrix} 1 & 0 & 1.402 \\ 1 & -0.345 & -0.713 \\ 1 & 1.773 & 0 \end{pmatrix} \begin{pmatrix} Y \\ Cb \\ Cr \end{pmatrix}$$

For a contrast setting of CTM = 32, the matrix values are scaled by a factor of 64, see also table 3-1.

2.8.10. RGB Processing

After adding the post-processed luma, the digital RGB signals are limited to 10 bits. Three multipliers are used to digitally adjust the white drive. Using the same multipliers an average beam current limiter is implemented. See also section 2.9.1. 'CRT Measurement and Control'.

2.8.11. OSD Color Lookup Table

The VDP 31xxB has five input lines for an OSD signal. This signal forms a 5-bit address for a color look-up table (CLUT). The CLUT is a memory with 32 words where each word holds a RGB value.

Bits 0 to 3 (bit 4 = 0) form the addresses for the ROM part of the OSD, which generates full RGB signals (bit 0 to 2) and half-contrast RGB signals (bit 3).

Bit 4 addresses the RAM part of the OSD with 16 freely programmable colors, addressable with bit 0 to 3. The programming is done via the I²C-bus.

The amplitude of the CLUT output signals can be adjusted separately for R, G and B via the I²C-bus. The switchover between video RGB and OSD RGB is done via the Priority bus.

2.8.12. Picture Frame Generator

When the picture does not fill the total screen (height or width too small) it is surrounded with black areas. These areas (and more) can be colored with the picture frame generator. This is done by switching over the RGB signal from the matrix to the signal from the OSD color look-up table.

The width of each area (left, right, upper, lower) can be adjusted separately. The generator starts on the right, respectively lower side of the screen and stops on the left, respectively upper side of the screen. This means, it runs during horizontal, respectively vertical flyback. The color of the complete border can be stored in the programmable OSD color look-up table in a separate address. The format is 3 × 4 bit RGB. The contrast can be adjusted separately.

The picture frame generator includes a priority master circuit. Its priority is programmable and the border is generated only if the priority is higher than the priority at the PRIO bus. Therefore the border can be underlay or overlay depending on the picture source.

2.8.13. Priority Codec

The priority decoder has three input lines for up to eight priorities. The highest priority is all three lines at low level. A 5-bit information is attached to each priority (see table 3–1 ‘Priority Bus’). These bits are programmable via the I²C-bus and have the following meanings:

- one of two contrast, brightness and matrix values for main and side picture
- RGB from video signal or color look-up table
- disable/enable black level expander
- disable/enable peaking transient suppression when signal is switched
- disable/enable analog fast blank input 1
- disable/enable analog fast blank input 2

2.8.14. Scan Velocity Modulation

The RGB input signal of the SVM is converted to Y in a simple matrix. Then the Y signal is differentiated by a filter of the transfer function $1-Z^{-N}$, where N is programmable from 1 to 6. With a coring, some noise can be suppressed. This is followed by a gain adjustment and an adjustable limiter. The analog output signal is generated by an 8-bit D/A converter.

The signal delay can be adjusted by ±3.5 clocks in half-clock steps. For the gain and filter adjustment there are two parameter sets. The switching between these two sets is done with the same RGB switch signal that is used for switching between video-RGB and OSD-RGB for the RGB outputs. (See Fig. 2–19).

2.8.15. Display Phase Shifter

A phase shifter is used to partially compensate the phase differences between the video source and the fly-back signal. By using the described clock system, this phase shifter works with an accuracy of approximately 1 ns. It has a range of 1 clock period which is equivalent to ±24.7 ns at 20.25 MHz. The large amount of phase shift (full clock periods) is realized in the front-end circuit.

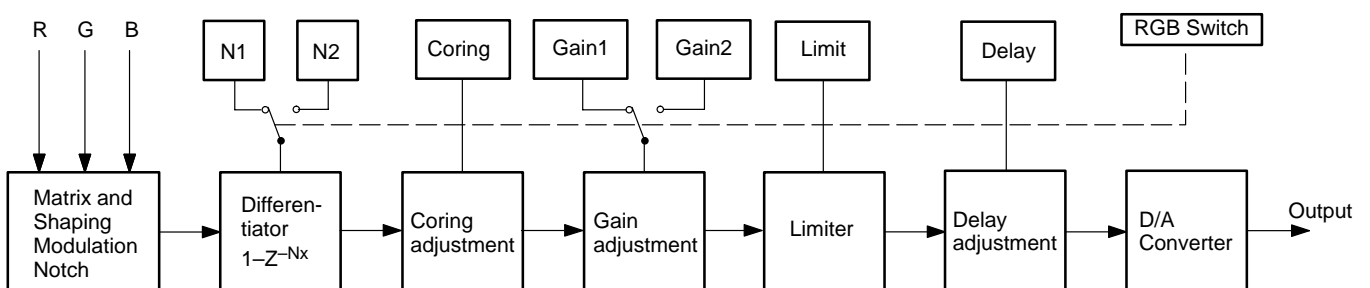

Fig. 2–19: SVM block diagram

2.9. Analog Back End

The digital RGB signals are converted to analog RGBs using three video digital to analog converters (DAC) with 10-bit resolution. An analog brightness value is provided by three additional DACs. The adjustment range is 40% of the full RGB range.

Controlling the whitedrive/analog brightness and also the external contrast and brightness adjustments is done via the Fast Processor, located in the front-end. Control of the cutoff DACs is via I²C-bus registers.

Finally cutoff and blanking values are added to the RGB signals. Cutoff (dark current) is provided by three 9-bit DACs. The adjustment range is 60% of full scale RGB range.

The analog RGB-outputs are current outputs with current-sink characteristics. The maximum current drawn by the output stage is obtained with peak white RGB. An external half contrast signal can be used to reduce the output current of the RGB outputs to 50%.

2.9.1. CRT Measurement and Control

The display processor is equipped with an 8-bit PDM-ADC for all measuring purposes. The ADC is connected to the sense input pin, the input range is 0 to 1.5V. The bandwidth of the PDM filter can be selected; it is 40/80 kHz for small/large bandwidth setting. The input impedance is more than 1 MΩ.

Cutoff and white drive current measurement are carried out during the vertical blanking interval. They always use the small bandwidth setting. The current range for the cutoff measurement is set by connecting a sense resistor to the MADC input. For the whitedrive measurement, the range is set by using another sense resistor and the range select switch 2 output pin (RSW2). During the active picture, the minimum and maximum beam current is measured. The measurement range can be set by using the range select switch 1 pin (RSW1) as shown in Fig. 2–21 and Fig. 2–22. The timing window of this measurement is programmable. The intention is to automatically detect letterbox transmission or to measure the actual beam current. All control loops are closed via the external control microprocessor.

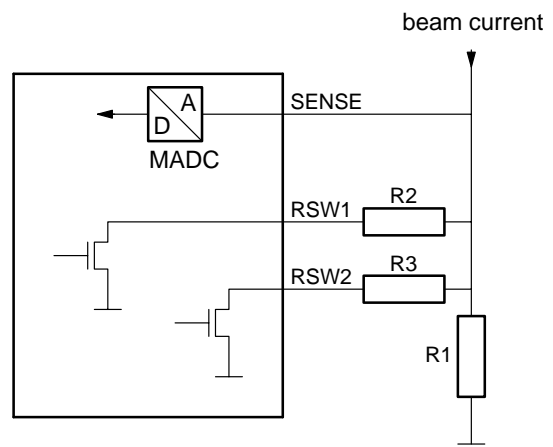

Fig. 2–21: MADC Range Switches

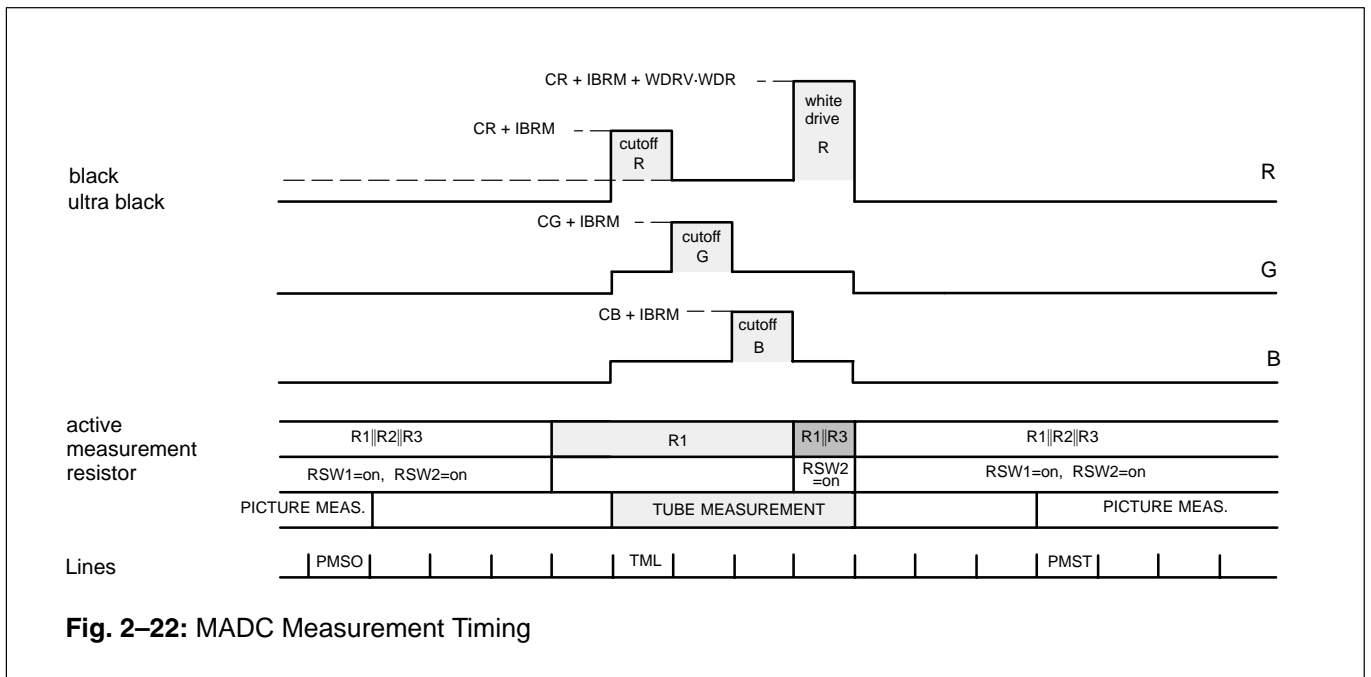

Fig. 2–22: MADC Measurement Timing

In each field two sets of measurements can be taken:

- a) The picture tube measurement returns results for
- cutoff R
 - cutoff G
 - cutoff B
 - white drive R or G or B (sequentially)

b) The picture measurement returns data on

- active picture maximum current
- active picture minimum current

The tube measurement is automatically started when the cutoff blue result register is read. Cutoff control for RGB requires one field only while a complete white-drive control requires three fields. If the measurement mode is set to 'offset check', a measurement cycle is run with the cutoff/whitedrive signals set to zero. This allows to compensate the MADC offset as well as input the leakage currents. During cutoff and whitedrive measurements, the average beam current limiter function (ref. 2.9.3.) is switched off and a programmable value is used for the brightness setting. The start line of the tube measurement can be programmed via I²C-bus, the first line used for the measurement, i.e. measurement of cutoff red, is 2 lines after the programmed start line.

The picture measurement must be enabled by the control microprocessor after reading the min./max. result registers. If a '1' is written into bit 2 in subaddress 25, the measurement runs for one field. For the next measurement a '1' has to be written again. The measurement is always started at the beginning of active video.

The vertical timing for the picture measurement is programmable, and may even be a single line. Also the signal bandwidth is switchable for the picture measurement.

Two horizontal windows are available for the picture measurement. The large window is active for the entire active line. Tube measurement is always carried out with the small window. Measurement windows for picture and tube measurement are shown in Figure 2–23.

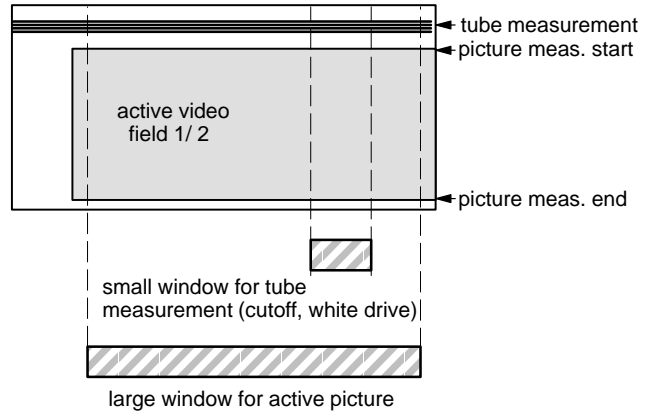

Fig. 2–23: Windows for tube and picture measurements

2.9.2. SCART Output Signal

The RGB output of the VDP 31xxB can also be used to drive a SCART output. In the case of the SCART signal, the parameter CLMPR (clamping reference) has to be set to 1. Then, during blanking, the RGB outputs are automatically set to 50% of the maximum brightness. The DC offset values can be adjusted with the cutoff parameters CR, CG, and CB. The amplitudes can be adjusted with the drive parameters WDR, WDG, and WDB.

2.9.3. Average Beam Current Limiter

The average beam current limiter (BCL) uses the sense input for the beam current measurement. The BCL uses a different filter to average the beam current during the active picture. The filter bandwidth is approx. 2 kHz. The beam current limiter has an automatic offset adjustment that is active two lines before the first cutoff measurement line.

The beam current limiter function is located in the front-end. The data exchange between the front-end and the back-end is done via a single-wire serial interface.

The beam current limiter allows the setting of a threshold current. If the beam current is above the threshold, the excess current is low-pass filtered and used to attenuate the RGB outputs by adjusting the white-drive multipliers for the internal (digital) RGB signals, and the analog contrast multipliers for the analog RGB inputs, respectively. The lower limit of the attenuator is programmable, thus a minimum contrast can always be set. During the tube measurement, the ABL attenuation is switched off. After the white drive measurement line it takes 3 lines to switch back to BCL limited drives and brightness.

Typical characteristics of the ABL for different loop gains are shown in Fig. 2–24; for this example the tube has been assumed to have square law characteristics.

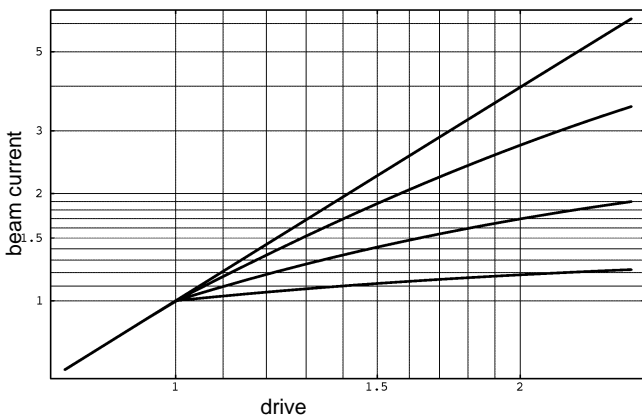

Fig. 2–24: Beam current limiter characteristics: beam current output vs. drive
BCL threshold: 1

2.9.4. Analog RGB Insertion

The VDP 31xxB allows insertion of 2 external analog RGB signals. Each RGB signal is key-clamped and inserted into the main RGB by the fast blank switch. The selected external RGB input is virtually handled as a priority bus signal. Thus, it can be overlaid or underlaid to the digital picture. The external RGB signals can be adjusted independently as regards DC-level (brightness) and magnitude (contrast).

Which analog RGB input is selected depends on the fast blank input signals and the programming of a number of I²C-bus register settings (see Table 2–3 and Fig. 2–25). Both fast blank inputs must be either active-low or active-high.

All signals for analog RGB insertion (RIN1/2, GIN1/2, BIN1/2, FBLIN1/2, HCS) must be synchronized to the horizontal flyback, otherwise a horizontal jitter will be visible. The VDP 31xxB has no means for timing correction of the analog RGB input signals.

Table 2–3: RGB Input Selection

FBFOH1 = 0, FBFOH2 = 0, FBFOL1 = 0, FBFOL2 = 0

| FBLIN1 | FBLIN2 | FBPOL | FBPRIO | RGB output |
|--------|--------|-------|--------|-------------|
| 0 | 0 | 0 | x | Video |
| 0 | 1 | 0 | x | RGB input 2 |
| 1 | 0 | 0 | x | RGB input 1 |
| 1 | 1 | 0 | 0 | RGB input 1 |
| 1 | 1 | 0 | 1 | RGB input 2 |
| 0 | 0 | 1 | 0 | RGB input 1 |
| 0 | 0 | 1 | 1 | RGB input 2 |
| 0 | 1 | 1 | x | RGB input 1 |
| 1 | 0 | 1 | x | RGB input 2 |
| 1 | 1 | 1 | x | Video |

2.9.5. Fast Blank Monitor

The presence of external analog RGB sources can be detected by means of a fast blank monitor. The status of the selected fast blank input can be monitored via an I²C bus register. There is a 2 bit information, giving static and dynamic indication of a fast blank signal. The static bit is directly reading the fast blank input line, whereas the dynamic bit is reading the status of a flip-flop triggered by the negative edge of the fast blank signal.

With this monitor logic it is possible to detect if there is an external RGB source active and if it is a full screen insertion or only a box. The monitor logic is connected directly to the FBLIN1 or FBLIN2 pin. Selection is done via I²C bus register.

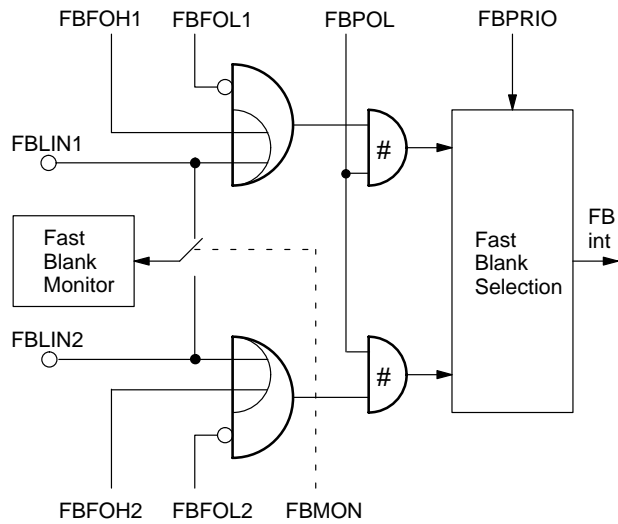

Fig. 2–25: Fast Blank Selection Logic

2.9.6. Half Contrast Control

Insertion of transparent text pages or OSD onto the video picture is often difficult to read, especially if the video contrast is high. The VDP 31xxB allows contrast reduction of the video background by means of a half contrast input (HCS pin). This input can be supplied with a fast switching signal (similar to the fast blank input), typically defining a rectangular box in which the video picture is displayed with reduced contrast. The analog RGB inputs are still displayed with full contrast.

The HCS input is multiplexed with the PORT0 input/output on the same pin, selection is done via I²C-bus register. If the HCS input is selected, then the port function of this pin is disabled and writing data into PORT0 will have no effect. If the HCS input is not selected, the I²C-bus register bits HCSFOH and HCSPOL must be used to disable the half contrast function.

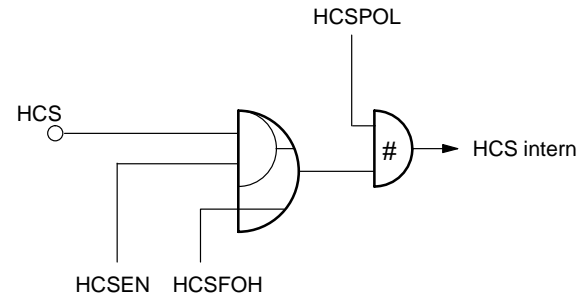

Fig. 2–26: Half Contrast Switch Logic

2.10. IO Port Expander

The VDP 31xxB provides a general purpose IO port to control and monitor up to seven external signals. The port direction is programmable for each bit individually. Via I²C bus register it is possible to write or read each port pin. Because of the relatively low I²C bus speed, only slow or static signals can be handled.

The port signals are multiplexed with other signals to minimize pin count. PORT0 is multiplexed with the HCS input signal, PORT1 is multiplexed with the FSU output signal, PORT[6:2] are multiplexed with the color bus input COLOR[4:0]. The pin configuration is programmable via I²C bus register. All register bits can be read back, the default configuration after reset is input on PORT[1:0] and COLOR[4:0] enabled.

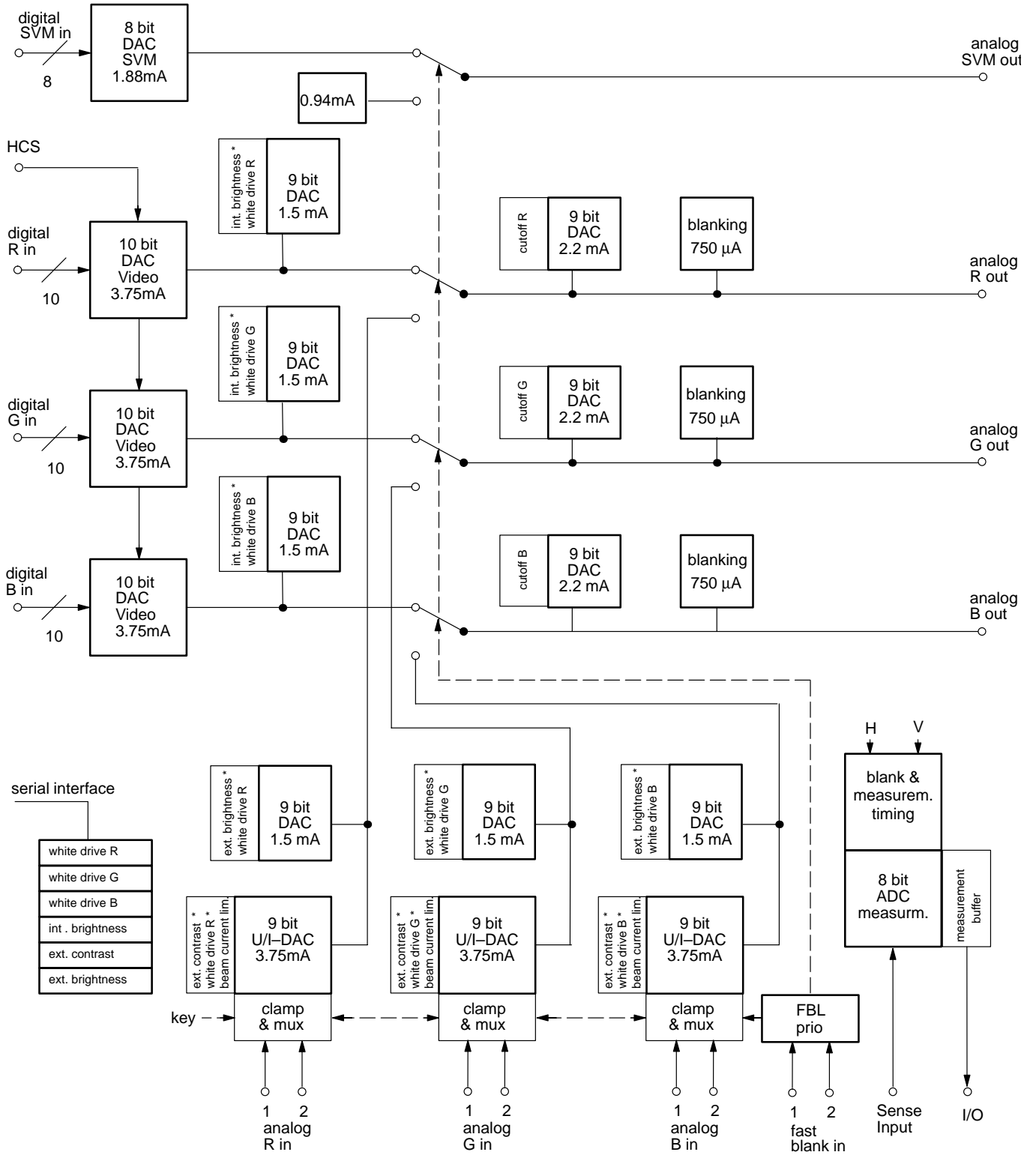

Fig. 2-27: Analog back-end

2.11. Synchronization and Deflection

The synchronization and deflection processing is distributed over front-end and back-end. The video clamping, horizontal and vertical sync separation and all video related timing information are processed in the front-end. Most of the processing that runs at the horizontal frequency is programmed on the internal Fast Processor (FP). Also the values for vertical and East/West deflection are calculated by the FP software.

The information extracted by the video sync processing is multiplexed onto the hardware front sync signal (FSY) and distributed internally to the rest of the video processing system.

The data for the vertical deflection, the sawtooth and the East/West correction signal is calculated in the front end. The data is transferred to the back-end by a single wire interface.

The display related synchronization, i.e. generation of horizontal and vertical drive and synchronization of horizontal and vertical drive to the video timing extracted in the front-end, are implemented in hardware in the back-end.

2.11.1. Deflection Processing

The deflection processing generates the signals for the horizontal and vertical drive (see Fig. 2–28). This block contains two phase-locked loops:

- PLL2 generates the horizontal and vertical timing, e.g. blanking, clamping and composite sync. Phase and frequency are synchronized by the front sync signal.
- PLL3 adjusts the phase of the horizontal drive pulse and compensates for the delay of the horizontal output stage. Phase and frequency are synchronized by the oscillator signal of PLL2.

The horizontal drive circuitry uses a digital sine wave generator to produce the exact (subclock) timing for the drive pulse. The generator runs at 1 MHz; in the output

stage the frequency is divided down to give drive-pulse period and width. In standby mode, the output stage is driven from an internal 1 MHz clock that is derived from the 5 MHz clock signal and a fixed drive pulse width is used. When the circuit is switched out of standby operation, the drive pulse width is programmable. The horizontal drive uses an open drain output transistor.

The Main Sync (MSY) signal that is generated from PLL3 is a multiplex of all display-related data (Fig. 2–29). This signal is intended for use by other processors, e.g. a PIP processor can use this signal to adjust to a certain display position.

2.11.2. Horizontal Phase Adjustment

This section describes a simple way to align PLL phases and the horizontal frame position.

1. The parameter NEWLIN in the front-end has to be adjusted. The minimum possible value is 34 (recommended for a standard 4:3 signal).
2. With HDRV, the duration of the horizontal drive pulse has to be adjusted.
3. With POFS2, the clamping pulse for the analog RGB input has to be adjusted to the correct position, e.g. the pedestal of the generator signal.
4. With POFS3, the horizontal position of the analog RGB signal (from SCART) has to be adjusted.
5. With HPOS, the digital RGB output signal (from VPC) has to be adjusted to the correct horizontal position.
6. With HBST and HBSO, the start and stop values for the horizontal blanking have to be adjusted.

Note: The processing delay of the internal digital video path differs depending on the comb filter option of the VDP 31xxB. The versions with comb filter have an additional delay of 35 clock cycles. Therefore, the timing of the external analog RGB signals has to be adjusted (with POFS2 and POFS3) according to the actual hardware version of the VDP 31xxB. The hardware version can be read out via FP subaddress 0xF1.

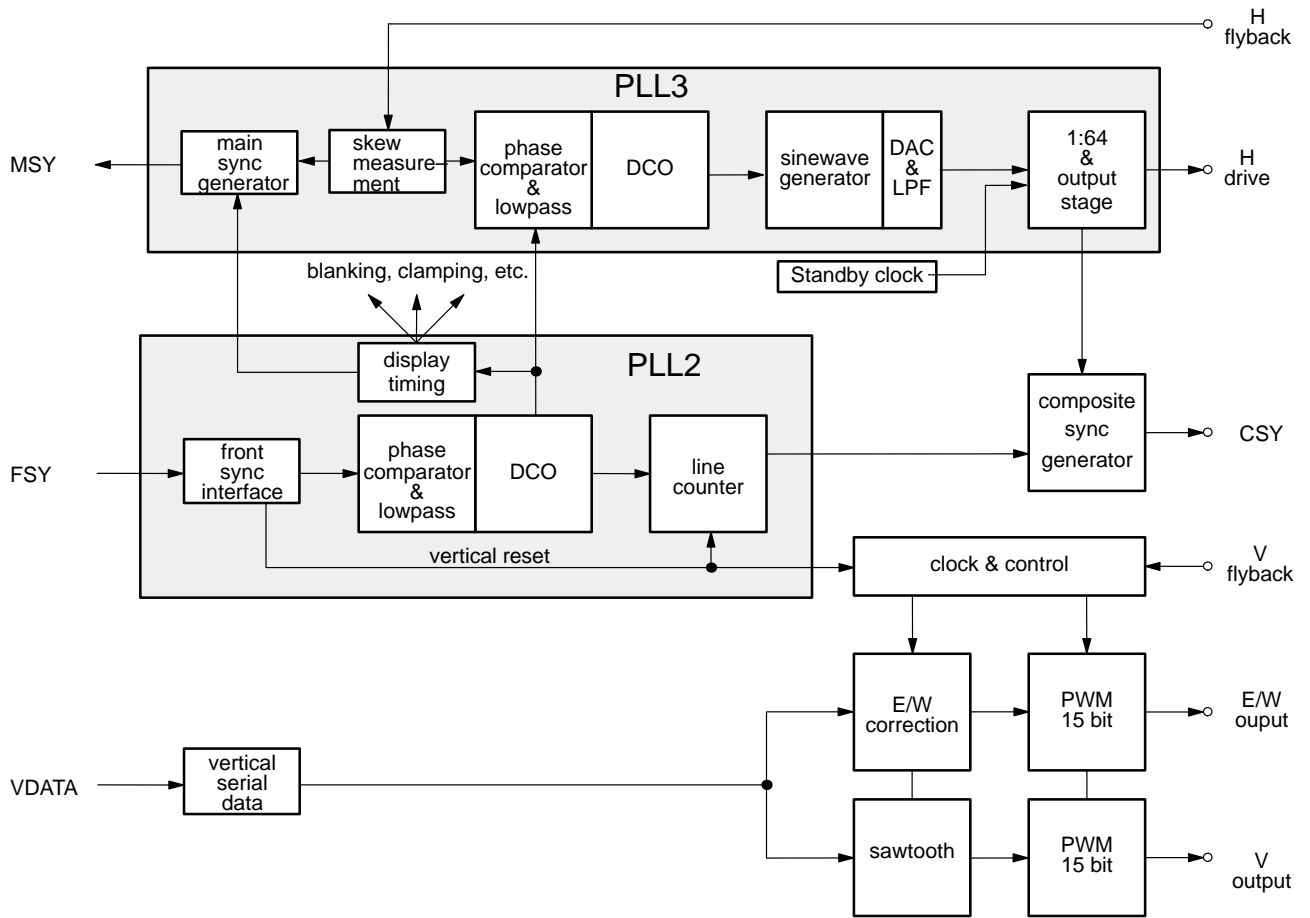

Fig. 2-28: Deflection processing block diagram

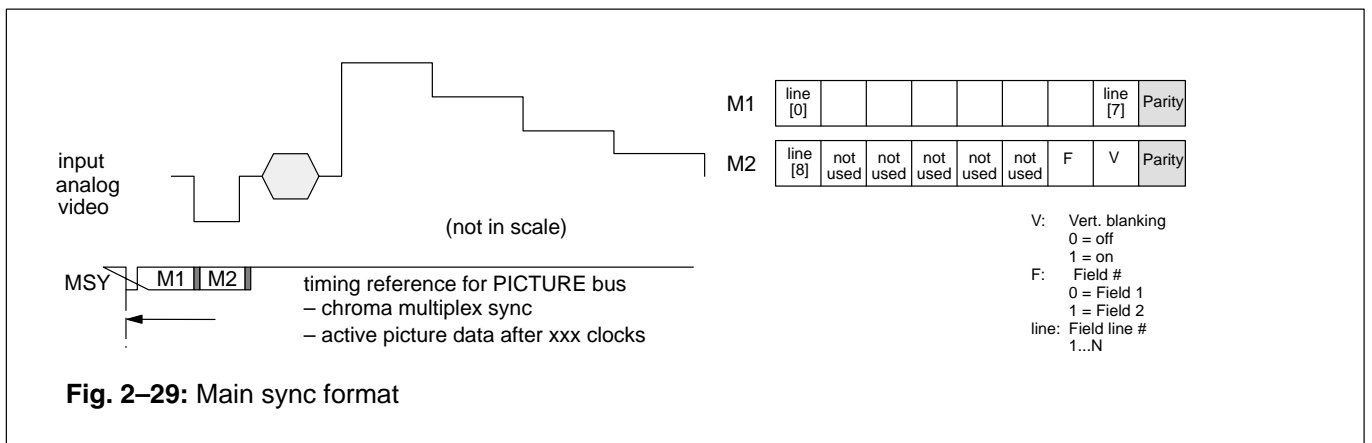

Fig. 2-29: Main sync format

2.11.3. Vertical and East/West Deflection

The calculations of the vertical and East/West deflection waveforms is done by the internal Fast Processor (FP). The algorithm uses a chain of accumulators to generate the required polynomial waveforms. To produce the deflection waveforms, the accumulators are initialized at the beginning of each field. The initialization values must be computed by the TV control processor and are written to the front-end once. The waveforms are described as polynomials in x, where x varies from 0 to 1 for one field.

$$P: a + b(x-0.5) + c(x-0.5)^2 + d(x-0.5)^3 + e(x-0.5)^4$$

The initialization values for the accumulators a0..a3 for vertical deflection and a0..a4 for East/West deflection are 12-bit values.

The vertical waveform can be scaled according the average beam current. This is used to compensate the effects of electric high tension changes due to beam current variations. In order to get a faster vertical retrace timing, the output impedance of the vertical D/A-converter can be reduced by 50% during the retrace.

Fig. 2-30 shows several vertical and East/West deflection waveforms. The polynomial coefficients are also stated.

2.11.4. Protection Circuitry

- Picture tube and drive stage protection is provided through the following measures:
- Vertical flyback protection input: this pin searches for a negative edge in every field, otherwise the RGB drive signals are blanked.
- Drive shutoff during flyback: this feature can be selected by software.
- Safety input pin: this input has two thresholds. Between zero and the lower threshold, normal functioning takes place. Between the lower and the higher threshold, the RGB signals are blanked. Above the higher threshold, the RGB signals are blanked and the horizontal drive is shut off. Both thresholds have a small hysteresis.
- The main oscillator and the horizontal drive circuitry are run from a separate (standby) power supply and are already active while the TV set is powering up.

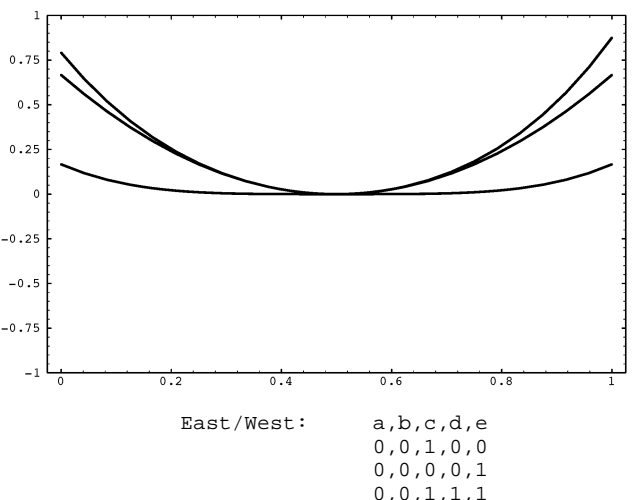
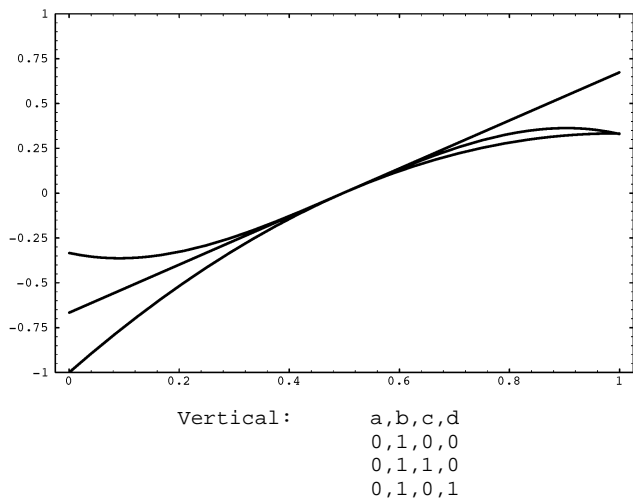

Fig. 2-30: Vertical and East/West deflection waveforms

2.12. Reset Function

Reset of most VDP 31xxB functions is performed by the $\overline{\text{RESET}}$ pin. When this pin becomes active, all internal registers and counters are lost. When the $\overline{\text{RESET}}$ pin is released, the internal reset is still active for 4 μs . After that time, the initialization of all required registers is performed by the internal Fast Processor. During this initialization procedure (see Fig. 2–31) it is not possible to access the VDP 31xxB via the serial interface (I²C). Access to other ICs via the serial bus is possible during that time.

The 5 MHz clock divider and the 1 MHz standby clock divider are not affected by reset. The clock source for the horizontal output generator is switched to the standby clock during reset.

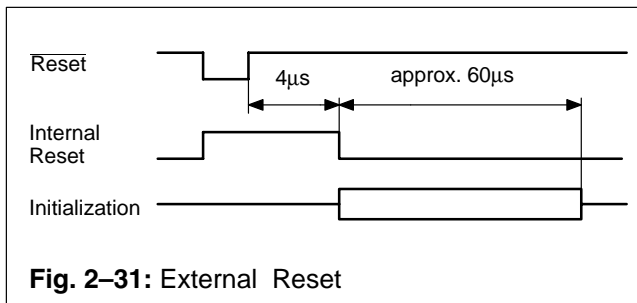

Fig. 2–31: External Reset

2.13. Standby and Power-On

In standby mode the whole signal processing of the VDP 31xxB is disabled and only some basic functions are working. The standby mode is realized by switching off the supplies for analog front-end (VSUPF), analog back-end (VSUPO) and digital circuitry (VSUPD). The standby supply (VSTBY) still has its nominal voltage.

To disable all the analog and digital functions, it is necessary to bring the analog and digital supplies below 0.5 V. Only this guarantees that all the normal functions are disabled and the standby current for analog and digital supply is at its minimum.

When switched off, the negative slope of the supply voltage VSUPD should not be larger than approximately 0.2 V/ μs (see Recommended Operating Conditions).

In the standby mode, all registers and counter values in the VDP 31xxB are lost, they will be re-initialized via the internal Fast Processor after analog and digital supplies are switched on again and the $\overline{\text{RESET}}$ pin is released.

In the standby mode the following functions are still available (see also 2.11.1.):

- 20.25 MHz crystal oscillator
- 5 MHz clock output (CLK5)
- horizontal drive output (HOUT)

The clock source for the horizontal output generator is switched to the standby clock which is derived from the 5 MHz clock. The duty cycle of HOUT is set to 50%. Protection modes with safety and horizontal flyback pins are not available.

The VDP 31xxB has clock and voltage supervision circuits to generate a stable HOUT signal during power-on and standby. The HOUT signal is disabled until a proper CLK5 signal (5 MHz clock) is detected. When released, the HOUT generator runs with the standby clock. Coupling the HOUT generator to the deflection PLL has to be done by CCU using the EHPLL bit. Fig. 2–32 shows the signals during power-on and standby.

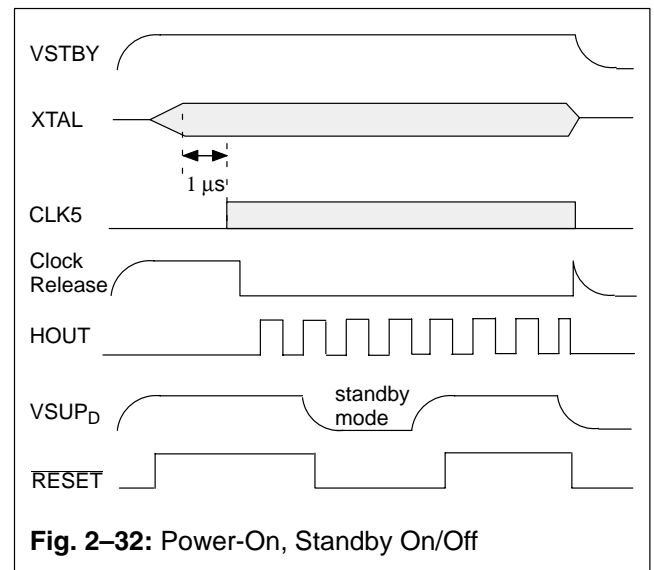

Fig. 2–32: Power-On, Standby On/Off

Switching the HOUT signal into standby mode can be done by the CCU via the EHPLL bit or by the internal voltage supervision. The voltage supervision activates a power-down signal when the supply for the digital circuits (VSUPD) goes below ~ 4.5 V for more than 50ns. This power down signal is extended by 50 μs after VSUPD is back again. The power-down signal switches the clock source for the HOUT generation to the standby clock and sets the duty cycle to 50%. This is exactly what the EHPLL bit does.

As the clocks from the deflection PLL and the standby clock are not in phase, the actual phase (High/Low) of the HOUT signal may be up to one PLL or standby clock (~ 1 μs) longer than a regular one when the clock source is changed.

3. Serial Interface

3.1. I²C-Bus Interface

Communication between the VDP and the external controller is done via I²C-bus. The VDP has two I²C-bus slave interfaces (for compatibility with VPC/DDP applications) – one in the front-end and one in the back-end. Both I²C-bus interfaces use I²C clock synchronization to slow down the interface if required. Both I²C-bus interfaces use one level of subaddress: the I²C-bus chip address is used to address the IC and a subaddress selects one of the internal registers. The I²C-bus chip addresses are given below:

| Chip Address | A6 | A5 | A4 | A3 | A2 | A1 | A0 | R/W |
|--------------|----|----|----|----|----|----|----|-----|
| front-end | 1 | 0 | 0 | 0 | 1 | 1 | 1 | 1/0 |
| back-end | 1 | 0 | 0 | 0 | 1 | 0 | 1 | 1/0 |

The registers of the VDP have 8 or 16-bit data size; 16-bit registers are accessed by reading/writing two 8-bit data words.

Figure 3–1 shows I²C-bus protocols for read and write operations of the interface; the read operation requires an extra start condition and repetition of the chip address with read command set.

3.2. Control and Status Registers

Table 3–1 gives definitions of the VDP control and status registers. The number of bits indicated for each register in the table is the number of bits implemented in hardware, i.e. a 9-bit register must always be accessed using two data bytes but the 7 MSB will be ‘don’t care’ on write operations and ‘0’ on read operations. Write registers that can be read back are indicated in Table 3–1.

Functions implemented by software in the on-chip control microprocessor (FP) are explained in Table 3–3.

A hardware reset initializes all control registers to 0. The automatic chip initialization loads a selected set of registers with the default values given in Table 3–1.

The register modes given in Table 3–1 are

- w: write only register
- w/r: write/read data register
- r: read data from VDP
- v: register is latched with vertical sync
- h: register is latched with horizontal sync

The mnemonics used in the Micronas VDP demo software are given in the last column.

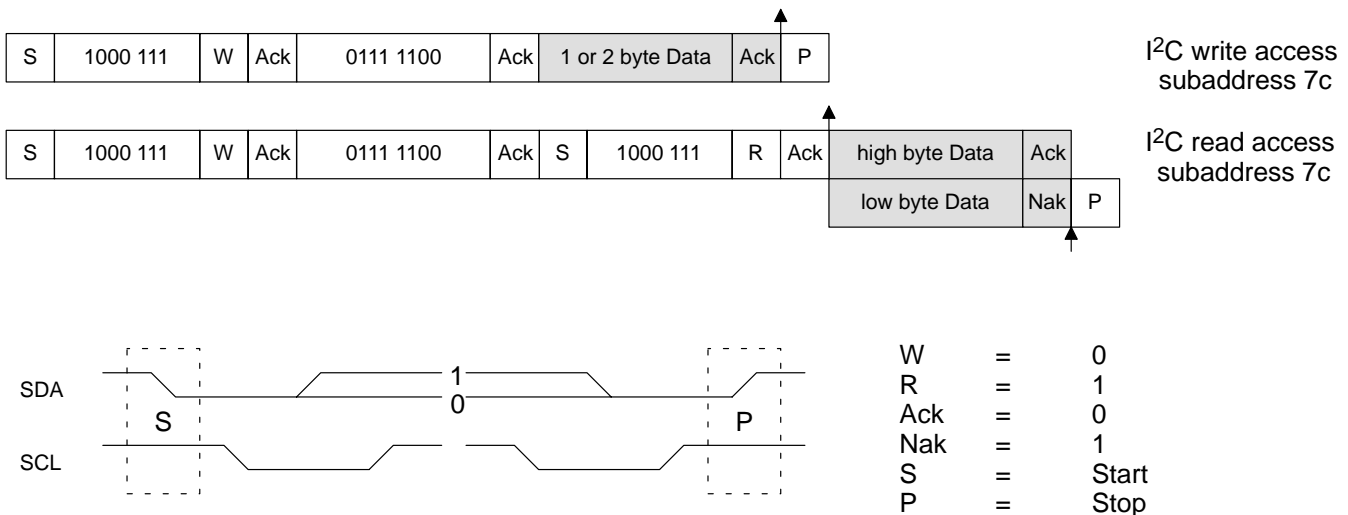

Fig. 3–1: I²C-bus protocols

Table 3–1: I²C control and status registers of front-end

| I ² C Sub address | Number of bits | Mode | Function | Default | Name |
|------------------------------|----------------|------|---|-----------------------|--|
| FP INTERFACE | | | | | |
| h'35 | 8 | r | FP status bit [0] write request bit [1] read request bit [2] busy | | FPSTA |
| h'36 | 16 | w | bit[8:0] 9-bit FP read address bit[11:9] reserved, set to zero | | FPRD |
| h'37 | 16 | w | bit[8:0] 9-bit FP write address bit[11:9] reserved, set to zero | | FPWR |
| h'38 | 16 | w/r | bit[11:0] FP data register, reading/writing to this register will autoincrement the FP read/write address. Only 16 bit of data are transferred per I ² C telegram. | | FPDAT |
| BLACK LINE DETECTOR | | | | | |
| h'12 | 16 | w/r | read only register, do not write to this register! after reading, LOWLIN and UPLIN are reset to 127 to start a new measurement bit[6:0] number of lower black lines bit[7] always 0 bit[14:8] number of upper black lines bit[15] 0/1 normal/black picture | | BLKLIN LOWLIN UPLIN BLKPIC |
| PIN CIRCUITS | | | | | |
| h'1F | 16 | w/r | INTLC & PORT pins: bit[2:0] 0..7 output strength for INTLC & PORT Pins (7 = tristate, 6 = weak ... 0 = strong) bit[3] 0 reserved (set to 0) bit[4] 0/1 pushpull/tristate for INTLC Pin bit[5] 0/1 synchronization/no synchronization with horizontal MSY for signal INTLC bit[15:6] reserved (set to 0) | 0 0 0 | TRPAD SNCSTR SNCDIS VASYSEL |
| h'20 | 8 | w/r | SYNC GENERATOR CONTROL: bit[6:0] 0 reserved (set to 0) bit[7] 0/1 positive/negative polarity for INTLC signal | 0 | SYNMODE INTLCINV |
| PRIORITY BUS | | | | | |
| h'24 | 8 | w/r | priority bus ID register and control bit [2:0] 0..7 priority ID, 0 highest bit [4:3] 0..3 pad driver strength, 0 (strong) to 3 (weak) bit [5] 0/1 reserved (set to 0) bit [6] 0/1 source for prio request: active video/clamp_to_1 bit [7] 0/1 disable/enable priority interface, if disabled frontend is disconnected from priority bus! | 0 0 0 0 0 | PRIOMODE PID PRIOSTR PIDSRC PIDE |

| I ² C Sub address | Number of bits | Mode | Function | Default | Name |
|------------------------------|----------------|------|---|----------------------------|--------------------------------------|
| SYNC GENERATOR | | | | | |
| h'21 | 16 | w/r | LINE LENGTH: bit[10:0] LINE LENGTH register LINE LENGTH has to be set to 1295 for correct adjustment of vertical signals. bit[15:11] reserved (set to 0) | 1295 | LINLEN |
| h'29 | 16 | w/r | AVO STOP: bit[10:0] reserved (set to 0) bit[11] 0/1 disable/enable test pattern generator bit[13:12] luma output mode: 00 Y = rampe (240 ... 17) 01 Y = 16 10 Y = 90 11 Y = 240 bit[14] 0/1 reserved (set to 0) bit[15] 0/1 chroma output: pseudo color bar/zero | 0 0 0 0 0 0 | AVSTOP COLBAREN LMODE CMODE |
| h'22 | 16 | w/r | NEWLINE: bit[10:0] NEWLINE register This register defines the readout start of the next line in respect to the value of the sync counter. Value of this register must be greater than 31 for correct operation. bit [15:11] reserved (set to 0) | 50 | NEWLIN |

Table 3–2: Backend I²C-control and status registers

| I ² C sub address | Number of bits | Mode | Function | Default | Name |
|------------------------------|----------------|------|---|-------------|-----------------------|
| PRIORITY BUS | | | | | |
| | | | priority mask register, if bit[x] is set to 1 then the function is active for the respective signal priority | | |
| h'75 | 9 | w v | bit [7:0] bit[x] 0/1: select contrast,brightness,matrix for main/side picture | 0 | PBCT |
| h'71 | 9 | w v | bit [7:0] bit[x] 0/1: select main (video)/external (via CLUT) RGB | 0 | PBERGB |
| h'7d | 9 | w v | bit [7:0] bit[x] 0/1: enable/disable black level expander | 0 | PBBLE |
| h'79 | 9 | w v | bit [7:0] bit[x] 0/1: disable/enable peaking transient suppression when signal is switched | 0 | PBPK |
| h'4b | 9 | w v | bit [7:0] bit[x] 0/1: disable/enable analog fast blank input | 0 | PBFB |
| h'47 | 9 | w v | bit [2:0] picture frame generator priority id bit [8] enable prio id for picture frame generator | 0 | PFGID PFGEN |
| LUMA CHANNEL | | | | | |
| h'61 | 9 | w v | bit [5:0] 0..63/32 main picture contrast | 32 | CTM |
| h'65 | 9 | w v | bit [5:0] 0..63/32 side picture contrast | 32 | CTS |
| h'51 | 9 | w v | bit [8:0] –256..255 main picture brightness | 0 | BRM |
| h'55 | 9 | w v | bit [8:0] –256..255 side picture brightness | 0 | BRS |
| h'59 | 9 | w v | black level expander: bit [3:0] 0..15 tilt coefficient bit [8:4] 0...31 amount | 8 12 | BTLT BAM |
| h'5d | 9 | w v | black level expander: bit [8:0] 0..511 disable expansion, threshold value | 200 | BTHR |
| h'69 | 9 | w v | luma peaking filter, the gain at high frequencies and small signal amplitudes is: $1 + (k1+k2)/8$ bit [3:0] 0..15 k1: peaking level undershoot bit [7:4] 0..15 k2: peaking level overshoot bit [8] 0/1 peaking value normal/inverted (peaking/softening) | 4 4 0 | PKUN PKOV PKINV |
| h'6d | 9 | w v | luma peaking filter, coring bit [4:0] 0..31 coring level bit [7:5] reserved bit [8] 0/1 peaking filter center frequency high/low | 3 0 | COR PFS |
| h'41 | 9 | w v | luma soft limiter, slope A and B bit [3:0] slope segment A bit [7:4] slope segment B | 0 0 | LSLSA LSLSB |
| h'45 | 9 | w v | bit [7:0] luma soft limiter absolute limit (unsigned) bit [8] 0/1 modulation off/on | 255 1 | LSLAL LSLM |
| h'49 | 9 | w v | bit [8:0] luma soft limiter segment B tilt point (unsigned) | 300 | LSLTB |
| h'4d | 9 | w v | bit [8:0] luma soft limiter segment A tilt point (unsigned) | 250 | LSLTA |

| I ² C sub address | Number of bits | Mode | Function | Default | Name |
|------------------------------|----------------|------|--|----------|--------------|
| h'4c | 9 | w v | digital OSD insertion contrast for R (amplitude range: 0 to 255) bit [3:0] 0..13 R amplitude = CLUTn · (DRCT + 4) 14,15 invalid | 8 | DRCT |
| | | | picture frame insertion contrast for R (ampl. range: 0 to 255) bit [7:4] 0..13 R amplitude = PFCR · (PFRCT + 4) 14,15 invalid | 8 | PFRCT |
| h'48 | 9 | w v | digital OSD insertion contrast for G (amplitude range: 0 to 255) bit [3:0] 0..13 G amplitude = CLUTn · (DGCT + 4) 14,15 invalid | 8 | DGCT |
| | | | picture frame insertion contrast for G (ampl. range: 0 to 255) bit [7:4] 0..13 G amplitude = PFCG · (PFGCT + 4) 14,15 invalid | 8 | PFGCT |
| h'44 | 9 | w v | digital OSD insertion contrast for B (amplitude range: 0 to 255) bit [3:0] 0..13 B amplitude = CLUTn · (DBCT + 4) 14,15 invalid | 8 | DBCT |
| | | | picture frame insertion contrast for B (ampl. range: 0 to 255) bit [7:4] 0..13 B amplitude = PFCB · (PFBCT + 4) 14,15 invalid | 8 | PFBCT |
| PICTURE FRAME GENERATOR | | | | | |
| h'4F | 9 | w v | bit [8:0] horizontal picture frame begin code 0 = picture frame generator horizontally disabled code 1FF = full frame | 0 | PFGHB |
| h'53 | 9 | w v | bit [8:0] horizontal picture frame end | 0 | PFGHE |
| h'63 | 9 | w v | bit [8:0] vertical picture frame begin code 0 = picture frame generator vertically disabled | 270 | PFGVB |
| h'6f | 9 | w v | bit [8:0] vertical picture frame end | 56 | PFGVE |
| | | | enable and priority – see under 'PRIORITY BUS' picture frame color – see under 'COLOR LOOK-UP TABLE' | | |
| SCAN VELOCITY MODULATION | | | | | |
| h'62 | 9 | w v | video mode coefficients bit [5:0] gain1 bit [8:6] differentiator delay 1 (0= filter off, 1...6= delay) | 60 4 | SVG1 SVD1 |
| h'5e | 9 | w v | text mode coefficients bit [5:0] gain 2 bit [8:6] differentiator delay 2 (0= filter off, 1...6= delay) | 60 4 | SVG2 SVD2 |
| h'5a | 9 | w v | limiter bit [6:0] limit value bit [8:5] not used, set to "0" | 100 0 | SVLIM |
| h'56 | 9 | w v | delay and coring bit [3:0] adjustable delay, in 1/2 display clock steps, (value 5 : delay of SVMOUT is the same as for RGBOUT | 7 | SVDEL |
| | | | bit [7:4] coring value bit [8] not used, set to "0" | 0 | SVCOR |

| I ² C sub address | Number of bits | Mode | Function | Default | Name |
|--|----------------|------|---|--------------|---|
| DISPLAY CONTROLS | | | | | |
| h'52 | 9 | w v | cutoff Red | 0 | CR |
| h'4e | 9 | w v | cutoff Green | 0 | CG |
| h'4a | 9 | w v | cutoff Blue | 0 | CB |
| TUBE AND PICTURE MEASUREMENT | | | | | |
| h'7b | 9 | w v | picture measurement start line bit [8:0] (TML+9)..511 first line of picture measurement | 23 | PMST |
| h'6b | 9 | w v | picture measurement stop line bit [8:0] (PMST+1)..511 last line of picture measurement | 308 | PMSO |
| h'7f | 9 | w v | tube measurement line bit [8:0] 0..511 start line for tube measurement | 15 | TML |
| h'25 | 8 | w/r | tube and picture measurement control bit [0] 0/1 disable/enable tube measurement bit [1] 0/1 80/40 kHz bandwidth for picture measurement bit [2] 0/1 disable/enable picture measurement (writing a '1' starts one measurement cycle) bit [3] 0/1 large/small picture measurement window, will be disabled from bit[3] in address h'32 bit [4] 0/1 measure / offset check for adc bit [7:5] reserved | 0 | PMC TMEN PMBW PMEN PMWIN OFSEN |
| h'13 | 16 | w/r | white drive measurement control bit [9:0] 0..1023 RGB values for white drive beam current measurement bit [10] reserved bit [11] 0/1 RGB values for white drive beam current measurement disabled/enabled | 512 0 | WDRV EWDM |
| h'18 h'19 h'1a h'1d h'1c h'1b | 8 | r | measurement result registers minimum in active picture maximum in active picture white drive cutoff/leakage red cutoff/leakage green cutoff/leakage blue, read pulse starts tube measurement | - | MRMIN MRMAX MRWDR MRCR MRCG MRCB |
| h'1e | 8 | r | measurement adc status and fast blank input status measurement status register bit [0] 0/1 tube measurement active / complete bit [2:1] white drive measurement cycle 00 red 01 green 10 blue 11 reserved bit [3] 0/1 picture measurement active / complete bit [4] 0/1 fast blank input low / high (static) bit [5] 1 fast blank input negative transition since last read (bit reset at read) bit [7:6] reserved | - | PMS |

| I ² C sub address | Number of bits | Mode | Function | Default | Name |
|------------------------------|----------------|------|--|---|--|
| TIMING | | | | | |
| h'67 | 9 | w v | vertical blanking start bit [8:0] 0..511 first line of vertical blanking | 305 | VBST |
| h'77 | 9 | w v | vertical blanking stop bit [8:0] 0..511 last line of vertical blanking | 25 | VBSO |
| h'73 | 9 | w v | start of Black Level Expander measurement bit [8:0] 0..511 first line of measurement, stop with first line of vertical blanking | 30 | AVST |
| h'5f | 9 | w v | bit [8:0] free running field period = (value + 4) lines | 0 | STIMP |
| HORIZONTAL DEFLECTION | | | | | |
| h'7a | 9 | w v | adjustable delay of PLL2, clamping, and blanking (relative to front sync) adjust clamping pulse for analog RGB input bit [8:0] -256..+255 ± 8 μs | -141 | POFS2 |
| h'76 | 9 | w v | adjustable delay of flyback, main sync, csync and analog RGB (relative to PLL2) adjust horizontal drive or csync bit [8:0] -256..+255 ± 8 μs | 0 | POFS3 |
| h'7e | 9 | w v | adjustable delay of main sync (relative to flyback) adjust horizontal position for digital picture bit [8:0] 20 steps = 1 μs | 120 | HPOS |
| h'5b | 9 | w/r | start of horizontal blanking bit [8:0] 0..511 | 1 | HBST |
| h'57 | 9 | w/r | end of horizontal blanking bit [8:0] 0..511 | 48 | HBSO |
| h'6a | 9 | w v | PLL2/3 filter coefficients, 1of5 bit code (n = set bit number) bit [5:0] proportional coefficient PLL3, 2 ⁻ⁿ⁻¹ | 2 | PKP3 |
| h'6e | 9 | w v | bit [5:0] proportional coefficient PLL2, 2 ⁻ⁿ⁻¹ | 1 | PKP2 |
| h'72 | 9 | w v | bit [5:0] integral coefficient PLL2, 2 ⁻ⁿ⁻⁵ | 2 | PKI2 |
| h'15 | 16 | w/r | horizontal drive and vertical signal control register bit [5:0] 0..63 horizontal drive pulse duration in μs (internally limited to 4..61) bit [6] 0/1 disable/enable horizontal PLL2 and PLL3 bit [7] 0/1 1: disable horizontal drive pulse during flyback bit [8] 0/1 reserved, set to '0' bit [9] 0/1 enable/disable ultra black blanking bit [10] 0/1 0: all outputs blanked 1: normal mode bit [11] 0/1 enable/disable clamping for analog RGB input bit [12] 0/1 disable/enable vertical free running mode (FIELD is set to field2, no interlace) bit [13] 0/1 enable/disable vertical protection bit [14] 0/1 internal/external (under VPC control) start of vertical and E/W signal bit [15] 0/1 disable/enable phase shift of display clock | 32 0 0 0 1 0 0 0 0 1 | HDRV EHPLL EFLB DUBL EBL DCRGB SELFT DVPR XDEFL DISKA |

| I ² C sub address | Number of bits | Mode | Function | Default | Name |
|------------------------------|----------------|------|--|---------|---|
| OUTPUT PINS | | | | | |
| h'10 | 8 | w/r | output pin configuration bit [2:0] pin driver strength, MSY and CSY 7 = tristate 6 = minimum strength 0 = maximum strength bit [4:3] reserved (set to 0) bit [5] 0/1 disable/enable internal resistor for vertical and East/West drive output bit [7:6] function of CSY pin : 00 composite sync signal output 01 25 Hz output (field1/field2 signal) 10 no interlace (field 2), output = 0 11 1 MHz horizontal drive clock | 0 | PSTSY VEWXR CSYM |
| MISCELLANEOUS | | | | | |
| h'32 | 8 | w/r | fast blank interface mode bit [0] 0 internal fast blank 1 from FBLIN1 pin 1 force internal fast blank 1 signal to high bit [1] 0/1 internal fast blank active high/low bit [2] 0/1 disable/enable clamping reference for RGB outputs bit [3] 1 full line MADC measurement window, disables bit [3] in address h'25 bit [4] 0/1 horizontal flyback input active high/low bit [6:5] reserved (set to 0) bit [7] 0 internal fast blank 1 from FBLIN1 pin 1 force internal fast blank 1 signal to low | 0 | FBMOD FBFOH1 FBPOL CLMPR FLMW FLPOL FBFOL1 |
| h'31 | 8 | w/r | fast blank interface mode 2 bit [0] 0 internal fast blank 2 from FBLIN2 pin 1 force internal fast blank 2 signal to high bit [1] 0 internal fast blank 2 from FBLIN2 pin 1 force internal fast blank 2 signal to low bit [2] fast blank input priority 0 FBLIN1 > FBLIN2 1 FBLIN1 < FBLIN2 bit [3] fast blank monitor input select 0 monitor connected to FBLIN1 pin 1 monitor connected to FBLIN2 pin bit [4] half contrast switch enable 0 PORT0 enable / HCS disable 1 PORT0 disable / HCS enable bit [5] half contrast from HCS pin 0 force half contrast signal to high 1 force half contrast signal to high bit [6] half contrast active high/low at HCS pin bit [7] reserved (set to 0) | 0 | FBMOD2 FBFOH2 FBFOL2 FBPRIO FBMON HCSSEN HCSFOH HCSPOL |
| h'34 | 16 | w/r | IO Port bit [6:0] data to/from PORT[6:0] bit [7] front sync output at PORT1 0 PORT1 input/output enable 1 FSY output enable bit [14:8] port direction 0 switch PORT[bit-8] to input 1 switch PORT[bit-8] to output bit [15] port enable 0 COLOR[4:0] enable / PORT[6:2] disable 1 COLOR[4:0] disable / PORT[6:2] enable | 0 | IOPORT IODATA FSYOEN IODIR IOEN |

Table 3–3: Control Registers of the Fast Processor for control of front-end functions

– default values are initialized at reset

| FP Sub-address | Function | Default | Name | | | | | | | | | | | | | | | | | | | | | | | | |
|---------------------------|--|----------|---------------------|----------|---|----------------|----------|---|---------------|-------|---|----------------|----------|---|---------------|----------|---|---------------|----------|---|----------------|----------|---|-------------------|----------|---|---|
| Standard Selection | | | | | | | | | | | | | | | | | | | | | | | | | | | |
| h'20 | <p>Standard select:</p> <p>bit[2:0] standard</p> <table style="margin-left: 20px;"> <tr><td>0</td><td>PAL B,G,H,I (50 Hz)</td><td>4.433618</td></tr> <tr><td>1</td><td>NTSC M (60 Hz)</td><td>3.579545</td></tr> <tr><td>2</td><td>SECAM (50 Hz)</td><td>4.286</td></tr> <tr><td>3</td><td>NTSC44 (60 Hz)</td><td>4.433618</td></tr> <tr><td>4</td><td>PAL M (60 Hz)</td><td>3.575611</td></tr> <tr><td>5</td><td>PAL N (50 Hz)</td><td>3.582056</td></tr> <tr><td>6</td><td>PAL 60 (60 Hz)</td><td>4.433618</td></tr> <tr><td>7</td><td>NTSC COMB (60 Hz)</td><td>3.579545</td></tr> </table> <p>bit[3] 0/1 standard modifier PAL modified to simple PAL NTSC modified to compensated NTSC SECAM modified to monochrome 625 NTSCC modified to monochrome 525</p> <p>bit[4] reserved (set to 0)</p> <p>bit[5] 0/1 2-H comb filter off/on</p> <p>bit[6] 0/1 S-VHS mode off/on</p> <p>Option bits allow to suppress parts of the initialization, this can be used for color standard search:</p> <p>bit[7] no hpll setup</p> <p>bit[8] no vertical setup</p> <p>bit[9] no acc setup</p> <p>bit[10] 2-H comb filter set-up only</p> <p>bit[11] status bit, normally write 0. After the FP has switched to a new standard, this bit is set to 1 to indicate operation complete. Standard is automatically initialized when the insel register is written.</p> | 0 | PAL B,G,H,I (50 Hz) | 4.433618 | 1 | NTSC M (60 Hz) | 3.579545 | 2 | SECAM (50 Hz) | 4.286 | 3 | NTSC44 (60 Hz) | 4.433618 | 4 | PAL M (60 Hz) | 3.575611 | 5 | PAL N (50 Hz) | 3.582056 | 6 | PAL 60 (60 Hz) | 4.433618 | 7 | NTSC COMB (60 Hz) | 3.579545 | 0 | <p>sdt</p> <p>pal</p> <p>ntsc</p> <p>secam</p> <p>ntsc44</p> <p>palm</p> <p>paln</p> <p>pal60</p> <p>ntsc</p> <p>sdtmod</p> <p>comb</p> <p>svhs</p> <p>sdtopt</p> |
| 0 | PAL B,G,H,I (50 Hz) | 4.433618 | | | | | | | | | | | | | | | | | | | | | | | | | |
| 1 | NTSC M (60 Hz) | 3.579545 | | | | | | | | | | | | | | | | | | | | | | | | | |
| 2 | SECAM (50 Hz) | 4.286 | | | | | | | | | | | | | | | | | | | | | | | | | |
| 3 | NTSC44 (60 Hz) | 4.433618 | | | | | | | | | | | | | | | | | | | | | | | | | |
| 4 | PAL M (60 Hz) | 3.575611 | | | | | | | | | | | | | | | | | | | | | | | | | |
| 5 | PAL N (50 Hz) | 3.582056 | | | | | | | | | | | | | | | | | | | | | | | | | |
| 6 | PAL 60 (60 Hz) | 4.433618 | | | | | | | | | | | | | | | | | | | | | | | | | |
| 7 | NTSC COMB (60 Hz) | 3.579545 | | | | | | | | | | | | | | | | | | | | | | | | | |
| h'22 | <p>picture start position, this register sets the start point of active video, this can be used e.g. for panning. The setting is updated when 'sdt' register is updated.</p> | 0 | sfif | | | | | | | | | | | | | | | | | | | | | | | | |
| h'23 | <p>luma/chroma delay adjust. The setting is updated when 'sdt' register is updated.</p> <p>bit[5:0] reserved, set to zero</p> <p>bit[11:6] luma delay in clocks, allowed range is +1 ... -7</p> | 0 | ldly | | | | | | | | | | | | | | | | | | | | | | | | |

| FP Sub-address | Function | Default | Name |
|---------------------------|---|---------|--------|
| Standard Selection | | | |
| h'21 | Input select: writing to this register will also initialize the standard | | insel |
| bit[1:0] | luma selector | 00 | vis |
| | 00 VIN3 | | |
| | 01 VIN2 | | |
| | 10 VIN1 | | |
| | 11 VIN4 | | |
| bit[2] | chroma selector | 1 | cis |
| | 0/1 VIN1/CIN | | |
| bit[4:3] | IF compensation | 00 | ifc |
| | 00 off | | |
| | 01 6 dB/Okt | | |
| | 10 12 dB/Okt | | |
| | 11 10 dB/MHz only for SECAM | | |
| bit[6:5] | chroma bandwidth selector | 01 | cbw |
| | 00 narrow | | |
| | 01 normal | | |
| | 10 broad | | |
| | 11 wide | | |
| bit[7] | 0/1 adaptive/fixed SECAM notch filter | | fntch |
| bit[8] | 0/1 enable luma lowpass filter | | lowp |
| bit[10:9] | hpll speed | | hpllmd |
| | 00 no change | | |
| | 01 terrestrial | | |
| | 10 vcr | | |
| | 11 mixed | | |
| bit[11] | status bit, write 0, this bit is set to 1 to indicate operation complete. | | |
| Comb Filter | | | |
| h'27 | comb filter control register | | cmb_uc |
| bit[0] | 0 comb coefficients are calculated for luma/chroma | 0 | cc |
| | 1 comb coefficients for luma are used for luma and chroma | | |
| bit[1] | 0 luma comb strength depends on signal amplitude | 0 | daa |
| | 1 luma comb strength is independent of amplitude | | |
| bit[2] | 0 reduced comb booster | 1 | kb |
| | 1 max comb booster | | |
| bit[4:3] | 0..3 comb strength for chroma signal | 3 | kc |
| bit[6:5] | 0..3 comb strength for luma signal | 2 | ky |
| bit[11:7] | 0..31 overall limitation of the calculated comb coefficients | 0 | clim |
| | 0 no limitation | | |
| | 31 max limitation (1/2) | | |
| Color Processing | | | |
| h'39 | amplitude killer level (0:killer disabled) | 25 | kilvl |
| h'3a | amplitude killer hysteresis | 5 | kilhy |
| h'dc | NTSC tint angle, $\pm 512 = \pm \pi/4$ | 0 | tint |

| FP Sub-address | Function | Default | Name |
|---------------------------|--|------------|------------------|
| DVCO | | | |
| h'f8 | crystal oscillator center frequency adjust, -2048 ... 2047 | -720 | dvco |
| h'f9 | crystal oscillator center frequency adjustment value for line lock mode, true adjust value is DVCO – ADJUST. For factory crystal alignment, using standard video signal: set DVCO = 0, set lock mode, read crystal offset from ADJUST register and use negative value for initial center frequency adjustment via DVCO. | read only | adjust |
| h'f7 | crystal oscillator line-locked mode, lock command/status write: 100 enable lock 0 disable lock read: 0 unlocked >2047 locked | 0 | xlck |
| FP Status Register | | | |
| h'12 | general purpose control bits bit[2:0] reserved, do not change bit[3] vertical standard force bit[8:4] reserved, do not change bit[9] disable flywheel interlace bit[11:10] reserved, do not change to enable vertical free run mode set vfrc to 1 and dflw to 0 | 0 1 | vfrc dflw |
| h'13 | standard recognition status bit[0] 1 vertical lock bit[1] 1 horizontally locked bit[2] 1 no signal detected bit[3] 1 color amplitude killer active bit[4] 1 disable amplitude killer bit[5] 1 color ident killer active bit[6] 1 disable ident killer bit[7] 1 interlace detected bit[8] 1 no vertical sync detection bit[9] 1 spurious vertical sync detection bit[11:10] reserved | – | asr |
| h'cb | number of lines per field, P/S: 312, N: 262 | read only | nlpf |
| h'15 | vertical field counter, incremented per field | | vcnt |
| h'74 | measured sync amplitude value, nominal: 768 (PAL), 732 (NTSC) | read only | sampl |
| h'31 | measured burst amplitude | read only | bampl |
| h'f0 | firmware version number bit[7:0] internal revision number bit[11:8] firmware release | read only | sw_version |
| h'f1 | hardware version number bit[7:0] internal hardware revision number bit[11:8] hardware id 0000 = VDP 3120B 1000 = VDP 3116B 0100 = VDP 3112B 1100 = VDP 3108B 1110 = VDP 3104B | read only | hw_version |

| FP Sub-address | Function | Default | Name |
|--------------------------------|--|---------|----------------|
| Scaler Control Register | | | |
| h'40 | scaler mode register bit[1:0] scaler mode 0 linear scaling mode 1 nonlinear scaling mode, 'panorama' 2 nonlinear scaling mode, 'waterglass' 3 reserved bit[10:2] reserved, set to 0 bit[11] scaler update 0 start scaler update command, when the registers are updated the bit is set to 1 | 0 | scmode pano |
| h'41 | luma offset register bit[6:0] luma offset 0..127 ITU-R output format: 57 CVBS output format: 4 this register is updated when the scaler mode register is written | 57 | yoffs |
| h'42 | active video length for 1-h FIFO bit[11:0] length in pixels this register is updated when the scaler mode register is written | 1080 | fflim |
| h'43 | scaler1 coefficient, this scaler is compressing the signal. For compression by a factor c the value $c*1024$ is required. bit[11:0] allowed values from 1024..4095 this register is updated when the scaler mode register is written | 1024 | scinc1 |
| h'44 | scaler2 coefficient, this scaler is expanding the signal. For expansion by a factor c the value $1/c*1024$ is required. bit[11:0] allowed values from 256..1024 this register is updated when the scaler mode register is written | 1024 | scinc2 |
| h'45 | scaler1/2 nonlinear scaling coefficient this register is updated when the scaler mode register is written | 0 | scinc |
| h'47 – h'4b | scaler1 window controls, see table 5 12-bit registers for control of the nonlinear scaling this register is updated when the scaler mode register is written | 0 | scw1_0 – 4 |
| h'4c – h'50 | scaler2 window controls see table 5 12-bit registers for control of the nonlinear scaling this register is updated when the scaler mode register is written | 0 | scw2_0 – 4 |

3.2.1. Scaler Adjustment

In case of linear scaling, most of the scaler registers need not be set. Only the scaler mode, active video length, and the fixed scaler increments (scinc1/scinc2) must be written.

The adjustment of the scaler for nonlinear scaling modes should use the parameters given in Table 3–4.

Table 3–4: Set-up values for nonlinear scaler modes

| Register | Scaler Modes | | | |
|----------|----------------------------|------|--------------------------|------|
| | 'waterglass' border 35% | | 'panorama' border 30% | |
| | center compression | | | |
| | 3/4 | 5/6 | 4/3 | 6/5 |
| scinc1 | 1643 | 1427 | 1024 | 1024 |
| scinc2 | 1024 | 1024 | 376 | 611 |
| scinc | 90 | 56 | 85 | 56 |
| fflim | 945 | 985 | 921 | 983 |
| scw1 – 0 | 110 | 115 | 83 | 94 |
| scw1 – 1 | 156 | 166 | 147 | 153 |
| scw1 – 2 | 317 | 327 | 314 | 339 |
| scw1 – 3 | 363 | 378 | 378 | 398 |
| scw1 – 4 | 473 | 493 | 461 | 492 |
| scw2 – 0 | 110 | 115 | 122 | 118 |
| scw2 – 1 | 156 | 166 | 186 | 177 |
| scw2 – 2 | 384 | 374 | 354 | 363 |
| scw2 – 3 | 430 | 425 | 418 | 422 |
| scw2 – 4 | 540 | 540 | 540 | 540 |

Table 3–5: Control Registers of the Fast Processor for control of back-end functions

– default values are initialized at reset

| FP Sub-address | Function | Default | Name |
|---|--|---------|-------------------|
| FP Display Control Register | | | |
| h'130 | White Drive Red (0...1023) | 700 | WDR ¹⁾ |
| h'131 | White Drive Green (0...1023) | 700 | WDG ¹⁾ |
| h'132 | White Drive Blue (0...1023) | 700 | WDB ¹⁾ |
| h'139 | Internal Brightness, Picture (0...511), the center value is 256, the range allows for both increase and reduction of brightness. | 256 | IBR |
| h'13c | Internal Brightness, Measurement (0...511), the center value is 256, the brightness for measurement can be set to measure at higher cutoff current. The measurement brightness is independent of the drive values. | 256 | IBRM |
| h'13a | Analog Brightness for external RGB (0...511), the center value is 256, the range allows for both increase and reduction of brightness. | 256 | ABR |
| h'13b | Analog Contrast for external RGB (0...511) | 350 | ACT |
| ¹⁾ The white drive values will become active only after writing the blue value WDB, latching of new values is indicated by setting the MSB of WDB. | | | |
| FP Display Control Register, BCL | | | |
| h'144 | BCL threshold current, 0...2047 (max ADC output ~1152) | 1000 | BCLTHR |
| h'142 | BCL time constant 0...15 →13 ... 1700 msec | 15 | BCLTM |
| h'143 | BCL loop gain. 0..15 | 0 | BCLG |
| h'145 | BCL minimum contrast 0...1023 | 307 | BCLMIN |
| h'105 | Test register for BCL/EHT comp. function, register value: 0 normal operation 1 stop ADC offset compensation x>1 use x in place of input from Measurement ADC | 0 | BCLTST |
| FP Display Control Register, Deflection | | | |
| h'103 | interlace offset, –2048..2047 This value is added to the SAWTOOTH output during one field. | 0 | INTLC |
| h'102 | discharge sample count for deflection retrace, SAWTOOTH DAC output impedance is reduced for DSCC lines after vertical retrace. | 7 | DSCC |
| h'11f | vertical discharge value, SAWTOOTH output value during discharge operation, typically same as A0 init value for sawtooth. | –1365 | DSCV |
| h'10b | EHT (electronic high tension) compensation coefficient, 0...511 | 0 | EHT |
| h'10a | EHT time constant. 0..15 → 3.2..410 msec | 15 | EHTTM |

Control Registers, continued

| FP Sub-address | Function | Default | Name |
|--|---|---------|------|
| FP Display Control Register, Vertical Sawtooth | | | |
| h'110 | DC offset of SAWTOOTH output This offset is independent of EHT compensation. | 0 | OFS |
| h'11b | accu0 init value | -1365 | A0 |
| h'11c | accu1 init value | 900 | A1 |
| h'11d | accu2 init value | 0 | A2 |
| h'11e | accu3 init value | 0 | A3 |
| FP Display Control Register, East-West Parabola | | | |
| h'12b | accu0 init value | -1121 | A0 |
| h'12c | accu1 init value | 219 | A1 |
| h'12d | accu2 init value | 479 | A2 |
| h'12e | accu3 init value | -1416 | A3 |
| h'12f | accu4 init value | 1052 | A4 |

3.2.2. Calculation of Vertical and East-West Deflection Coefficients

In Table 3–6 the formula for the calculation of the deflection initialization parameters from the polynomial coefficients a,b,c,d,e is given for the vertical and East-West deflection. Let the polynomial be

$$P : a + b(x - 0.5) + c(x - 0.5)^2 + d(x - 0.5)^3 + e(x - 0.5)^4$$

The initialization values for the accumulators a0..a3 for vertical deflection and a0..a4 for East-West deflection are 12-bit values. The coefficients that should be used to calculate the initialization values for different field frequencies are given below, the values must be scaled by 128, i.e. the value for a0 of the 50 Hz vertical deflection is

$$a0 = (a * 128 - b * 1365.3 + c * 682.7 - d * 682.7)/128$$

Table 3–6: Tables for the Calculation of Initialization values for Vertical Sawtooth and East-West Parabola

| Vertical Deflection 50 Hz | | | | |
|---------------------------|-----|---------|---------|---------|
| | a | b | c | d |
| a0 | 128 | -1365.3 | +682.7 | -682.7 |
| a1 | | 899.6 | -904.3 | +1363.4 |
| a2 | | | 296.4 | 898.4 |
| a3 | | | | 585.9 |
| Vertical Deflection 60 Hz | | | | |
| | a | b | c | d |
| a0 | 128 | -1365.3 | +682.7 | -682.7 |
| a1 | | 1083.5 | -1090.2 | +1645.5 |
| a2 | | | 429.9 | -1305.8 |
| a3 | | | | 1023.5 |

| East-West Deflection 50 Hz | | | | | |
|----------------------------|-----|--------|---------|--------|---------|
| | a | b | c | d | e |
| a0 | 128 | -341.3 | 1365.3 | -85.3 | 341.3 |
| a1 | | 111.9 | -899.6 | 84.8 | -454.5 |
| a2 | | | 586.8 | -111.1 | 898.3 |
| a3 | | | | 72.1 | -1171.7 |
| a4 | | | | | 756.5 |
| East-West Deflection 60 Hz | | | | | |
| | a | b | c | d | e |
| a0 | 128 | -341.3 | 1365.3 | -85.3 | 341.3 |
| a1 | | 134.6 | -1083.5 | 102.2 | -548.4 |
| a2 | | | 849.3 | -161.2 | 1305.5 |
| a3 | | | | 125.6 | -2046.6 |
| a4 | | | | | 1584.8 |

4. Specifications

4.1. Outline Dimensions

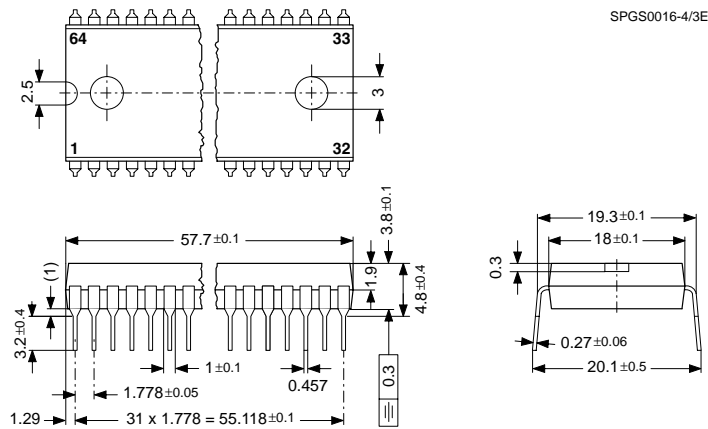

Fig. 4-1:
 64-Pin Plastic Shrink Dual-Inline Package
(PSDIP64)
 Weight approximately 9.0 g
 Dimensions in mm

4.2. Pin Connections and Short Descriptions

NC = not connected; leave vacant
 LV = if not used, leave vacant
 X = obligatory; connect as described in circuit diagram

| Pin No. | Pin Name | Type | Connection (if not used) | Short Description |
|---------|--------------|--------|--------------------------|--|
| 1 | TEST | IN | GND _{DF} | Test Pin, reserved for Test |
| 2 | RESQ | IN | X | Reset Input, Active Low |
| 3 | SCL | IN/OUT | X | I ² C Bus Clock |
| 4 | SDA | IN/OUT | X | I ² C Bus Data |
| 5 | DSGND | | X | Digital Shield GND _D |
| 6 | PORT0 HCS | IN/OUT | LV | IO Port Expander 0 / Half Contrast Switch |
| 7 | PORT1 FSY | IN/OUT | LV | IO Port Expander 1 / Front Sync Output |
| 8 | CSY | OUT | LV | Composite Sync Output |
| 9 | MSY | OUT | LV | Main Sync Output |
| 10 | INTLC | OUT | LV | Interlace Control Output |
| 11 | VPROT | IN | GND _O | Vertical Protection Input |
| 12 | SAFETY | IN | GND _O | Safety Input |
| 13 | HFLB | IN | HOUT | Horizontal Flyback Input |

| Pin No. | Pin Name | Type | Connection (if not used) | Short Description |
|---------|-------------------|--------|-----------------------------|---|
| 14 | GND _{DF} | | X | Ground, Digital Circuitry Front-end |
| 15 | VSUP _D | | X | Supply Voltage, Digital Circuitry |
| 16 | GND _{DO} | | X | Ground, Digital Circuitry Back-end |
| 17 | PR0 | IN/OUT | LV | Picture Bus Priority Control (LSB) |
| 18 | PR1 | IN/OUT | LV | Picture Bus Priority Control |
| 19 | PR2 | IN/OUT | LV | Picture Bus Priority Control (MSB) |
| 20 | COLOR4 PORT2 | IN/OUT | GND _{DF} | Picture Bus Color Address 4 / IO Port Expander 2 |
| 21 | COLOR3 PORT3 | IN/OUT | GND _{DF} | Picture Bus Color Address 3 / IO Port Expander 3 |
| 22 | COLOR2 PORT4 | IN/OUT | GND _{DF} | Picture Bus Color Address 2 / IO Port Expander 4 |
| 23 | COLOR1 PORT5 | IN/OUT | GND _{DF} | Picture Bus Color Address 1 / IO Port Expander 5 |
| 24 | COLOR0 PORT6 | IN/OUT | GND _{DF} | Picture Bus Color Address 0 / IO Port Expander 6 |
| 25 | DSGND | | X | Digital Shield GND _D |
| 26 | RSW2 | OUT | GND _O | Range Switch2 for Measurement ADC |
| 27 | RSW1 | OUT | GND _O | Range Switch1 for Measurement ADC |
| 28 | SENSE | IN | GND _O | Sense ADC Input |
| 29 | GND _M | | X | Ground, MADC Input |
| 30 | GND _V | OUT | LV | Ground, Vertical Outputs |
| 31 | VERT | OUT | LV | Vertical Sawtooth Output |
| 32 | EW | OUT | LV | Vertical Parabola Output |
| 33 | XREF | IN | X | Reference Input for RGB DACs |
| 34 | SVMOUT | OUT | VSUP _O | Scan Velocity Modulation Output |
| 35 | GND _O | | X | Ground, Analog Back-end |
| 36 | VSUP _O | | X | Supply Voltage, Analog Back-end |
| 37 | ROUT | OUT | VSUP _O | Analog Red Output |
| 38 | GOUT | OUT | VSUP _O | Analog Green Output |
| 39 | BOUT | OUT | VSUP _O | Analog Blue Output |
| 40 | VRD | IN | X | DAC Reference |
| 41 | RIN | IN | GND _O | Analog Red Input |
| 42 | GIN | IN | GND _O | Analog Green Input |

| Pin No. | Pin Name | Type | Connection (if not used) | Short Description |
|---------|-------------------|------|--------------------------|----------------------------------|
| 43 | BIN | IN | GND _O | Analog Blue Input |
| 44 | FBLIN | IN | GND _O | Fast Blank Input |
| 45 | RIN2 | IN | GND _O | Analog Red Input 2 |
| 46 | GIN2 | IN | GND _O | Analog Green Input 2 |
| 47 | BIN2 | IN | GND _O | Analog Blue Input 2 |
| 48 | FBLIN2 | IN | GND _O | Fast Blank Input 2 |
| 49 | CLK20 | OUT | LV | 20 MHz System Clock Output |
| 50 | HOUT | OUT | X | Horizontal Drive Output |
| 51 | XTAL1 | IN | X | Analog Crystal Input |
| 52 | XTAL2 | OUT | X | Analog Crystal Output |
| 53 | VSTBY | | X | Standby Supply Voltage |
| 54 | CLK5 | OUT | LV | 5 MHz Clock Output |
| 55 | GND _F | | X | Ground, Analog Front-end |
| 56 | ISGND | IN | GND _F | Signal Ground for Analog Input |
| 57 | VRT | IN | X | Reference Voltage Top, Video ADC |
| 58 | VSUP _F | | X | Supply Voltage, Analog Front-end |
| 59 | VOUT | OUT | LV | Analog Video Output |
| 60 | CIN | IN | VRT | Analog Chroma Input |
| 61 | VIN1 | IN | VRT | Analog Video 1 Input |
| 62 | VIN2 | IN | VRT | Analog Video 2 Input |
| 63 | VIN3 | IN | VRT | Analog Video 3 Input |
| 64 | VIN4 | IN | VRT | Analog Video 4 Input |

4.3. Pin Descriptions

Pin 1 – Test Input, **TEST** (Fig. 4–3)

This pin enables factory test modes. For normal operation it must be connected to ground.

Pin 2 – Reset Input, **RESQ** (Fig. 4–3)

A low level on this pin resets the VDP 31xxB.

Pin 3 – I²C Bus Clock, **SCL** (Fig. 4–12)

This pin connects to the I²C bus clock line.

Pin 4 – I²C Bus Data, **SDA** (Fig. 4–12)

This pin connects to the I²C bus data line.

Pin 5 – Ground (Digital Shield), **DSGND**

Pin 6, 7, 20–24 – IO Port Expander, **PORT[6:0]** (Fig. 4–13)

These pins provide an I²C programmable I/O port, which can be used to read and write slow external signals.

Pin 6 – Half Contrast Switch Input, **HCS** (Fig. 4–16)
Via this input pin the output level of the analog RGB output pins can be reduced by 3dB.

Pin 7 – Front Sync Output, **FSY** (Fig. 4–13)
This pin supplies the front sync information

Pin 8 – Composite Sync Output, **CSY** (Fig. 4–13)
This output supplies a standard composite sync signal that is compatible to the analog RGB output signals.

Pin 9 – Main Sync Output, **MSY** (Fig. 4–13)
This pin supplies the main sync information.

Pin 10 – Interlace Output, **INTLC** (Fig. 4–13)
This pin supplies the interlace information, 0 indicates first field, 1 indicates second field.

Pin 11 – Vertical Protection Input, **VPROT** (Fig. 4–14)
The vertical protection circuitry prevents the picture tube from burn-in in the event of a malfunction of the vertical deflection stage. During vertical blanking, a signal level of 2.5V is sensed. If a negative edge cannot be detected, the RGB output signals are blanked.

Pin 12 – Safety Input, **SAFETY** (Fig. 4–14)
This is a three-level input. Low level means normal function. At the medium level RGB signals are blanked and at high level RGB signals are blanked and horizontal drive is shut off.

Pin 13 – Horizontal Flyback Input, **HFLB** (Fig. 4–14)
Via this pin the horizontal flyback pulse is supplied to the VDP 31xxB.

Pin 14 – Ground (Digital Circuitry Front-end), **GND_{DF}**

Pin 15 – Supply Voltage (Digital Circuitry), **VSUP_D**

Pin 16 – Ground (Digital Circuitry Back-end), **GND_{DO}**

Pin 17, 18, 19 – Picture Bus Priority, **PR[2:0]** (Fig. 4–5)
The Picture Bus Priority lines carry the digital priority selection signals. The priority interface allows digital switching of up to 8 sources to the backend processor. Switching for different sources is prioritized and can be done from pixel to pixel.

Pin 20...24 – Picture Bus Color Address, **COLOR[4:0]** (Fig. 4–16)
The Picture Bus COLOR lines carry the digital RGB color data. They are used as address for the color lookup table.

Pin 25 – Ground (Digital Shield), **DSGND**.

Pin 26, 27 – Range Switch for Measurement ADC, **RSW1, RSW2** (Fig. 4–19)
These pins are open drain pull-down outputs. RSW1 is switched off during cutoff and whitedrive measurement. RSW2 is switched off during cutoff measurement only.

Pin 28 – Measurement ADC Input, **SENSE** (Fig. 4–15)
This is the input of the analog digital converter for the picture and tube measurement.

Pin 29 – Ground (Measurement ADC Reference Input), **GND_M**
This is the ground reference for the measurement A/D converter.

Pin 30 – Ground (Vertical Sawtooth Output), **GND_V** (Fig. 4–20)
This is the ground reference for the vertical outputs.

Pin 31 – Vertical Sawtooth Output, **VERT** (Fig. 4–20)
This pin supplies the drive signal for the vertical output stage. The drive signal is generated with 15-bit precision by the Fast Processor in the front-end. The analog voltage is generated by a 4-bit current-DAC with external resistor and uses digital noise shaping.

Pin 32 – East-West Parabola Output, **EW** (Fig. 4–20)
This pin supplies the parabola signal for the East-West correction. The drive signal is generated with 15 bit precision by the Fast Processor in the front-end. The analog voltage is generated by a 4-bit current-DAC with external resistor and uses digital noise shaping.

Pin 33 – DAC Current Reference, **XREF** (Fig. 4–21)
External reference resistor for DAC output currents, typical 10 kΩ to adjust the output current of the D/A converters (see recommended operating conditions). This resistor has to be connected to analog ground as closely as possible to the pin.

Pin 34 – Scan Velocity Modulation Output, **SVMOUT** (Fig. 4–17)
This output delivers the analog SVM signal. The D/A converter is a current sink like the RGB D/A converters. At zero signal the output current is 50% of the maximum output current.

Pin 35 – Ground (Analog Back-end), **GND_O**

Pin 36 – Supply Voltage (Analog Back-end), **VSUP_O**

Pin 37, 38, 39 – Analog RGB Outputs, **ROUT, GOUT, BOUT** (Fig. 4–17)
These are the analog Red/Green/Blue outputs of the backend. The outputs sink a current of max. 8mA.

Pin 40 – DAC Reference Decoupling, **VRD** (Fig. 4–21)
Via this pin the DAC reference voltage is decoupled by an external capacitance. The DAC output currents depend on this voltage, therefore a pull-down transistor can be used to shut off all beam currents. A decoupling capacitor of 3.3μF//100nF is required.

Pin 41, 42, 43, 45, 46, 47 – Analog RGB Inputs, **RIN1/2**, **GIN1/2**, **BIN1/2** (Fig. 4–15)

These pins are used to insert an external analog RGB signal, e.g. from a SCART connector which can be switched to the analog RGB outputs with the fast blank signal. The analog backend provides separate brightness and contrast settings for the external analog RGB signals.

Pin 44, 48 – Fast Blank Inputs, **FBLIN1/2** (Fig. 4–15)
These pins are used to switch the RGB outputs to the external analog RGB inputs.

Pin 49 – Main Clock Output, **CLK20** (Fig. 4–4)
This is the 20.25MHz main system clock, that is used by all circuits in a high-end VDP system. All external timing is derived from this clock.

Pin 50 – Horizontal Drive Output, **HOUT** (Fig. 4–18)
This open drain output supplies the the drive pulse for the horizontal output stage. The polarity and gating with the flyback pulse are selectable by software.

Pin 51, 52 – Crystal Input and Output, **XTAL1**, **XTAL2** (Fig. 4–7)
These pins are connected to an 20.25 MHz crystal oscillator is digitally tuned by integrated shunt capacitances. The Clk20 and Clk5 clock signals are derived from this oscillator. An external clock can be fed into XTAL1. In this case clock frequency adjustment must be switched off.

Pin 53 – Standby Supply Voltage, **VSTBY**
In standby mode, only the clock oscillator and the horizontal drive circuitry are active.

Pin 54 – CCU 5 MHz Clock Output, **CLK5** (Fig. 4–10)
This pin provides a clock frequency for the TV microcontroller, e.g. a CCU3000 controller.

Pin 55 – Ground (Analog Front-end), **GND_F**

Pin 56 – Ground (Analog Signal Input), **ISGND** (Fig. 4–8)
This is the high quality ground reference for the video input signals.

Pin 57 – Reference Voltage Top, **VRT** (Fig. 4–8)
Via this pin, the reference voltage for the A/D converters is decoupled. The pin is connected with 10 µF/47 nF to the Signal Ground Pin.

Pin 58 – Supply Voltage (Analog Front-end), **VSUP_F**

Pin 59 – Analog Video Output, **VOUT** (Fig. 4–6)
The analog video signal that is selected for the main (luma, cvbs) adc is output at this pin. An emitter follower is required at this pin.

Pin 60 – Analog Chroma Input, **CIN** (Fig. 4–9)
This pin is connected to the S-VHS chroma signal. A resistive divider is used to bias the input signal to the middle of the converter input range. CIN can only be connected to the chroma (Video 2) A/D converter. The signal must be AC-coupled.

Pin 61...64 – Analog Video Input 1–4, **VIN1–4** (Fig. 4–11)
These are the analog video inputs. A CVBS or S-VHS luma signal is converted using the luma (Video 1) AD converter. The input signal must be AC-coupled.

4.4. Pin Configuration

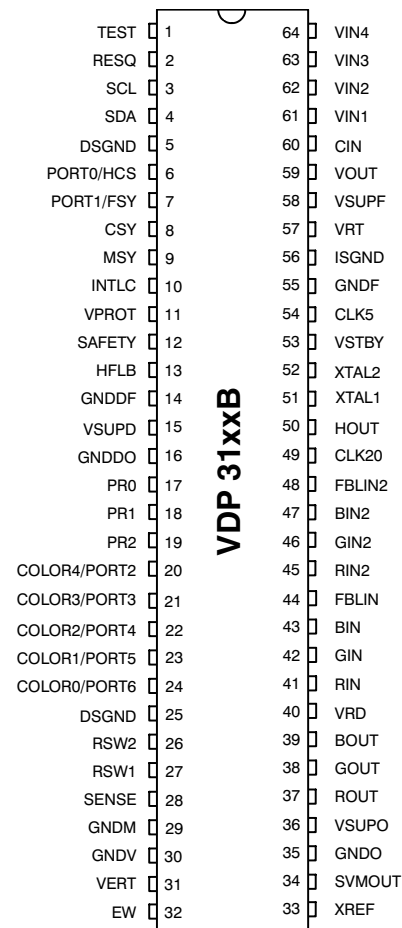

Fig. 4–2: 64-pin PSDIP package

4.5. Pin Circuits

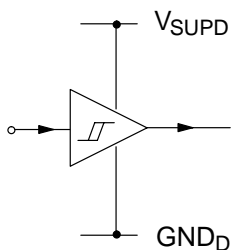

Fig. 4-3: Input pins RESQ, TEST

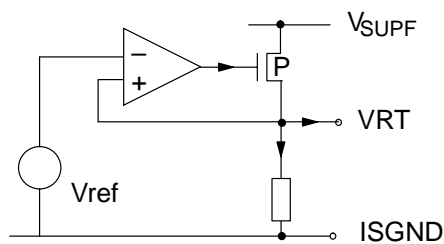

Fig. 4-8: Pins VRT , ISGND

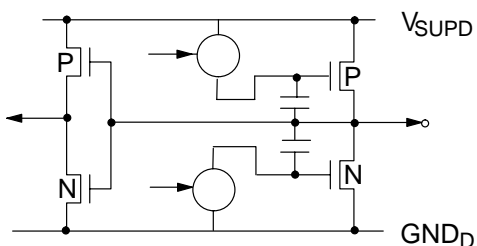

Fig. 4-4: Output pin CLK20

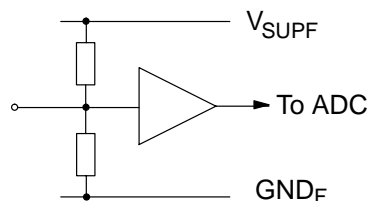

Fig. 4-9: Chroma input CIN

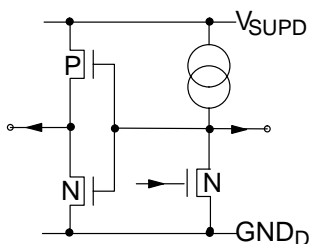

Fig. 4-5: Input/Output pins PR[2:0]

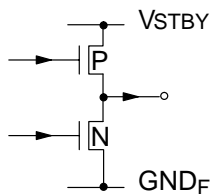

Fig. 4-10: Output pin CLK5

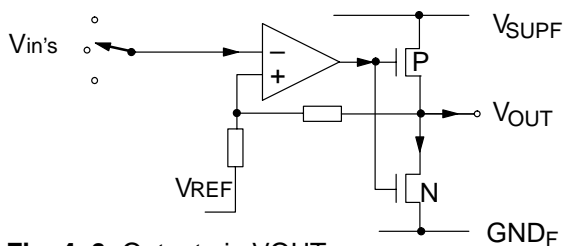

Fig. 4-6: Output pin VOUT

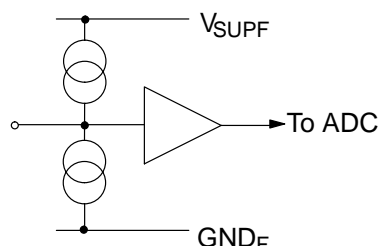

Fig. 4-11: Input pins VIN1-VIN4

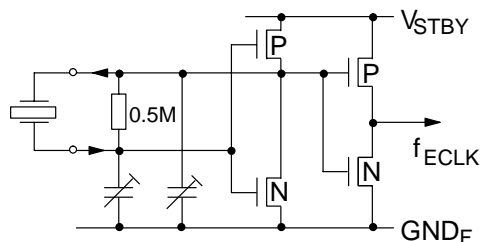

Fig. 4-7: Input/Output pins XTAL1, XTAL2

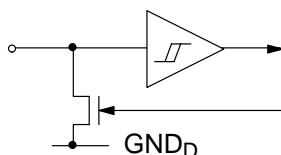

Fig. 4-12: Pins SDA, SCL

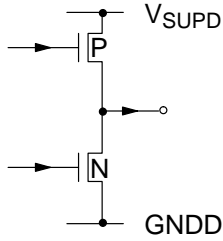

Fig. 4-13: Output pins FSY, MSY, CSY, INTLC, PORT[6:0]

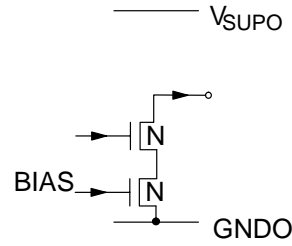

Fig. 4-17: Analog output pins ROUT, GOUT, BOUT, SVMOUT

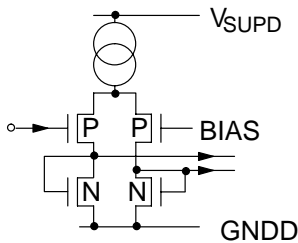

Fig. 4-14: Input pins SAFETY, VPROT, HFLB

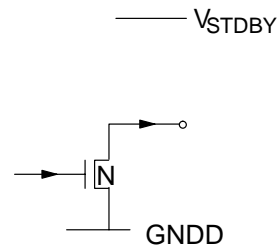

Fig. 4-18: Output pin HOUT

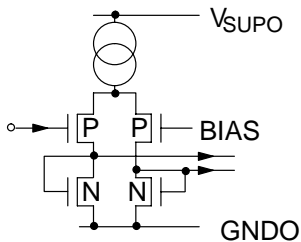

Fig. 4-15: Input pins FBLIN1/2, RIN1/2, BIN1/2, GIN1/2, SENSE

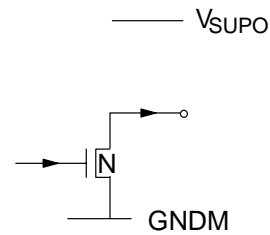

Fig. 4-19: Output pins RSW1, RSW2

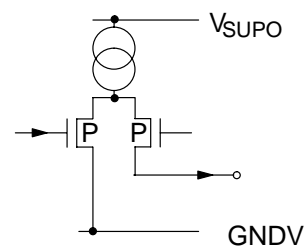

Fig. 4-20: Output pins VERT, EW

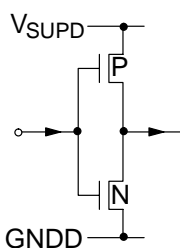

Fig. 4-16: Input pins COLOR[4:0], HCS, PORT[6:0]

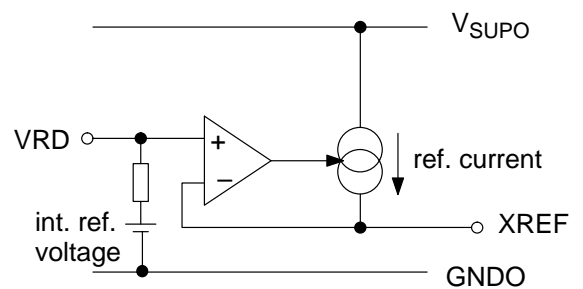

Fig. 4-21: Input pins XREF, VRD

4.6. Electrical Characteristics

4.6.1. Absolute Maximum Ratings

| Symbol | Parameter | Pin No. | Min. | Max. | Unit |
|-----------|-----------------------------------|---------|------|---------------|------|
| T_A | Ambient Operating Temperature | – | 0 | 65 | °C |
| T_S | Storage Temperature | – | –40 | 125 | °C |
| V_{SUP} | Supply Voltage, all Supply Inputs | | –0.3 | 6 | V |
| V_I | Input Voltage, all Inputs | | –0.3 | $V_{SUP}+0.3$ | V |
| V_O | Output Voltage, all Outputs | | –0.3 | $V_{SUP}+0.3$ | V |

Stresses beyond those listed in the “Absolute Maximum Ratings” may cause permanent damage to the device. This is a stress rating only. Functional operation of the device at these or any other conditions beyond those indicated in the “Recommended Operating Conditions/Characteristics” of this specification is not implied. Exposure to absolute maximum ratings conditions for extended periods may affect device reliability.

4.6.2. Recommended Operating Conditions

| Symbol | Parameter | Pin Name | Min. | Typ. | Max. | Unit |
|------------|-------------------------------------|----------|------|-------|------|------------|
| T_A | Ambient Operating Temperature | – | 0 | – | 65 | °C |
| V_{SUP} | Supply Voltages, all Supply Pins | | 4.75 | 5.0 | 5.25 | V |
| f_{XTAL} | Clock Frequency | XTAL1/2 | – | 20.25 | – | MHz |
| R_{xref} | RGB – DAC Current defining Resistor | XREF | 9.5 | 10 | 10.5 | k Ω |
| NS_{VDD} | Negative Slope of VDD (power down) | VSUPD | | | 0.2 | V/ μ s |

4.6.3. Recommended Crystal Characteristics

| Symbol | Parameter | Min. | Typ. | Max. | Unit |
|------------------|--|------|-----------|----------|----------|
| T_A | Operating Ambient Temperature | 0 | – | 65 | °C |
| f_P | Parallel Resonance Frequency with Load Capacitance $C_L = 13$ pF | – | 20.250000 | – | MHz |
| $\Delta f_P/f_P$ | Accuracy of Adjustment | – | – | ± 20 | ppm |
| $\Delta f_P/f_P$ | Frequency Temperature Drift | – | – | ± 30 | ppm |
| R_R | Series Resistance | – | – | 25 | Ω |
| C_0 | Shunt Capacitance | 3 | – | 7 | pF |
| C_1 | Motional Capacitance | 20 | – | 30 | fF |

Recommended Crystal Characteristics, continued

| Symbol | Parameter | Min. | Typ. | Max. | Unit |
|--|--|------|------|------|------|
| Load Capacitance Recommendation | | | | | |
| C _{Lext} | External Load Capacitance ¹⁾ from pins to Ground (pin names: Xtal1 Xtal2) | – | 3.3 | – | pF |
| DCO Characteristics ²⁾ | | | | | |
| C _{ICLoadmin} | Effective Load Capacitance @ min. DCO-Position, Code 0, | 3.6 | 4.3 | 5 | pF |
| C _{ICLoadrng} | Effective Load Capacitance Range, DCO Codes from 0..255 | 11.7 | 12.7 | 13.7 | pF |

1) Remarks on defining the External Load Capacitance:

External capacitors at each crystal pin to ground are required. They are necessary to tune the effective load capacitance of the PCBs to the required load capacitance C_L of the crystal. The higher the capacitors, the lower the clock frequency results. The nominal free running frequency should match f_p MHz. Due to different layouts of customer PCBs the matching capacitor size should be determined in the application. The suggested value is a figure based on experience with various PCB layouts.

Tuning condition: Code DVCO Register = –720

2) Remarks on Pulling Range of DCO:

The pulling range of the DCO is a function of the used crystal and effective load capacitance of the IC (C_{ICLoad} + C_{LoadBoard}). The resulting frequency f_L with an effective load capacitance of C_{Leff} = C_{ICLoad} + C_{LoadBoard} is

$$f_L = f_p * \frac{1 + 0.5 * [C_1 / (C_0 + C_{Leff})]}{1 + 0.5 * [C_1 / (C_0 + C_L)]}$$

4.6.4. Characteristics

at T_A = 0 to 65 °C, V_{SUPD/F/O} = 4.75 to 5.25 V, f = 20.25 MHz for min./max. values

at T_C = 60 °C, V_{SUPD/F/O} = 5 V, f = 20.25 MHz for typical values

| Symbol | Parameter | Pin Name | Min. | Typ. | Max. | Unit |
|---------------------|--------------------------------|--------------------|------|------|------|------|
| I _{VSUPF} | Current Consumption | V _{SUPF} | – | 38 | – | mA |
| I _{VSUPD} | Current Consumption | V _{SUPD} | – | 123 | – | mA |
| I _{VSUPO} | Current Consumption | V _{SUPO} | – | 64 | – | mA |
| I _{VSTDBY} | Current Consumption | V _{STDBY} | – | 3.3 | – | mA |
| P _{TOT} | Total Power Dissipation | | – | 1145 | 1200 | W |
| IL | Input / Output Leakage Current | All I/O Pins | –1 | – | 1 | µA |

4.6.4.1. 5 MHz Clock Output

| Symbol | Parameter | Pin Name | Min. | Typ. | Max. | Unit | Test Conditions |
|----------|------------------------|----------|------|------|-------------|------|----------------------------|
| V_{OL} | Output Low Voltage | CLK5 | – | – | 0.4 | V | $I_{OL} = 0.4 \text{ mA}$ |
| V_{OH} | Output High Voltage | | 4.0 | – | V_{STDBY} | V | $-I_{OL} = 0.9 \text{ mA}$ |
| t_{OT} | Output Transition Time | | – | 50 | – | ns | $C_{LOAD} = 30 \text{ pF}$ |

4.6.4.2. 20 MHz Clock Input/Output, External Clock Input (XTAL1) (see Fig. 4–22)

| Symbol | Parameter | Pin Name | Min. | Typ. | Max. | Unit | Test Conditions |
|-------------------------------------|--|----------|-------------------|-------------|---------------------------|------|----------------------------|
| V_{DCAV} | DC Average | CLK20 | $V_{SUP}/2 - 0.3$ | $V_{SUP}/2$ | $V_{SUP}/2 + 0.3$ | V | $C_{LOAD} = 30 \text{ pF}$ |
| V_{PP} | V_{OUT} Peak to Peak | | 1.3 | 1.6 | – | V | $C_{LOAD} = 30 \text{ pF}$ |
| t_{OT} | Output Transition Time | | – | – | 18 | ns | $C_{LOAD} = 30 \text{ pF}$ |
| V_{IT} | Input Trigger Level | | 2.1 | 2.5 | 2.9 | V | only for test purposes |
| f_{Φ} | Φ Main Clock Frequency | XTAL 1 | 10 | 20.25 | 24 | MHz | |
| $V_{\Phi MIDC}$ | Φ Main Clock Input DC Voltage | | 1.0 | – | 3.5 | V | |
| $V_{\Phi MIAC}$ | Φ M Clock Input AC Voltage (p-p) | | 0.8 | – | 2.5 | V | |
| $\frac{t_{\Phi MIH}}{t_{\Phi MIL}}$ | Φ M Clock Input High/Low Ratio | | 0.9 | 1.0 | 1.1 | | |
| $t_{\Phi MIHL}$ | Φ M Clock Input High to Low Transition Time | | – | – | $\frac{0.15}{f_{\Phi M}}$ | | |
| $t_{\Phi MILH}$ | Φ M Clock Input Low to High Transition Time | | – | – | $\frac{0.15}{f_{\Phi M}}$ | | |

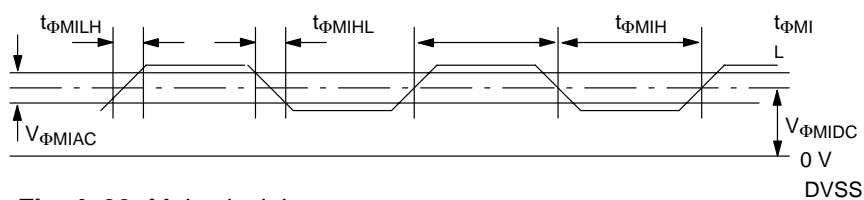

Fig. 4–22: Main clock input

4.6.4.3. Reset Input, Test Input

| Symbol | Parameter | Pin Name | Min. | Typ. | Max. | Unit | Test Conditions |
|----------|--------------------|--------------|------|------|------|------|-----------------|
| V_{IL} | Input Low Voltage | RESQ TEST | – | – | 1.5 | V | |
| V_{IH} | Input High Voltage | | 3.0 | – | – | V | |

4.6.4.4. I²C Bus Interface

| Symbol | Parameter | Pin Name | Min. | Typ. | Max. | Unit | Test Conditions |
|----------------------|------------------------------|----------|------|------|------------|--------|--|
| V _{IL} | Input Low Voltage | SDA, SCL | – | – | 1.5 | V | |
| V _{IH} | Input High Voltage | | 3.0 | – | – | V | |
| V _{OL} | Output Low Voltage | | – | – | 0.4 0.6 | V V | I _I = 3 mA I _I = 6 mA |
| V _{IH} | Input Capacitance | | – | – | 4 | pF | |
| t _F | Signal Fall Time | | – | – | 300 | ns | C _L = 400 pF |
| t _R | Signal Rise Time | | – | – | 300 | ns | C _L = 400 pF |
| f _{SCL} | Clock Frequency | SCL | 0 | – | 400 | kHz | |
| t _{LOW} | Low Period of SCL | | 1.3 | – | – | μs | |
| t _{HIGH} | High Period of SCL | | 0.6 | – | – | μs | |
| t _{SU Data} | Data Set Up Time to SCL high | SDA | 100 | – | – | ns | |
| t _{HD Data} | DATA Hold Time to SCL low | | 0 | – | 0.9 | μs | |

4.6.4.5. IO Port Expander

| Symbol | Parameter | Pin Name | Min. | Typ. | Max. | Unit | Test Conditions |
|-----------------|------------------------|-----------|----------------------------|------|-------------------|------|---|
| V _{IL} | Input Low Voltage | PORT[6:0] | – | – | 0.8 | V | |
| V _{IH} | Input High Voltage | | 1.5 | – | – | V | |
| V _{OL} | Output Low Voltage | | – | 0.2 | 0.4 | V | I _{OL} = 1.6 mA, strength 6 |
| V _{OH} | Output High Voltage | | V _{SUPD} – 0.4 | – | V _{SUPD} | V | –I _{OL} = 1.6mA, strength 6 |
| t _{OD} | Output Transition Time | | – | – | 35 | ns | C _{LOAD} = 70pF |
| I _{OL} | Output Current | | –10 | – | 10 | mA | driver imp. = 0 |

4.6.4.6. Analog Video Inputs

| Symbol | Parameter | Pin Name | Min. | Typ. | Max. | Unit | Test Conditions |
|------------------|--|-------------------------------------|------|------|------|------|-----------------|
| V _{VIN} | Analog Input Voltage | VIN1 VIN2 VIN3 VIN4 CIN | 0 | – | 3.5 | V | |
| C _{CP} | Input Coupling Capacitor Video Inputs | VIN1 VIN2 VIN3 VIN4 | – | 680 | – | nF | |
| C _{CP} | Input Coupling Capacitor Chroma Input | CIN | – | 1 | – | nF | |

4.6.4.7. Analog Front-End and ADCs

| Symbol | Parameter | Pin Name | Min. | Typ. | Max. | Unit | Test Conditions | |
|---|---|-------------------------------------|------|-------|-----------|-----------------|---|--|
| V _{VRT} | Reference Voltage Top | VRT | 2.5 | 2.6 | 2.8 | V | 10 μ F/10 nF, 1 G Ω Probe | |
| Luma – Path | | | | | | | | |
| R _{VIN} | Input Resistance | VIN1 VIN2 VIN3 VIN4 | 1 | | | M Ω | Code Clamp – DAC = 0 | |
| C _{VIN} | Input Capacitance | | | 4.5 | | | | pF |
| V _{VIN} | Full Scale Input Voltage | | 1.8 | 2.0 | 2.2 | V _{PP} | min. AGC Gain | |
| V _{VIN} | Full Scale Input Voltage | | 0.5 | 0.6 | 0.7 | V _{PP} | max. AGC Gain | |
| AGC | AGC Step Width | | | 0.166 | | dB | 6-Bit Resolution = 64 Steps f _{sig} = 1 MHz, –2 dBr of max. AGC-Gain | |
| DNL _{AGC} | AGC Differential Non-Linearity | | | | ± 0.5 | LSB | | |
| V _{VINCL} | Input Clamping Level, CVBS | | | 1.0 | | V | Binary Level = 64 LSB min. AGC Gain | |
| Q _{CL} | Clamping DAC Resolution | | | –16 | | 15 | steps | 5 Bit – I-DAC, bipolar V _{VIN} = 1.5 V |
| I _{CL-LSB} | Input Clamping Current per Step | | | 0.7 | 1.0 | 1.3 | μ A | |
| DNL _{ICL} | Clamping DAC Differential Non-Linearity | | | | | ± 0.5 | LSB | |
| C _{ICL} | Clamping-Capacity | | | 220 | – | nF | Coupling-Cap. @ Inputs | |
| Chroma – Path | | | | | | | | |
| R _{CIN} | Input Resistance SVHS Chroma | CIN VIN1 | 1.4 | 2.0 | 2.6 | k Ω | | |
| V _{CIN} | Full Scale Input Voltage, Chroma | | 1.08 | 1.2 | 1.32 | V _{PP} | | |
| V _{CINDC} | Input Bias Level, SVHS Chroma | | – | 1.5 | – | V | | |
| | Binary Code for Open Chroma Input | | | 128 | | | | |
| Dynamic Characteristics for all Video Paths (Luma + Chroma) | | | | | | | | |
| BW | Bandwidth | VIN1 VIN2 VIN3 VIN4 CIN | 10 | 12.5 | | MHz | –2 dBr input signal level | |
| XTALK | Crosstalk, any Two Video Inputs | | | –56 | | | dB | 1 MHz, –2 dBr signal level |
| THD | Total Harmonic Distortion | | | 50 | | | dB | 1 MHz, 5 harmonics, –2 dBr signal level |
| SINAD | Signal to Noise and Distortion Ratio | | | 45 | | | dB | 1 MHz, all outputs, –2 dBr signal level |
| INL | Integral Non-Linearity, | | | | | ± 1 | LSB | Code Density, DC-ramp |
| DNL | Differential Non-Linearity | | | | | ± 0.8 | LSB | |
| DG | Differential Gain | | | | | ± 3 | % | –12 dBr, 4.4 MHz signal on DC- ramp |
| DP | Differential Phase | | | | | 1.5 | deg | |

Analog Front-End and ADCs, continued

| Symbol | Parameter | Pin Name | Min. | Typ. | Max. | Unit | Test Conditions | |
|---------------------|--|------------------|------|-------|------|-----------------|---|--|
| Analog Video Output | | | | | | | | |
| V _{OUT} | Output Voltage | V _{OUT} | 1.7 | 2.0 | 2.3 | V _{PP} | V _{VIN} = 1 V _{PP} , AGC = 0 dB | |
| AGC _{VOUT} | AGC Step Width, V _{OUT} | | | 1.333 | | | dB | 3 Bit Resolution = 7 Steps 3 MSB's of main AGC |
| DNL _{AGC} | AGC Differential Non-Linearity | | | | ±0.5 | | LSB | |
| V _{OUTDC} | DC-Level | | | 1 | | | V | clamped to back porch |
| BW | V _{OUT} Bandwidth | | | 10 | | | MHz | Input: -2 dB _r of main ADC range, C _L ≤ 10 pF |
| THD | V _{OUT} Total Harmonic Distortion | | | | -45 | -40 | dB | Input: -2 dB _r of main ADC range, C _L ≤ 10 pF 1 MHz, 5 Harmonics |
| C _{LVOUT} | Load Capacitance | | | - | - | 10 | pF | |
| I _{LVOUT} | Output Current | | | - | - | ±0.1 | mA | |

4.6.4.8. Picture Bus Input (see Fig. 4-23)

| Symbol | Parameter | Pin Name | Min. | Typ. | Max. | Unit | Test Conditions |
|-----------------|--------------------|----------------------------|------|------|------|------|-----------------|
| V _{IL} | Input Low Voltage | PR[2:0] COL- OR[4:0] | - | - | 0.8 | V | |
| V _{IH} | Input High Voltage | | 1.5 | - | - | V | |
| t _{IS} | Input Setup Time | | 7 | - | - | ns | |
| t _{IH} | Input Hold Time | | 5 | - | - | ns | |

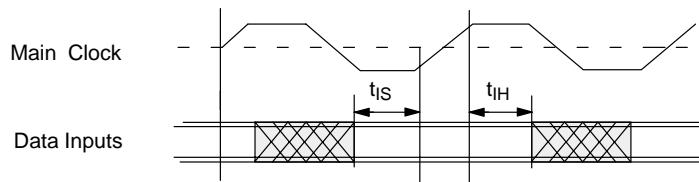

Fig. 4-23: Picture bus input timing

4.6.4.9. INTLC, Front Sync Output

| Symbol | Parameter | Pin Name | Min. | Typ. | Max. | Unit | Test Conditions |
|-----------------|---------------------|--------------|----------------------------|------|-------------------|------|---|
| V _{OL} | Output Low Voltage | INTLC FSY | – | 0.2 | 0.4 | V | I _{OL} = 1.6 mA, strength 6 |
| V _{OH} | Output High Voltage | | V _{SUPD} – 0.4 | – | V _{SUPD} | V | –I _{OL} = 1.6mA, strength 6 |
| t _{OH} | Output Hold Time | | 6 | 14 | | ns | C _{LOAD} = 70pF |
| t _{OD} | Output Delay Time | | – | – | 35 | ns | C _{LOAD} = 70pF |
| I _{OL} | Output Current | | –10 | – | 10 | mA | driver imp. = 0 |

4.6.4.10. Main Sync Output

| Symbol | Parameter | Pin Name | Min. | Typ. | Max. | Unit | Test Conditions |
|-----------------|---------------------|----------|----------------------------|------|-------------------|------|---|
| V _{OL} | Output Low Voltage | MSY | – | 0.2 | 0.4 | V | I _{OL} = 1.6 mA, strength 6 |
| V _{OH} | Output High Voltage | | V _{SUPD} – 0.4 | – | V _{SUPD} | V | –I _{OL} = 1.6mA, strength 6 |
| t _{OH} | Output Hold Time | | 6 | 14 | | ns | C _{LOAD} = 70pF |
| t _{OD} | Output Delay Time | | – | – | 35 | ns | C _{LOAD} = 70pF |
| I _{OL} | Output Current | | –10 | – | 10 | mA | driver imp. = 0 |

4.6.4.11. Combined Sync Output

| Symbol | Parameter | Pin Name | Min. | Typ. | Max. | Unit | Test Conditions |
|-----------------|------------------------|----------|----------------------------|------|-------------------|------|---|
| V _{OL} | Output Low Voltage | CSY | – | – | 0.4 | V | I _{OL} = 1.6 mA strength 6 |
| V _{OH} | Output High Voltage | | V _{SUPD} – 0.4 | – | V _{SUPD} | V | –I _{OL} = 1.6 mA strength 6 |
| t _{OT} | Output Transition Time | | – | 10 | 20 | ns | C _{LOAD} = 30 pF |
| I _{OL} | Output Current | | –10 | – | 10 | mA | driver imp. = 0 |

4.6.4.12. Horizontal Flyback Input

| Symbol | Parameter | Pin Name | Min. | Typ. | Max. | Unit | Test Conditions |
|--------------------|---|----------|------|------|------|------|-----------------|
| V _{IL} | Input Low Voltage | HFLB | – | – | 1.8 | V | |
| V _{IH} | Input High Voltage | | 2.6 | – | – | V | |
| V _{IHST} | Input Hysteresis | | 0.1 | – | – | V | |
| PSRR _{HF} | Power Supply Rejection Ratio of Trigger Level | | 0 | | | dB | f = 20 MHz |
| PSRR _{MF} | Power Supply Rejection Ratio of Trigger Level | | –20 | | | dB | f < 15 kHz |
| PSRR _{LF} | Power Supply Rejection Ratio of Trigger Level | | –40 | | | dB | f < 100 Hz |
| t _{PID} | Internal Delay | | | | | 12 | ns |

4.6.4.13. Horizontal Drive Output

| Symbol | Parameter | Pin Name | Min. | Typ. | Max. | Unit | Test Conditions |
|-----------------|--|----------|------|------|------|------|---------------------------|
| V _{OL} | Output Low Voltage | HOUT | – | – | 0.4 | V | I _{OL} = 10 mA |
| V _{OH} | Output High Voltage (Open Drain Stage) | | – | – | 5 | V | external pull-up resistor |
| t _{oF} | Output Fall Time | | – | 8 | 20 | ns | C _{LOAD} = 30pF |
| I _{OL} | Output Low Current | | – | – | 10 | mA | |

4.6.4.14. Vertical Protection Input

| Symbol | Parameter | Pin Name | Min. | Typ. | Max. | Unit | Test Conditions |
|-------------------|--------------------|----------|------|------|------|------|-----------------|
| V _{IL} | Input Low Voltage | VPROT | – | – | 1.8 | V | |
| V _{IH} | Input High Voltage | | 2.6 | – | – | V | |
| V _{IHST} | Input Hysteresis | | 0.1 | – | – | V | |

4.6.4.15. Vertical Safety Input

| Symbol | Parameter | Pin Name | Min. | Typ. | Max. | Unit | Test Conditions |
|-------------------|--------------------------|----------|------|------|------|------|-----------------|
| V _{ILA} | Input Low Voltage A | SAFETY | – | – | 1.8 | V | |
| V _{IHA} | Input High Voltage A | | 2.6 | – | – | V | |
| V _{ILB} | Input Low Voltage B | | – | – | 3.1 | V | |
| V _{IHB} | Input High Voltage B | | 3.9 | – | – | V | |
| V _{IHST} | Input Hysteresis A and B | | 0.1 | – | – | V | |
| t _{PID} | Internal Delay | | | | | 100 | ns |

4.6.4.16. Vertical and East/West Drive Output

| Symbol | Parameter | Pin Name | Min. | Typ. | Max. | Unit | Test Conditions |
|-------------------|-------------------------------|------------|------|------|------|------|---|
| V _{OL} | Output Voltage LOW | EW VERT | | 0 | | V | R _{load} = 6800 R _{xref} = 10 kΩ |
| V _{OH} | Output Voltage HIGH | | 2.82 | 3 | 3.2 | V | R _{load} = 6800 R _{xref} = 10 kΩ |
| I _{dacn} | Full scale DAC Output Current | | 415 | 440 | 465 | μA | V _o = 0 V R _{xref} = 10 kΩ |
| PSRR | Power Supply Rejection Ratio | | 20 | – | – | dB | |

4.6.4.17. Sense A/D Converter Input

| Symbol | Parameter | Pin Name | Min. | Typ. | Max. | Unit | Test Conditions |
|----------------------|-------------------------------|--------------|------|------|------------------|------|--|
| V _I | Input Voltage Range | SENSE | 0 | – | V _{sup} | V | |
| V _{I255} | Input Voltage for code 255 | | 1.4 | 1.54 | 1.7 | V | Read cutoff blue register |
| C ₀ | Digital Output for zero Input | | | | 16 | LSB | Offset check, read cutoff blue register |
| R _I | Input Impedance | | 1 | – | – | MΩ | |
| Range Switch Outputs | | | | | | | |
| R _{ON} | Output On Resistance | RSW1 RSW2 | – | – | 50 | Ω | I _{OL} = 10 mA |
| I _{Max} | Maximum Current | | – | – | 15 | mA | |
| I _{LEAK} | Leakage Current | | – | – | 600 | nA | RSW High Impedance |
| C _{IN} | Input Capacitance | | – | – | 4 | pF | |

4.6.4.18. Analog RGB and FB Inputs (continued on next page)

| Symbol | Parameter | Pin Name | Min. | Typ. | Max. | Unit | Test Conditions | |
|--------------------|---|---|------|------|------|-----------------|-------------------------|-----------------------|
| V _{RGBIN} | External RGB Inputs Voltage Range | RIN GIN BIN RIN2 GIN2 BIN2 | –0.3 | – | 1.1 | V | | |
| V _{RGBIN} | nominal RGB Input Voltage peak-to-peak | | 0.5 | 0.7 | 1.0 | V _{pp} | SCART Spec: 0.7 V ±3 dB | |
| V _{RGBIN} | RGB Inputs Voltage for Maximum Output Current | | | 0.44 | | | | Contrast setting: 511 |
| | RGB Inputs Voltage for Maximum Output Current | | | 0.7 | | | | Contrast setting: 323 |
| | RGB Inputs Voltage for Maximum Output Current | | 1.1 | | | | Contrast setting: 204 | |

Analog RGB and FB Inputs, continued

| Symbol | Parameter | Pin Name | Min. | Typ. | Max. | Unit | Test Conditions |
|---------------|---|---|-----------------|------|------|----------|---|
| C_{RGBIN} | External RGB Input Coupling Capacitor | RIN GIN BIN RIN2 GIN2 BIN2 | | 15 | | nF | |
| | Clamp Pulse Width | | 3.1 | | | μ s | |
| C_{IN} | Input Capacitance | | – | – | 13 | pF | |
| I_{IL} | Input Leakage Current | | –0.5 | – | 0.5 | μ A | Clamping OFF, $V_{IN} -0.3..3$ V |
| V_{CLIP} | RGB Input Voltage for Clipping Current | | | 2 | | V | |
| V_{CLAMP} | Clamp Level at Input | | 40 | 60 | 80 | mV | Clamping ON |
| V_{INOFF} | Offset Level at Input | | –10 | | 10 | mV | Extrapolated from $V_{IN} = 100$ mV and 200 mV |
| V_{INOFF} | Offset Level Match at Input | | –10 | | 10 | mV | Extrapolated from $V_{IN} = 100$ mV and 200 mV |
| R_{CLAMP} | Clamping-ON-Resistance | | | 140 | – | Ω | |
| V_{FBLOFF} | FBLIN Low Level | | FBLIN FBLIN2 | – | – | 0.5 | V |
| V_{FBLON} | FBLIN High Level | 0.9 | | – | – | V | |
| $V_{FBLTRIG}$ | Fast Blanking Trigger Level typical | | | 0.7 | | | |
| t_{PID} | Delay Fast Blanking to RGB_{OUT} from midst of FBLIN-transition to 90% of RGB_{OUT} -transition | | | 8 | 15 | ns | Internal RGB = 3.75 mA Full Scale Int. Brightness = 0 External Brightness = 1.5 mA (Full Scale) $RGB_{in} = 0$ $V_{FBLOFF} = 0.4$ V $V_{FBLON} = 1.0$ V Rise and fall time = 2 ns |
| | Difference of Internal Delay to External RGB_{in} Delay | –5 | | | +5 | ns | |
| | Switch-Over-Glitch | | | 0.5 | | pAs | Switch from 3.75 mA (int) to 1.5 mA (ext) |

4.6.4.19. Half Contrast Switch Input

| Symbol | Parameter | Pin Name | Min. | Typ. | Max. | Unit | Test Conditions |
|-----------|---|----------|------|------|------|------|---|
| V_{IL} | Input Low Voltage | HCS | – | – | 0.8 | V | |
| V_{IH} | Input High Voltage | | 1.5 | – | – | V | |
| t_{HCS} | Delay HCS to RGB_{OUT} from 50% of HCS-transition to 90% of RGB_{OUT} -transition | | | 80 | 120 | ns | Internal RGB = 3.75 mA $V_{HCSL} = 0.4$ V $V_{HCSh} = 1.0$ V Rise and fall time = 2 ns |

4.6.4.20. Analog RGB Outputs, D/A Converters

| Symbol | Parameter | Pin Name | Min. | Typ. | Max. | Unit | Test Conditions | |
|--|---|----------------------|------|------|------|-------------------|--|--|
| Internal RGB Signal D/A Converter Characteristics | | | | | | | | |
| | Resolution | ROUT GOUT BOUT | – | 10 | – | bit | | |
| I _{OUT} | Full Scale Output Current | | 3.6 | 3.75 | 3.9 | mA | R _{ref} = 10 kΩ | |
| I _{OUTH} C | Half Contrast Output Current | | 1.74 | 1.87 | 2.0 | mA | R _{ref} = 10 kΩ, I _{OUT} = 3.75 mA | |
| | Differential Nonlinearity | | | | 0.5 | LSB | | |
| | Integral Nonlinearity | | | | 1 | LSB | | |
| | Glitch Pulse Charge | | | 0.5 | | pAs | Ramp signal, 25 Ω output termination | |
| t _T | Rise and Fall Time | | | 3 | | ns | 10% to 90%, 90% to 10% | |
| t _{RHC} | Half Contrast Rise Time | | | 50 | 75 | ns | 60% to 90% I _{OUT} = 3.75mA | |
| t _{FHC} | Half Contrast Fall Time | | | 25 | 40 | ns | 90% to 60% I _{OUT} = 3.75mA | |
| | Intermodulation | | | | –50 | dB | 2/2.5 MHz full scale | |
| | Signal to Noise | | | +50 | | dB | Signal: 1MHz full scale Bandwidth: 10MHz | |
| Δ _{RGB} | Matching R–G, R–B, G–B | | | –2 | | 2 | % | |
| Δ _{RGBHC} | Half Contrast Matching R–G, R–B, G–B | | | –5 | | 5 | % | |
| | R/B/G Crosstalk one channel talks two channels talk | | | | | –46 | dB | Passive channel: I _{OUT} = 1.88 mA Crosstalk-Signal: 1.25 MHz, 3.75 mA _{PP} |
| | RGB Input Crosstalk from external RGB one channel talks two channels talk three channels talk | | | | | –50 –50 –50 | dB dB dB | |
| Internal RGB Brightness D/A Converter Characteristics | | | | | | | | |
| | Resolution | ROUT GOUT BOUT | | 9 | | bits | | |
| I _{BR} | Full Scale Output Current relative | | 39.2 | 40 | 40.8 | % | Ref to max. digital RGB | |
| I _{BR} | Full Scale Output Current absolute | | | 1.5 | | mA | | |
| I _{BR} | differential nonlinearity | | | | 0.5 | LSB | | |
| I _{BR} | integral nonlinearity | | | | 1 | LSB | | |
| I _{BR} | Match R–G, R–B, G–B | | –2 | | 2 | % | | |
| I _{BR} | Match to digital RGB R–R, G–G, B–B | | –2 | | 2 | % | | |
| External RGB Voltage/Current Converter Characteristics | | | | | | | | |
| | Resolution | ROUT GOUT BOUT | | 9 | | bits | | |
| I _{EXOUT} | Full Scale Output Current relative | | 96 | 100 | 104 | % | Ref. to max. Digital RGB V _{IN} = 0.7 V _{PP} , contrast = 323 | |
| | Full Scale Output Current absolute | | | 3.75 | | mA | Same as Digital RGB | |

Analog RGB Outputs, D/A Converters, continued

| Symbol | Parameter | Pin Name | Min. | Typ. | Max. | Unit | Test Conditions |
|---|---|----------------------|------------|--------|------|----------|---|
| CR | Contrast Adjust Range | ROUT GOUT BOUT | | 16:511 | | | |
| | Gain Match R-G, R-B, G-B | | -2 | | 2 | % | Measured at RGB Outputs $V_{IN} = 0.7 V$, contrast = 323 |
| | Gain Match to RGB-DACs R-R, G-G, B-B | | -3 | | 3 | % | Measured at RGB Outputs $V_{IN} = 0.7 V$, contrast = 323 |
| | R/B/G Input Crosstalk one channel talks two channels talk | | | | -46 | dB | Passive channel: $V_{IN} = 0.7V$, contrast = 323 |
| | RGB Input Crosstalk from Internal RGB one channel talks two channels talk three channels talk | | | | -50 | dB | Crosstalk signal: 1.25 MHz, 3.75 mA _{PP} |
| | RGB Input Noise and Distortion | | | | -50 | dB | $V_{IN} = 0.7 V_{PP}$ at 1 MHz contrast = 323 Bandwidth: 10 MHz |
| | RGB Input Bandwidth -3dB | | 10 | 15 | - | MHz | $V_{IN} = 0.7 V_{PP}$, contrast = 323 |
| | RGB Input THD | | -50 -40 | | | dB dB | Input signal 1 MHz Input signal 6 MHz $V_{IN} = 0.7 V_{PP}$ contrast = 323 |
| | Differential Nonlinearity of Contrast Adjust | | | | 1.0 | LSB | $V_{IN} = 0.44 V$ |
| | Integral nonlinearity of Contrast Adjust | | | | 7 | LSB | |
| V _{RGBO} | RGB Output Voltage | | -1.0 | | 0.3 | V | Referred to V _{SUPO} |
| | RGB Output Load Resistance | | | | 100 | Ω | Ref. to V _{SUPO} |
| V _{OUTC} | RGB Output Compliance | | -1.5 | -1.3 | -1.2 | V | Ref. to V _{SUPO} Sum of max. Current of RGB-DACs and max. Cur- rent of Int. Brightness DACs is 2% degraded |
| External RGB Brightness D/A Converter Characteristics | | | | | | | |
| | Resolution | ROUT GOUT BOUT | | 9 | | bits | |
| I _{EXBR} | Full Scale Output Current relative | | 39.2 | 40 | 40.8 | % | Ref to max. digital RGB |
| | Full Scale Output Current absolute | | | 1.5 | | mA | |
| | Differential Nonlinearity | | | | 0.5 | LSB | |
| | Integral Nonlinearity | | | | 1 | LSB | |
| | Matching R-G, R-B, G-B | | -2 | | 2 | % | |
| | Matching to digital RGB R-R, G-G, B-B | | -2 | | 2 | % | |

Analog RGB Outputs, D/A Converters, continued

| Symbol | Parameter | Pin Name | Min. | Typ. | Max. | Unit | Test Conditions |
|---|---------------------------------------|----------------------|------|------|------|------|-------------------------|
| RGB Output Cutoff D/A Converter Characteristics | | | | | | | |
| | Resolution | ROUT GOUT BOUT | | 9 | | bits | |
| I _{CUT} | Full Scale Output Current relative | | 58.8 | 60 | 61.2 | % | Ref to max. digital RGB |
| I _{CUT} | Full Scale Output Current absolute | | | 2.25 | | mA | |
| I _{CUT} | Differential nonlinearity | | | | 0.5 | LSB | |
| I _{CUT} | Integral nonlinearity | | | | 1 | LSB | |
| I _{CUT} | Match to digital RGB R-R, G-G, B-B | | -2 | | 2 | % | |
| RGB Output Ultrablack D/A Converter Characteristics | | | | | | | |
| | Resolution | ROUT GOUT BOUT | | 1 | | bits | |
| I _{UB} | Full Scale Output Current relative | | 19.6 | 20 | 20.4 | % | Ref to max. digital RGB |
| | Full Scale Output Current absolute | | | 0.75 | | mA | |
| | Match to digital RGB R-R, G-G, B-B | | -2 | | 2 | % | |

4.6.4.21. DAC Reference, Beam Current Safety

| Symbol | Parameter | Pin Name | Min. | Typ. | Max. | Unit | Test Conditions |
|---------------------|---|----------|------|------|------|------|---------------------------|
| V _{DACREF} | DAC-Reference Voltage | VRD/BCS | 2.38 | 2.50 | 2.67 | V | |
| | DAC-Reference Output resistance | VRD/BCS | 18 | 25 | 32 | kΩ | |
| V _{XREF} | DAC-Reference Voltage Bias Current Generation | XREF | 2.25 | 2.34 | 2.43 | V | R _{ref} = 10 kΩ, |

4.6.4.22. Scan Velocity Modulation Output

| Symbol | Parameter | Pin Name | Min. | Typ. | Max. | Unit | Test Conditions |
|-----------------------------------|---------------------------|----------|------|-------|------|------|---|
| SVM D/A Converter Characteristics | | | | | | | |
| | Resolution | SVMOUT | | 8 | | bit | |
| I _{OUT} | Full Scale Output Current | | 1.55 | 1.875 | 2.25 | mA | |
| I _{OUT} | Differential Nonlinearity | | | | 0.5 | LSB | |
| I _{OUT} | Integral Nonlinearity | | | | 1 | LSB | |
| I _{OUT} | Glitch Pulse Charge | | | 0.5 | | pAs | Ramp, output line is terminated on both ends with 50 Ohms |
| I _{OUT} | Rise and Fall Time | | | 3 | | nsec | 10% to 90%, 90% to 10% |

5. Application Circuit

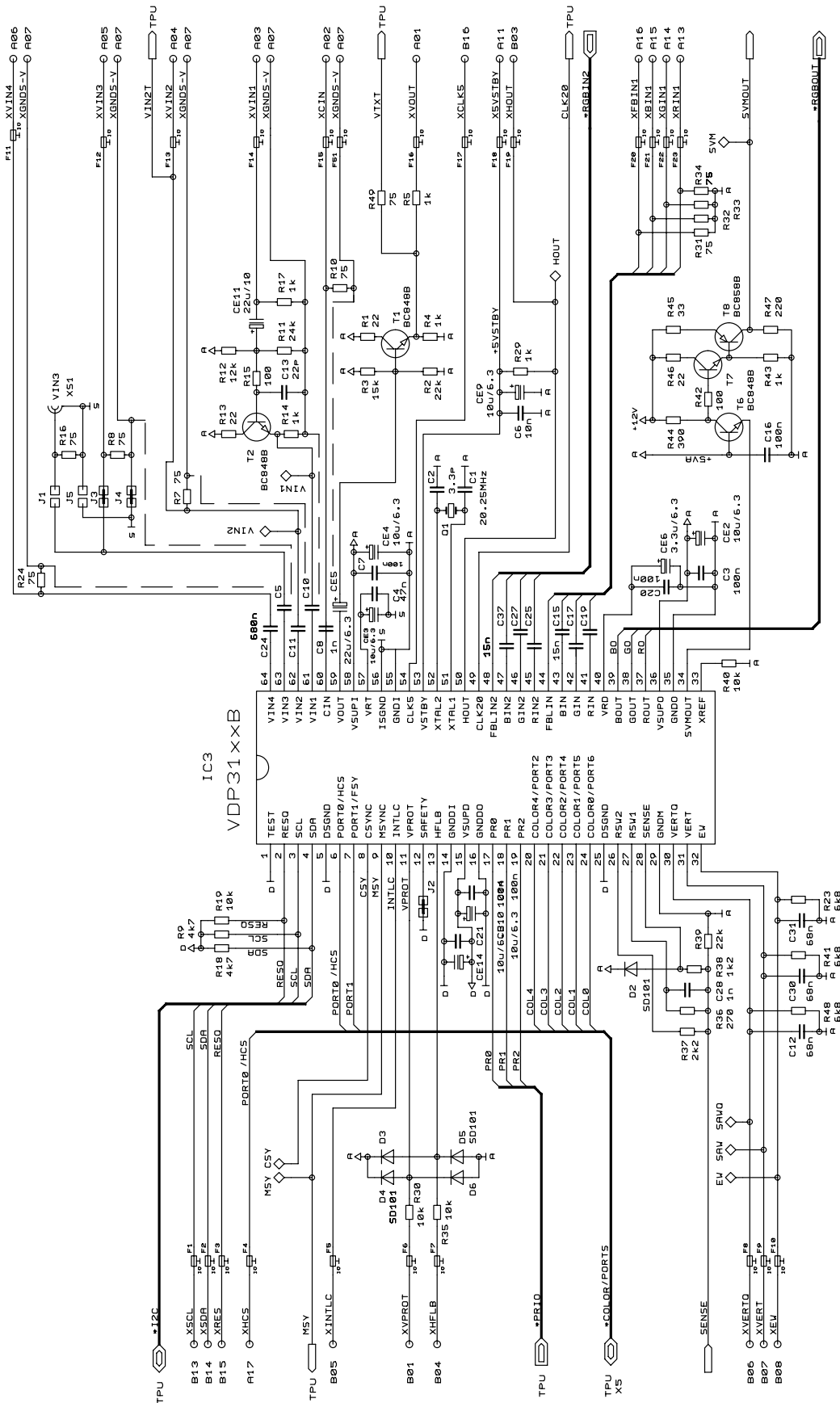

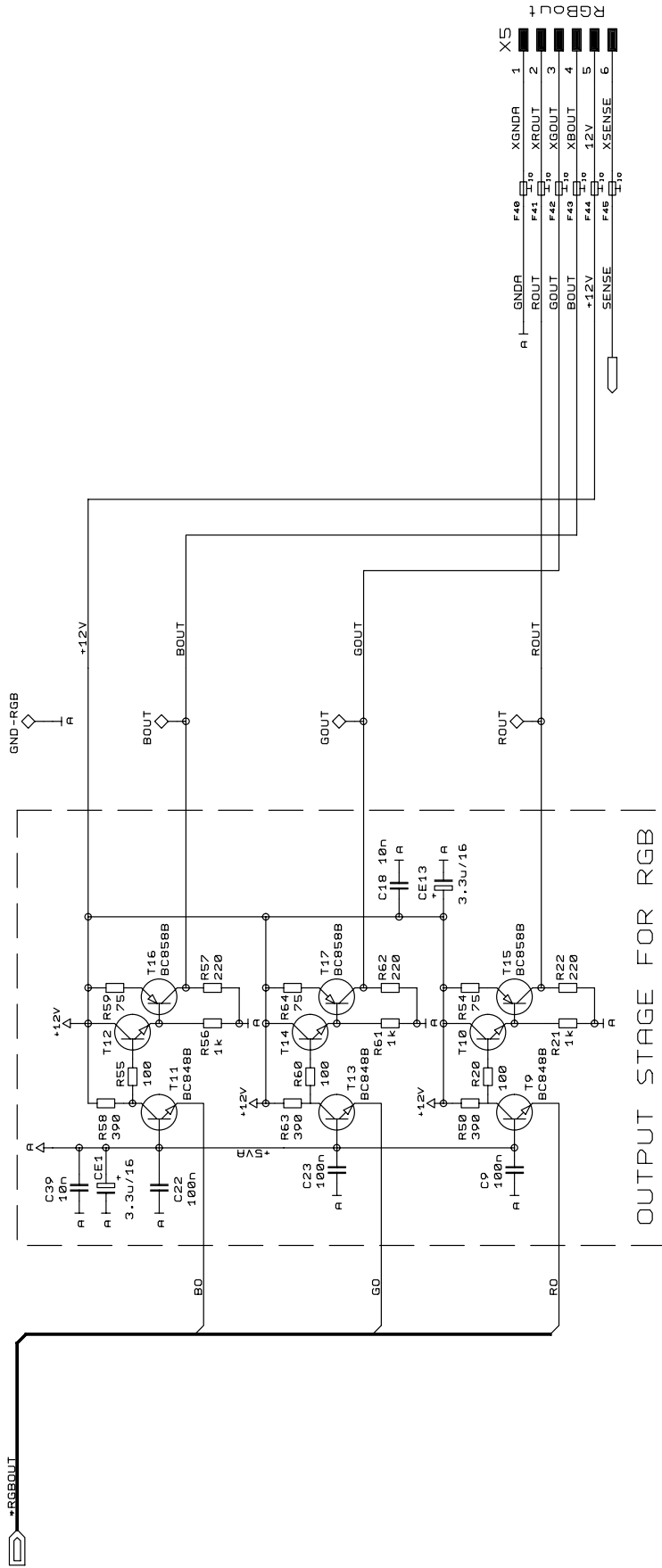

6. Data Sheet History

1. Preliminary data sheet: "VDP 31xxB Video Processor Family", Edition May 15, 1997, 6251-437-1PD.
First release of the preliminary data sheet.

2. Preliminary data sheet: "VDP 31xxB Video Processor Family", Edition Sept. 25, 1998, 6251-437-2PD.
Second release of the preliminary data sheet.
Major changes:

- section 4.1.: package outline dimensions changed
- section 4.6.: missing values have been defined
- section 5.: application circuit diagram corrected

Micronas GmbH
Hans-Bunte-Strasse 19
D-79108 Freiburg (Germany)
P.O. Box 840
D-79008 Freiburg (Germany)
Tel. +49-761-517-0
Fax +49-761-517-2174
E-mail: docservice@micronas.com
Internet: www.micronas.com

Printed in Germany
Order No. 6251-437-2PD

All information and data contained in this data sheet are without any commitment, are not to be considered as an offer for conclusion of a contract, nor shall they be construed as to create any liability. Any new issue of this data sheet invalidates previous issues. Product availability and delivery are exclusively subject to our respective order confirmation form; the same applies to orders based on development samples delivered. By this publication, Micronas GmbH does not assume responsibility for patent infringements or other rights of third parties which may result from its use.

Further, Micronas GmbH reserves the right to revise this publication and to make changes to its content, at any time, without obligation to notify any person or entity of such revisions or changes.

No part of this publication may be reproduced, photocopied, stored on a retrieval system, or transmitted without the express written consent of Micronas GmbH.