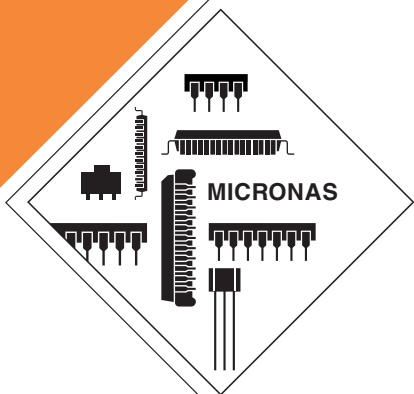


PRELIMINARY DATA SHEET

VPX 3225D,  
VPX 3224D  
Video Pixel Decoders



---

**Contents**

<b>Page</b>	<b>Section</b>	<b>Title</b>
<b>6</b>	<b>1.</b>	<b>Introduction</b>
7	1.1.	System Architecture
<b>8</b>	<b>2.</b>	<b>Functional Description</b>
8	2.1.	Analog Front-End
8	2.1.1.	Input Selector
8	2.1.2.	Clamping
8	2.1.3.	Automatic Gain Control
8	2.1.4.	Analog-to-Digital Converters
8	2.1.5.	ADC Range
8	2.1.6.	Digitally Controlled Clock Oscillator
10	2.2.	Color Decoder
10	2.2.1.	IF-Compensation
10	2.2.2.	Demodulator
11	2.2.3.	Chrominance Filter
11	2.2.4.	Frequency Demodulator
11	2.2.5.	Burst Detection
11	2.2.6.	Color Killer Operation
11	2.2.7.	PAL Compensation/1-H Comb Filter
12	2.2.8.	Luminance Notch Filter
13	2.3.	Video Sync Processing
13	2.4.	Macrovision Detection (version D4 only)
14	2.5.	Component Processing
15	2.5.1.	Horizontal Resizer
16	2.5.2.	Skew Correction
16	2.5.3.	Peaking and Coring
16	2.5.4.	YCbCr Color Space
16	2.5.5.	Video Adjustments
17	2.6.	Video Output Interface
17	2.6.1.	Output Formats
17	2.6.1.1.	YUV 4:2:2 with Separate Syncs/ITU-R601
18	2.6.1.2.	Embedded Reference Headers/ITU-R656
20	2.6.1.3.	Embedded Timing Codes (BStream)
20	2.6.2.	Bus Shuffler
20	2.6.3.	Output Multiplexer
20	2.6.4.	Output Ports
21	2.7.	Video Data Transfer
21	2.7.1.	Single and Double Clock Mode
22	2.7.2.	Half Clock Mode
23	2.8.	Video Reference Signals
23	2.8.1.	HREF
23	2.8.2.	VREF
23	2.8.3.	Odd/Even Information (FIELD)
25	2.8.4.	VACT

**Contents, continued**

<b>Page</b>	<b>Section</b>	<b>Title</b>
26	2.9.	Operational Modes
26	2.9.1.	Open Mode
26	2.9.2.	Scan Mode
28	2.10.	Windowing the Video Field
29	2.11.	Temporal Decimation
30	2.12.	Data Slicer
30	2.12.1.	Slicer Features
30	2.12.2.	Data Broadcast Systems
31	2.12.3.	Slicer Functions
31	2.12.3.1.	Input
31	2.12.3.2.	Automatic Adaptation
31	2.12.3.3.	Standard Selection
31	2.12.3.4.	Output
33	2.13.	VBI Data Acquisition
33	2.13.1.	Raw VBI Data
34	2.13.2.	Sliced VBI Data
35	2.14.	Control Interface
35	2.14.1.	Overview
35	2.14.2.	I <sup>2</sup> C-Bus Interface
35	2.14.3.	Reset and I <sup>2</sup> C Device Address Selection
35	2.14.4.	Protocol Description
36	2.14.5.	FP Control and Status Registers
37	2.15.	Initialization of the VPX
37	2.15.1.	Power-on-Reset
37	2.15.2.	Software Reset
37	2.15.3.	Low Power Mode
38	2.16.	JTAG Boundary-Scan, Test Access Port (TAP)
38	2.16.1.	General Description
38	2.16.2.	TAP Architecture
38	2.16.2.1.	TAP Controller
38	2.16.2.2.	Instruction Register
38	2.16.2.3.	Boundary Scan Register
39	2.16.2.4.	Bypass Register
39	2.16.2.5.	Device Identification Register
39	2.16.2.6.	Master Mode Data Register
39	2.16.3.	Exception to IEEE 1149.1
39	2.16.4.	IEEE 1149.1–1990 Spec Adherence
39	2.16.4.1.	Instruction Register
39	2.16.4.2.	Public Instructions
40	2.16.4.3.	Self-Test Operation
40	2.16.4.4.	Test Data Registers
40	2.16.4.5.	Boundary-Scan Register
40	2.16.4.6.	Device Identification Register
40	2.16.4.7.	Performance
44	2.17.	Enable/Disable of Output Signals

**Contents, continued**

<b>Page</b>	<b>Section</b>	<b>Title</b>
<b>45</b>	<b>3.</b>	<b>Specifications</b>
45	3.1.	Outline Dimensions
48	3.2.	Pin Connections and Short Descriptions
45	3.3.	Pin Descriptions
47	3.4.	Pin Configuration
48	3.5.	Pin Circuits
<b>50</b>	<b>4.</b>	<b>Electrical Characteristics</b>
50	4.1.	Absolute Maximum Ratings
51	4.2.	Recommended Operating Conditions
51	4.2.1.	Recommended Analog Video Input Conditions
52	4.2.2.	Recommended I <sup>2</sup> C Conditions
52	4.2.3.	Recommended Digital Inputs Levels of RES, OE, TCK, TMS, TDI
53	4.2.4.	Recommended Crystal Characteristics
54	4.3.	Characteristics
54	4.3.1.	Current Consumption
54	4.3.2.	Characteristics, Reset
54	4.3.3.	XTAL Input Characteristics
55	4.3.4.	Characteristics, Analog Front-End and ADCs
56	4.3.5.	Characteristics, Control Bus Interface
56	4.3.6.	Characteristics, JTAG Interface (Test Access Port TAP)
57	4.3.7.	Characteristics, Digital Inputs/Outputs
57	4.3.8.	Clock Signals PIXCLK, LLC, and LLC2
58	4.3.9.	Digital Video Interface
58	4.3.10.	Characteristics, TTL Output Driver
59	4.3.10.1.	TTL Output Driver Description
<b>60</b>	<b>5.</b>	<b>Timing Diagrams</b>
60	5.1.	Power-up Sequence
60	5.2.	Default Wake-up Selection
61	5.3.	Control Bus Timing Diagram
62	5.4.	Output Enable by Pin $\overline{OE}$
63	5.5.	Timing of the Test Access Port TAP
63	5.6.	Timing of all Pins connected to the Boundary-Scan-Register-Chain
64	5.7.	Timing Diagram of the Digital Video Interface
64	5.7.1.	Characteristics, Clock Signals
<b>65</b>	<b>6.</b>	<b>Control and Status Registers</b>
65	6.1.	Overview
68	6.1.1.	Description of I <sup>2</sup> C Control and Status Registers
72	6.1.2.	Description of FP Control and Status Registers

---

**Contents, continued**

<b>Page</b>	<b>Section</b>	<b>Title</b>
<b>83</b>	<b>7.</b>	<b>Application Notes</b>
83	7.1.	Differences between VPX 3220A and VPX 322xD
83	7.2.	Impact to Signal to Noise Ratio
83	7.3.	Control Interface
83	7.3.1.	Symbols
83	7.3.2.	Write Data into I <sup>2</sup> C Register
83	7.3.3.	Read Data from I <sup>2</sup> C Register
83	7.3.4.	Write Data into FP Register
83	7.3.5.	Read Data from FP Register
84	7.3.6.	Sample Control Code
84	7.4.	Xtal Supplier
85	7.5.	Typical Application
<b>88</b>	<b>8.</b>	<b>Data Sheet History</b>

## Video Pixel Decoder

**Release Note:** This data sheet describes functions and characteristics of VPX 322xD–C3 and D4. Revision bars indicate significant changes to the previous edition.

### 1. Introduction

The Video Pixel Decoders VPX 3225D and VPX 3224D are the second generation of full feature video acquisition ICs for consumer video and multimedia applications. All of the processing necessary to convert an analog video signal into a digital component stream have been integrated onto a single 44-pin IC. Moreover, the VPX 3225D provides text slicing for intercast, teletext, and closed caption. Both chips are pin compatible to VPX 3220A, VPX 3216B, and VPX 3214C. Notable features include:

### Video Decoding

- multistandard color decoding:
  - NTSC-M, NTSC-443
  - PAL-BGHI, PAL-M, PAL-N, PAL-60
  - SECAM
  - S-VHS
- NTSC with Y/C comb filter
- two 8-bit video A/D converters with clamping and automatic gain control (AGC)
- four analog inputs with integrated selector for:
  - 3 composite video sources (CVBS), or
  - 2 Y/C sources (S-VHS), or
  - 2 composite video sources and one Y/C source.
- horizontal and vertical sync detection for all standards
- decodes and detects Macrovision 7.1 protected video (version D4 only)

### Video Processing

- hue, brightness, contrast, and saturation control
- dual window cropping and scaling
- horizontal resizing between 32 and 864 pixels/line
- vertical resizing by line dropping
- high-quality anti-aliasing filter
- scaling controlled peaking and coring

## Video Interfacing

- YC<sub>b</sub>C<sub>r</sub> 4:2:2 format
- ITU-R 601 compliant output format
- ITU-R 656 compliant output format
- BStream compliant output format
- square pixel format (640 or 768 pixel/line)
- 8-bit or 16-bit synchronous output mode
- 13.5 MHz/16-bit and 27 MHz/8-bit output rate
- VBI bypass and raw ADC data output

## Data Broadcast Support (VPX 3225D only)

- high-performance data slicing in hardware
- multistandard data slicer
  - NABTS, WST
  - CAPTION (1x,2x), VPS, WSS, Antiope
- full support for
  - teletext, intercast, wavetop,
  - WebTV for windows, EPG services
- programmable to new standards via I<sup>2</sup>C
- automatic slice level adaptation
- VBI and Full-Field mode
- data insertion into video stream
- simultaneous acquisition of teletext, VPS, WSS, and caption

## Miscellaneous

- 44-pin PLCC package
- total power consumption of below 1 W
- I<sup>2</sup>C serial control, 2 different device addresses
- single on-chip clock generation, only one crystal needed for all standards
- user programmable output pins
- power-down mode
- IEEE 1149.1 (JTAG) boundary scan interface

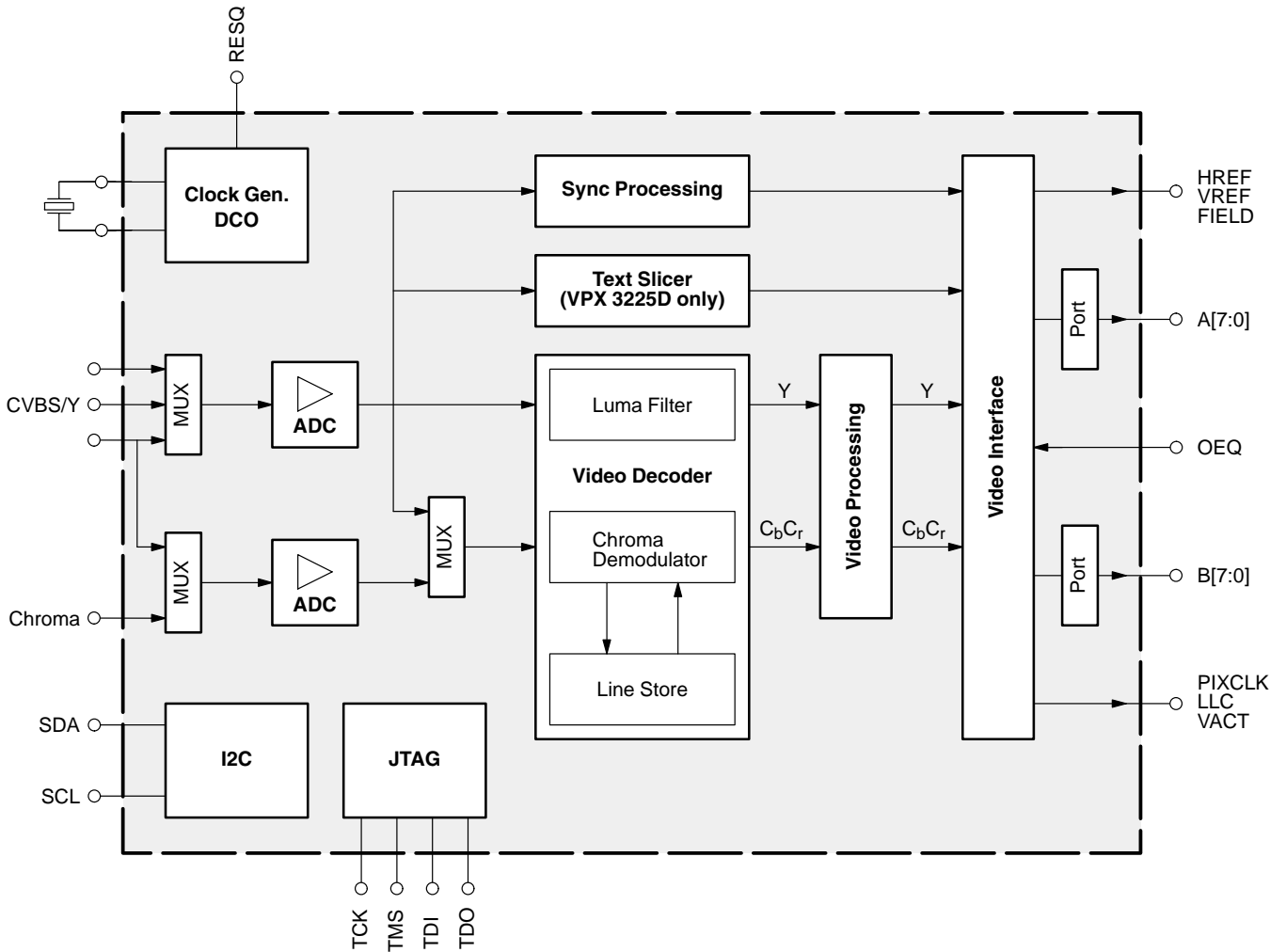
## Software Support

- MediaCVR Software Suite
  - Video for Windows driver
  - TV viewer applet, teletext browser
  - intercast/wavetop browser
- WebTV for Windows
  - Video capture and VBI services

**1.1. System Architecture**

The block diagram (Fig. 1–1) illustrates the signal flow through the VPX. A sampling stage performs 8-bit A/D conversion, clamping, and AGC. The color decoder separates the luma and chroma signals, demodulates the chroma, and filters the luminance. A sync slicer detects the sync edge and computes the skew relative to the sample clock. The video processing stage resizes the YCbCr samples, adjusts the contrast and brightness, and interpolates the chroma. The text slicer extracts lines with text information and delivers decoded data bytes to the video interface.

**Note:** The VPX 3225D and VPX 3224D are not register compatible with the VPX 3220A, VPX 3216B, and VPX 3214C family.



**Fig. 1–1:** Block diagram of the VPX 3224D, VPX 3225D

**2. Functional Description**

The following sections provide an overview of the different functional blocks within the VPX. Most of them are controlled by the Fast Processor ('FP') embedded in the decoder. For controlling, there are two classes of registers: I<sup>2</sup>C registers (directly addressable via I<sup>2</sup>C bus) and FP-RAM registers (ram memory of the FP; indirectly addressable via I<sup>2</sup>C bus). For further information, see section 2.14.1.

**2.1. Analog Front-End**

This block provides the analog interfaces to all video inputs and mainly carries out analog-to-digital conversion for the following digital video processing. A block diagram is given in Fig. 2–1.

Clamping, AGC, and clock DCO are digitally controlled. The control loops are closed by the embedded processor.

**2.1.1. Input Selector**

Up to four analog inputs can be connected. Three inputs (VIN1–3) are for input of composite video or S-VHS luma signal. These inputs are clamped to the sync back porch and are amplified by a variable gain amplifier. Two inputs, one dedicated (CIN) and one shared (VIN1), are for connection of S-VHS carrier-chrominance signal. The chrominance input is internally biased and has a fixed gain amplifier.

**2.1.2. Clamping**

The composite video input signals are AC coupled to the IC. The clamping voltage is stored on the coupling ca-

pacitors and is generated by digitally controlled current sources. The clamping level is the back porch of the video signal. S-VHS chroma is AC coupled. The input pin is internally biased to the center of the ADC input range.

**2.1.3. Automatic Gain Control**

A digitally working automatic gain control adjusts the magnitude of the selected baseband by +6/–4.5 dB in 64 logarithmic steps to the optimal range of the ADC. The gain of the video input stage including the ADC is 213 steps/V with the AGC set to 0 dB.

**2.1.4. Analog-to-Digital Converters**

Two ADCs are provided to digitize the input signals. Each converter runs with 20.25 MHz and has 8-bit resolution. An integrated bandgap circuit generates the required reference voltages for the converters. The two ADCs are of a 2-stage subranging type.

**2.1.5. ADC Range**

The ADC input range for the various input signals and the digital representation is given in Table 2–1 and Fig. 2–2. The corresponding output signal levels of the VPX 32xx are also shown.

**2.1.6. Digitally Controlled Clock Oscillator**

The clock generation is also a part of the analog front end. The crystal oscillator is controlled digitally by the FP; the clock frequency can be adjusted within ±150 ppm.

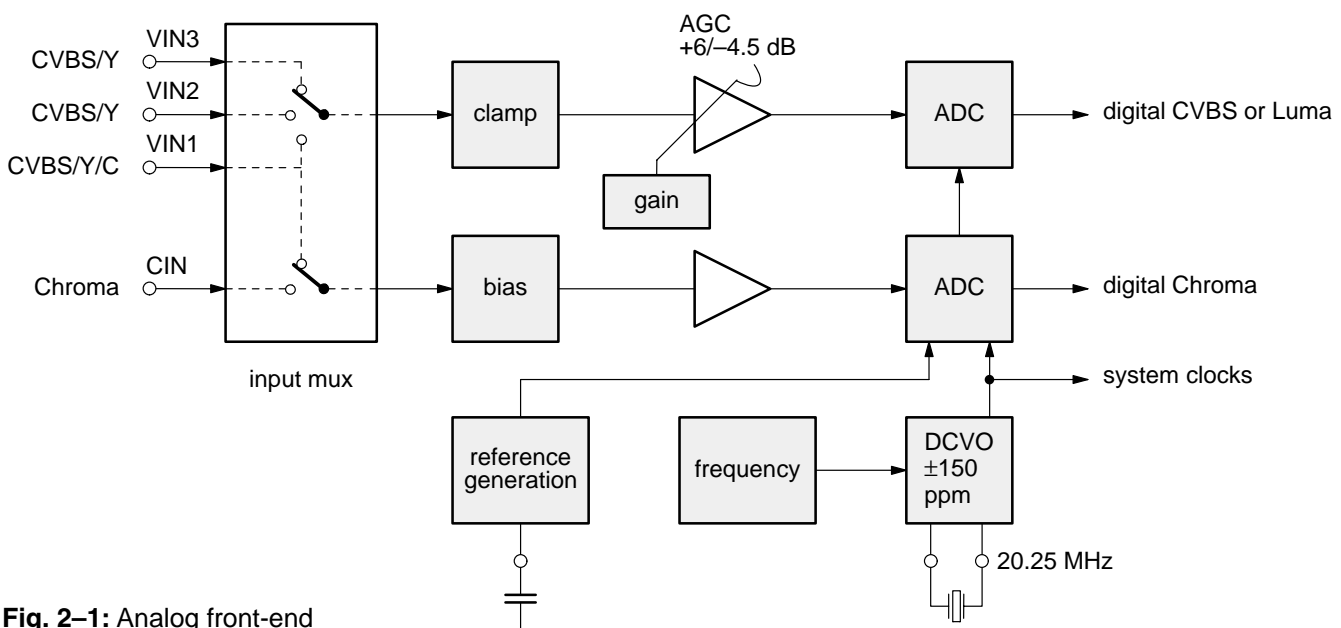
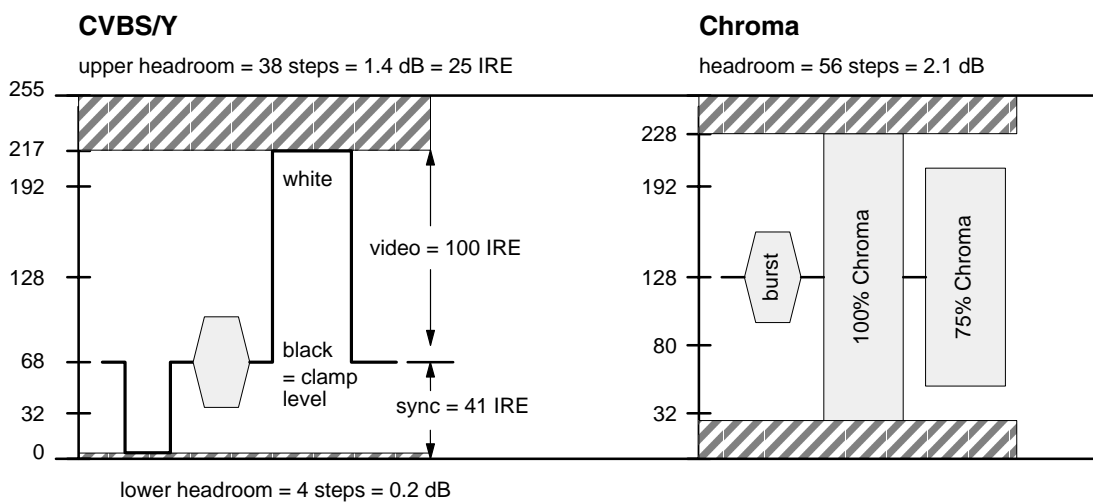


Fig. 2–1: Analog front-end



**Table 2–1:** ADC input range for PAL input signal and corresponding output signal ranges

Signal		Input Level [mV <sub>pp</sub> ]			ADC Range	Y <sub>C</sub> R <sub>C</sub> B <sub>b</sub> Output Range
		–6 dB	0 dB	+4.5 dB		
					[steps]	[steps]
CVBS	100% CVBS	667	1333	2238	252	–
	75% CVBS	500	1000	1679	213	–
	video (luma)	350	700	1175	149	224
	sync height	150	300	504	64	–
	clamp level				68	16
Chroma	burst		300		64	–
	100% Chroma		890		190	128 ± 112
	75% Chroma		670		143	128 ± 84
	bias level				128	128



**Fig. 2–2:** ADC ranges for CVBS/Luma and Chroma, PAL input signal

**2.2. Color Decoder**

In this block, the standard luma/chroma separation and multi-standard color demodulation is carried out. The color demodulation uses an asynchronous clock, thus allowing a unified architecture for all color standards.

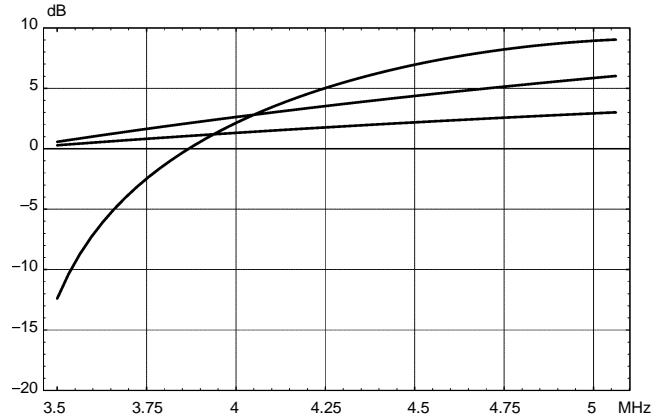
A block diagram of the color decoder is shown in Fig. 2–4. The luma, as well as the chroma processing, is shown here. The color decoder also provides several special modes; for example, wide band chroma format which is intended for S-VHS wide bandwidth chroma. The output of the color decoder is  $Y C_r C_b$  in a 4:2:2 format.

**2.2.1. IF-Compensation**

With off-air or mistuned reception, any attenuation at higher frequencies or asymmetry around the color sub-carrier is compensated. Four different settings of the IF-compensation are possible:

- flat (no compensation)
- 6 dB/octave
- 12 dB/octave
- 10 dB/MHz

The last setting gives a very large boost to high frequencies. It is provided for SECAM signals that are decoded using a SAW filter specified originally for the PAL standard.

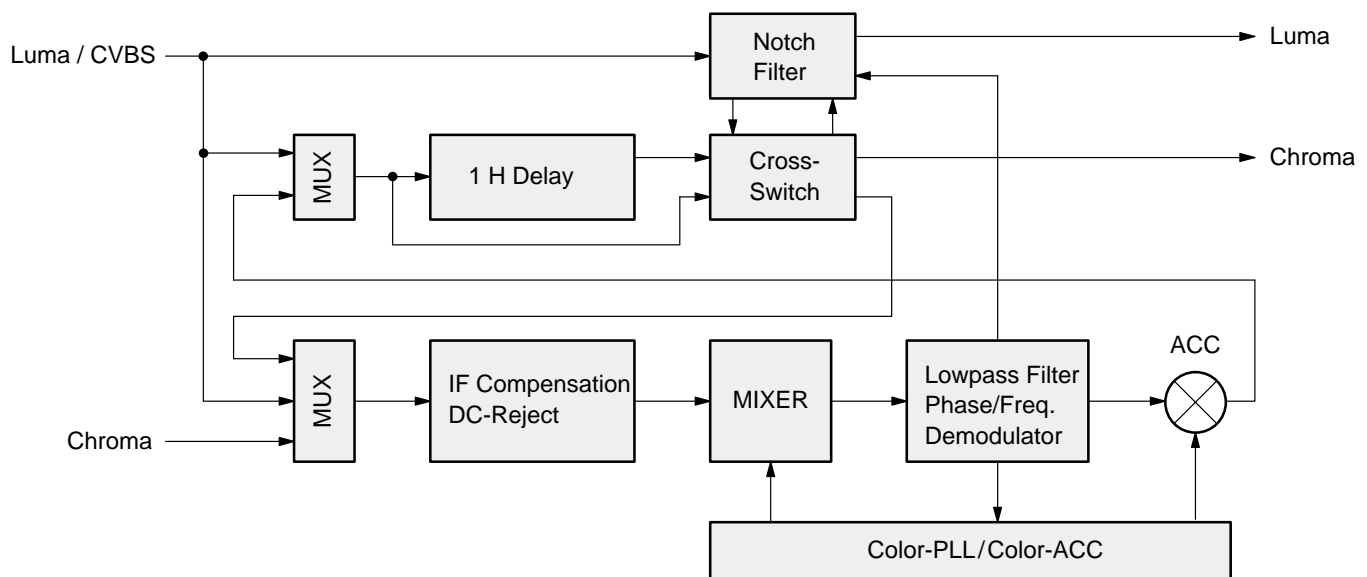


**Fig. 2–3:** Freq. response of chroma IF-compensation

**2.2.2. Demodulator**

The entire signal (which might still contain luma) is now quadrature-mixed to the baseband. The mixing frequency is equal to the subcarrier for PAL and NTSC, thus achieving the chroma demodulation. For SECAM, the mixing frequency is 4.286 MHz giving the quadrature baseband components of the FM modulated chroma. After the mixer, a lowpass filter selects the chroma components; a downsampling stage converts the color difference signals to a multiplexed half rate data stream.

The subcarrier frequency in the demodulator is generated by direct digital synthesis; therefore, substandards such as PAL 3.58 or NTSC 4.43 can also be demodulated.

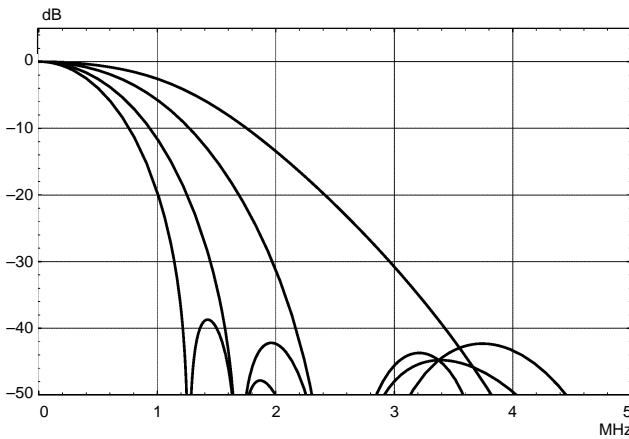


**Fig. 2–4:** Color decoder

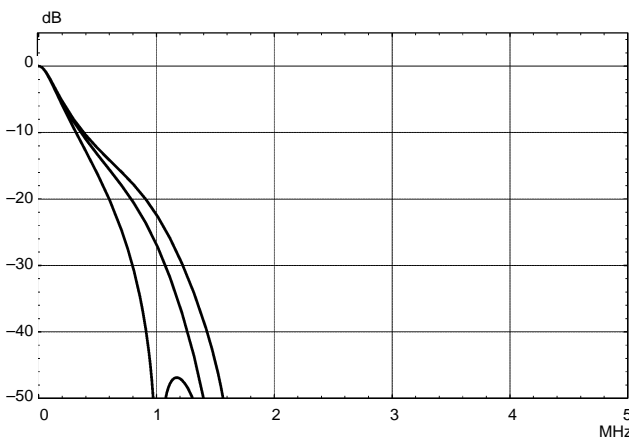
**2.2.3. Chrominance Filter**

The demodulation is followed by a lowpass filter for the color difference signals for PAL/NTSC. SECAM requires a modified lowpass function with bell-filter characteristic. At the output of the lowpass filter, all luma information is eliminated.

The lowpass filters are calculated in time multiplex for the two color signals. Four bandwidth settings (narrow, normal, broad, wide) are available for each standard. The filter passband can be shaped with an extra peaking term at 1.25 MHz. For PAL/NTSC, a wide band chroma filter can be selected. This filter is intended for high bandwidth chroma signals; for example, a nonstandard wide bandwidth S-VHS signal.



PAL/NTSC



SECAM

**Fig. 2-5:** Frequency response of chroma filters

**2.2.4. Frequency Demodulator**

The frequency demodulator for demodulating the SECAM signal is implemented as a CORDIC-structure. It calculates the phase and magnitude of the quadrature components by coordinate rotation.

The phase output of the CORDIC processor is differentiated to obtain the demodulated frequency. After a programmable deemphasis filter, the Dr and Db signals are scaled to standard  $C_r C_b$  amplitudes and fed to the crossover-switch.

**2.2.5. Burst Detection**

In the PAL/NTSC-system, the burst is the reference for the color signal. The phase and magnitude outputs of the CORDIC are gated with the color key and used for controlling the phase-lock-loop (APC) of the demodulator and the automatic color control (ACC) in PAL/NTSC. The ACC has a control range of +30...-6 dB.

For SECAM decoding, the frequency of the burst is measured. Thus, the current chroma carrier frequency can be identified and is used to control the SECAM processing. The burst measurements also control the color killer operation; they can be used for automatic standard detection as well.

**2.2.6. Color Killer Operation**

The color killer uses the burst-phase/burst-frequency measurement to identify a PAL/NTSC or SECAM color signal. For PAL/NTSC, the color is switched off (killed) as long as the color subcarrier PLL is not locked. For SECAM, the killer is controlled by the toggle of the burst frequency. The burst amplitude measurement is used to switch off the color if the burst amplitude is below a programmable threshold. Thus, color will be killed for very noisy signals. The color amplitude killer has a programmable hysteresis.

**2.2.7. PAL Compensation/1-H Comb Filter**

The color decoder uses one fully integrated delay line. Only active video is stored.

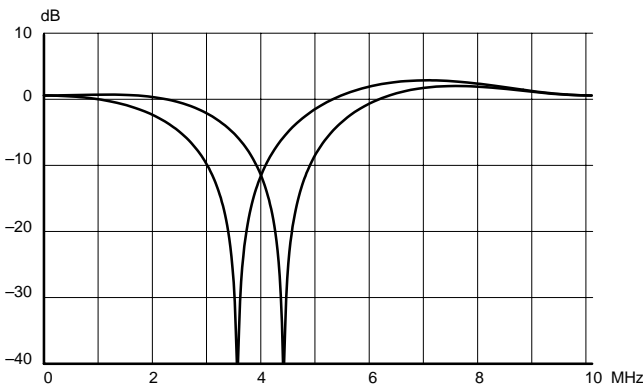
The delay line application depends on the color standard:

- NTSC: 1-H comb filter **or** color compensation
- PAL: color compensation
- SECAM: crossover-switch

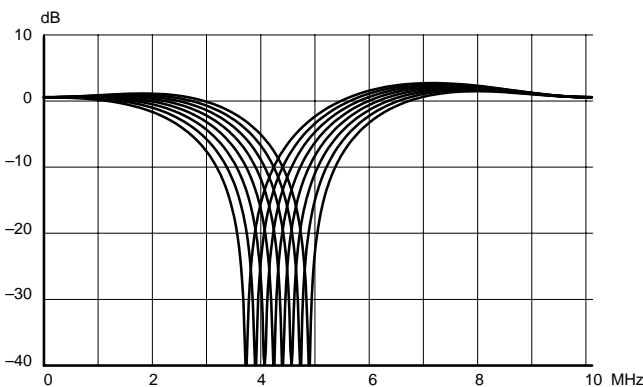
In the NTSC compensated mode, Fig. 2-7 c), the color signal is averaged for two adjacent lines. Thus, cross-color distortion and chroma noise is reduced. In the NTSC combfilter mode, Fig. 2-7 d), the delay line is in the composite signal path, thus allowing reduction of cross-color components, as well as cross-luminance. The loss of vertical resolution in the luminance channel is compensated by adding the vertical detail signal with removed color information.

**2.2.8. Luminance Notch Filter**

If a composite video signal is applied, the color information is suppressed by a programmable notch filter. The position of the filter center frequency depends on the subcarrier frequency for PAL/NTSC. For SECAM, the notch is directly controlled by the chroma carrier frequency. This considerably reduces the cross-luminance. The frequency responses for all three systems are shown in Fig. 2-6. In S-VHS mode, this filter is bypassed.

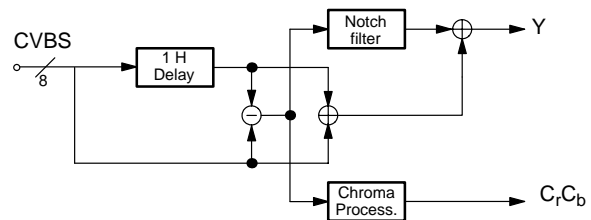
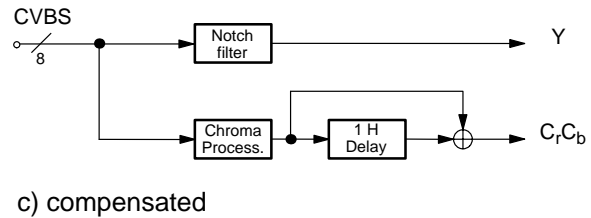
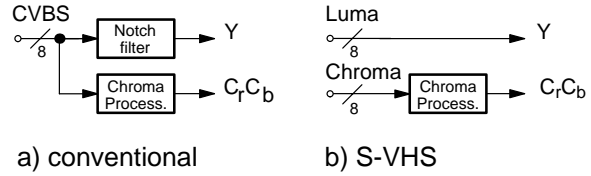


PAL/NTSC notch filter



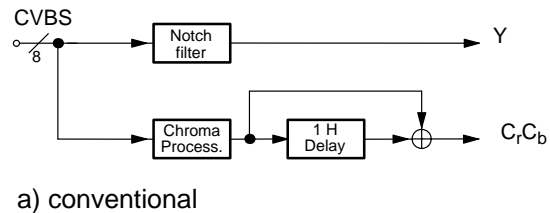
SECAM notch filter

**Fig. 2-6:** Frequency responses of the luma notch filter for PAL, NTSC, SECAM

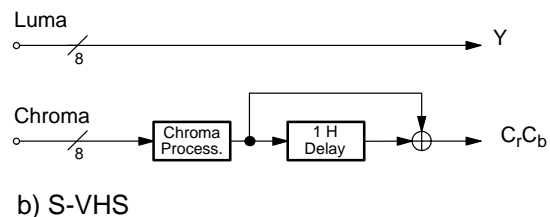


d) comb filter

**Fig. 2-7:** NTSC color decoding options

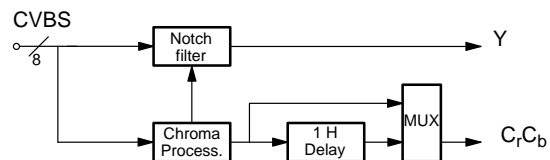


a) conventional



b) S-VHS

**Fig. 2-8:** PAL color decoding options



**Fig. 2-9:** SECAM color decoding

**2.3. Video Sync Processing**

Fig. 2–10 shows a block diagram of the front-end sync processing. To extract the sync information from the video signal, a linear phase lowpass filter eliminates all noise and video contents above 1 MHz. The sync is separated by a slicer; the sync phase is measured. The internal controller can select variable windows to improve the noise immunity of the slicer. The phase comparator measures the falling edge of sync, as well as the integrated sync pulse.

The sync phase error is filtered by a phase-locked loop that is computed by the FP. All timing in the front-end is derived from a counter that is part of this PLL, and it thus counts synchronously to the video signal.

A separate hardware block measures the signal back porch and also allows gathering the maximum/minimum of the video signal. This information is processed by the FP and used for gain control and clamping.

For vertical sync separation, the sliced video signal is integrated. The FP uses the integrator value to derive vertical sync and field information.

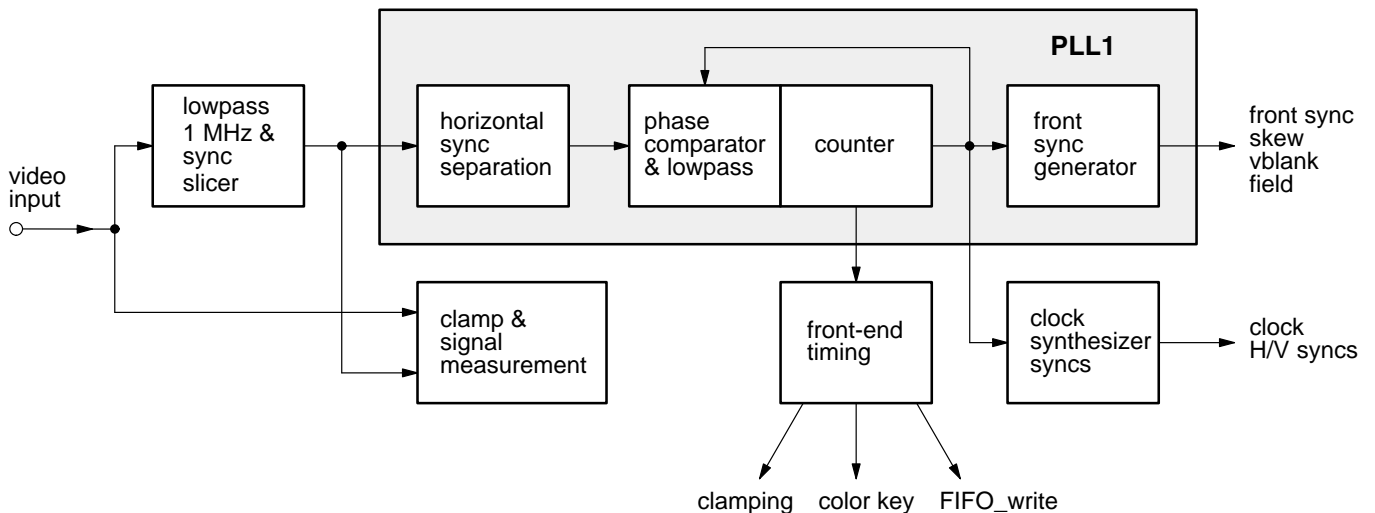
Frequency and phase characteristics of the analog video signal are derived from PLL1. The results are fed to the rest of the video processing system in the backend. The resizer unit uses them for data interpolation and orthogonalization. A separate timing block derives the timing reference signals HREF and VREF from the horizontal sync.

**2.4. Macrovision Detection (version D4 only)**

Video signals from Macrovision encoded VCR tapes are decoded without loss of picture quality. However, it might be necessary in some applications to detect the presence of Macrovision encoded video signals. This is possible by reading a set of I<sup>2</sup>C registers (FP-RAM 0x170–0x179) in the video front-end.

Macrovision encoded video signals typically have AGC pulses and pseudo sync pulses added during VBI. The amplitude of the AGC pulses is modulated in time. The Macrovision detection logic measures the VBI lines and compares the signal against programmable thresholds.

The window in which the video lines are checked for Macrovision pulses can be defined in terms of start and stop line (e.g. 6–15 for NTSC).



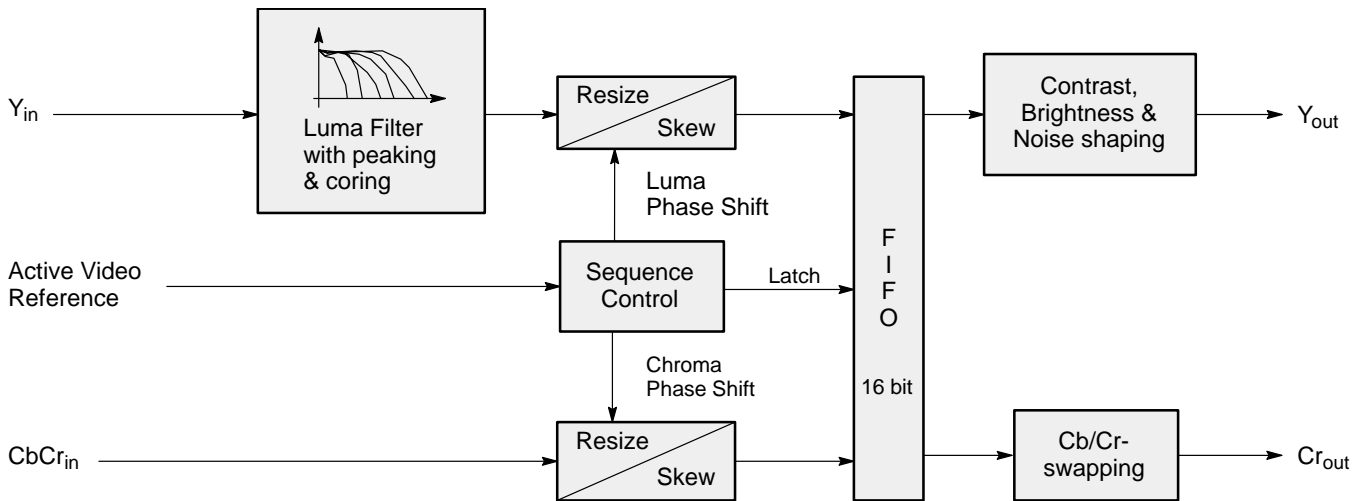
**Fig. 2–10:** Sync separation block diagram

**2.5. Component Processing**

Recovery of the YCbCr components by the decoder is followed by horizontal resizing and skew compensation. Contrast enhancement with noise shaping can also be applied to the luminance signal. Vertical resizing is supported via line dropping.

Fig. 2–11 illustrates the signal flow through the component processing stage. The YCbCr 4:2:2 samples are separated into a luminance path and a chrominance path.

The Luma Filtering block applies anti-aliasing low-pass filters with cutoff frequencies adapted to the number of samples after scaling, as well as peaking and coring. The Resize and Skew blocks alter the effective sampling rate and compensate for horizontal line skew. The YCbCr samples are buffered in a FIFO for continuous burst at a fixed clock rate. For luminance samples, the contrast and brightness can be adjusted and noise shaping applied. In the chrominance path, Cb and Cr samples can be swapped. Without swapping, the first valid video sample is a Cb sample. Chrominance gain can be adjusted in the color decoder.



**Fig. 2–11:** Component processing stage

**Table 2–2:** Several rasters supported by the resizer

NTSC	PAL/SECAM	Format Name
640 x 480	768 x 576	Square pixels for broadcast TV (4:3)
704 x 480	704 x 576	Input Raster for MPEG-2
320 x 240	384 x 288	Square pixels for TV (quarter resolution)
352 x 240	352 x 288	CIF – Input raster for MPEG-1, H.261
160 x 120	192 x 144	Square pixels for TV (1/16 resolution), H.324, H.323
176 x 120	176 x 144	QCIF – Input raster for H.261
32 x 24	32 x 24	Video icons for graphical interfaces (square)

### 2.5.1. Horizontal Resizer

The operating range of the horizontal resizer was chosen to serve the widest possible range of applications and source formats (number of lines, aspect ratio, etc...). Table 2-2 lists several examples for video sourced from 525/625 line TV systems.

The horizontal resizer alters the sampling raster of the video signal, thereby varying the number of pixels (NPix) in the active portion of the video line. The number of pixels per line is selectable within a range from 32 to 864 in increments of 2 pixels (see section 2.10.: Windowing the Video Field). Table 2-2 gives an overview of several supported video rasters. The visual quality of a sampling rate conversion operation depends on two factors:

- the frequency response of the individual filters, and
- the number of available filters from which to choose.

The VPX is equipped with a battery of FIR filters to cover the five octave operating range of the resizer. Fig. 2-12 shows the magnitude response of five example filters corresponding to 1054, 526, 262, 130, and 32 pixels.

The density of the filter array can be seen in Fig. 2-13. The magnitude response of 50 filters lying next to each other are shown. Nevertheless, these are only 10% of all filters shown. As a whole, the VPX comes with a battery of 512 FIR filters. Showing these 512 Filters in Fig. 2-12 would result in a large black area. This dense array of filters is necessary in order to maintain constant visual quality over the range of allowable picture sizes. The alternative would be to use a small number of filters whose cutoff frequencies are regularly spaced over the spectrum. However, it has been found that using few filters leads to visually annoying threshold behavior. These effects occur when the filters are changed in response to variations in the picture size.

Filter selection is performed automatically by the internal processor based on the selected resizing factor (NPix). This automated selection is optimized for best visual performance.

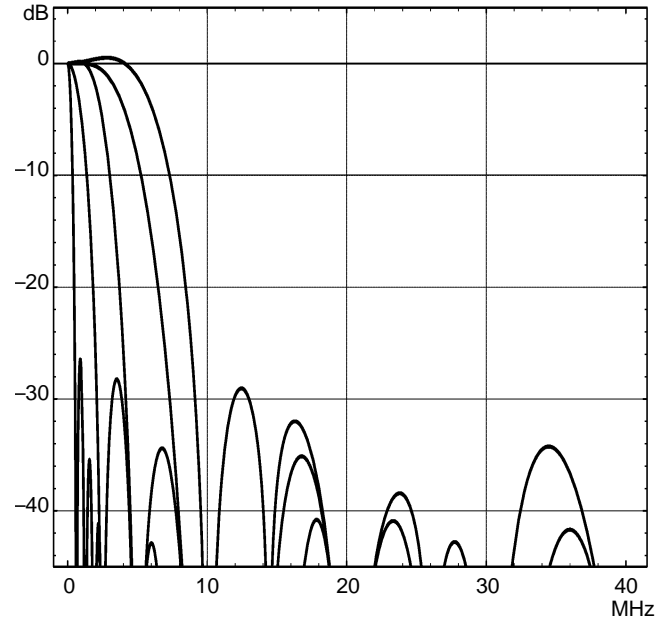


Fig. 2-12: Freq. response of 5 widely spaced filters

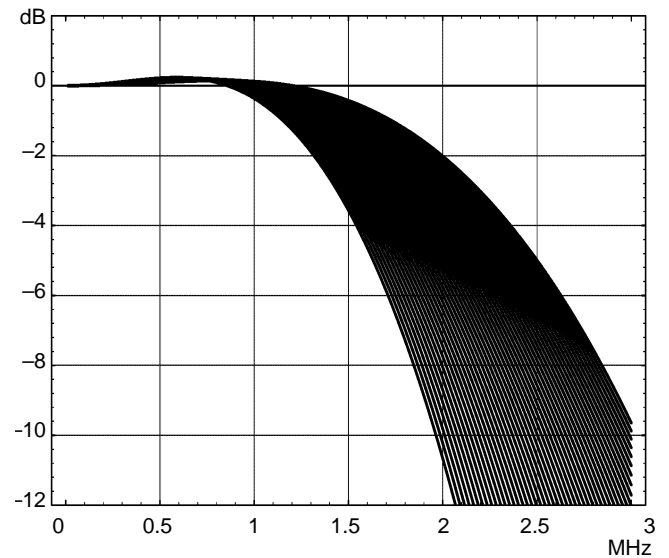


Fig. 2-13: Freq. response of 50 neighbored filters

**2.5.2. Skew Correction**

The VPX delivers orthogonal pixels with a fixed clock even in the case of non-broadcast signals with substantial horizontal jitter (VCRs, laser disks, certain portions of the 6 o'clock news...).

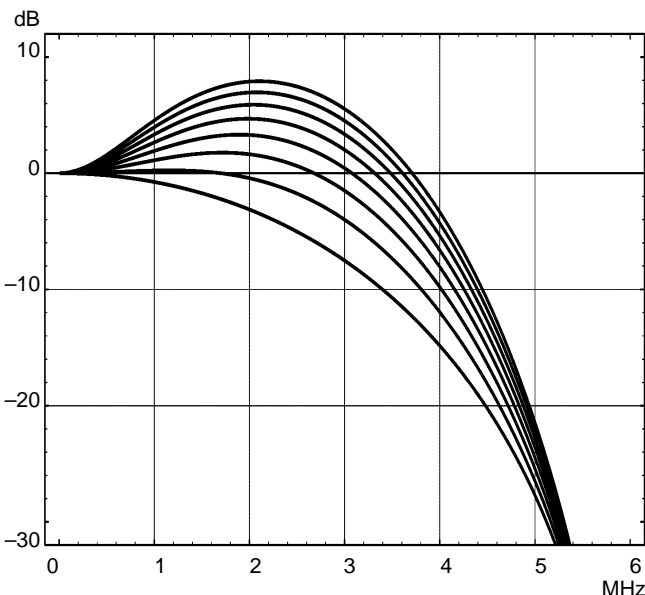
This is achieved by highly accurate sync slicing combined with post correction. Immediately after the analog input is sampled, a horizontal sync slicer tracks the position of sync. This slicer evaluates, to within 1.6 ns, the skew between the sync edge and the edge of the pixel-clock. This value is passed as a skew on to the phase shift filter in the resizer. The skew is then treated as a fixed initial offset during the resizing operation.

The skew block in the resizer performs programmable phase shifting with subpixel accuracy. In the luminance path, a linear interpolation filter provides a phase shift between 0 and 31/32 in steps of 1/32. This corresponds to an accuracy of 1.6 ns. The chrominance signal can be shifted between 0 and 7/8 in steps of 1/8.

**2.5.3. Peaking and Coring**

The horizontal resizer comes with an extra peaking filter for sharpness control. The center frequency of the peaking filter is automatically adjusted to the image size in 512 steps. The peaking value to each center frequency can be controlled by the user with up to eight steps via FP-RAM 0x126/130. Fig. 2-14 shows the magnitude response of the eight steps of the peaking filter corresponding to an image size of 320 pixels.

After the peaking filter, an additional coring filter is implemented to the horizontal resizer. The coring filter subtracts 0, 1/2, 1, or 2 LSBs of the higher frequency part of the signal. Note, that coring can be performed independently of the peaking value adjustment.



**Fig. 2-14:** Frequency response of peaking filter

**2.5.4. YCbCr Color Space**

The color decoder outputs luminance and one multiplexed chrominance signal at a sample clock of 20.25 MHz. Active video samples are flagged by a separate reference signal. Internally, the number of active samples is 1080 for all standards (525 lines and 625 lines). The representation of the chroma signals is the ITU-R 601 digital studio standard.

In the color decoder, the weighting for both color difference signals is adjusted individually. The default format has the following specification:

- $Y = 224 * Y + 16$  (pure binary),
- $C_r = 224 * (0.713 * (R - Y)) + 128$  (offset binary),
- $C_b = 224 * (0.564 * (B - Y)) + 128$  (offset binary).

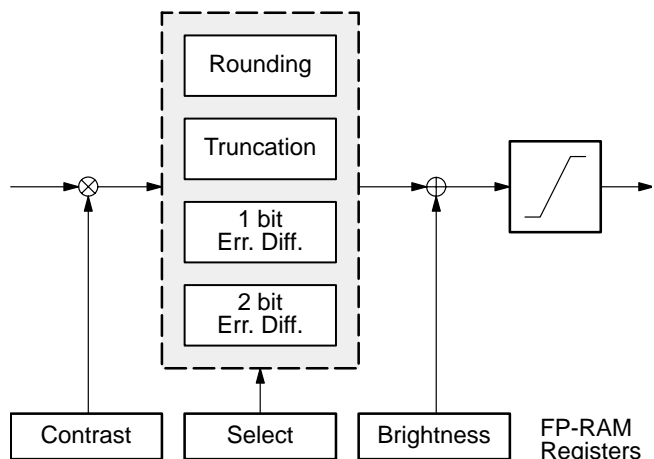
**2.5.5. Video Adjustments**

The VPX provides a selectable gain (contrast) and offset (brightness) for the luminance samples, as well as additional noise shaping. Both the contrast and brightness factors can be set externally via I<sup>2</sup>C serial control of FP-RAM 0x127,128,131, and 132. Fig. 2-15 gives a functional description of this circuit. First, a gain is applied, yielding a 10-bit luminance value. The conversion back to 8-bit is done using one of four selectable techniques: simple rounding, truncation, 1-bit error diffusion, or 2-bit error diffusion. Bit[8] in the 'contrast'-register selects between the clamping levels 16 and 32.

$$I_{out} = c * I_{in} + b$$

$c = 0...63/32$  in 64 steps  
 $b = -127...128$  in 256 steps

In the chrominance path, Cb and Cr samples can be swapped with bit[8] in FP-RAM 0x126 or 130. Adjustment of color saturation and gain is provided via FP-RAM 0x30-33 (see section 2.2.5.).



**Fig. 2-15:** Contrast and brightness adjustment



## 2.6. Video Output Interface

Contrary to the component processing stage running at a clock rate of 20.25 MHz, the output formatting stage (Fig. 2–16) receives the video samples at a pixel transport rate of 13.5 MHz. It supports 8 or 16-bit video formats with separate or embedded reference signals, provides bus shuffling, and channels the output via one or both 8-bit ports. Data transfer is synchronous to the internally generated 13.5 MHz pixel clock.

The format of the output data depends on three parameters:

- the selected output format
  - YUV 4:2:2, separate syncs
  - YUV 4:2:2, ITU-R656
  - YUV 4:2:2, embedded reference codes (BStream)

– the number of active ports (A only, or both A and B)

– clock speed (single, double, half).

In 8-bit modes using only Port A for video data, Port B can be used as programmable output.

### 2.6.1. Output Formats

The VPX supports the YUV 4:2:2 video format only. During normal operation, all reference signals are output separately. To provide a reduced video interface, the VPX offers two possibilities for encoding timing references into the video data stream: an ITU-R656 compliant output format with embedded timing reference headers and a second format with single timing control codes in the video stream. The active output format can be selected via FP-RAM 0x150 [format].

#### 2.6.1.1. YUV 4:2:2 with Separate Syncs/ITU-R601

The default output format of the VPX is a synchronous 16-bit YUV 4:2:2 data stream with separate reference signals. Port A is used for luminance and Port B for chrominance-information. Video data is compliant to ITU-R601. Bit[1:0] of FP-RAM 0x150 has to be set to 00. Figure 2–17 shows the timing of the data ports and the reference signals in this mode.

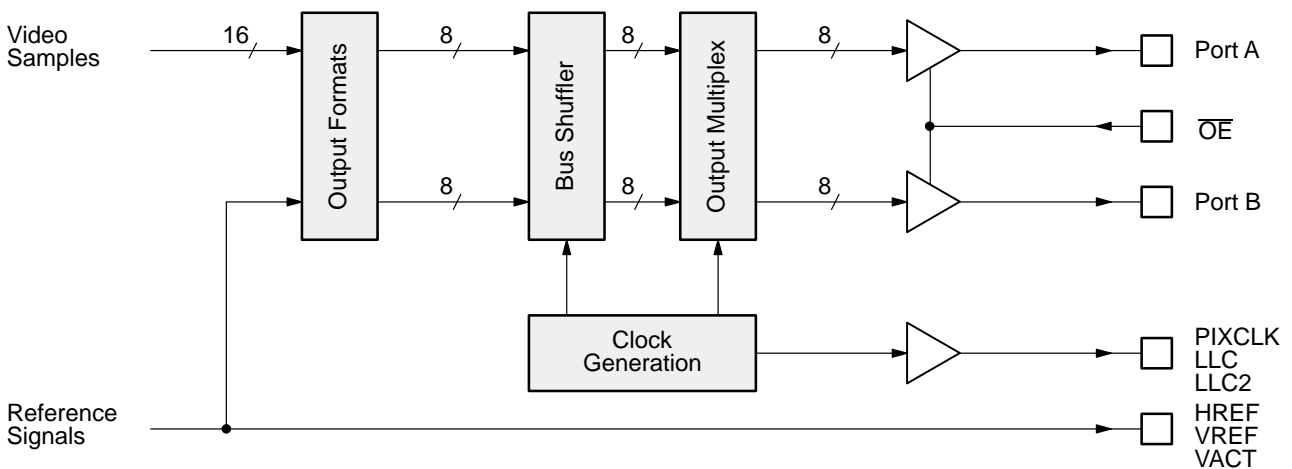


Fig. 2–16: Output format stage

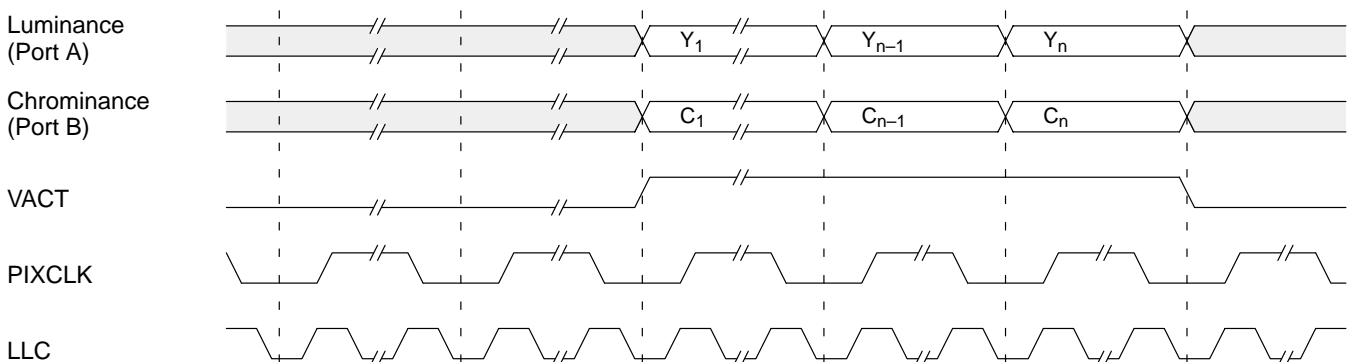


Fig. 2–17: Detailed data output (single clock mode)

**2.6.1.2. Embedded Reference Headers/ITU-R656**

The VPX supports an output format which is designed to be compliant with the ITU-R656 recommendation. It is activated by setting Bit[1:0] of FP-RAM 0x150 to 01. The 16-bit video data must be multiplexed to 8 bit at the double clock frequency (27 MHz) via FP-RAM 0x154, bit 9 set to 1 (see also section 2.6.3.: Output Multiplexer).

In this mode, video samples are in the following order: **Cb, Y, Cr, Y, ...** The data words 0 and 255 are protected since they are used for identification of reference headers. This is assured by limitation of the video data. Timing reference codes are inserted into the data stream at the beginning and the end of each video line in the following way: A 'Start of active video'-Header (SAV) is inserted before the first active video sample. The 'end of active video'-code (EAV) is inserted after the last active video sample. They both contain information about the field type and field blanking. The data words occurring during the horizontal blanking interval between EAV and SAV are filled with 0x10 for luminance and 0x80 for chrominance information. Table 2–3 shows the format of the SAV and EAV header.

Note that the following changes and extensions to the ITU-R656 standard have been included to support horizontal and vertical scaling, transmission of VBI-data, etc.:

- Both the length and the number of active video lines varies with the selected window parameters. For compliance with the ITU-R656 recommendation, a size of 720 samples per line must be selected for each window. To enable a constant line length even in the case of different scaling values for the video windows, the VPX provides a programmable 'active video' signal (see section 2.8.4.).
- During blanked lines, the VACT signal is suppressed. VBI-lines can be marked as blanked or active, thus allowing the choice of enabled or suppressed VACT during the VBI-window. The vertical field blanking flag (V) in the SAV/EAV header is set to zero in any line with enabled VACT signal (valid VBI or video lines).
- During blanked lines, SAV/EAV headers can be suppressed in pairs with FP-RAM 0x150, bit9. To assure vertical sync detection, some SAV/EAV headers are inserted during field blanking.
- The flags F, V, and H encoded in the SAV/EAV headers change on SAV. With FP-RAM 0x150, bit10 set to 1, they change on EAV. The programmed windows, however, are delayed by one line. Header suppression is applied for EAV/SAV pairs.
- For data within the VBI-window (e.g. sliced or raw teletext data), the user can select between limitation or reduction to 7-bit resolution with an additional LSB assuring odd parity (0 and 255 never occur). This option can be selected via FP-RAM 0x150 [range].

- Ancillary data blocks may be longer than 255 bytes (for raw data) and are transmitted without checksum. The secondary data ID is used as high byte of the data count (DC1; see Table 2–5).
- Ancillary data packets must not follow immediately after EAV or SAV.
- The total number of clock cycles per line, as well as valid cycles between EAV and SAV may vary.

**Table 2–3: Coding of the SAV/EAV-header**

Word	Bit No.								
	MSB	7	6	5	4	3	2	1	LSB
First	1	1	1	1	1	1	1	1	1
Second	0	0	0	0	0	0	0	0	0
Third	0	0	0	0	0	0	0	0	0
Fourth	1	F	V	H	P3	P2	P1	P0	

F = 0 during field 1, F = 1 during field 2  
 V = 0 during active lines V = 1 during vertical field blanking  
 H = 0 in SAV, H = 1 in EAV

The bits P0, P1, P2, and P3 are protection bits. Their states are dependent on the states of F, V, and H as shown in Table 2–4.

**Table 2–4: Coding of the protection bits**

Code (hex)	Bit No.							
	MSB	F	V	H	P3	P2	P1	LSB
80	1	0	0	0	0	0	0	0
9D	1	0	0	1	1	1	0	1
AB	1	0	1	0	1	0	1	1
B6	1	0	1	1	0	1	1	0
C7	1	1	0	0	0	1	1	1
DA	1	1	0	1	1	0	1	0
EC	1	1	1	0	1	1	0	0
F1	1	1	1	1	0	0	0	1

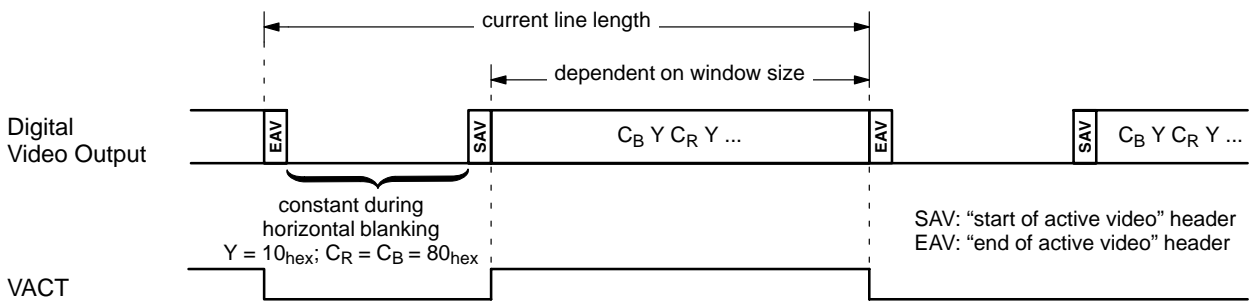
The VPX also supports the transmission of VBI-data as vertical ancillary data during blanked lines in the interval starting with the end of the SAV and terminating with the beginning of EAV. In this case, an additional header is inserted directly before the valid active data. In this mode, the position of SAV and EAV depends on the settings for the programmable VACT signal. These parameters will

be checked and corrected if necessary to assure an appropriate size of VACT for both data and ancillary header.

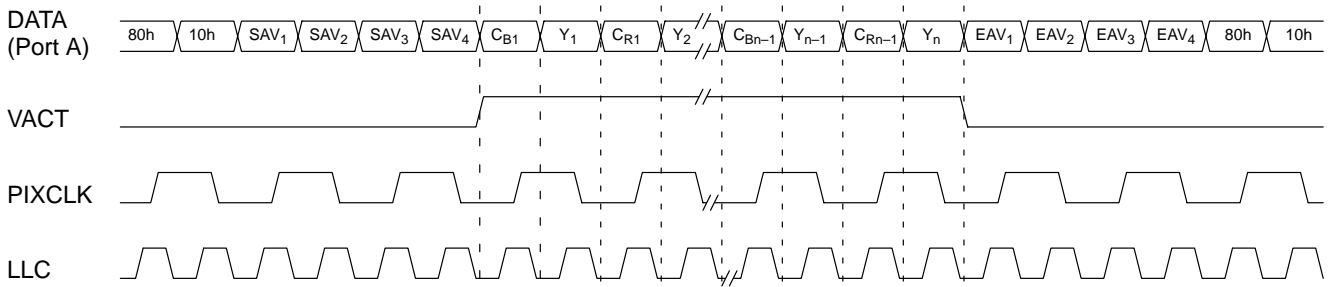
Table 2–5 shows the coding of the ancillary header information. The word I[2:0] contains a value for data type identification (1 for sliced and 3 for raw data during odd fields, 5 for sliced and 7 for raw data during even fields). M[5:0] contains the MSBs and L[5:0] the LSBs of the number of following D-words (32 for sliced data, 285 for raw data). DC1 is normally used as secondary data ID. The value 0 for M[5:0] in the case of sliced data marks an undefined format. Bit 6 is even parity for bit5 to bit0. Bit 7 is the inverted parity flag. Note that the following user data words (video data) are either limited or have odd parity to assure that 0 and 255 will not occur. Bit 3 in RAM 0x150 selects between these two options.

**Table 2–5:** Coding of the ancillary header information

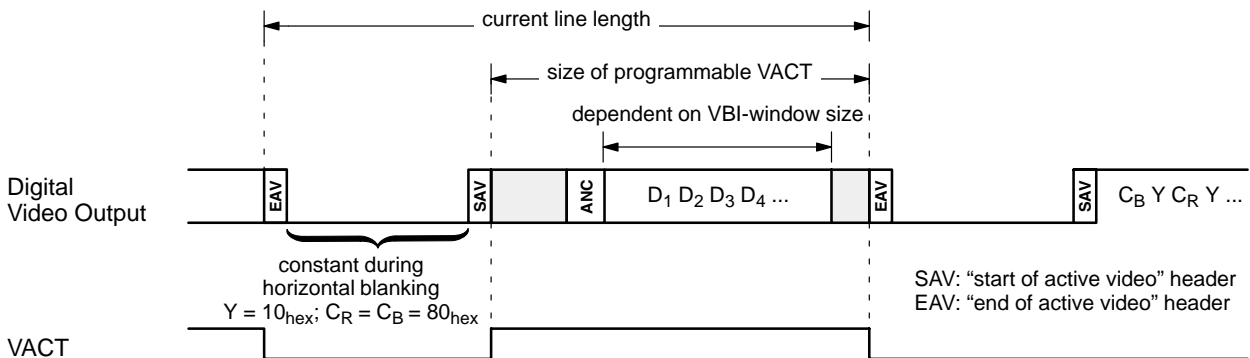
Word	Bit No.							
	7	6	5	4	3	2	1	0
Pream1	0	0	0	0	0	0	0	0
Pream2	1	1	1	1	1	1	1	1
Pream3	1	1	1	1	1	1	1	1
DID	NP	P	0	1	0	I2	I1	I0
DC1	NP	P	M5	M4	M3	M2	M1	M0
DC2	NP	P	L5	L4	L3	L2	L1	L0



**Fig. 2–18:** Output of video or VBI data with embedded reference headers (according to ITU-R656)



**Fig. 2–19:** Detailed data output (double clock mode)



**Fig. 2–20:** Output of VBI-data as ancillary data

**2.6.1.3. Embedded Timing Codes (BStream)**

In this mode, several event words are inserted into the pixel stream for timing information. It is activated by setting Bit[1:0] of FP-RAM 0x150 to 10. Each event word consists of a chrominance code value containing the phase of the color-multiplex followed by a luminance code value signalling a specific event. The allowed control codes are listed in table 2–6 and 2–7.

At the beginning and the end of each active video line, timing reference codes (start of active video: SAV; end of active video: EAV) are inserted with the beginning and the end of VACT. Since VACT is suppressed during blanked lines, video data and SAV/EAV codes are present during active lines only. If raw/sliced data should be output, VACT has to be enabled during the VBI window with bit 2 of FP-RAM 0x138! In the case of several windows per field, the length of the active data stream per line can vary. Since the qualifiers for active video (SAV/EAV) are independent of the other reference codes, there is no influence on horizontal or vertical syncs, and sync generation can be performed even with several different windows. For full compliance with applications requiring data streams of a constant size, the VPX provides a mode with programmable ‘video active’ signal VACT which can be selected via bit 2 of FP-RAM 0x140. The start and end positions of VACT relative to HREF is determined by FP-RAM 0x151 and 0x152. The delay of valid data relative to the leading edge of HREF is calculated with the formulas given in table 2–8 and 2–9. The result can be read in FP-RAM 0x10f (for window 1) and 0x11f (for window 2). Be aware that the largest window defines the size of the needed memory. In the case of 1140 raw VBI-samples and only 32 scaled video samples, the graphics controller needs 570 words for each line (the VBI-samples are multiplexed to luminance and chrominance paths).

The leading edge of HREF indicates the beginning of a new video line. Depending on the type of the current line (active or blanked), the corresponding horizontal reference code is inserted. For big window sizes, the leading edge of HREF can arrive before the end of the active data. In this case, hardware assures that the control code for HREF is delayed and inserted after EAV only. The VREF control code is inserted at the falling edge of VREF. The state of HREF at this moment indicates the current field type (HREF = 0: odd field; HREF = 1: even field).

In this mode, the words 0,1,254, and 255 are reserved for data identifications. This is assured by limitation of the video data.

**Table 2–6:** Chrominance control codes

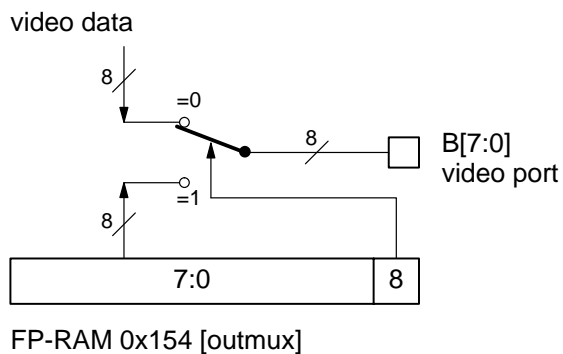
Chroma Value	Phase Information
FE	Cr pixel
FF	Cb pixel

**2.6.2. Bus Shuffler**

In the YUV 4:2:2 mode, the output of luminance data is on port A and chrominance data on Port B. With the bus shuffler, luminance can be switched to Port B and chrominance to port A. In 8-bit double clock mode, shuffling can be used to swap the Y and C components. It is selected with FP-RAM 0x150.

**2.6.3. Output Multiplexer**

During normal operation, a 16-bit YUV 4:2:2 data stream is transferred synchronous to an internally generated PIXCLK at a rate of 13.5 MHz. Data can be latched onto the falling edge of PIXCLK or onto the rising edge of LLC during high PIXCLK. In the double clock mode, luminance and chrominance data are multiplexed to 8 bit and transferred at the double clock frequency of 27 MHz in the order Cb, Y, Cr, Y...; the first valid chrominance value being a Cb sample. With shuffling switched on, Y and C components are swapped. Data can be latched with the rising edge of LLC or alternating edges of PIXCLK. This mode is selected with bit 9 of FP-RAM 0x154. All 8-bit modes use Port A only. In this case, Port B can be activated as programmable output with bit 8 of FP-RAM 0x154. Bit 0–7 determine the state of Port B.



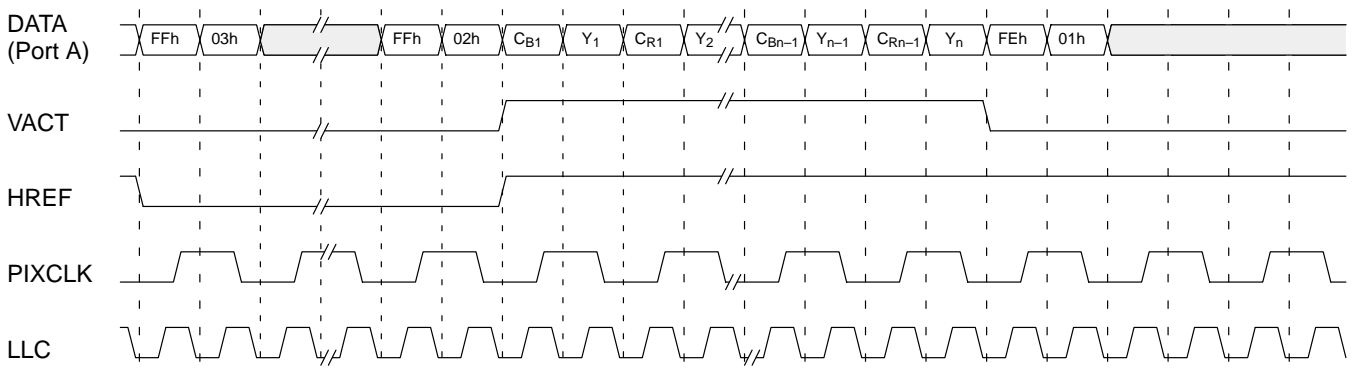
**Fig. 2–21:** Programmable output port

**2.6.4. Output Ports**

The two 8-bit ports produce TTL level signals coded in binary offset. The Ports can be tristated either via the output enable pin (OE) or via I<sup>2</sup>C register 0xF2. For more information, see section 2.17. “Enable/Disable of Output Signals”.

**Table 2–7:** Luminance control codes

Luma Value	Video Event	Video Event	Phase Information
01	VACT end	last pixel was the last active pixel	refers to the last pixel
02	VACT begin	next pixel is the first active pixel	refers to the next pixel
03	HREF active line	begin of an active video line	refers to the current pixel
04	HREF blank line	begin of a blank line	refers to the current pixel
05	VREF even	begin of an even field	refers to the current pixel
06	VREF odd	begin of an odd field	refers to the current pixel



**Fig. 2–22:** Detailed data output with timing event codes (double clock mode)

## 2.7. Video Data Transfer

The VPX supports a synchronous video interface. Video data arrives to each line at the output in an uninterrupted burst with a fixed transport rate of 13.5 MHz. The duration of the burst is measured in clock periods of the transport clock and is equal to the number of pixels per output line.

The data transfer is controlled via the signals: PIXCLK, VACT, and LLC. An additional clock signal LLC2 can be switched to the TDO output pin to support different timings.

The VACT signal flags the presence of valid output data. Fig. 2–23, 2–24, and 2–25 illustrate the relationship between the video port data, VACT, PIXCLK, and LLC. Whenever a line of video data should be suppressed (line dropping, switching between analog inputs), it is done by suppression of VACT.

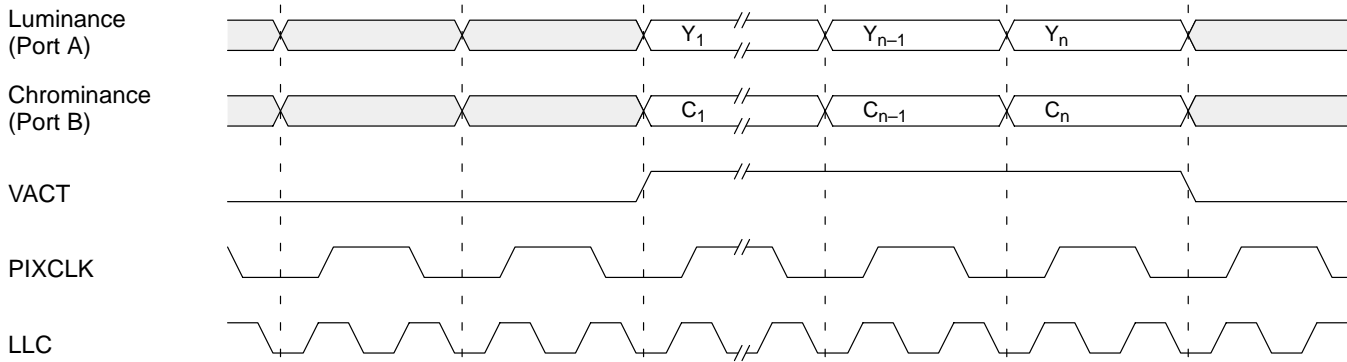
### 2.7.1. Single and Double Clock Mode

Data is transferred synchronous to the internally generated PIXCLK. The frequency of PIXCLK is 13.5 MHz. The LLC signal is provided as an additional support for both the 13.5 MHz and the 27 MHz double clock mode. The LLC consists of a doubled PIXCLK signal (27 MHz) for interface to external components which rely on the Philips transfer protocols. In the single clock mode, data can be latched onto the falling edge of PIXCLK or at the rising edge of LLC during high PIXCLK. In double clock mode, output data can be latched onto both clock edges of PIXCLK or onto every rising edge of LLC. Combined with the half-clock mode, the available transfer bandwidths at the ports are therefore 6.75 MHz, 13.5 MHz, and 27.0 MHz.

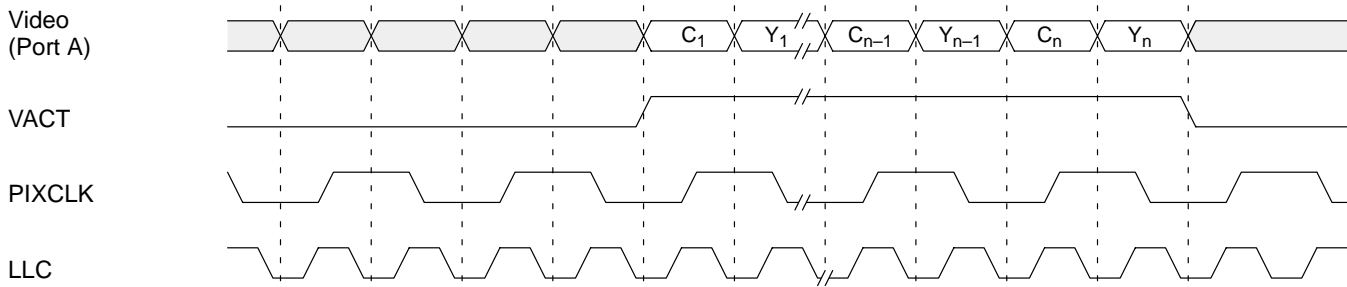
**2.7.2. Half Clock Mode**

For applications demanding a low bandwidth for the transmission between video decoder and graphics controller, the clock signal qualifying the output pixels (PIXCLK) can be divided by 2. This mode is enabled by setting Bit 5 of the FP-RAM 0x150 [halfclk]. Note that the output format ITU-R601 must be selected. The timing of the data and clock signals in this case is described in Figure 2–25.

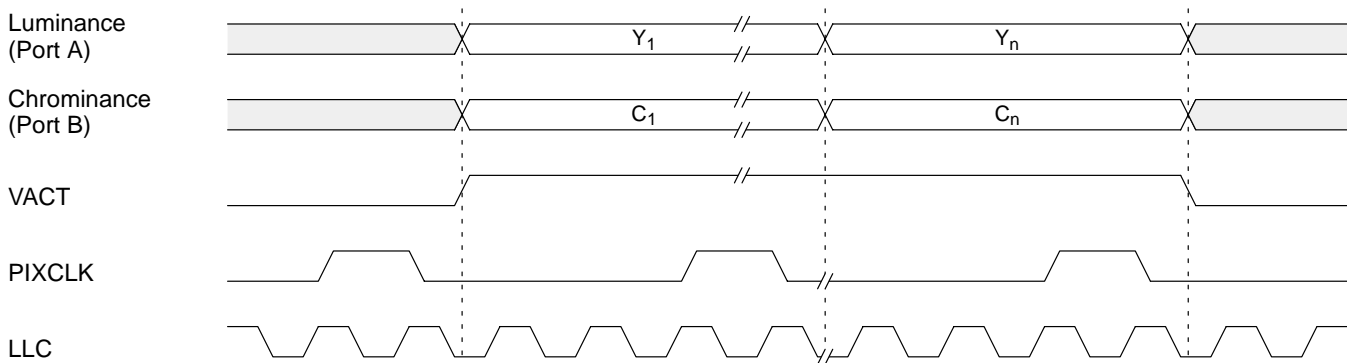
If the half-clock mode is enabled, each second pulse of PIXCLK is gated. PIXCLK can be used as a qualifier for valid data. To ensure that the video data stream can be spread, the selected number of valid output samples should not exceed 400.



**Fig. 2–23:** Output timing in single clock mode



**Fig. 2–24:** Output timing in double clock mode



**Fig. 2–25:** Output timing in half clock mode

**2.8. Video Reference Signals**

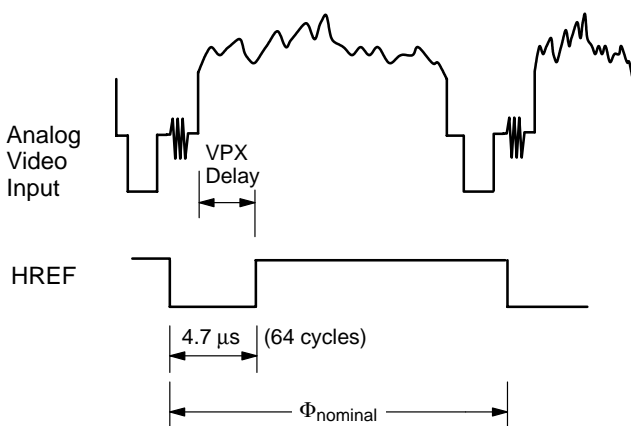
The complete video interface of the VPX runs at a clock rate of 13.5 MHz. It mainly generates two reference signals for the video timing: a horizontal reference (HREF) and a vertical reference (VREF). These two signals are generated by programmable hardware and can be either free running or synchronous to the analog input video. The video line standard (625/50 or 525/60) depends on the TV-standard selected with FP-RAM 0x20 [sdt]. The polarity of both signals is individually selectable via FP-RAM 0x153.

The circuitry which produces the VREF and HREF signals has been designed to provide a stable, robust set of timing signals, even in the case of erratic behavior at the analog video input. Depending on the selected operating mode given in FP-RAM 0x140 [settm], the period of the HREF and VREF signals are guaranteed to remain within a fixed range. These video reference signals can therefore be used to synchronize the external components of a video subsystem (for example the ICs of a PC add-in card).

In addition to the timing references, valid video samples are marked with the 'video active' qualifier (VACT). In order to reduce the signal number of the video interface, several 8-bit modes have been implemented, where the reference signals are multiplexed into the data stream (see section 2.6.1.).

**2.8.1. HREF**

Fig. 2-26 illustrates the timing of the HREF signal relative to the analog input. The inactive period of HREF has a fixed length of 64 periods of the 13.5 MHz output clock rate. The total period of the HREF signal is expressed as  $\Phi_{nominal}$  and depends on the video line standard.



**Fig. 2-26:** HREF relative to input video

**2.8.2. VREF**

Figs. 2-27 and 2-28 illustrate the timing of the VREF signal relative to field boundaries of the two TV standards. The start of the VREF pulse is fixed, while the length is programmable in the range between 2 and 9 video lines via FP-RAM 0x153 [vlen].

**2.8.3. Odd/Even Information (FIELD)**

Information on whether the current field is odd or even is supplied through the relationship between the edge (either leading or trailing) of VREF and level of HREF. This relationship is fixed and shown in Figs. 2-27 and 2-28. The same information can be supplied to the FIELD pin, which can be enabled/disabled as output in FP-RAM 0x153 [enfieldq]. FP-RAM 0x153 [oepol] programs the polarity of this signal.

During normal operation the FIELD flag is filtered since most applications need interlaced signals. After filtering, the field type is synchronized to the input signal only if the last 8 fields have been alternating; otherwise, it always toggles. This filtering can be disabled with FP-RAM 0x140 [disoef]. In this case, the field information follows the odd/even property of the input video signal.

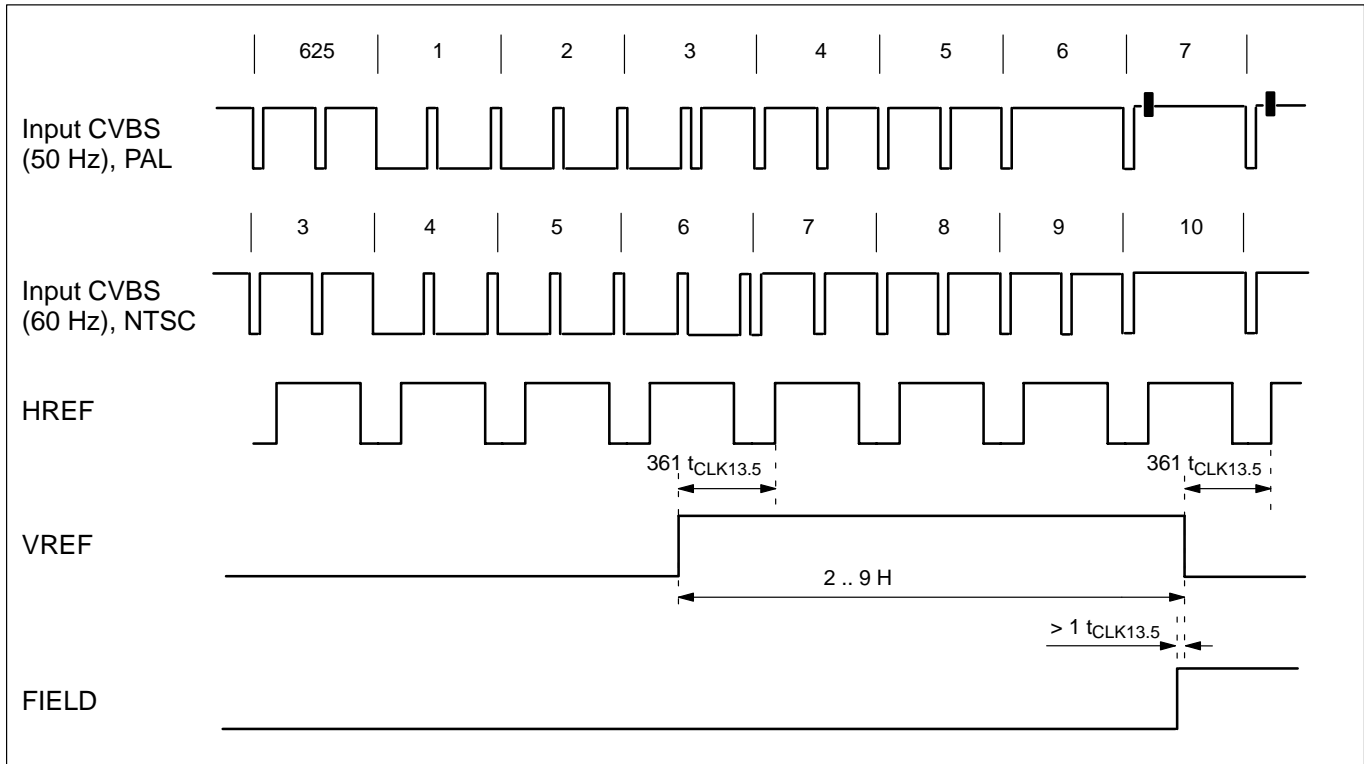


Fig. 2-27: VREF timing for ODD fields

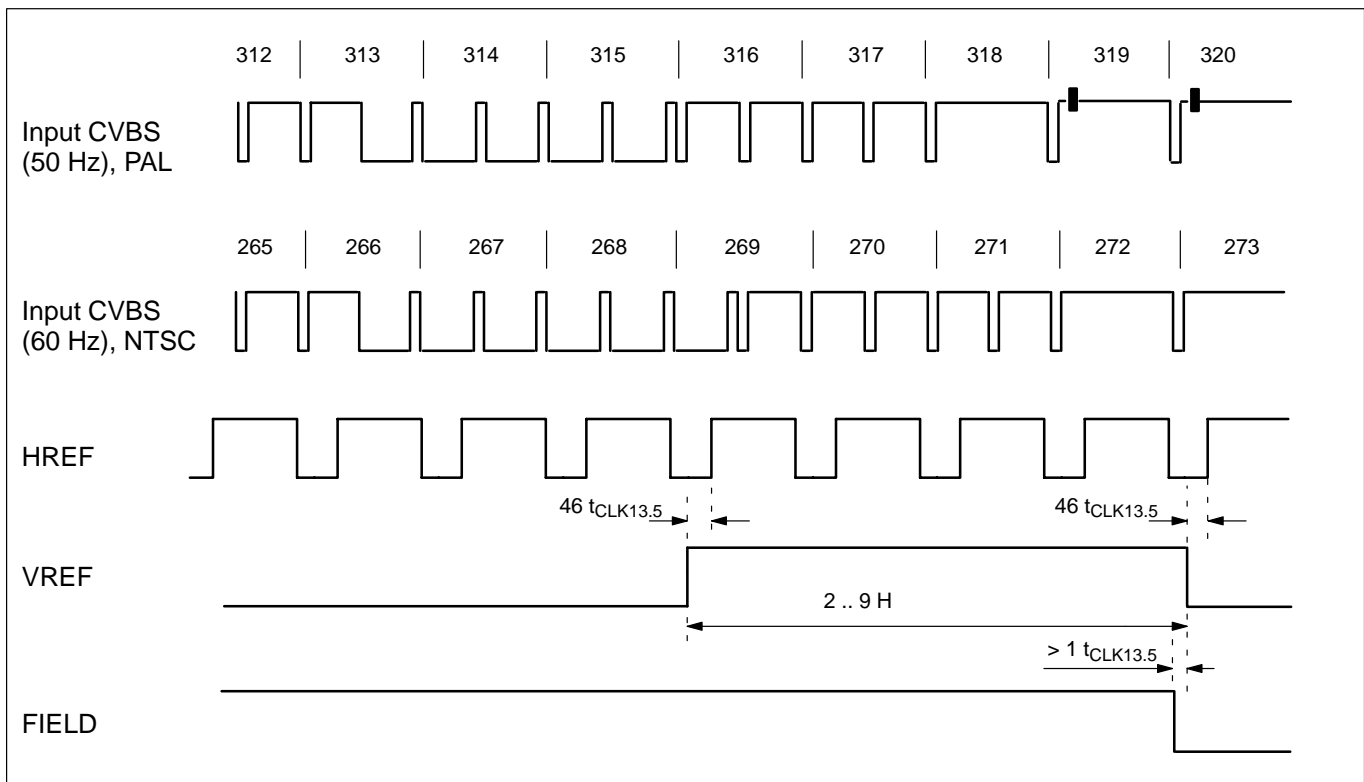


Fig. 2-28: VREF timing for EVEN fields



**2.8.4. VACT**

The ‘video active’ signal is a qualifier for valid video samples. Since scaled video data is stored internally, there are no invalid pixel within the VACT interval. VACT has a defined position relative to HREF depending on the window settings (see section 2.10.). The maximal window length depends on the minimal line length of the input signal. It is recommended to choose window sizes of less than 800 pixels. Sizes up to 864 are possible, but for non-standard input lines, VACT is forced inactive 4 PIXCLK cycles before the next trailing edge of HREF.

During the VBI-window, VACT can be enabled or suppressed with FP-RAM 0x138. Within this window, the VPX can deliver either sliced text data with a constant length of 64 samples or 1140 raw input samples. For applications that request a uniform window size over the whole field, a mode with a free programmable VACT is

supported [FP-RAM 0x140, vactmode]. The start and end position for the VACT signal relative to the trailing edge of HREF can be programmed within a range of 0 to 864 [FP-RAM 0x151, 0x152]. In this case, VACT no longer marks valid samples only.

The position of the valid data depends on the window definitions. It is calculated from the internal processor. The calculated delay of VACT relative to the trailing edge of HREF can be read via FP-RAM 0x10f (window 1) or 0x11f (window 2). Tables 2–8 and 2–9 show the formulas for the position of valid data samples relative to the trailing edge of HREF.

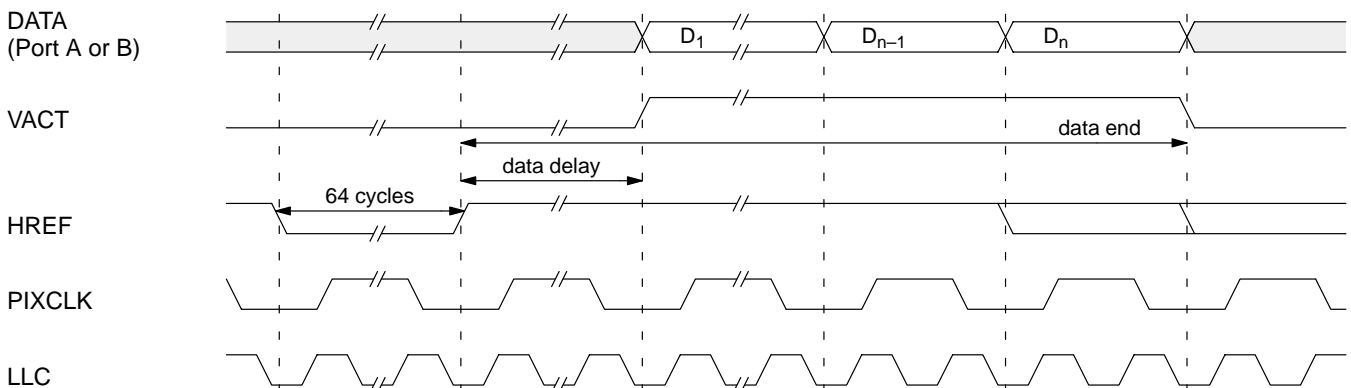
Fig. 2–29 illustrates the temporal relationship between the VACT and the HREF signals as a function of the number of pixels per output line and the horizontal dimensions of the window. The duration of the inactive period of the HREF is fixed to 64 clock cycles.

**Table 2–8:** Delay of valid output data relative to the trailing edge of HREF (single clock mode)

Mode	Data Delay	Data End
Video data	$(HBeg+HLen)*(720/NPix)-HLen$ for $NPix < 720$ $HBeg*(720/NPix)$ for $NPix \geq 720$	DataDelay + HLen
Raw VBI data	150	720
Sliced VBI data	726	790

**Table 2–9:** Delay of valid output data relative to the trailing edge of HREF (half clock mode)

Mode	Data Delay	Data End
Video data	$(HBeg+HLen)*(720/NPix)-2*HLen$ for $NPix < 360$ $HBeg*(720/NPix)$ for $NPix \geq 360$	DataDelay + 2*HLen
Raw VBI data	not possible!	not possible!
Sliced VBI data	662	790



**Fig. 2–29:** Relationship between HREF and VACT signals (single clock mode)

2.9. Operational Modes

The relationship between the video timing signals (HREF and VREF) and the analog input video is determined by the selected operational mode. Three such modes are available: the **Open Mode**, the **Forced Mode**, and the **Scan Mode**. These modes are selected via I<sup>2</sup>C commands [FP-RAM 0x140, settm, lattm].

2.9.1. Open Mode

In the Open Mode, both the HREF and the VREF signal track the analog video input. In the case of a change in the line standard (i.e. switching between the video input ports), HREF and VREF automatically synchronize to the new input. When no video is present, both HREF and VREF float to the idling frequency of their respective PLLs. During changes in the video input (drop-out, switching between inputs), the performance of the HREF and VREF signals is not guaranteed.

2.9.2. Scan Mode

In the Scan Mode, the HREF and VREF signals are always generated by free running hardware. They are therefore completely decoupled from the analog input. The output video data is always suppressed.

The purpose of the Scan Mode is to allow the external controller to freely switch between the analog inputs while searching for the presence of a video signal. Information regarding the video (standard, source, etc...) can be queried via I<sup>2</sup>C read.

In the Scan Mode, the video line standard of the VREF and HREF signals can be changed via I<sup>2</sup>C command. The transition always occurs at the first frame boundary after the I<sup>2</sup>C command is received. Fig. 2–30, below, demonstrates the behavior of the VREF signal during the transition from the 525/60 system to the 625/50 system (the width of the vertical reference pulse is exaggerated for illustration).

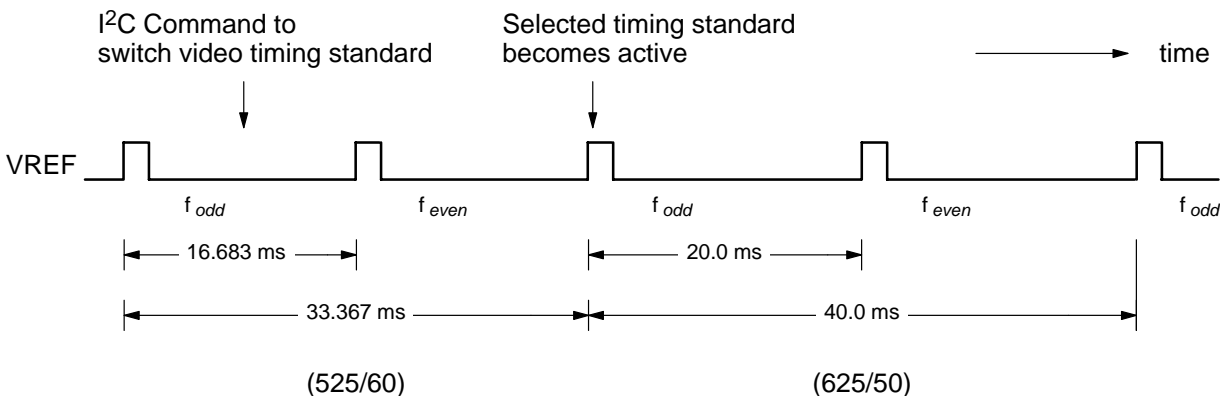


Fig. 2–30: Transition between timing standards

**Table 2–10:** Transition behavior as a function of operating mode

<b>Transition Behavior as a Function of Operating Mode</b>		
<b>Transition</b>	<b>Mode</b>	<b>Behavior</b>
Power up/Reset (no video)	Open	VREF, HREF: floats to steady state frequency of internal PLL
no video → video	Open	VREF, HREF: track the input signal
	Scan	no visible effect on any data or control signals – timing signals continue unchanged in free running mode – VACT signal is suppressed
video → no video	Open	VREF, HREF: floats to steady state frequency of internal PLL
	Scan	no visible effect on any data or control signals – timing signals continue unchanged in free running mode – VACT signal is suppressed
video → video	Open	VREF, HREF: track the input video immediately Data: available immediately after color decoder locks to input.
	Scan	no outwardly visible effect on any data or control signals. – timing signals continue unchanged in free running mode – VACT signal is suppressed

**2.10. Windowing the Video Field**

For each input video field, two non-overlapping video windows can be defined. The dimensions of these windows are supplied via I<sup>2</sup>C commands. The presence of two windows allows separate processing parameters such as filter responses and the number of pixels per line to be selected.

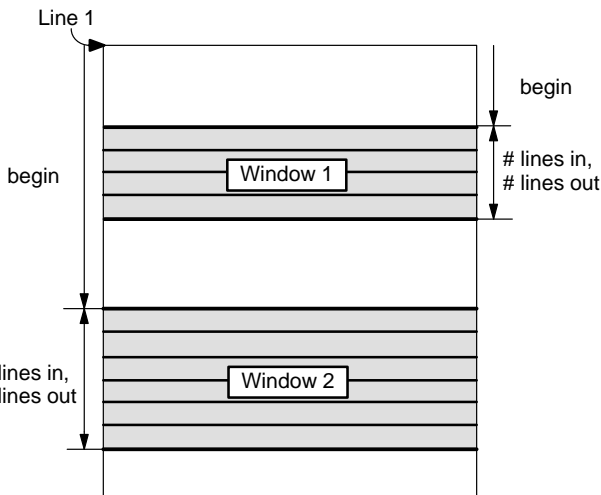
External control over the dimensions of the windows is performed by I<sup>2</sup>C writes to a window-load-table (WinLoadTab). For each window, a corresponding WinLoadTab is defined in a table of registers in the FP-RAM [window1: 0x120–128; window2: 0x12a–132]. **Data written to these tables does not become active until the corresponding latch bit is set** in the control register FP-RAM 0x140. A 2-bit flag specifies the field polarity over which the window is active [vlinei1,2].

Vertically, as can be seen in Fig. 2–31, each window is defined by a beginning line given in FP-RAM 0x120/12A, a number of lines to be read-in (FP-RAM 0x121/12B), and a number of lines to be output (FP-RAM 0x122/12C). Each of these values is specified in units of video lines.

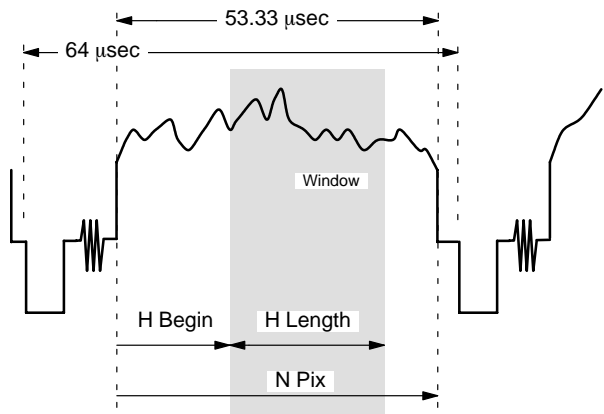
The option, to separately specify the number of input lines and the number of output lines, enables vertical compression. In the VPX, vertical compression is performed via simple line dropping. A nearest neighbor algorithm selects the subset of the lines for output. The presence of a valid line is signalled by the ‘video active’ qualifier (or the corresponding SAV/EAV code in embedded sync modes).

The numbering of the lines in a field of interlace video is dependent on the line standard. Figs. 2–33 and 2–34 illustrate the mapping of the window dimensions to the actual video lines. The indices on the left are the line numbers relative to the beginning of the frame. The indices on the right show the numbering used by the VPX. As seen here, the vertical boundaries of windows are defined relative to the field boundary. Spatially, the lines from field #1 are displayed above identically numbered from field #2. For example: On an interlace monitor, line #23 from field #1 is displayed directly above line #23 from field #2. There are a few restrictions to the vertical definition of the windows. Windows must not overlap vertically but can be adjacent. The first allowed line within a field is line #10 for 525/60 standards and line #7 for 625/50 standards. The number of output lines cannot be greater than the number of input lines (no vertical zooming). The combined height of the two windows cannot exceed the number of lines in the input field.

Horizontally, the windows are defined by a starting point defined in FP-RAM 0x123/12D and the length in FP-RAM 0x124/12E. They are both given relative to the number of pixels (NPix) in the active portion of the line (Fig. 2–32) selected in FP-RAM 0x125/12F. The scaling factor is calculated internally from NPix.



**Fig. 2–31:** Vertical dimensions of windows



**Fig. 2–32:** Horizontal dimensions of sampling window

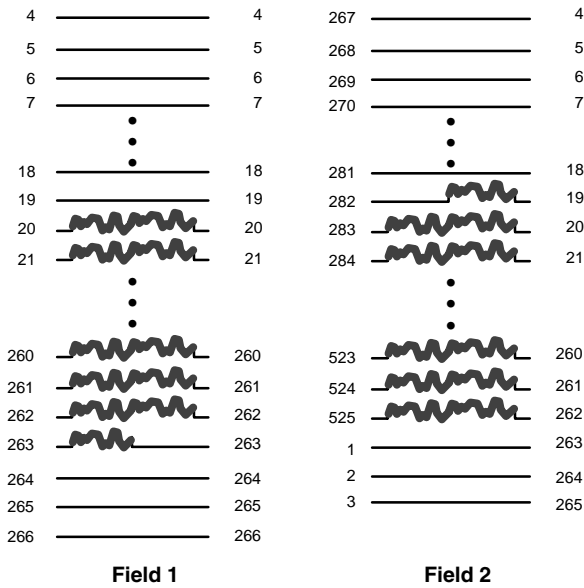


Fig. 2–33: Mapping for 525/60 line systems

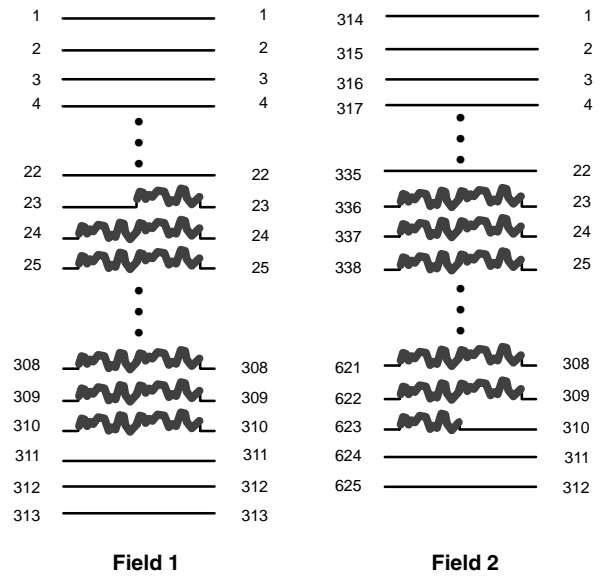


Fig. 2–34: Mapping for 625/50 line systems

There are some restrictions in the horizontal window definition. The total number of active pixels (N Pix) must be an even number. The maximum value for N Pix should be 800. Values up to 864 are possible, but for short input lines, video data is not guaranteed at the end of the line since VACT will be interrupted at the beginning of the next line. HLength should also be an even number. Obviously, the sum of HBegin and HLength may not be greater than N Pix.

Window boundaries are defined by writing the dimensions into the associated WinLoadTab and then setting the corresponding latch bit in the control word FP-RAM 0x140 [latwin]. Window definition data is latched at the beginning of the next video frame. Once the WinLoadTab data has been latched, the latch bit in the Control word is reset. By polling the Infoword (FP-RAM 0x141), the external controller can know when the window boundary data has been read. Window definition data can be changed only once per frame. Multiple window definitions within a single frame time are ignored and can lead to error.

2.11. Temporal Decimation

To cope with bandwidth restrictions in a system, the VPX supports temporal dropping of video frames via suppression of the VACT signal. Dropping will be applied for video windows only. There is no influence on the state of the VBI-window. This mode can be activated for each video window by setting the enable flag in the corresponding WinLoadTab (FP-RAM 0x121/12B). The selection in FP-RAM 0x157 determines how many frames will be output within an interval of 3000 frames. Note that this selection is applied for both video windows, but decimation can be enabled for each window separately. The number of valid frames is updated only if the corresponding latch flag in FP-RAM 0x140 [lattdec] is set. Frame dropping with temporal decimation can be combined with the field disable flags (FP-RAM 0x121/12B). Within valid video frames, each field type can be disabled separately.

## 2.12. Data Slicer

The data slicer is only available on VPX 3225D. Software drivers accessing the slicer I<sup>2</sup>C registers should therefore check the VPX part number.

### 2.12.1. Slicer Features

- 8-bit digital FBAS input
- 8-bit unbuffered ascii data output
- internal sync separation
- PAL and NTSC operation
- VBI and full-field mode
- automatic slicer adaptation
- text reception down to 30% eyeheight
- soft error correction
- simultaneous decoding of 4 different text services
  - main service: programmable
  - side service: VPS in line 16
  - side service: CAPTION in line 21
  - side service: WSS in line 23
- programmable text parameters for main service
  - bit rate
  - clock run-in
  - framing code
  - error tolerance
  - number of data bytes
- operation controlled by I<sup>2</sup>C registers

### 2.12.2. Data Broadcast Systems

Table 2–11 gives an overview of the most popular data broadcast systems throughout the world. The data slicer of the VPX 3225D can be programmed to acquire the different data systems via a set of I<sup>2</sup>C registers.

The various data broadcast systems are specified by a limited set of parameters:

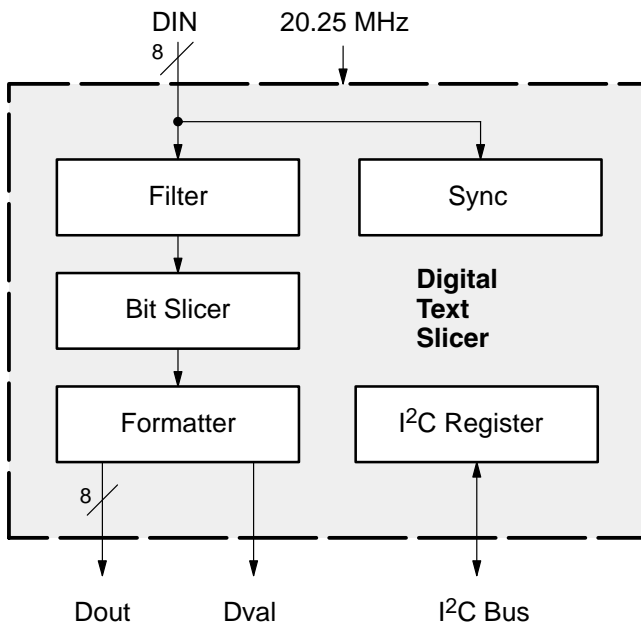
- line multiplex (VBI)
- bit rate
- modulation
- start timing
- clock run-in (CRI)
- framing code (FRC)
- number of data bytes

**Table 2–11:** Data Broadcast Systems

Text System	TV Standard	TV Lines	Bitrate	Modulation	Timing	CRI	FRC	No. Bytes
WST	PAL	6–22	6.937500Mbit/s	NRZ	10.3 μs	'5555'x	'27'x	42
VPS	PAL	16	2.500000Mbit/s	Bi-Phase	12.5 μs	'5555'x	'51'x	13
WSS	PAL	23	0.833333Mbit/s	Bi-Phase	11.0 μs	'3c78'x	'f8'x	11
Caption	PAL	21	1.006993Mbit/s	NRZ	10.5 μs	'aaa0'x	'c2'x	4
VITC	PAL	6–22	1.812500Mbit/s	NRZ	11.2 μs	?	?	9
Antiope	SECAM	6–22	6.203125Mbit/s	NRZ	10.5 μs	'5555'x	'e7'x	37
WST	NTSC	10–21	5.727272Mbit/s	NRZ	9.6 μs	'5555'x	'27'x	34
NABTS	NTSC	10–21	5.727272Mbit/s	NRZ	10.5 μs	'5555'x	'e7'x	33
Caption	NTSC	21	1.006993Mbit/s	NRZ	10.5 μs	'aaa0'x	'c2'x	4
2xCaption	NTSC	10–21	1.006993Mbit/s	NRZ	10.5 μs	'2aa0'x	'b7'x	4
VITC	NTSC	10–21	1.812500Mbit/s	NRZ	11.2 μs	?	?	9
CGMS	NTSC	20	0.450450Mbit/s	NRZ	11 μs	'10'b	–	3

**2.12.3. Slicer Functions**

The data slicer is inserted between the video ADC and the video output interface (see Fig. 1–1). It operates completely independent of the video front-end processing and has its own sync separator and a separate set of I<sup>2</sup>C registers. Figure 2–35 shows a more detailed block diagram of the digital data slicer.



**Fig. 2–35:** Slicer block diagram

**2.12.3.1. Input**

The slicer receives an 8-bit digitized FBAS signal which is clamped to the back porch level. The teletext signal amplitude can vary to a certain degree ( $\pm 3$  dB), as the slicer will adapt its internal slice level.

**2.12.3.2. Automatic Adaptation**

The slicer measures certain signal characteristics as DC offset, level, bandwidth, and phase error. A digital filter at the input stage is used to compensate bandwidth effects of the transmission channel. A DC shifter generates a DC free text signal even in case of co-channel interference. The internal slice level is adapted to the teletext signal level.

The adaption algorithm is designed for the signal characteristics of a WST or NABTS transmission. For text systems with significantly different signal characteristics (like CAPTION), the adaption should be disabled.

The teletext sampling rate is generated by a phase accumulator running at 20.25 MHz, which is synchronized

during framing code and clock run-in. The increment of the phase accumulator is programmable and can be used to set up any bit rate with the formula:

$$\text{increment} = 2048 * \text{bit rate} / 20.25 \text{ MHz}$$

**2.12.3.3. Standard Selection**

The main teletext service can be received in VBI lines only or in every line of each field (full-field mode). All parameters needed to identify a teletext service are programmable.

The slicer uses a reference of 24 bits to identify a teletext service. This reference is compared with the first received teletext bits which are often named clock run-in (CRI) and framing code (FRC). If there is a match, the slicer will start signal adaptation and write the following data to the output stage. The reference can be reduced in length by setting a mask for services which do not have a 16-bit clock run-in. Bit errors can be allowed by setting a tolerance level for every byte of the reference.

Additionally, the slicer can switch to other teletext services during dedicated lines of the VBI. These can be line 16 for VPS, line 21 for CAPTION, or line 23 for WSS. In this case, the parameters are hard wired. Table 2–13 shows with which I<sup>2</sup>C registers the text parameters are programmed and what the fixed settings for the side services are.

**2.12.3.4. Output**

The slicer delivers a synchronous burst of decoded teletext data bytes together with a data valid signal. This data stream is fed into the video FIFO of the VPX back-end. The data rate depends on the teletext bit rate (divided by 8), the length of the burst is programmable. The burst can optionally be extended to 64 bytes independently of the selected teletext service (fill64 mode). The dummy bytes needed to fill the burst to 64 bytes are delivered at a rate of 20.25 MHz. Normally, there is no output during lines without text transmission or unknown text signals. For some applications, it is necessary to have constant memory mapping. Therefore, the slicer can be forced to output 64 bytes per line even if no text is detected (dump mode).

The first 3 bytes of the data burst carry information to identify the received teletext service. The 2 byte line number contains a free running frame counter which can be used to identify data loss in the framebuffer of a capture application. The field bit can be used to identify field dependent services such as CAPTION. The 10-bit line number corresponds to the standard line counting scheme of a PAL composite video signal; in case of NTSC, the value “3” is subtracted.

The number of useful data bytes at the output is programmable and should be set accordingly to the selected teletext standard. To get “n” data bytes, the value “n+1” has to be programmed, because of the additional framing code byte.

In case of dump mode, byte numbers “1” and “2” are also valid for lines without detected text data. They are then followed by 62 dummy bytes.

**Table 2–12: Slicer Output Format**

Byte Number	Byte Format	Bit Format
1	line number high	b[7:3] frame counter b[2] odd field b[1:0] line number[9:8]
2	line number low	b[7:0] line number[7:0]
3	framing code	b[7:0] as transmitted
4	1st data byte	b[7:0] as transmitted
.	...	...
byte_cnt+2	last data byte	b[7:0] as transmitted
.	dummy byte	b[7:0] 00000000
.	...	...
64	dummy byte	b[7:0] 00000000

**Table 2–13: Slicer Programming (shaded values are hard wired)**

Programmable Parameter	I2C Register (hex)	Main Service	Side Services		
		e.g. WST	VPS	WSS	CAPTION
text reception	C9	on/off	on/off	on/off	on/off
TV standard	C9	pal/ntsc	pal	pal	ntsc
TV lines	C9	vbi/full field	16	23	21
bitrate	C1, C2	702	506	506	102
reference	BB, BC, BD	27 55 55	51 55 55	f8 3c 78	c2 aa a0
mask	B8, B9, BA	00 00 03	00 00 00	00 00 00	00 00 1f
tolerance	CE	01 01 01	01 01 01	01 01 01	01 01 01
byte_cnt	CF	43	28	14	5
64 byte mode	CF	on/off			
dump mode	CF	on/off			
adaption	C7	on/off	off		
soft error correction	C7	on/off	off		



**2.13. VBI Data Acquisition**

The VPX supports two different data acquisition modes for the vertical blanking interval: a bypass mode for raw data of the vertical blanking interval and a data slicer mode in which dedicated hardware provides constant packets of already decoded VBI-data. The data slicer mode is only available on VPX 3225D.

For both services, the start and end line of a vertical blanking interval (VBI) window can be defined for each field with FP-RAM 0x134–137. Teletext data can occur between lines 6 and 23 of each field. However, the VBI-window is freely programmable. It is possible to select the whole field (beginning with line #3). If video windows are enabled, the VBI-window should end two lines before the first valid line of the next video window. The VBI-window can be activated via bit[0] in FP-RAM 0x138.

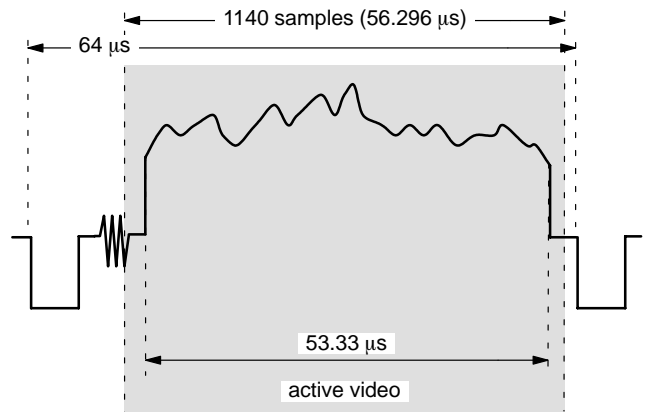
The identification of valid VBI-lines is possible with the VACT-signal (or the ‘active line’-flags in the modes with embedded syncs) or a special ‘data active’ signal on the TDO pin. Bit[10] of FP-RAM 0x154 selects between these two cases. In the default mode, VACT is used. The output of both signals can be suppressed optionally with bit[2] of FP-RAM 0x138. In this case, the graphic controller has to use only the HREF signal to mask the active video data.

In the ITU-R656 mode, VBI-data can be transmitted as vertical ancillary data (with 7 bit resolution + odd parity). The selections for the VBI-window will be updated by setting bit[11] in FP-RAM 0x138.

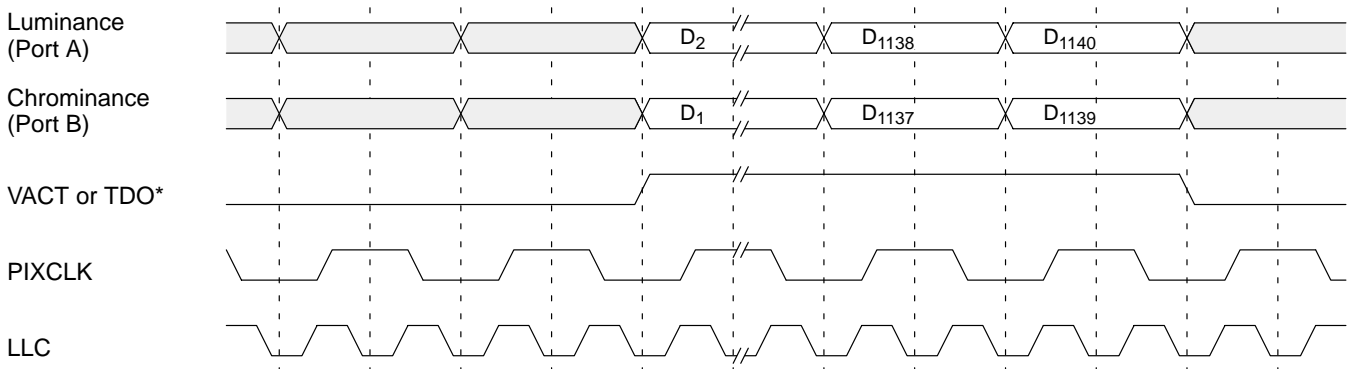
**2.13.1. Raw VBI Data**

The raw data mode is enabled with bit[1] of FP-RAM 0x138 (vbimode). This mode bypasses the luminance processing of the video front-end and delivers unmodified video samples from the ADC to the output ports.

During lines within the VBI-window, specified by the user settings in the corresponding Load-Table, the VPX internally acquires 1140 raw data bytes of the luminance input at a rate of 20.25 MHz corresponding to 56.296  $\mu$ s of the analog video (see Fig. 2–37). Chrominance data is not valid. The raw data samples are multiplexed internally to 570x16 bit on the luminance and chrominance port. The external timing corresponds to the video mode with 570 output samples for an uncropped window. Figure 2–36 shows the timing of both data ports and the necessary reference signals in this mode.



**Fig. 2–37:** Horizontal dimensions of the window for raw VBI-data



\* depending on bit[10] of FP-RAM 0x154

**Fig. 2–36:** Timing during lines with raw VBI-data (single clock mode)

**2.13.2. Sliced VBI Data**

The sliced data mode is enabled with bit[1] of the FP-RAM 0x138 (vbimode). This mode uses the integrated data slicer (available only on VPX 3225D) and delivers decoded data samples to the output ports.

The data slicer provides data packets of a constant size (filled with dummy bytes). The data packets have a default size of 64 bytes. To reduce the data rate for text systems with a smaller number of data bytes, the packet size can be reduced via FP-RAM 0x139.

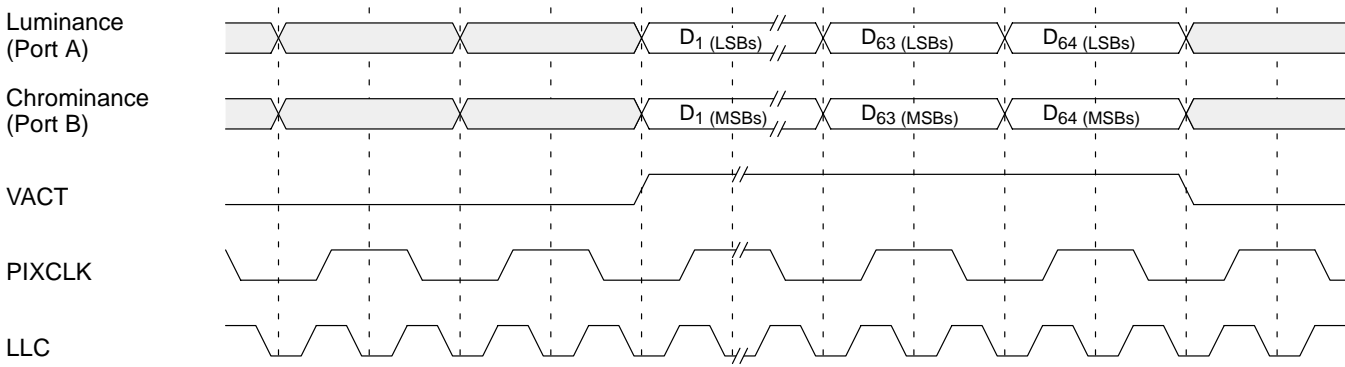
During lines within the VBI-window, specified by the user settings in the corresponding Load-Table, the VPX internally multiplexes the data slicer packets onto the luminance and chrominance outputs. Since the values 0, 254, and 255 are protected in the 8-bit output modes (ITU-R656, BStream), each slicer sample is separated into two nibbles for transmission. Table 2–14 shows the implemented data formats.

In each path, one nibble is transmitted twice. The LSB is inverted for odd parity. This assures that the values 0 and 255 will not occur (for the detection of embedded syncs). In the mode with embedded timing event codes, chrominance data will be limited additionally. No significant information will be lost since only Bit 0 and 1 will be modified. Figure 2–38 shows the timing of data and reference signals in this mode.

**Table 2–14:** Splitting of sliced data to luminance and chrominance output

Word	Bit No.							
	MSB				LSB			
	7	6	5	4	3	2	1	0
Slicer Data	S7	S6	S5	S4	S3	S2	S1	S0
Chroma Output	S7	S6	S5	S4	S7	S6	S5	S4
Luma Output	S3	S2	S1	S0	S3	S2	S1	S0

The splitting described above can be disabled by setting bit 6 in the ‘format\_select’ register. In this case, the sliced samples will be transmitted in the luminance path only. To avoid modification of valid data, the limitation of luminance data in the 8-bit output modes should be suppressed with bit 8 in the same register (note that luminance codes will not be protected).



**Fig. 2–38:** Timing during lines with sliced VBI-data (single clock mode)

**2.14. Control Interface**

**2.14.1. Overview**

Communication between the VPX and the external controller is performed serially via the I<sup>2</sup>C bus (pins SCL and SDA).

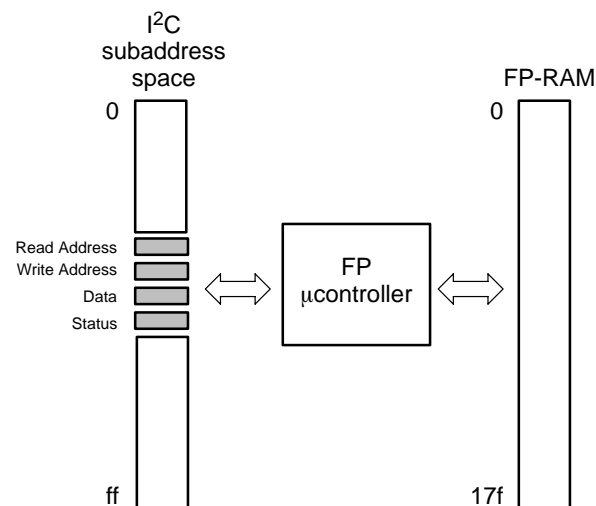
There are basically two classes of registers in the VPX. The first class of registers are the directly addressable I<sup>2</sup>C registers. These are registers embedded directly in the hardware. Data written to these registers is interpreted combinatorially directly by the hardware. These registers are all a maximum of 8-bits wide.

The second class of registers are the ‘FP-RAM registers’, the memory of the onboard microcontroller (Micronas Fast Processor). Data written into this class of registers is read and interpreted by the FP’s micro-code. Internally, these registers are 12 bits wide. Communications with these registers require I<sup>2</sup>C packets with 16-bit data payloads.

Communication with both classes of registers (I<sup>2</sup>C and FP-RAM) is performed via I<sup>2</sup>C. The format of the I<sup>2</sup>C telegram depends on which type of register is being addressed.

**2.14.2. I<sup>2</sup>C Bus Interface**

The VPX has an I<sup>2</sup>C bus slave interface and uses I<sup>2</sup>C clock synchronization to slow down the interface if required. The I<sup>2</sup>C bus interface uses one level of subaddressing. First, the bus address selects the IC, then a subaddress selects one of the internal registers.



**Fig. 2–39:** FP register addressing

The I<sup>2</sup>C interface of the VPX conforms to the I<sup>2</sup>C bus specification for the fast-mode. It incorporates slope control for the falling edges of the SDA and SCL signals. If the power supply of the VPX is switched off, both pins SCL and SDA float. External pull-up devices must be adapted to fulfill the required rise time for the fast-mode. For bus loads up to 200 pF, the pull-up device could be a resistor; for bus loads between 200 pF and 400 pF, the pull-up device can be a current source (3 mA max.) or a switched resistor circuit.

**2.14.3. Reset and I<sup>2</sup>C Device Address Selection**

The VPX can respond to one of two possible chip addresses. The address selection is made at reset by an externally supplied level on the OE pin. This level is latched on the inactive going edge of RES.

**Table 2–15:** I<sup>2</sup>C bus device addresses

OE	A6	A5	A4	A3	A2	A1	A0	R/W	hex
0	1	0	0	0	0	1	1	1/0	86/87
1	1	0	0	0	1	1	1	1/0	8e/8f

**2.14.4. Protocol Description**

Once the reset is complete, the IC is selected by asserting the device address in the address part of a I<sup>2</sup>C transmission. A device address pair is defined as a write address (86 hex or 8e hex) and a read address (87 hex or 8f hex). Writing is done by sending the device write address first, followed by the subaddress byte and one or two data bytes. For reading, the read subaddress has to be transmitted, first, by sending the device write address (86 hex or 8e hex) followed by the subaddress, a second start condition with the device read address (87 hex or 8f hex), and reading one or two bytes of data. It is not allowed to send a stop condition in between. This will result in reading erratic data.

The registers of the VPX have 8 or 16 bit data size; 16-bit registers are accessed by reading/writing two 8-bit data bytes with the high byte first. The order of the bits in a data/address/subaddress byte is always MSB first.

Figure 2–40 shows I<sup>2</sup>C bus protocols for read and write operations of the interface; the read operation requires an extra start condition after the subaddress and repetition of the read chip address, followed by the read data bytes. The following protocol examples use device address hex 86/87.

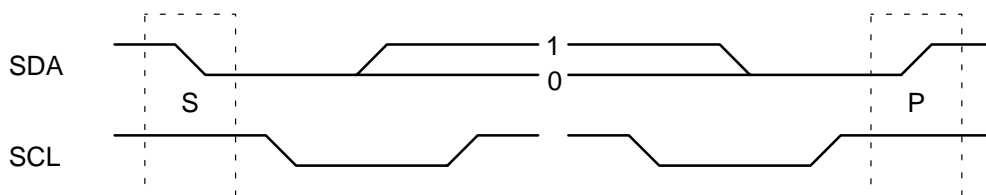
**Write to Hardware Control Registers**

S	10000110	ACK	sub-addr	ACK	send data-byte	ACK	P
---	----------	-----	----------	-----	----------------	-----	---

**Read from Hardware Control Registers**

S	10000110	ACK	sub-addr	ACK	S	10000111	ACK	receive data-byte	NAK	P
---	----------	-----	----------	-----	---	----------	-----	-------------------	-----	---

**Note:** S = I<sup>2</sup>C-Bus Start Condition  
 P = I<sup>2</sup>C-Bus Stop Condition  
 ACK = Acknowledge-Bit (active low on SDA from receiving device)  
 NAK = No Acknowledge-Bit (inactive high on SDA from receiving device)



**Fig. 2–40:** I<sup>2</sup>C bus protocol (MSB first)

**2.14.5. FP Control and Status Registers**

Due to the internal architecture of the VPX, the IC cannot react immediately to all I<sup>2</sup>C requests which interact with the embedded processor (FP). The maximum response timing is appr. 20 ms (one TV field) for the FP processor if TV standard switching is active. If the addressed processor is not ready for further transmissions on the I<sup>2</sup>C bus, the clock line SCL is pulled low. This puts the cur-

rent transmission into a wait state called clock synchronization. After a certain period of time, the VPX releases the clock and the interrupted transmission is carried on.

Before accessing the address or data registers for the FP interface (FPRD, FPWR, FPDAT), make sure that the busy bit of FP is cleared (FPSTA).

**Write to FP**

S	10000110	ACK	FPWR	ACK	send FP-address-byte high	ACK	send FP-address-byte low	ACK	P
S	10000110	ACK	FPDAT	ACK	send data-byte high	ACK	send data-byte low	ACK	P

**Read from FP**

S	10000110	ACK	FPRD	ACK	send FP-address-byte high	ACK	send FP-address-byte low	ACK	P			
S	10000110	ACK	FPDAT	ACK	S	10000111	ACK	receive data-byte high	ACK	receive data-byte low	NAK	P

## 2.15. Initialization of the VPX

### 2.15.1. Power-on-Reset

In order to completely specify the operational mode of the VPX, appropriate values must be loaded into the I<sup>2</sup>C and FP registers. After powering the VPX, an internal power-on-reset clears all the FP/I<sup>2</sup>C-Registers. An initialization routine loads the default values for both the I<sup>2</sup>C and FP registers from internal program ROM. The external  $\overline{\text{RES}}$  pin forces all outputs to be tri-stated. At the inactive going edge of the  $\overline{\text{RES}}$  pin,  $\overline{\text{OE}}$  and FIELD are read in for configuration. The FIELD pin is internally pulled down, an external pull-up resistor could be used to define a different power-on configuration. The power-on configuration is read on every rising edge of the external  $\overline{\text{RES}}$  pin.

Either inactive (tri-state) or active output pins could be chosen with the FIELD pin at the inactive going edge of  $\overline{\text{RES}}$ . In the inactive state, all relevant output pins are tri-stated, this includes Port A, Port B, HREF, VREF, FIELD, VACT, PIXCLK, LLC, and LLC2. In the active setup, all of these pins are driven. Table 2–16 gives an overview of the different setups. Additionally, the data ports A and B can be tri-stated with an external pullup resistor at the output enable pin  $\overline{\text{OE}}$ . The ports can be reactivated either by the  $\overline{\text{OE}}$  pin or via setting bit 7 in I<sup>2</sup>C register 0xF2 ("oeq\_dis").

The VPX always comes up in NTSC square pixel mode (640x240, both fields). In the case of inactive low power mode, the internal H-Sync scheduler is switched off, as in normal low power mode. After enabling the chip via I<sup>2</sup>C Interface, the H-Sync scheduler is enabled and the chips goes into a normal active NTSC operation condition.

### 2.15.2. Software Reset

The VPX provides the possibility of a software reset generated via I<sup>2</sup>C command (I<sup>2</sup>C register 0xAA, bit 2). Be aware that this software reset does not activate the configuration read-in during power-on reset.

### 2.15.3. Low Power Mode

The VPX goes into low power mode, if the inactive mode has been chosen. This is equal to the manual chosen low-power mode. Note, that every manual selection of the power mode (full or low-power) overwrites (resets!) the power-up configuration. However, the current configuration cannot be read via the corresponding I<sup>2</sup>C register. Other restrictions are that the selection of the low-power mode limits the rate of the I<sup>2</sup>C-interface to 100 kHz, and that the IC comes up with full power consumption until the low-power circuit becomes active.

**Table 2–16:** State of the pins during and after reset

Pins	Reset Active	Inactive Setup (FIELD=0)	Active Setup (FIELD=1)
Port A	Tri-State	Tri-State	active ( $\overline{\text{OE}}=0$ )
Port B	Tri-State	Tri-State	active ( $\overline{\text{OE}}=0$ )
HREF	Tri-State	Tri-State	active
VREF	Tri-State	Tri-State	active
FIELD	pull down	Tri-State	active
VACT	Tri-State	Tri-State	active
PIXCLK	Tri-State	Tri-State	active 13.5 MHz
LLC	Tri-State	Tri-State	active 27 MHz
TDO/ LLC2	Tri-State	Tri-State	active program- mable output

With the FIELD pin pulled down at the inactive going edge of  $\overline{\text{RES}}$ , the VPX comes up in the low power mode. This mode is introduced for power consumption critical applications. It can be turned on and off with bit[1:0] in the I<sup>2</sup>C register 0xAA ("lowpow"). There are three levels of low power mode. When any of them is turned on, the VPX waits for at least one complete video scan line in order to complete all internal tasks and then goes into tri-state mode. The exact moment is not precisely defined, so care should be taken to deactivate the system using VPX data before the end of the video scan line in which the VPX is switched into low power mode. During the low power mode, all the I<sup>2</sup>C and FP registers are preserved, so that the VPX restores its normal operation as soon as low power mode is turned off, without need for any re-initialization. On the other hand, all the I<sup>2</sup>C and FP registers can be read/written as usual. The only exception is the third level (value of 3 in I<sup>2</sup>C register 0xAA) of low power. In that mode, I<sup>2</sup>C speeds above 100 kbit/sec are not allowed. In modes 1 and 2, I<sup>2</sup>C can be used up to the full speed of 400 kbit/s.

## 2.16. JTAG Boundary-Scan, Test Access Port (TAP)

The design of the Test Access Port, which is used for Boundary-Scan Test, conforms to standard IEEE 1149.1-1990, with one exception. Also included is a list of the mandatory instructions supported, as well as the optional instructions. The following comprises a brief overview of some of the basics, as well as any optional features which are incorporated. The IEEE 1149.1 document may be necessary for a more concise description. Finally, an adherence section goes through a checklist of topics and describes how the design conforms to the standard.

The implementation of the instructions HIGHZ and CLAMP conforms to the supplement P1149.1/D11 (October 1992) to the standard 1149.1-1990.

### 2.16.1. General Description

The TAP in the VPX is incorporated using the four signal interface. The interface includes TCK, TMS, TDI, and TDO. The optional TRESET signal is not used. This is not needed because the chip has an internal power-on-reset which will automatically steer the chip into the TEST-LOGIC-RESET state. The goal of the interface is to provide a means to test the boundary of the chip. There is no support for internal or BIST (built-in self test). The one exception to IEEE 1149.1 is that the TDO output is shared with the LLC2 signal. This was necessitated due to I/O restrictions on the chip (see section 2.16.3. "Exceptions to IEEE 1149.1" for more information).

### 2.16.2. TAP Architecture

The TAP function consists of the following blocks: TAP-controller, instruction register, boundary-scan register, bypass register, optional device identification register, and master mode register.

#### 2.16.2.1. TAP Controller

The TAP controller is responsible for responding to the TCK and TMS signals. It controls the transition between states of this device. These states control selection of the data or instruction registers, and the actions which occur in these registers. These include capture, shifting, and update. See Fig. 5–1 of IEEE 1149.1 for TAP state diagram.

#### 2.16.2.2. Instruction Register

The instruction register chooses which one of the data registers is placed between the TDI and TDO pins when the select data register state is entered in the TAP controller. When the select instruction register state is active, the instruction register is placed between the TDI and TDO.

##### Instructions

The following instructions are incorporated:

- bypass
- sample/preload
- extest
- master mode
- ID code
- HIGHZ
- CLAMP

#### 2.16.2.3. Boundary Scan Register

The boundary scan register (BSR) consists of boundary scan cells (BSCs) which are distributed throughout the chip. These cells are located at or near the I/O pad. It allows sampling of inputs, controlling of outputs, and shifting between each cell in a serial fashion to form the BSR. This register is used to verify board interconnect.

##### Input Cell

The input cell is constructed to achieve capture only. This is the minimal cell necessary since Internal Test (INTEST) is not supported. The cell captures either the system input in the CAPTURE-DR state or the previous cells output in the SHIFT-DR state. The captured data is then available to the next cell. No action is taken in the UPDATE-DR state. See Figure 10–11 of IEEE 1149.1 for reference.

##### Output Cell

The output cell will allow both capture and update. The capture flop will obtain system information in the CAPTURE-DR state or previous cells information in the SHIFT-DR state. The captured data is available to the next cell. The captured or shifted data is downloaded to the update flop during the UPDATE-DR state. The data from the update flop is then multiplexed to the system output pin when the EXTEST instruction is active. Otherwise, the normal system path exists where the signal from the system logic flows to the system output pin. See Fig. 10–12 of IEEE 1149.1 for reference.

### Tristate Cell

Each group of output signals, which are tristatable, is controlled by a boundary scan cell (output cell type). This allows either the normal system signal or the scanned signal to control the tristate control. In the VPX, there are four such tristate control cells which control groups of output signals (see section “Output Driver Tristate Control” for further information).

### Bidirect Cell

The bidirect cell is comprised of an input cell and a tristate cell as described in the IEEE standard. The signal PIXCLK is a bidirectional signal.

#### 2.16.2.4. Bypass Register

This register provides a minimal path between TDI and TDO. This is required for complicated boards where many chips may be connected in serial.

#### 2.16.2.5. Device Identification Register

This is an optional 32-bit register which contains the Micronas identification code (JEDEC controlled), part and revision number. This is useful in providing the tester with assurance that the correct part and revision are inserted into a PCB.

#### 2.16.2.6. Master Mode Data Register

This is an optional register used to control an 8-bit test register in the chip. This register supports shift and update. No capture is supported. This was done so the last word can be shifted out for verification.

### 2.16.3. Exception to IEEE 1149.1

There is one exception to IEEE 1149.1. The exception is to paragraphs 3.1.1.c., 3.5.1.b, and 5.2.1.d (TEST-LOGIC-RESET state). Because of pin limitations on the chip, a pin is shared for two functions. When the circuit is in the TEST-LOGIC-RESET state, the LLC2 signal is driven out the TDO/LLC2 pin. When the circuit leaves the TEST-LOGIC-RESET state, the TDO signal is driven on this line. As long as the circuit is not in the TEST-LOGIC-RESET state, all the rules for application of the TDO signal adhere to the IEEE1149.1 spec.

Since the VPX uses the JTAG function as a boundary-scan tool, the VPX does not sacrifice test of this pin since it is verified by exercising JTAG function. The designer of the PCB must make careful note of this fact, since he will not be able to scan into chips receiving the LLC2 signal via the VPX. The PCB designer may want to put this chip at the end of the chain or bring the VPX TDO out separately and not have it feed another chip in a chain.

### 2.16.4. IEEE 1149.1-1990 Spec Adherence

This section defines the details of the IEEE1149.1 design for the VPX. It describes the function as outlined by IEEE1149.1, section 12.3.1. The section of that document is referenced in the description of each function.

#### 2.16.4.1. Instruction Register

(Section 12.3.1.b.i of IEEE 1149.1-1990)

The instruction register is three bits long. No parity bit is included. The pattern loaded in the instruction register during CAPTURE-IR is binary “101” (MSB to LSB). The two LSBs are defined by the spec to be “01” (bit 1 and bit 0) while the MSB (bit 2) is set to “1”.

#### 2.16.4.2. Public Instructions

(Section 12.3.1.b.ii of IEEE 1149.1-1990)

A list of the public instructions is as follows:

Instruction	Code (MSB to LSB)
EXTEST	000
SAMPLE/PRELOAD	001
ID CODE	010
MASTER MODE	011
HIGHZ	100
CLAMP	110
BYPASS	100 – 111

The EXTEST and SAMPLE/PRELOAD instructions both apply the boundary scan chain to the serial path. The ID CODE instruction applies the ID register to the serial chain. The BYPASS, the HIGHZ, and the CLAMP instructions apply the bypass register to the serial chain.

The MASTER MODE instruction is a test data instruction for public use. It provides the ability to control an 8-bit test register in the chip.

**2.16.4.3. Self-Test Operation**

(Section 12.3.1.b.iii of IEEE 1149.1-1990).

There is no self-test operation included in the VPX design which is accessible via the TAP.

**2.16.4.4. Test Data Registers**

(Section 12.3.1.b.iv of IEEE 1149.1-1990).

The VPX includes the use of four test data registers. They are the required bypass and boundary scan registers, the optional ID code register, and the master mode register.

The bypass register is, as defined, a 1-bit register accessed by codes 100 through 111, inclusive. Since the design includes the ID code register, the bypass register is not placed in the serial path upon power-up or Test-Logic-Reset.

The master mode is an 8-bit test register which is used to force the VPX into special test modes. This is reset upon power-on-reset. This register supports shift and update only. It is not recommended to access this register. The loading of that register can drive the IC into an undefined state.

**2.16.4.5. Boundary Scan Register**

(Section 12.3.1.b.v of IEEE 1149.1-1990)

The boundary scan chain has a length of 38 shift registers. The scan chain order is specified in the section “Pin Connections”.

**2.16.4.6. Device Identification Register**

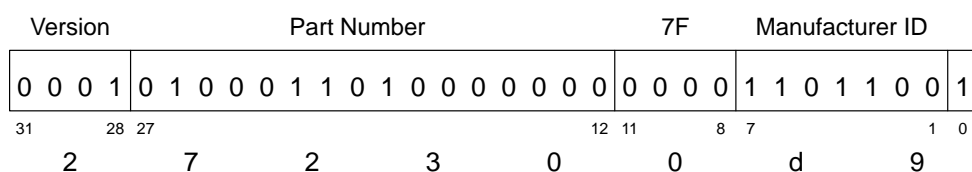
(Section 12.3.1.b.vi of IEEE 1149.1-1990)

The manufacturer’s identification code is “6C”<sub>(hex)</sub> for Micronas. The general implementation scheme uses only the 7 LSBs and excludes the MSB, which is the parity bit. The part number is “7230”<sub>(hex)</sub>. in case of VPX 3225D and “7231”<sub>(hex)</sub>. in case of VPX 3224D. The version code starts from “1”<sub>(hex)</sub> and changes with every revision. The version number relates to changes of the chip interface only.

**2.16.4.7. Performance**

(Section 12.3.1.b.vii of IEEE 1149.1-1990)

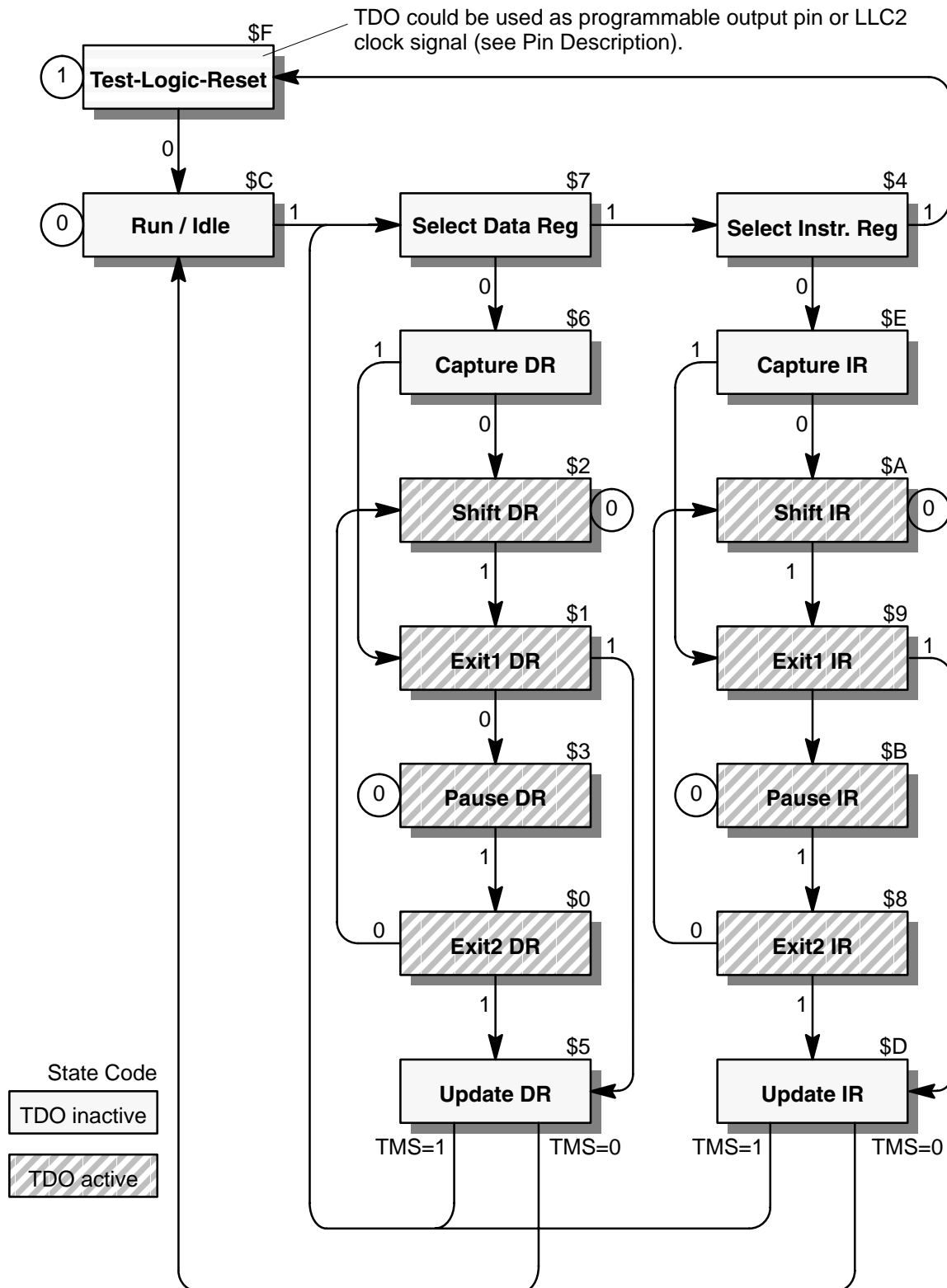
See section “Specification” for further information.



**Fig. 2–41:** Device identification register



**TAP State Transitions**



State transitions are dependent on the value of TMS, synchronized by TCK.

**Fig. 2-42:** TAP state transitions

\_\_\_\_\_

— This is the BSDL for the 44-Pin Version of the VPXD design.

\_\_\_\_\_

Library IEEE;  
Use work.STD\_1149\_1\_1990.ALL;

Entity VPXD\_44 is  
Generic (Physical\_Pin\_Map:string := "UNDEFINED");

```
Port(                                     —define ports
    TDI,TCK,TMS:                          in bit;
    TDO,HREF,VREF,FIELD:                  out bit;
    A:                                     out bit_vector(7 downto 0);
    PVDD,PVSS:                             linkage bit;
    PIXCLK:                                out bit;
    OEQ:                                    in bit;
    LLC, VACT:                              out bit;
    B:                                     out bit_vector(7 downto 0);
    SDA,SCL:                               inout bit;
    VSS,XTAL2,XTAL1,VDD:                  linkage bit;
    RESQ:                                   in bit;
    AVDD,AVSS,VRT,ISGND:                  linkage bit;
    CIN,VIN1,VIN2,VIN3:                  in bit
);
```

Attribute Pin\_Map of VPXD\_44 : Entity is Physical\_Pin\_Map;

```
constant Package_44 : Pin_Map_String :=    —map pins to signals
    "TDI      : 1 " &
    "TCK      : 2 " &
    "TDO      : 3 " &
    "HREF     : 4 " &
    "VREF     : 5 " &
    "FIELD    : 6 " &
    "A        : (7,8,9,10,14,15,16,17)" &
    "PVDD     : 11 " &
    "PIXCLK   : 12 " &
    "PVSS     : 13 " &
    "OEQ      : 18 " &
    "LLC      : 19 " &
    "VACT     : 20 " &
    "B        : (21,22,23,24,25,26,27,28)," &
    "SDA      : 29 " &
    "SCL      : 30 " &
    "RESQ     : 31 " &
    "VSS      : 32 " &
    "VDD      : 33 " &
    "XTAL2    : 34 " &
    "XTAL1    : 35 " &
    "AVDD     : 36 " &
    "CIN      : 37 " &
    "AVSS     : 38 " &
    "VIN1     : 39 " &
    "VIN2     : 40 " &
    "VRT      : 41 " &
    "VIN3     : 42 " &
    "ISGND    : 43 " &
    "TMS      : 44 " ;
```

Attribute Tap\_Scan\_In of TDI : signal is true; —define JTAG Controls

Attribute Tap\_Scan\_Mode of TMS : signal is true;

Attribute Tap\_Scan\_Out of TDO : signal is true;

Attribute Tap\_Scan\_Clock of TCK : signal is (10.0e6,Both); —max frequency and levels TCK can be stopped at.

Attribute Instruction\_Length of VPXD\_44: entity is 3; —define instr. length

Attribute Instruction\_Opcode of VPXD\_44: entity is  
"EXTTEST" & —External Test

"SAMPLE	(001)," &	—Sample/Preload	
"IDCODE	(010)," &	—ID Code	
"MASTERMODE	(011)," &	—Master Mode (internal Test)	
"HIGHZ	(100)," &	— Highz	
"CLAMP"	(110)," &	— Clamp	
"BYPASS	(100,101,110,111);"	—Bypass	
Attribute Register_Access	of VPXD_44: entity is	—instr. vs register	
"BOUNDARY	(EXTEST,SAMPLE)," &	—control	
"BYPASS	(BYPASS, HIGHZ, CLAMP)," &		
"IDCODE[32]	(IDCODE)," &		
"MASTERMODE[8]	(MASTERMODE)";		
Attribute INSTRUCTION_Capture	of VPXD_44: entity is "101";	—captured instr.	
Attribute IDCODE_Register	of VPXD_44: entity is		
	"0001" &	—initial rev	
	"0100011010000000" &	—part numb. 7230	
	"0000" &	—7F Count	
	"1101100" &	—Micronas Code-Parity	
	"1";	—Mandatory LSB	
Attribute Boundary_Cells	of VPXD_44: entity is "BC_1,BC_4";	—BC_1 for output cell —BC_4 for input cell	
Attribute Boundary_Length	of VPXD_44: entity is 38;	—Boundary scan length	
Attribute Boundary_Register	of VPXD_44: entity is	—Boundary scan defin.	
— num cell port	function safe ccel disval rslt		
" 37 (BC_4, VIN3,	input, X	)" &	
" 36 (BC_4, VIN2,	input, X	)" &	
" 35 (BC_4, VIN1,	input, X	)" &	
" 34 (BC_4, CIN,	input, X	)" &	
" 33 (BC_1, *,	internal, X	)" &	—low power mode
" 32 (BC_4, RESQ,	input, X	)" &	
" 31 (BC_4, SCL,	input, X	)" &	
" 30 (BC_1, SCL,	output3, X,	30, 1, Z	)" & —open collector
" 29 (BC_4, SDA,	input, X	)" &	
" 28 (BC_1, SDA,	output3, X,	28, 1, Z	)" & —open collector
" 27 (BC_1, B(0),	output3, X,	19, 1, Z	)" &
" 26 (BC_1, B(1),	output3, X,	19, 1, Z	)" &
" 25 (BC_1, B(2),	output3, X,	19, 1, Z	)" &
" 24 (BC_1, B(3),	output3, X,	19, 1, Z	)" &
" 23 (BC_1, B(4),	output3, X,	19, 1, Z	)" &
" 22 (BC_1, B(5),	output3, X,	19, 1, Z	)" &
" 21 (BC_1, B(6),	output3, X,	19, 1, Z	)" &
" 20 (BC_1, B(7),	output3, X,	19, 1, Z	)" &
" 19 (BC_1, *,	control, X	)" &	—control
" 18 (BC_1, VACT,	output3, X,	16, 1, Z	)" &
" 17 (BC_1, LLC,	output3, X,	16, 1, Z	)" &
" 16 (BC_1, *,	control, X	)" &	—control
" 15 (BC_4, OEQ,	input, X	)" &	
" 14 (BC_1, A(0),	output3, X,	8, 1, Z	)" &
" 13 (BC_1, A(1),	output3, X,	8, 1, Z	)" &
" 12 (BC_1, A(2),	output3, X,	8, 1, Z	)" &
" 11 (BC_1, A(3),	output3, X,	8, 1, Z	)" &
" 10 (BC_1, *,	control, X	)" &	—control
" 9 (BC_1, PIXCLK,	output3, X,	10, 1, Z	)" &
" 8 (BC_1, *,	control, X	)" &	—control
" 7 (BC_1, A(4),	output3, X,	8, 1, Z	)" &
" 6 (BC_1, A(5),	output3, X,	8, 1, Z	)" &
" 5 (BC_1, A(6),	output3, X,	8, 1, Z	)" &
" 4 (BC_1, A(7),	output3, X,	8, 1, Z	)" &
" 3 (BC_1, *,	control, X,	, 1, Z	)" & —control
" 2 (BC_1, FIELD,	output3, X,	3, 1, Z	)" &
" 1 (BC_1, VREF,	output3, X,	16, 1, Z	)" &
" 0 (BC_1, HREF,	output3, X,	16, 1, Z	)";

End VPXD\_44;

## 2.17. Enable/Disable of Output Signals

In order to enable the output pins of the VPX to achieve the high impedance/tristate mode, various controls have been implemented. The following paragraphs give an overview of the different tristate modes of the output signals. It is valid for all output pins, except the XTAL2 (which is the oscillator output) and the VRT pin (which is an analog reference voltage).

### BS (Boundary Scan) Mode:

The tristate control by the test access port TAP for boundary scan has the highest priority. Even if the TAP-controller is in the EXTEST or CLAMP mode, the tristate behavior is only defined by the state of the different boundary scan registers for enable control. If the TAP controller is in HIGHZ mode, then all output pins are in tristate mode independently of the state of the different boundary scan registers for enable control.

### RESET State:

If the TAP-controller is not in the EXTEST mode, then the RESET-state defines the state of all digital outputs. The only exception is made for the data output of the boundary scan interface TDO. If the circuit is in reset condition ( $\overline{RES} = 0$ ), then all output interfaces are in tristate mode.

### I<sup>2</sup>C Control:

The tristate condition of groups of signals can also be controlled by setting the I<sup>2</sup>C-Register 0xF2. If the circuit is neither in EXTEST mode nor RESET state, then the I<sup>2</sup>C-Register 0xF2 defines whether the output is in tristate condition or not (see "I<sup>2</sup>C-Registers VPX Back-end").

### Output Enable Input $\overline{OE}$ :

The output enable signal  $\overline{OE}$  only effects the video output ports. If the previous three conditions do not cause the output drivers to go into high impedance mode, then the  $\overline{OE}$  signal defines the driving conditions of the video data ports.

The  $\overline{OE}$  pin function can be disabled via I<sup>2</sup>C register 0xF2 [oeq\_dis]. The  $\overline{OE}$  signal will either directly connect the output drivers or it will be latched internally with the LLC signal depending on I<sup>2</sup>C register 0xF2 [latoeq]. Additionally, a delay of 1 LLC clock cycle can be enabled with I<sup>2</sup>C register 0xF2 [oeqdel].

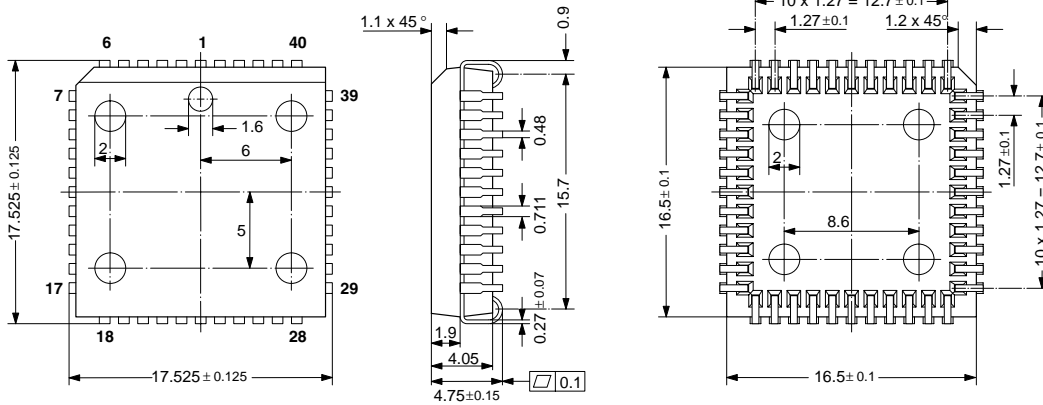
**Table 2–17:** Output driver configuration

EXTEST	RESET	I <sup>2</sup> C	OE#	Driver Stages
active	–	–	–	Output driver stages are defined by the state of the different boundary scan enable registers.
inactive	active	–	–	Output drivers are in high impedance mode.
inactive	inactive	= 0	–	Output drivers are in high impedance mode. PIXCLK is working.
inactive	inactive	= 1	= 0	Output drivers HREF, VREF, FIELD, VACT, LLC, are working. Outputs A[7:0] and B[7:0] are working
inactive	inactive	= 1	= 1	Output drivers HREF, VREF, FIELD, VACT, LLC, are working. Output drivers of A[7:0] and B[7:0] are in high impedance mode.

**Remark:** EXTEST mode is an instruction conforming to the standard for Boundary Scan Test IEEE 1149.1 – 1990

3. Specification

3.1. Outline Dimensions



SPGS7003-2/3E

**Fig. 3-1:**  
 44-Pin Plastic Leaded Chip Carrier Package  
**(PLCC44)**  
 Weight approximately 2.5 g  
 Dimensions in mm

3.2. Pin Connections and Short Descriptions

NC = not connected; leave vacant

X = obligatory

Pin No. PLCC44	Pin Name	Pin Type	Connection (if not used)	Short Description
1	TDI	IN	NC	Boundary-Scan-Test Data Input
2	TCK	IN	NC	Boundary-Scan-Test Clock Input
3	TDO LLC2 DACT	OUT	NC	Boundary-Scan-Test Data Output LLC / 2 = 13.5MHz Output Active VBI Data Qualifier Output
4	HREF	OUT	NC	Horizontal Reference Output
5	VREF	OUT	NC	Vertical Reference Output
6	FIELD	OUT	NC	Odd/Even Field Identifier Output
7	A7	OUT	NC	Port A – Video Data Output
8	A6	OUT	NC	Port A – Video Data Output
9	A5	OUT	NC	Port A – Video Data Output
10	A4	OUT	NC	Port A – Video Data Output
11	PVDD	SUPPLY	X	Supply Voltage Pad Circuits
12	PIXCLK	OUT	NC	Pixel Clock Output
13	PVSS	SUPPLY	X	Ground, Pad Circuits
14	A3	OUT	NC	Port A – Video Data Output

## Pin Connections and Short Descriptions, continued

Pin No. PLCC44	Pin Name	Type	Connection (if not used)	Short Description
15	A2	OUT	NC	Port A – Video Data Output
16	A1	OUT	NC	Port A – Video Data Output
17	A0	OUT	NC	Port A – Video Data Output
18	$\overline{OE}$	IN	VSS	Output Ports Enable Input
19	LLC	OUT	NC	PIXCLK * 2 = 27 MHz Output
20	VACT	OUT	NC	Active Video Qualifier Output
21	B7	OUT	NC	Port B – Video Data Output
22	B6	OUT	NC	Port B – Video Data Output
23	B5	OUT	NC	Port B – Video Data Output
24	B4	OUT	NC	Port B – Video Data Output
25	B3	OUT	NC	Port B – Video Data Output
26	B2	OUT	NC	Port B – Video Data Output
27	B1	OUT	NC	Port B – Video Data Output
28	B0	OUT	NC	Port B – Video Data Output
29	SDA	IN/OUT	NC	I <sup>2</sup> C Bus Data
30	SCL	IN/OUT	NC	I <sup>2</sup> C Bus Clock
31	$\overline{RES}$	IN	X	Reset Input
32	VSS	SUPPLY	X	Ground, Digital Circuitry
33	VDD	SUPPLY	X	Supply Voltage, Digital Circuitry
34	XTAL2	OSC OUT	X	Analog Crystal Output
35	XTAL1	OSC IN	X	Analog Crystal Input
36	AVDD	SUPPLY	X	Supply Voltage, Analog Circuitry
37	CIN	AIN	NC	Analog Chroma Input
38	AVSS	SUPPLY	X	Ground, Analog Circuitry
39	VIN1	AIN	NC	Analog Video 1 Input
40	VIN2	AIN	NC	Analog Video 2 Input
41	VRT	Reference	X	Reference Voltage Top, Video ADC
42	VIN3	AIN	NC	Analog Video 3 Input
43	ISGND	SUPPLY	X	Signal Ground, Analog Video Inputs
44	TMS	IN	NC	Boundary-Scan-Test Mode Select

### 3.3. Pin Descriptions

Pins 44, 1 – JTAG Input Pins, **TMS, TDI** (Fig. 3–4)  
Test Mode Select and Test Data Input signals of the JTAG Test Access Port (TAP). Both signals are inputs with a TTL compatible input specification. To comply with JTAG specification they use pull-ups at their input stage. The input stage of the TMS and TDI uses a TTL Schmitt Trigger.

Pin 2 – JTAG Input Pin, **TCK** (Fig. 3–3)  
Clock signal of the Test-Access Port. It is used to synchronize all JTAG functions. When JTAG operations are not being performed, this pin should be driven to VSS. The input stage of the TCK uses a TTL Schmitt Trigger.

Pin 3 – JTAG Output Pin, **TDO, LLC2, DACT** (Fig. 3–6)  
Data output for JTAG Test Access Port (TAP). Moreover, if Test Access Port (TAP) is in Test-Logic-Reset State, this pin can be used as output pin of the LLC2 clock signal (I<sup>2</sup>C Reg. 0xF2 bit[4] = 1) or it can be used as output pin for the active VBI-Data signal DACT (see section 2.13.).

Pins 4 to 6 – Reference Signals, **HREF, VREF, FIELD** (Fig. 3–6)  
These signals are internally generated sync signals. The state of FIELD during the positive edge of  $\overline{\text{RES}}$  selects the power up mode (see section 2.15.1.).

Pins 7 to 10, 14 to 17 – Video, **Port A[7:0]** (Fig. 3–6)  
Video output port to deliver luma and/or chroma data.

Pin 11 – Supply Voltage (Pad Circuitry), **PVDD**

Pins 12, 19 – Pixel Clock, **PIXCLK, LLC** (Fig. 3–6)  
PIXCLK and LLC are the reference clock signals for the video data transmission ports A[7:0] and B[7:0].

Pin 13 – Ground (Pad Circuitry), **PVSS**

Pin 18 – Output Enable Input Signal,  $\overline{\text{OE}}$  (Fig. 3–3)  
The output enable input signal has TTL Schmitt Trigger input characteristic. It controls the tri-state condition of both video ports. The state during the positive edge of  $\overline{\text{RES}}$  selects the I<sup>2</sup>C device address (see section 2.14.3.).

Pins 20 – Video Qualifier Output, **VACT** (Fig. 3–6)  
This pin delivers a signal which qualifies active video samples.

Pins 21 to 28 – Video, **Port B[7:0]** (Fig. 3–6)  
Video output port to deliver chroma data. In 8-bit modes, Port B can be activated as programmable output (see section 2.6.3.).

Pin 29 – I<sup>2</sup>C Bus Data, **SDA** (Fig. 3–5)  
This pin connects to the I<sup>2</sup>C bus data line.

Pin 30 – I<sup>2</sup>C Bus Clock, **SCL** (Fig. 3–5)  
This pin connects to the I<sup>2</sup>C bus clock line.

Pin 31 – Reset Input,  $\overline{\text{RES}}$  (Fig. 3–3)  
A low level on this pin resets the VPX 3225D.

Pin 32 – Ground (Digital Circuitry), **VSS**

Pin 33 – Supply Voltage (Digital Circuitry), **VDD**

Pins 34, 35 – Crystal Input and Output, **XTAL1, XTAL2** (Fig. 3–8)  
These pins are connected to a 20.25 MHz crystal oscillator which is digitally tuned by integrated shunt capacitances. An external clock can be fed into XTAL1. In this case, clock frequency adjustment must be switched off.

Pin 36 – Supply Voltage (Analog Circuitry), **AVDD**

Pin 37 – Chroma Input, **CIN** (Fig. 3–12, Fig. 3–11)  
This pin is connected to the S-VHS chroma signal. A resistive divider is used to bias the input signal to the middle of the converter input range. CIN can only be connected to the chroma (Video 2) A/D converter. The signal must be AC-coupled.

Pin 38 – Ground (Analog Front-end), **AVSS**

Pins 39, 40, 42 – Video Input 1–3, **VIN1–3** (Fig. 3–10)  
These are the analog video inputs. A CVBS, S-VHS luma signal is converted using the luma (Video 1) A/D converter. The VIN1 input can also be switched to the chroma (Video 2) ADC. The input signal must be AC-coupled.

Pin 41 – Reference Voltage Top, **VRT** (Fig. 3–9)  
Via this pin, the reference voltage for the A/D converters is decoupled. The pin is connected with 10  $\mu\text{F}$ /47 nF to the Signal Ground Pin.

Pin 43 – Ground (Analog Signal Input), **ISGND**  
This is the high-quality ground reference for the video input signals.

3.4. Pin Configuration

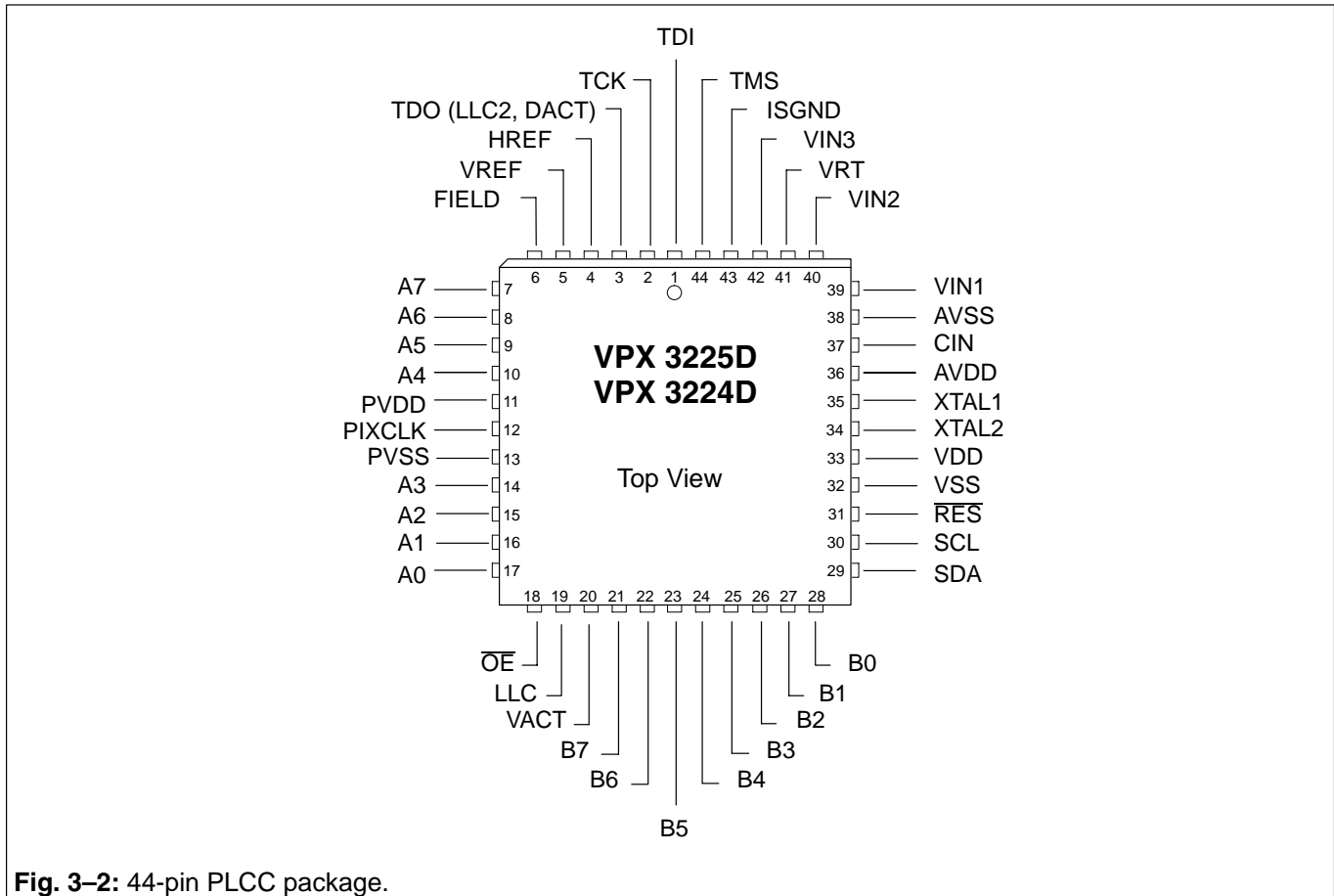


Fig. 3-2: 44-pin PLCC package.

3.5. Pin Circuits

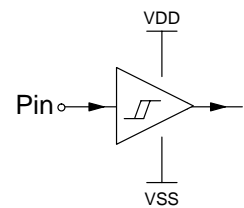


Fig. 3-3: TCK,  $\overline{OE}$ ,  $\overline{RES}$

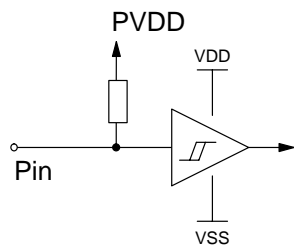


Fig. 3-4: TMS, TDI

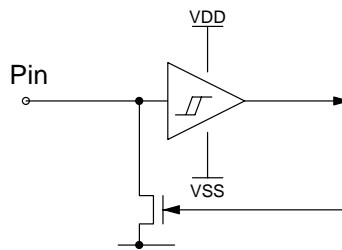


Fig. 3-5: I<sup>2</sup>C Interface SDA, SCL

The characteristics of the Schmitt Triggers are depend on the supply of VDD/VSS.

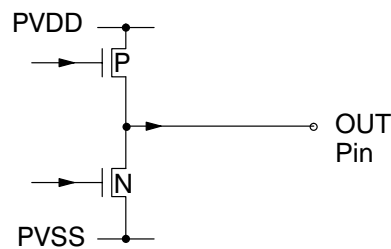
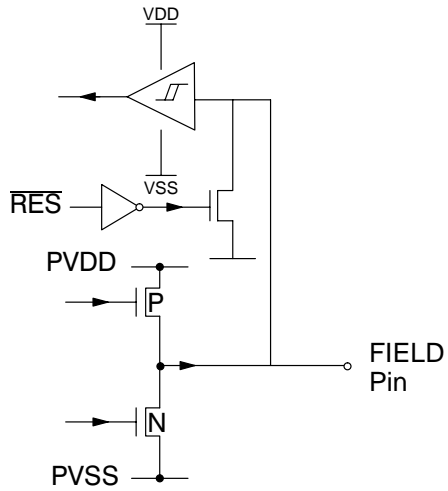
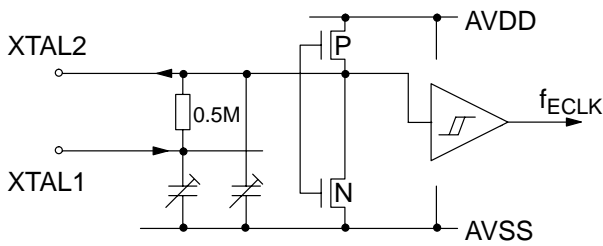


Fig. 3-6: A[7:0], B[7:0], HREF, VREF, LLC, PIXCLK, VACT, TDO

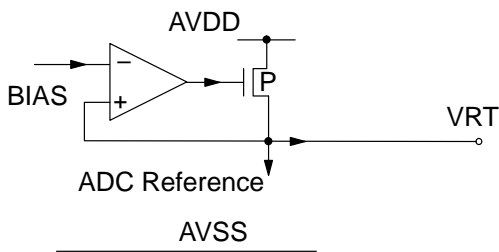




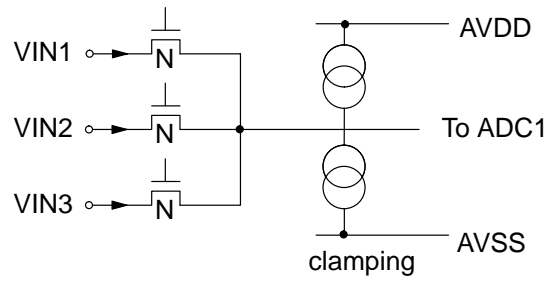
**Fig. 3-7:** Reference Signal FIELD and wake-up selection LOWPOW on positive edge of RES



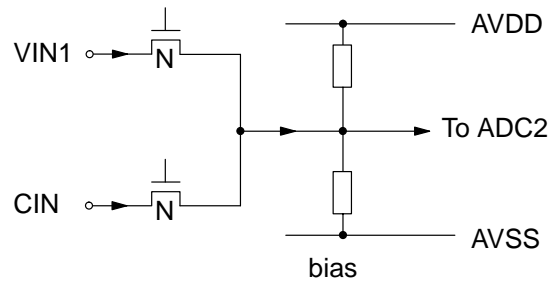
**Fig. 3-8:** Crystal Oscillator



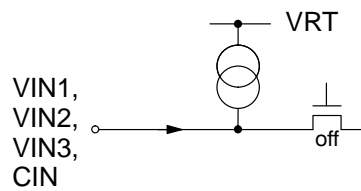
**Fig. 3-9:** Reference Voltage VRT



**Fig. 3-10:** Video Inputs ADC1



**Fig. 3-11:** Video Inputs ADC2



**Fig. 3-12:** Unselected Video Inputs

## 4. Electrical Characteristics

### 4.1. Absolute Maximum Ratings

Symbol	Parameter	Pin Name	Min.	Max.	Unit
$T_A$	Ambient Temperature		0	65	°C
$T_S$	Storage Temperature		-40	125	°C
$T_J$	Junction Temperature		0	125	°C
$V_{SUB}$	Supply Voltage, all Supply Inputs		-0.3	6	V
$P_{TOT MAX}$	Power Dissipation due to package characteristics	VDD, PVDD, AVDD		1170	mW
	Input Voltage of FIELD, TMS, TDI		PVSS - 0.5	PVDD + 0.5 <sup>1)</sup>	V
	Input Voltage	TCK	PVSS - 0.5	6	V
	Input Voltage	SDA, SCL	VSS - 0.5	6	V
	Signal Swing	A[7:0], B[7:0], PIXCLK, HREF, VREF, FIELD, VACT, LLC, TDO	PVSS - 0.5	PVDD + 0.5 <sup>1)</sup>	V
	Maximum $\Delta$   VDD - AVDD			0.5	V
	Maximum $\Delta$   VSS - PVSS   Maximum $\Delta$   VSS - AVSS   Maximum $\Delta$   PVSS - AVSS			0.1	V

<sup>1)</sup> External voltage exceeding PVDD+0.5 V should not be applied to these pins even when they are tri-stated.

Stresses beyond those listed in the “Absolute Maximum Ratings” may cause permanent damage to the device. This is a stress rating only. Functional operation of the device at these or any other conditions beyond those indicated in the “Recommended Operating Conditions/Characteristics” of this specification is not implied. Exposure to absolute maximum ratings conditions for extended periods may affect device reliability.

**4.2. Recommended Operating Conditions**

Symbol	Parameter	Pin Name	Min.	Typ.	Max.	Unit
$T_A$	Ambient Operating Temperature	–	0	–	65	°C
$V_{SUPA}$	Analog Supply Voltage	AVDD	4.75	5.0	5.25	V
$V_{SUPD}$	Digital Supply Voltage	VDD	4.75	5.0	5.25	V
$V_{SUPP}$	Pad Supply Voltage	PVDD	3.15		3.6 <sup>1)</sup>	V
$f_{XTAL}$	Clock Frequency	XTAL1/2		20.250		MHz

<sup>1)</sup> could also be connected to the 5 V supply net; but for best performance, it is recommended to connect it to 3.3 V supply (see Fig. 7–1).

**4.2.1. Recommended Analog Video Input Conditions**

Symbol	Parameter	Pin Name	Min.	Typ.	Max.	Unit
$V_{VIN}$	Analog Input Voltage	VIN1, VIN2, VIN3, CIN	0	–	3.5	V
$C_{CP}$	Input Coupling Capacitor Video Inputs	VIN1, VIN2, VIN3		680		nF
$C_{CP}$	Input Coupling Capacitor Chroma Input	CIN		1		nF
$R_{PD}$	Recommended Drive Impedance	VIN1, VIN2, VIN3, CIN		75	100	$\Omega$

**4.2.2. Recommended I<sup>2</sup>C Conditions**

(Timing diagram see Fig. 5–3 on page 61)

Symbol	Parameter	Pin Name	Min.	Typ.	Max.	Unit
V <sub>IMIL</sub>	I <sup>2</sup> C-BUS Input Low Voltage	SCL, SDA			0.3	VDD
V <sub>IMIH</sub>	I <sup>2</sup> C-BUS Input High Voltage		0.6			VDD
f <sub>SCL</sub>	I <sup>2</sup> C-BUS Frequency	SCL			100	kHz
t <sub>I2C1</sub>	I <sup>2</sup> C START Condition Setup Time	SCL, SDA	1200			ns
t <sub>I2C2</sub>	I <sup>2</sup> C STOP Condition Setup Time		1200			ns
t <sub>I2C3</sub>	I <sup>2</sup> C-Clock Low Pulse Time	SCL	5000			ns
t <sub>I2C4</sub>	I <sup>2</sup> C-Clock High Pulse Time		5000			ns
t <sub>I2C5</sub>	I <sup>2</sup> C-Data Setup Time Before Rising Edge of Clock	SCL, SDA	55			ns
t <sub>I2C6</sub>	I <sup>2</sup> C-Data Hold Time after Falling Edge of Clock		55			ns

**4.2.3. Recommended Digital Inputs Levels of  $\overline{RES}$ ,  $\overline{OE}$ , TCK, TMS, TDI**

Symbol	Parameter	Pin Name	Min.	Typ.	Max.	Unit
V <sub>IL</sub>	Input Voltage LOW	$\overline{RES}$ , $\overline{OE}$ , TCK, TMS, TDI	-0.5	0	0.8	V
V <sub>IH</sub>	Input Voltage HIGH	$\overline{RES}$ , $\overline{OE}$ , TCK	2.0	5	6	V
V <sub>IH</sub>	Input Voltage HIGH	TDI, TMS	2.0	PVDD	PVDD + 0.3	V

**4.2.4. Recommended Crystal Characteristics**

Symbol	Parameter	Min.	Typ.	Max.	Unit
$T_A$	Operating Ambient Temperature	0	–	65	°C
$f_P$	Parallel Resonance Frequency with Load Capacitance $C_L = 13 \text{ pF}$	–	20.250000 fundamental	–	MHz
$\Delta f_P/f_P$	Accuracy of Adjustment	–	–	$\pm 20$	ppm
$\Delta f_P/f_P$	Frequency Temperature Drift	–	–	$\pm 30$	ppm
$R_R$	Series Resistance	–	–	25	$\Omega$
$C_0$	Shunt Capacitance	3	–	7	pF
$C_1$	Motional Capacitance	20	–	30	fF
<b>Load Capacitance Recommendation</b>					
$C_{Lext}$	External Load Capacitance <sup>1)</sup> from pins to Ground (PLCC44) (pin names: Xtal1 Xtal2)	–	4.7	–	pF
<b>DCO Characteristics<sup>2)</sup></b>					
$C_{ICLoadmin}$	Effective Load Capacitance @ min. DCO-Position, Code 0, package: PLCC44	3	4.3	5.5	pF
$C_{ICLoadrng}$	Effective Load Capacitance Range, DCO Codes from 0..255	8.7	12.7	16.7	pF
<p><b>1) Remarks on defining the External Load Capacitance:</b>            External capacitors at each crystal pin to ground are required. They are necessary to tune the effective load capacitance of the PCBs to the required load capacitance (<math>C_L</math>) of the crystal. The higher the capacitors, the lower the clock frequency results. The nominal free running frequency should match <math>f_p = 20.25 \text{ MHz}</math>. Due to different layouts of customer PCBs, the matching capacitor size should be determined in the application. The suggested value is a figure based on experience with various PCB layouts.            Tuning condition: Code DVCO Register = –720</p>					
<p><b>2) Remarks on Pulling Range of DCO:</b>            The pulling range of the DCO is a function of the used crystal and effective load capacitance of the IC (<math>C_{ICLoad} + C_{LoadBoard}</math>). The resulting frequency (<math>f_L</math>) with an effective load capacitance of <math>C_{Leff} = C_{ICLoad} + C_{LoadBoard}</math> is</p> $f_L = f_P * \frac{1 + 0.5 * [ C_1 / (C_0 + C_L) ]}{1 + 0.5 * [ C_1 / (C_0 + C_{Leff} ) ]}$					
<p><b>3) Remarks on DCO Codes:</b>            The DCO hardware register has 8 bits; the FP control register uses a range of –2048...2047.</p>					

### 4.3. Characteristics

at  $T_A = 0$  to  $65$  °C,  $V_{SUPD/A} = 4.75$  to  $5.25$  V,  $V_{SUPP} = 3.15$  to  $3.5$  V,  $f = 20.25$  MHz for min./max. values  
 at  $T_C = 60$  °C,  $V_{SUPD/A} = 5$  V,  $V_{SUPP} = 3.3$  V,  $f = 20.25$  MHz for typical values

#### 4.3.1. Current Consumption

Symbol	Parameter	Pin Name	Min.	Typ.	Max.	Unit
$I_{VSUPA}$	Current Consumption	AVDD	25	40	53	mA
$I_{VSUPD}$	Current Consumption	VDD	80	100	135	mA
$I_{VSUPP}$	Current Consumption	PVDD	–	–	application dependent 45@3.3V 75@5V	mA
$P_{TOT}$	Total Power Dissipation, normal operation condition	AVDD, VDD, PVDD		0.95		W
$P_{TOT}$	Total Power Dissipation, low power mode	AVDD, VDD, PVDD		0.1		W

#### 4.3.2. Characteristics, Reset

Symbol	Parameter	Min.	Typ.	Max.	Unit	Test Conditions
$t_{RES\ MIN}$	$\overline{RES}$ Low Pulse to initiate an internal reset	50			ns	xtal osc. is working
$t_{RES\ INT}$	Internal Reset Hold Time	3.2			$\mu$ s	xtal osc. is working
Default Wake-up Selection (see timing diagram in section 5.1. on page 60)						
$t_{RES\ MIN}$	$\overline{RES}$ Low Pulse due to the time needed to discharge pin FIELD by the internal pull-down transistor for default selection (see schematic of fig. 3–7)	1			ms	xtal osc. is working $C_{LOAD} (FIELD) < 50$ pF $I_{leak} < 10$ $\mu$ A
$t_{s-WU}$	Setup Time of pin FIELD and $\overline{OE}$ to posedge of $\overline{RES}$	20			ns	
$t_{h-WU}$	Hold Time of pin FIELD and $\overline{OE}$ to posedge of $\overline{RES}$	20			ns	
$I_{PD}$	Pull-down current during $\overline{RES} = 0$ at pin FIELD	42	75	68	$\mu$ A	$V_{FIELD} = 5V$
$R_{PU}$	Recommended Pull-up resistor to enforce a logical 1 to pin FIELD		10		k $\Omega$	

#### 4.3.3. XTAL Input Characteristics

Symbol	Parameter	Min.	Typ.	Max.	Unit	Test Conditions
$V_I$	Clock Input Voltage, XTAL1	1.3			$V_{PP}$	capacitive coupling of XTAL1, XTAL 2 remains open
$t_{Startup1}$	Oscillator Startup Time at VDD Slew-rate of 1 V / 1 $\mu$ s (see section 5.1. on page 60)		0.4	1.0	ms	
$t_{Startup2}$	Reset Hold Time after the Oscillator is active (see section 5.1. on page 60)	5.0			$\mu$ s	
$k_{XTAL}$	Duty Cycle		50		%	

## 4.3.4. Characteristics, Analog Front-End and ADCs

Symbol	Parameter	Pin Name	Min.	Typ.	Max.	Unit	Test Conditions
V <sub>VRT</sub>	Reference Voltage Top	VRT	2.5	2.61	2.72	V	10 μF//10 nF, 1 GΩ Probe
<b>Luma – Path</b>							
R <sub>VIN</sub>	Input Resistance	VIN1, VIN2, VIN3	1			MΩ	Code clamp – DAC = 0
C <sub>VIN</sub>	Input Capacitance			5		pF	
V <sub>VIN</sub>	Full Scale Input Voltage		1.86	1.93	2.0	V <sub>PP</sub>	min. AGC Gain
V <sub>VIN</sub>	Full Scale Input Voltage		0.5	0.6	0.7	V <sub>PP</sub>	max. AGC Gain
AGC	AGC step width		0.145	0.163	0.181	dB	6-bit resolution = 63 Steps f <sub>sig</sub> = 1 MHz, – 2 dBr of max. AGC Gain
DNL <sub>AGC</sub>	AGC Differential Non-Linearity				±0.5	LSB	
V <sub>VINCL</sub>	Input Clamping Level, CVBS			1.0		V	Binary Level = 68 LSB min. AGC Gain
Q <sub>CL</sub>	Clamping DAC Resolution		–16		15	steps	6 Bit – I–DAC, bipolar V <sub>VIN</sub> = 1.5 V
I <sub>CL–LSB</sub>	Input Clamping Current per step		0.7	1	1.3	μA	
DNL <sub>ICL</sub>	Clamping DAC Differential Non-Linearity				±0.5	LSB	
<b>Chroma – Path</b>							
R <sub>CIN</sub>	Input Resistance SVHS Chroma	CIN, VIN1	1.4	2.0	2.6	kΩ	
C <sub>VIN</sub>	Input Capacitance	CIN, VIN1		5		pF	
V <sub>CIN</sub>	Full Scale Input Voltage, Chroma	CIN, VIN1	1.08	1.14	1.2	V <sub>PP</sub>	
V <sub>CINDC</sub>	Input Bias Level, SVHS Chroma		–	1.5	–	V	
	Binary Code for Open Chroma Input			128			
<b>Dynamic Characteristics for all Video-Paths (Luma + Chroma)</b>							
BW	Bandwidth	VIN1, VIN2, VIN3, CIN	10	14		MHz	–2 dBr input signal level
XTALK	Crosstalk, any two video inputs			–56	–48	dB	1 MHz, –2 dBr signal level
THD	Total Harmonic Distortion			–48	–45	dB	1 MHz, 5 harmonics, –2 dBr signal level
SINAD	Signal to Noise and Distortion Ratio		42	46		dB	1 MHz, all outputs, –2 dBr signal level
INL	Integral Non-Linearity,			±1.3	±2.4	LSB	Code Density, DC-ramp
DNL	Differential Non-Linearity			±0.5	±0.85	LSB	
DG	Differential Gain				±3	%	–12 dBr, 4.4 MHz signal on DC-Ramp
DP	Differential Phase				1.5	deg	

**4.3.5. Characteristics, Control Bus Interface**

(Timing diagram see Fig. 5–3 on page 61)

Symbol	Parameter	Pin Name	Min.	Typ.	Max.	Unit	Test Conditions
$V_{IMOL}$	Output Low Voltage	SDA, SCL	–	–	0.4 0.6	V V	$I_I = 3\text{ mA}$ $I_I = 6\text{ mA}$
$t_{IMOL1}$	I <sup>2</sup> C-Data Output Hold Time after Falling Edge of Clock SCL	SDA	15			ns	
$t_{IMOL2}$	I <sup>2</sup> C-Data Output Setup Time before Rising Edge of Clock SCL	SDA	100			ns	$f_{SCL} = 1\text{ MHz}$ , $V_{DD} = 5\text{ V}$
$t_F$	Signal Fall Time	SDA, SCL	–	–	300	ns	$C_L = 400\text{ pF}$ , $R_{PU} = 4,7\text{ k}$
$f_{SCL}$	Clock Frequency <sup>1)</sup>	SCL	0	–	100 1000	kHz kHz	low power mode normal operating condition

<sup>1)</sup> The maximum clock frequency of the I2C interface is limited to 100 kHz while the IC is working in the low power mode.

**4.3.6. Characteristics, JTAG Interface (Test Access Port TAP)**

(Timing diagram see Fig. 5–5 on page 63)

Symbol	Parameter	Min.	Typ.	Max.	Unit	Test Conditions
$\Phi_{CYCL-TAP}$	JTAG Cycle Time	100			ns	
$\Phi_{H-TAP}$	TCK High Time	50			ns	
$\Phi_{L-TAP}$	TCK Low Time	50			ns	
$V_{RES-TAP}$	Minimum supply voltage to initiate an internal reset of the JTAG-TAP generated by a voltage supply supervision circuit	3.5			V	VDD pin
Test Access Port (TAP), see timing diagram (Fig. 5–5 on page 63)						
$t_{S-TAP}$	TMS, TDI Setup Time	12			ns	
$t_{H-TAP}$	TMS, TDI Hold Time	12			ns	
$t_{D-TAP}$	TCK to TDO Propagation Delay for Valid Data			50	ns	
$t_{ON-TAP}$	TDO Turn-on Delay			45	ns	
$t_{OFF-TAP}$	TDO Turn-off Delay			45	ns	
Boundary-Scan Test, Characteristics of all IO pins which are connected to the boundary scan register chain						
$t_{S-PINS}$	Input Signals Setup Time at CAPTURE-DR	10			ns	
$t_{H-PINS}$	Input Signals Hold Time at CAPTURE-DR	10			ns	
$t_{D-PINS}$	TCK to Output Signals, Delay for Valid Data			50	ns	
$t_{ON-PINS}$	Turn-on Delay			20	ns	
$t_{OFF-PINS}$	Turn-off Delay			20	ns	



### 4.3.7. Characteristics, Digital Inputs/Outputs

Symbol	Parameter	Min.	Typ.	Max.	Unit	Test Conditions
Digital Input Pins TMS, TDI, TCK, RES, OE, SCL, SDA						
C <sub>IN</sub>	Input Capacitance		5	8	pF	
I <sub>I</sub>	Input Leakage Current Input Pins TCK, RES, OE, SCL, SDA			-1 +1	μA	V <sub>I</sub> = V <sub>SS</sub> V <sub>I</sub> ≤ V <sub>DD</sub>
I <sub>I</sub>	Input Leakage Current Input Pins with Pull-ups: TDI and TMS		-25	-55 +1	μA	V <sub>I</sub> = V <sub>SS</sub> V <sub>I</sub> ≤ V <sub>DD</sub>
I <sub>PD</sub>	Pull-down Current at Pin FIELD during RES = 0 for Default Selection	see section 4.3.2.				
Digital Output pins A[7:0], B[7:0], HREF, VREF, FIELD, VACT, LLC, PIXCLK, TDO						
C <sub>O</sub>	High-Impedance Output Capacitance		5	8	pF	
V <sub>OL</sub>	Output Voltage LOW (all digital output pins except SDA, SCL)			0.6	V	
V <sub>OL</sub>	Output Voltage LOW (only SDA, SCL)			0.4 0.6	V V	I <sub>I</sub> = 3 mA I <sub>I</sub> = 6 mA
V <sub>OH</sub>	Output Voltage HIGH (all digital output pins except SDA, SCL)	2.4	-	PVDD	V	
I <sub>O</sub>	Output Leakage Current			-1 +1	μA μA	while IC remains in low power mode V <sub>I</sub> = V <sub>SS</sub> V <sub>I</sub> ≤ V <sub>DD</sub>
A special VDD, VSS supply is used only to support the digital output pins. This means, inherently, that in case of tri-state conditions, external sources should not drive these signals above the voltage PVDD which supplies the output pins.						

### 4.3.8. Clock Signals PIXCLK, LLC, and LLC2

The following timing specifications refer to the timing diagrams of section 5.7.1. on page 64.

Symbol	Parameter	Min.	Typ.	Max.	Unit	Test Conditions
t <sub>LLC</sub>	LLC Cycle Time		37		ns	
Φ <sub>LLC</sub>	LLC Duty Cycle Φ <sub>H</sub> / (Φ <sub>L</sub> + Φ <sub>H</sub> )		50		%	
t <sub>LLC2</sub>	LLC2 Cycle Time		74		ns	
Φ <sub>LLC2</sub>	LLC2 Duty Cycle Φ <sub>H</sub> / (Φ <sub>L</sub> + Φ <sub>H</sub> )		50		%	
t <sub>PIXCLK</sub>	PIXCLK Cycle Time		74		ns	
Φ <sub>PIXCLK</sub>	PIXCLK Duty Cycle Φ <sub>H</sub> / (Φ <sub>L</sub> + Φ <sub>H</sub> )		50		%	
t <sub>HCLK1</sub>	Output Signal Hold Time for LLC2	0			ns	
t <sub>DCLK1</sub>	Propagation Delay for LLC2			10	ns	
t <sub>HCLK2</sub>	Output Signal Hold Time for PIXCLK	10			ns	
t <sub>DCLK2</sub>	Propagation Delay for PIXCLK			18	ns	

## 4.3.9. Digital Video Interface

Symbol	Parameter	Min.	Typ.	Max.	Unit	Test Conditions
<b>Data and Control Pins (LLC to A[7:0], B[7:0], HREF, VREF, FIELD, VACT):</b> The following timing specifications refer to the timing diagrams of section 5.7. on page 64.						
t <sub>OH</sub>	Output Hold Time	20			ns	I <sup>2</sup> C Reg. h'AA –bit[6]=1
t <sub>PD</sub>	Propagation Delay			35	ns	
New LLC output timing (available starting version D4)						
t <sub>OH</sub>	Output Hold Time	8			ns	I <sup>2</sup> C Reg. h'AA –bit[6]=0
t <sub>PD</sub>	Propagation Delay			23	ns	
Output Enable by $\overline{OE}$ (For more information, see section 5.4. on page 62)						
t <sub>ON</sub>	Output Enable $\overline{OE}$ of A[7:0], B[7:0]			15	ns	
t <sub>OFF</sub>	Output Disable $\overline{OE}$ of A[7:0], B[7:0]			15	ns	
t <sub>ON1</sub>	Output Enable $\overline{OE}$ of A[7:0], B[7:0]			5	ns	
t <sub>OFF1</sub>	Output Disable $\overline{OE}$ of A[7:0], B[7:0]			5	ns	
$\overline{OE}$ input timing						
t <sub>SU</sub>	input data set-up time	11			ns	
t <sub>HD</sub>	input data hold time	3			ns	

## 4.3.10. Characteristics, TTL Output Driver

Output Pins A[7:0], B[7:0], PIXCLK, LLC, VACT, HREF, VREF, FIELD, TDO/LLC2

Symbol	Parameter	Min.	Typ.	Max.	Unit	Test Conditions
t <sub>RA</sub>	Rise Time	2	5	10	ns	C <sub>1</sub> = 30 pF, strength = 4
t <sub>FA</sub>	Fall Time	2	5	10	ns	C <sub>1</sub> = 30 pF, strength = 4
I <sub>OH(0)</sub>	Output High Current (strength = 0)	-1.37	-2.25	-2.87	mA	V <sub>OH</sub> = 0.6 V
I <sub>OL(0)</sub>	Output Low Current (strength = 0)	1.75	3.5	4.5	mA	V <sub>OH</sub> = 2.4 V
I <sub>OH(7)</sub>	Output High Current (strength = 7)	-11	-18	-25	mA	V <sub>OH</sub> = 0.6 V
I <sub>OL(7)</sub>	Output Low Current (strength = 7)	14	28	36	mA	V <sub>OH</sub> = 2.4 V

#### 4.3.10.1. TTL Output Driver Description

The driving capability/strength is controlled by the state of the two I<sup>2</sup>C registers F8<sub>hex</sub> and F9<sub>hex</sub>.

A special PVDD, PVSS supply is used only to support the digital output pins. This means, inherently, that in case of tri-state conditions, external sources should not drive these signals above the voltage PVDD which supplies the output pins.

All timing specifications are based on the following assumptions:

- the load capacitance of the fast pins (output driver type A) is  $C_A = 30$  pF,
- the load capacitance of the remaining pins (output driver type B) is  $C_B = 50$  pF,
- no static currents are assumed,
- the driving capability of the pads is  $STR = 4$ , which means that 5 of 8 output drivers are enabled.

The typical case specification relates to:

- the ambient temperature is  $T_A = 25$  °C, which relates to a junction temperature of  $T_J = 70$  °C;
- the power supply of the pad circuits is  $PVDD = 3.3$  V, and the power supply of the digital parts is  $VDD = 5.0$  V.

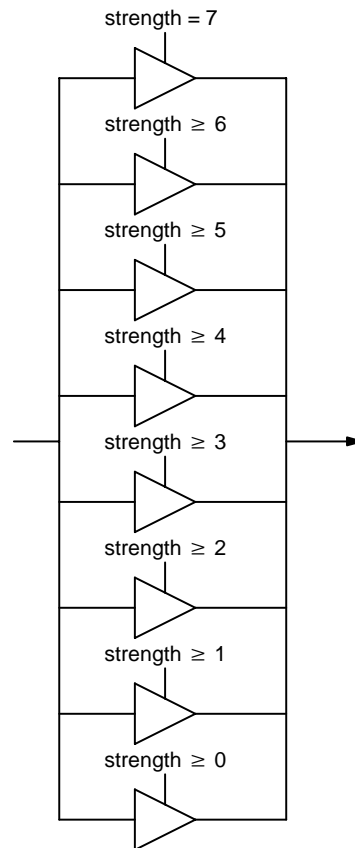
The best case specification relates to:

- a junction temperature of  $T_J = 0$  °C,
- the power supply of the pad circuits is  $PVDD = 3.6$  V, and the power supply of the digital parts is  $VDD = 5.25$  V.

The worst case specification relates to:

- a junction temperature of  $T_J = 125$  °C,
- the power supply of the pad circuits is  $PVDD = 3.0$  V, and the power supply of the digital parts is  $VDD = 4.75$  V.

Rise times are specified as a transition between 0.6 V to 2.4 V. Fall times are defined as a transition between 2.4 V to 0.6 V.



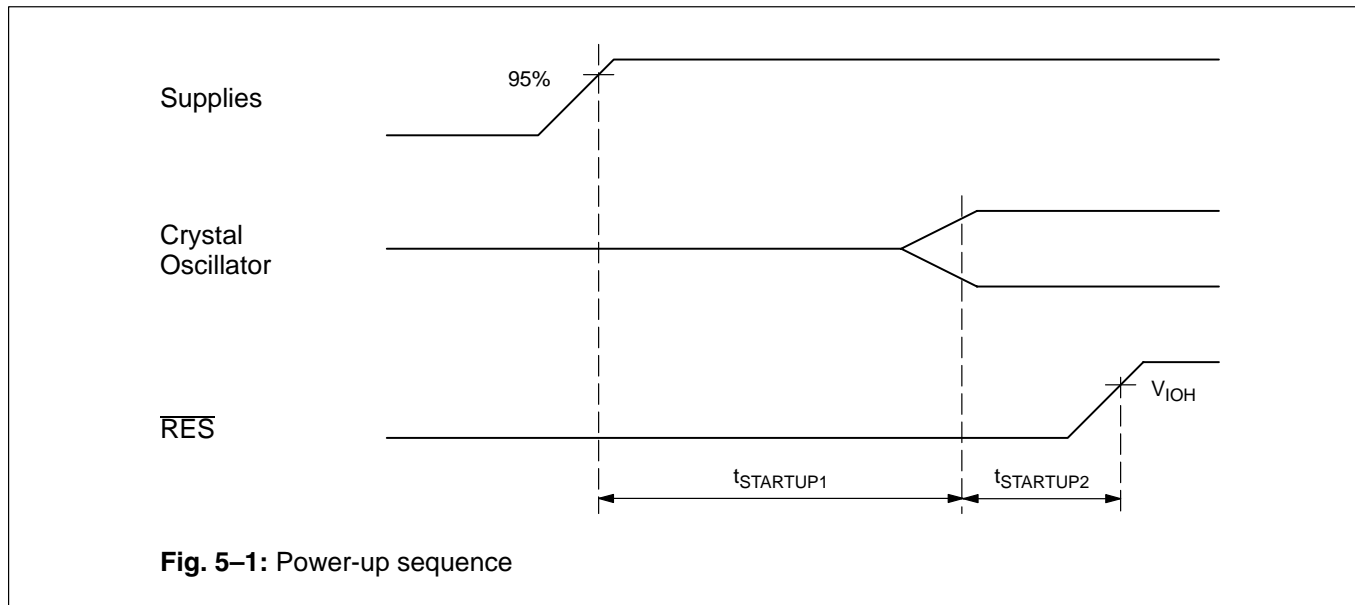
**Fig. 4-1:** Block diagram of the output stages

**Note:** The drivers of the output pads are implemented as a parallel connection of 8 tri-state buffers of the same size. The buffers are enabled depending on the desired driver strength. This opportunity offers the advantage of adapting the driver strength to on-chip and off-chip constraints, e.g. to minimize the noise resulting from steep signal transitions.

5. Timing Diagrams

5.1. Power-Up Sequence

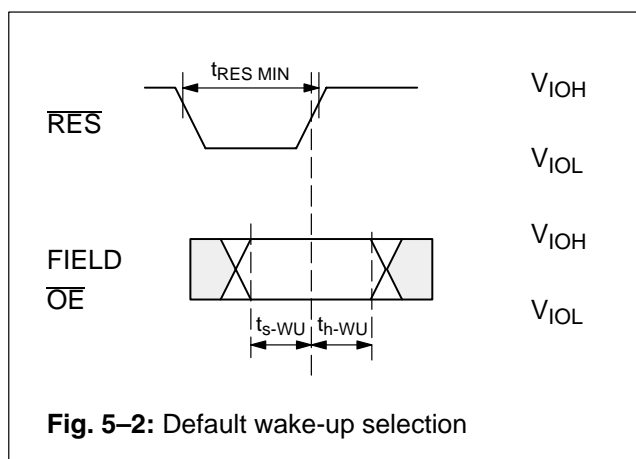
The reset should not reach high level before the oscillator has started. This requires a reset delay of >1 ms (see Fig.5-1).



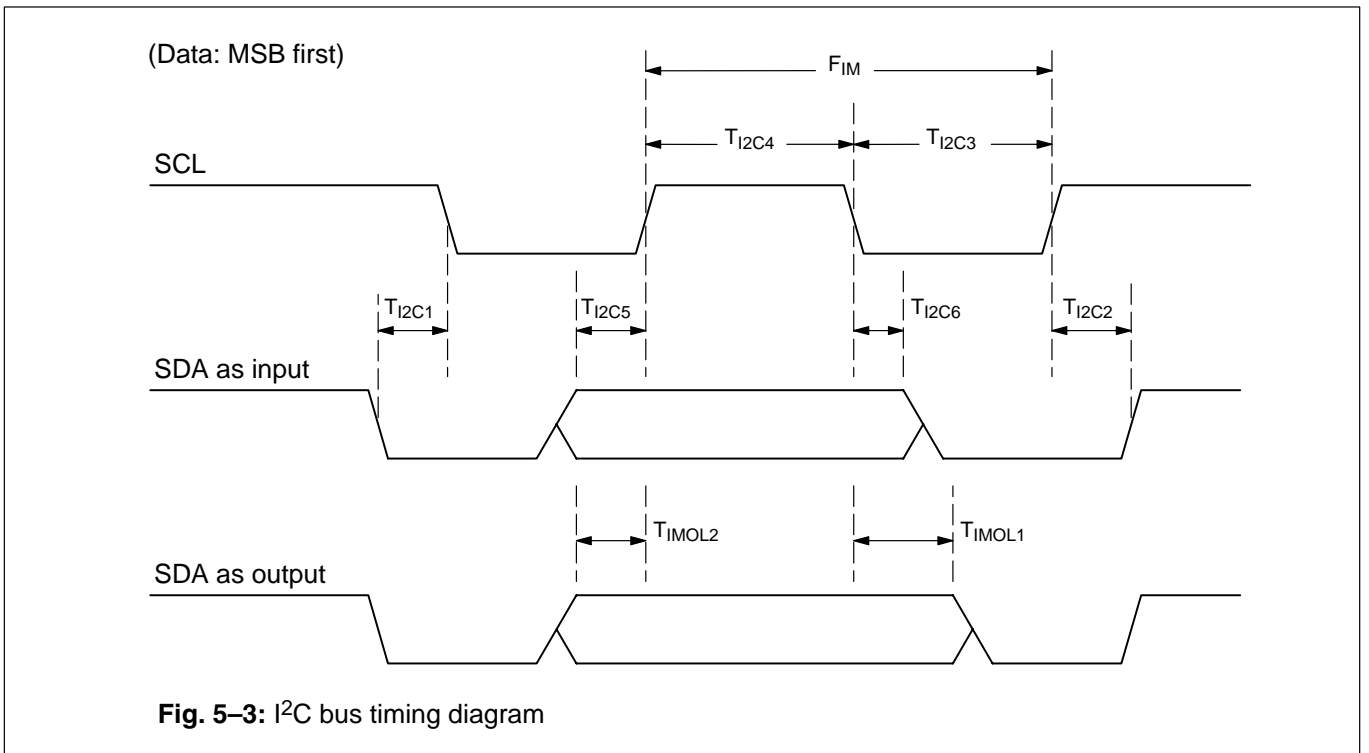
5.2. Default Wake-up Selection

The state of FIELD and  $\overline{OE}$  pins are sampled at the high (inactive) going edge of  $\overline{RES}$  in order to select between two power-on parameters.  $\overline{OE}$  determines the I<sup>2</sup>C address.

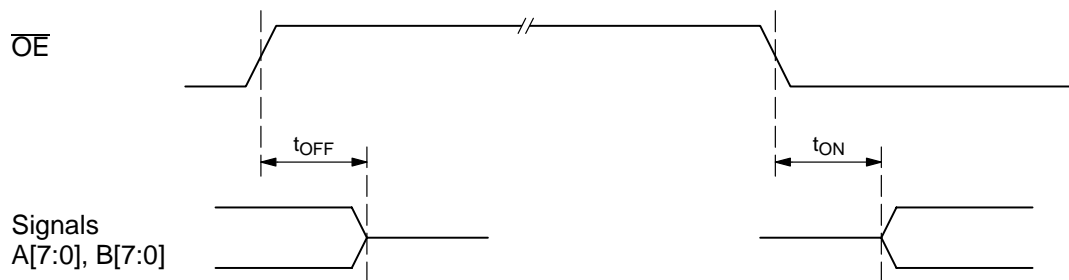
The FIELD pin is internally pulled down. An external pull-up resistor defines a different power on configuration. FIELD defines the global wake-up mode of the VPX. With FIELD pulled down, the VPX goes into low power mode.



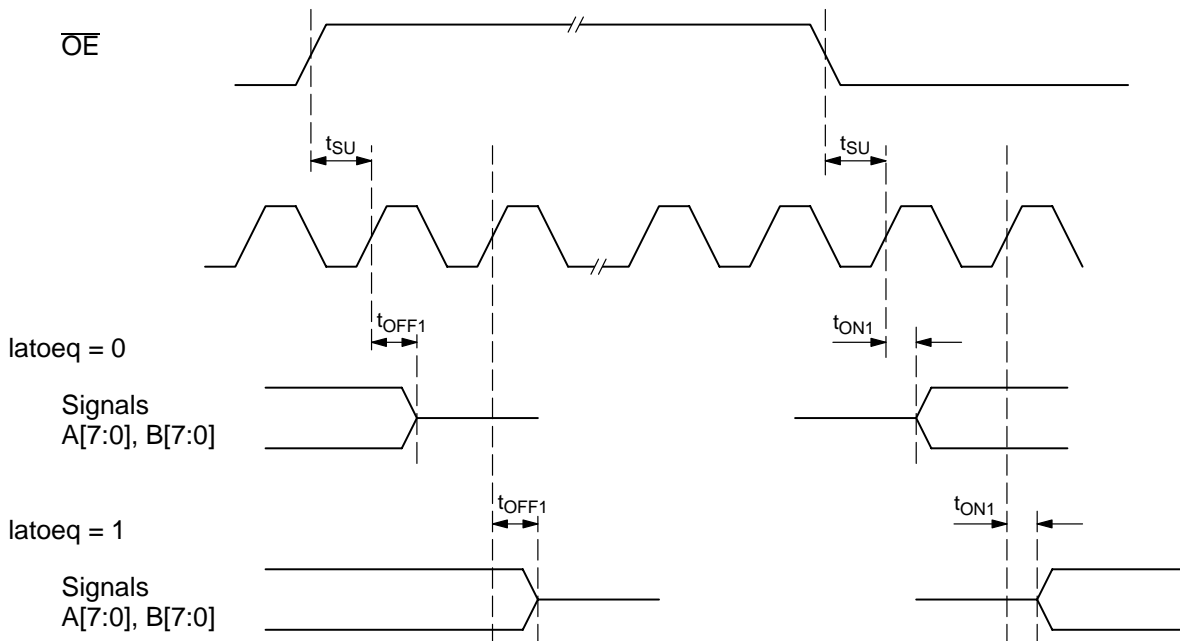
5.3. Control Bus Timing Diagram



5.4. Output Enable by Pin  $\overline{OE}$

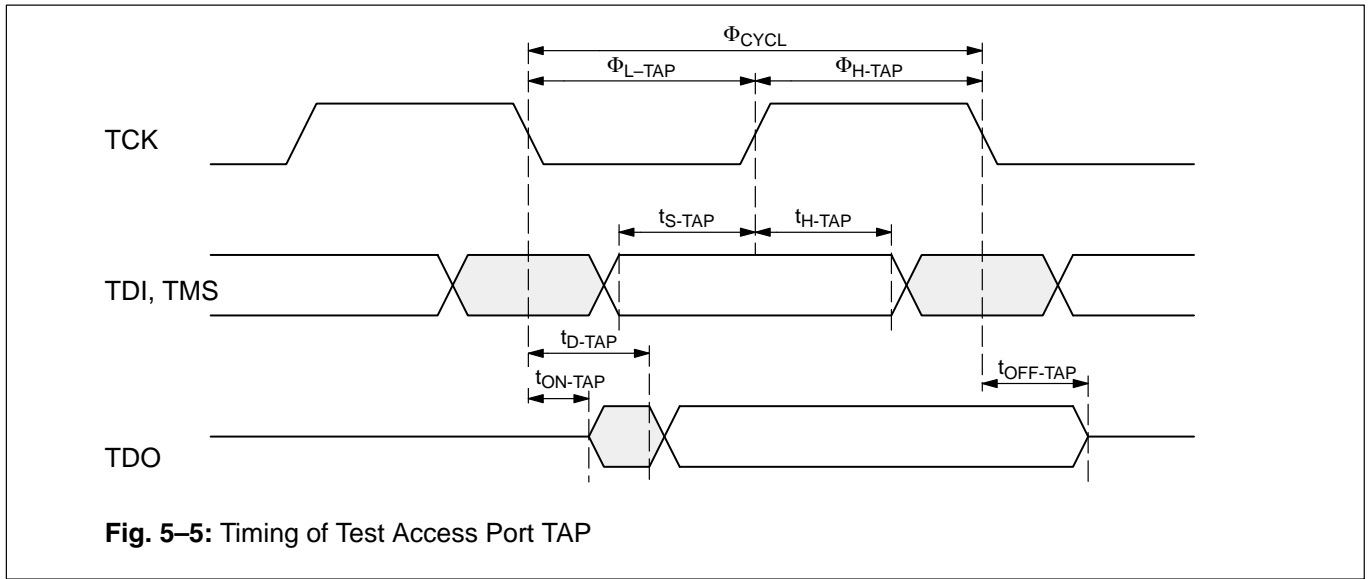


Synchronizing the  $\overline{OE}$  signal with clock LLC:  
 controlled by I<sup>2</sup>C register 'OENA' h'f2 bit[5] oeqdel = 1

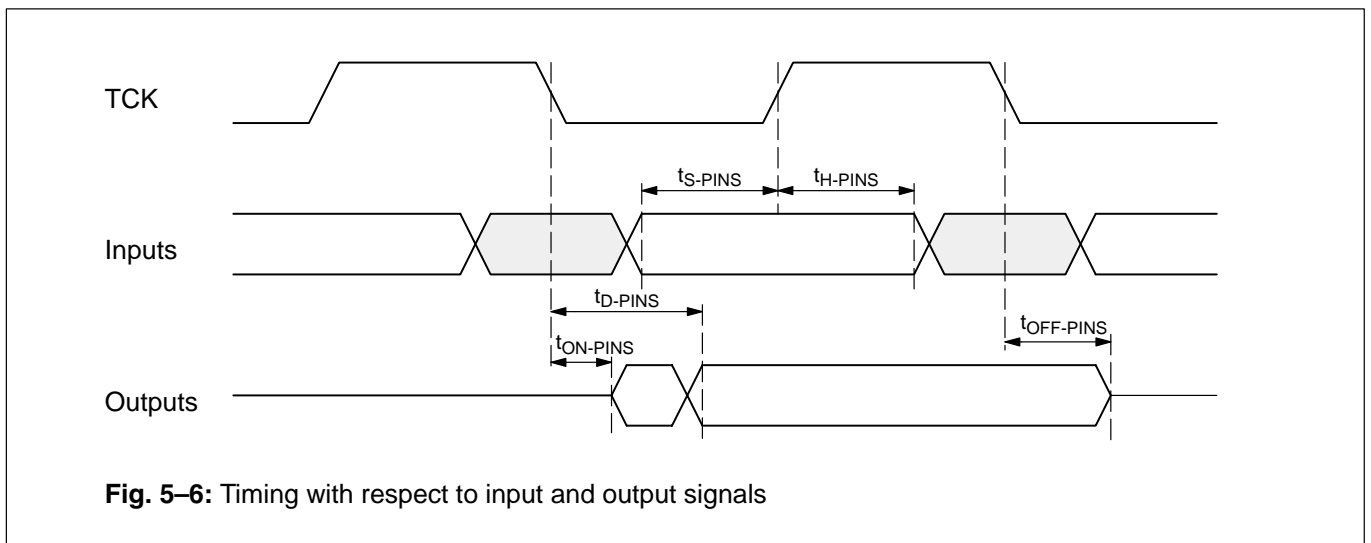


**Fig. 5-4:** Drive Control by  $\overline{OE}$  input

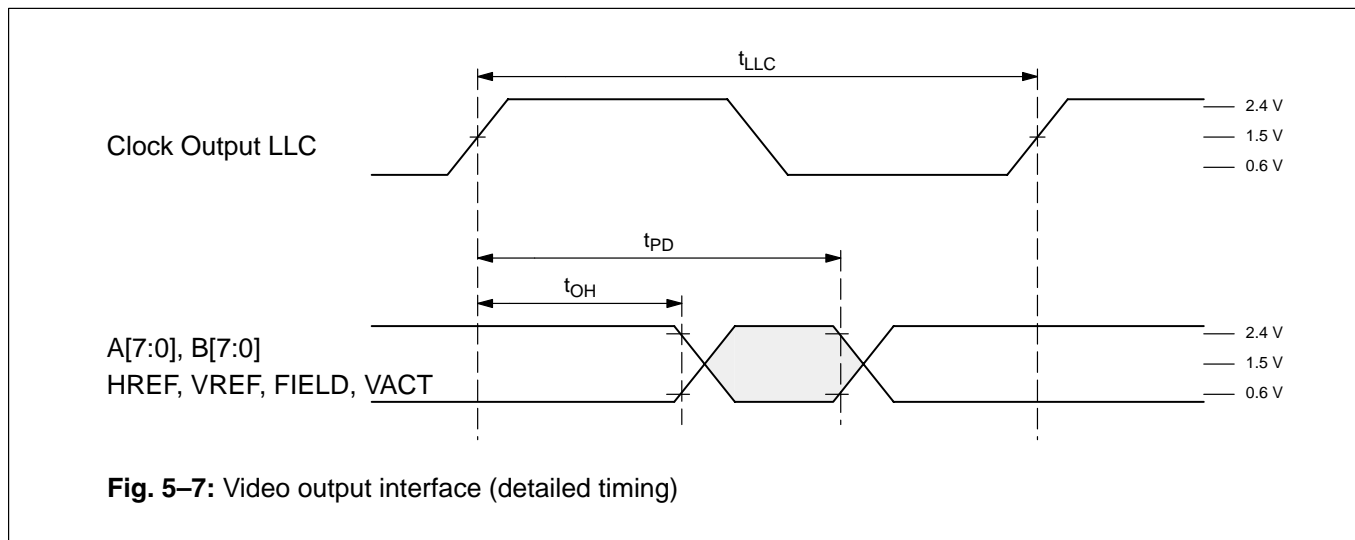
5.5. Timing of the Test Access Port TAP



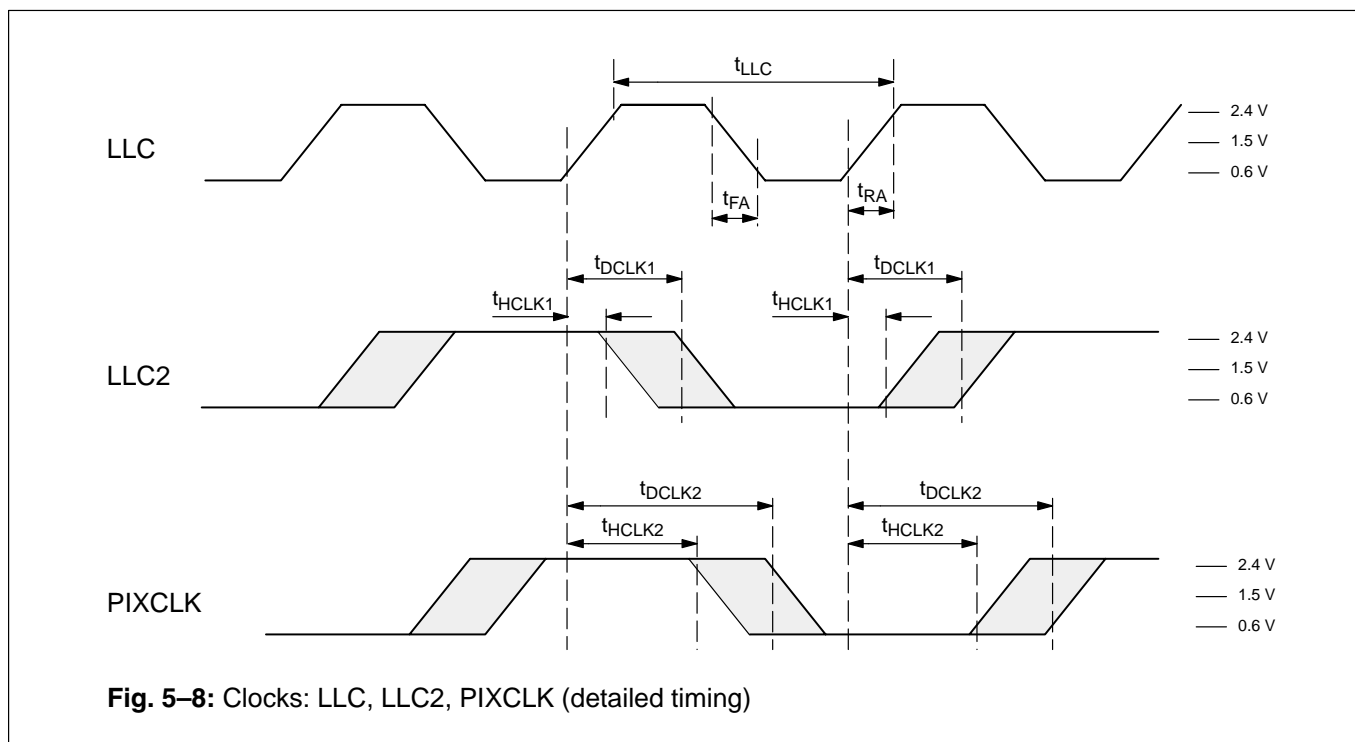
5.6. Timing of all Pins connected to the Boundary-Scan-Register-Chain



5.7. Timing Diagram of the Digital Video Interface



5.7.1. Characteristics, Clock Signals





## 6. Control and Status Registers

The following tables give definitions for the VPX control and status registers. The number of bits indicated for each register in the table is the number of bits implemented in the hardware, i.e. a 9-bit register must always be accessed using two data bytes, but the 7 MSB will be “0” on write operations and don’t care on read operations. Write registers that can be read back are indicated in the mode column.

The control register modes are

- w write-only register
- r read-only register
- w/r write/read register
- d register is double latched
- v register is latched with vsync

Default values are initialized at reset. The mnemonics used in the Micronas VPX demo software are given in the last column.

### 6.1. Overview

I <sup>2</sup> C-Registers					
Address Hex	Number of Bits	Mode	Function	Group	Name
h'00	8	r	Manufacture ID	Chip Ident.	JEDEC
h'01 h'02	8 8	r	16-bit part number	Chip Ident.	PARTNUM
h'03	8	r	JEDEC2	Chip Ident.	JEDEC2
h'35	8	r	FP status	FP Interface	FPSTA
h'36	16	w	FP read	FP Interface	FPRD
h'37	16	w	FP write	FP Interface	FPWR
h'38	16	w/r	FP data	FP Interface	FPDAT
h'AA	8	w	Low power mode, LLC mode	Output	llc
h'B3	8	r	soft error counter	Byte Slicer	softerrcnt
h'B4	8	r	sync status	Sync Slicer	sync_stat
h'B5	8	r	hsync counter	Sync Slicer	sync_cnt
h'B6	8	r	read filter coefficient	Bit Slicer	coeff_rd
h'B7	8	r	read data slicer level	Bit Slicer	level_rd
h'B8 h'B9 h'BA	8 8 8	w w w	clock run-in and framing code don't care mask high clock run-in and framing code don't care mask mid clock run-in and framing code don't care mask low	Byte Slicer	mask
h'BB h'BC h'BD	8 8 8	w w w	clock run-in and framing code reference high clock run-in and framing code reference mid clock run-in and framing code reference low	Byte Slicer	reference
h'C0	8	w	soft slicer level	Bit Slicer	soft_slicer
h'C1 h'C2	8 8	w w	tx bitslicer frequency LSB tx bitslicer frequency MSB	Bit Slicer	tx_freq
h'C5	8	w	filter coefficient	Bit Slicer	coeff
h'C6	8	w	data slicer level	Bit Slicer	data_slicer
h'C7	8	w	accumulator mode	Bit Slicer	accu
h'C8	8	w	sync slicer level	Sync Slicer	sync_slicer
h'C9	8	w	standard	Byte Slicer	standard
h'CE	8	w	bit error tolerance	Byte Slicer	tolerance
h'CF	8	w	byte count	Byte Slicer	byte_cnt
h'F2	8	w	Output Enable	Output	oena
h'F8	8	w	Pad Driver Strength – TTL Output Pads Type A	Output	driver_a
h'F9	8	w	Pad Driver Strength – TTL Output Pads Type B	Output	driver_b

FP-RAM					
Address Hex	Number of Bits	Mode	Function	Group	Name
h'12	12	r/w	general purpose control	Status	gp_ctrl
h'13	12	r	standard recognition status	Status	asr
h'15	12	r	vertical field counter	Status	vcnt
h'20	12	w	Standard select	Stand. Sel.	sdt
h'21	12	w	Input select	Stand. Sel.	insel
h'22	12	w	start point of active video	Stand. Sel.	sfif
h'23	12	w	luma/chroma delay adjust	Stand. Sel.	ldly
h'30	12	w	ACC reference level to adjust C <sub>r</sub> , C <sub>b</sub> levels on picture bus	Color Proc.	accref
h'31	12	r	measured burst amplitude	Status	bampl
h'32	12	w	ACC multiplier value for SECAM Db chroma comp. to adjust C <sub>b</sub> on pict. bus	Color Proc.	accb
h'33	12	w	ACC multiplier value for SECAM Dr chroma comp. to adjust C <sub>r</sub> on pict. bus	Color Proc.	accr
h'39	12	w	amplitude killer level	Color Proc.	kilvl
h'3A	12	w	amplitude killer hysteresis	Color Proc.	kilhy
h'74	12	r	measured sync amplitude value	Status	sampl
h'CB	12	r	number of lines per field, P/S: 312, N: 262	Status	nlpf
h'DC	12	w	NTSC tint angle, $\pm 512 = \pm \pi/4$	Color Proc.	tint
h'F0	12	r	software version number	Status	version
h'F7	12	w/r	crystal oscillator line-locked mode,	DVCO	xlck
h'F8	12	w	crystal oscillator center frequency adjust	DVCO	dvco
h'F9	12	r	crystal oscillator center frequency adjustment value	DVCO	adjust
h'10F	12	r	Delay of VACT relative to HREF during window 1	ReadTab1	vact_dly1
h'11F	12	r	Delay of VACT relative to HREF during window 2	ReadTab2	vact_dly2
h'120	12	w	Vertical Begin	WinLoadTab1	vbegin1
h'121	12	w	Vertical Lines In / Temporal Decimation / Field Select	WinLoadTab1	vlinesin1
h'122	12	w	Vertical Lines Out	WinLoadTab1	vlinesout1
h'123	12	w	Horizontal Begin	WinLoadTab1	hbeg1
h'124	12	w	Horizontal Length	WinLoadTab1	hlen1
h'125	12	w	Number of Pixels	WinLoadTab1	npix1
h'126	12	w	Selection for peaking / coring	WinLoadTab1	peaking1
h'127	12	w	Brightness	WinLoadTab1	brightness1
h'128	12	w	Contrast / Noise shaping / Clamping	WinLoadTab1	contrast1
h'12A	12	w	Vertical Begin	WinLoadTab2	vbegin2
h'12B	12	w	Vertical Lines In	WinLoadTab2	vlinesin2
h'12C	12	w	Vertical Lines Out	WinLoadTab2	vlinesout2
h'12D	12	w	Horizontal Begin	WinLoadTab2	hbeg2
h'12E	12	w	Horizontal Length	WinLoadTab2	hlen2
h'12F	12	w	Number of Pixels	WinLoadTab2	npix2
h'130	12	w	Selection for peaking / coring	WinLoadTab2	peaking2
h'131	12	w	Brightness	WinLoadTab2	brightness2

FP-RAM					
Address Hex	Number of Bits	Mode	Function	Group	Name
h'132	12	w	Contrast	WinLoadTab2	contrast2
h'134	12	w	Start line even field	VBI-window	start_even
h'135	12	w	End line even field	VBI-window	end_even
h'136	12	w	Start line odd field	VBI-window	start_odd
h'137	12	w	End line odd field	VBI-window	end_odd
h'138	12	w	Control VBI-Window	VBI-window	vbicontrol
h'139	12	w	Slicer Data Size	VBI-window	slsize
h'140	12	w r	Register for control and latching		ControlWord
h'141	12	r	Internal status register, do not overwrite		InfoWord
h'150	12	w	Format Selection / Shuffler / PIXCLK-mode	Formatter	format_sel
h'151	12	w	Start position of the programmable 'video active'	HVREF	pval_start
h'152	12	w	End position of the programmable 'video active'	HVREF	pval_stop
h'153	12	w	Length and polarity of HREF, VREF, FIELD	HVREF	refsig
h'154	12	w	Output Multiplexer / Multi-purpose output	Output Mux.	outmux
h'157	12	w	Number of frames to output within 3000 frames	Temp. Decim.	tdecframes

6.1.1. Description of I<sup>2</sup>C Control and Status Registers

Table 6–1: I<sup>2</sup>C-Registers VPX Front-End

I <sup>2</sup> C-Registers VPX Front-End					
Address Hex	Number of bits	Mode	Function	Default	Name
<b>FP Interface</b>					
h'35	8	r	FP status bit [0] write request bit [1] read request bit [2] busy		FPSTA
h'36	16	w	FP read bit [8:0] 9-bit FP read address bit [11:9] reserved, set to zero		FPRD
h'37	16	w	FP write bit [8:0] 9-bit FP write address bit [11:9] reserved, set to zero		FPWR
h'38	16	w/r	FP data bit [11:0] FP data register, reading/writing to this register will autoincrement the FP read/write address. Only 16 bit of data are transferred per I <sup>2</sup> C telegram.		FPDAT

Table 6–2: I<sup>2</sup>C-Registers VPX Back-End

I <sup>2</sup> C-Registers VPX Back-End					
Address Hex	Number of bits	Mode	Function	Default	Name
<b>Chip Identification</b>					
h'00	8	r	Manufacture ID in accordance with JEDEC Solid State Products Engineering Council, Washington DC Micronas Code EC <sub>hex</sub>		JEDEC
h'01 h'02	8 8	r r	16 bit part number (01: LSBs, 02: MSBs) VPX 3225D 7230 <sub>hex</sub> ; VPX 3224D 7231 <sub>hex</sub>		PARTNUM partlow parthigh
h'03	8	r	JEDEC2		JEDEC2
			bit [0] : IFIELD		ifield
			bit [7:1] : reserved (must be treated don't care)		

I <sup>2</sup> C-Registers VPX Back-End					
Address Hex	Number of bits	Mode	Function	Default	Name
<b>Output</b>					
h'F8	8	w	Pad Driver Strength – TTL Output Pads Typ A		DRIVER_A
			bit [2:0] : Driver strength of Port A[7:0]		stra1
			bit [5:3] : Driver strength of PIXCLK, LLC, and VACT		stra2
			bit [7:6] : additional PIXCLK driver strength strength = bit [5:3]   {bit [7:6], 0}		stra3
h'F9	8	w	Pad Driver Strength – TTL Output Pads Typ B		DRIVER_B
			bit [2:0] : Driver strength of Port B[7:0]		strb1
			bit [5:3] : Driver strength of HREF, VREF, FIELD, and LLC2		strb2
			bit [7:6] : reserved (must be set to zero)		
h'F2	8	w	Output Enable		OENA
		direct	bit [0] : 1 Enable Video Port A 0 Disable / High Impedance Mode		aen
		direct	bit [1] : 1 Enable Video Port B 0 Disable / High Impedance Mode		ben
		direct	bit [2] : 1 Enable Pixclk Output 0 Disable / High Impedance Mode		clken
		direct	bit [3] : 1 Enable HREF, VREF, FIELD, VACT, LLC, LLC2 0 Disable / High Impedance Mode		zen
		direct	bit[4] 1 Enable LLC2 to TDO pin (if JTAG interface is in Test-Logic-Reset State) 0 Disable LLC2		llc2en
		direct	bit [5] : 1 no delay of OEQ input signal 0 1 LLC cycle delay of OEQ input signal (if bit [6] = 1)		oeqdel
		direct	bit [6] : 1 latch OEQ input signal with rising edge of LLC 0 don't latch OEQ input signal		latoeq
		direct	bit [7] : 1 disable OEQ pin function		oeq_dis
h'AA	8	w	Low power mode, LLC mode		LLC
			bit [1:0] : Low power mode 00 active mode, outputs enabled 01 outputs tri-stated; clock divided by 2, I <sup>2</sup> C full speed 10 outputs tri-stated; clock divided by 4, I <sup>2</sup> C full speed 11 outputs tri-stated; clock divided by 8, I <sup>2</sup> C < 100 kbit/s		lowpow
			bit [2] : I <sup>2</sup> C reset		iresen
			bit [3] : 1 connect LLC2 to TDO pin 0 connect bit[4] to TDO pin		llc2
			bit [4] : if bit[3] then bit[4] defines LLC2 polarity else bit[4] is connected to TDO pin		llc2_pol
			bit [5] : switch-off slicer (if slowpow = 1 then all slicer registers are reset).		slowpow
			bit [6] : 1 use old llc timing with long hold time 0 use new llc timing with shorter hold time (version D4 only)		oldllc
			bit [7] : reserved (must be set to zero)		

**Table 6–3: I<sup>2</sup>C-Registers VPX Slicer**

I <sup>2</sup> C-Registers VPX Slicer					
Address Hex	Number of bits	Mode	Function	Default	Name
<b>Sync Slicer</b>					
h'C8	8	w	sync slicer bit [6:0]: binary sync slicer level is compared with binary data (0 ≤ data ≤ 127) bit [7]: 0 vertical sync window enable 1 vertical sync window disable	64 0	sync_slicer sync_level vsw
h'B4	8	r	sync status bit [5:0]: reserved (must be read don't care) bit [6]: 0 vert. window reset at line 624/524 (PAL/NTSC) 1 vert. retrace set at line 628/528 (PAL/NTSC) bit [7]: 0 field 2 reset at line 313/263 (PAL/NTSC) 1 field 1 set at line 624/524 (PAL/NTSC)		sync_stat vwin field
h'B5	8	r	hsync counter bit [7:0]: number of detected horizontal sync pulses per frame / 4 sync is detected within horizontal window of HPLL counter is latched with vertical sync the register can be read at any time		sync_cnt
<b>Bit Slicer</b>					
h'C0	8	w	soft slicer bit [6:0]: binary soft slicer level is compared with ABS[data] (-128 ≤ data ≤ +127) bit [7]: reserved (must be set to zero)	16	soft_slicer soft_level
h'C1 h'C2	8 8	w w	ttx bitslicer frequency LSB ttx bitslicer frequency MSB bit [10:0]: Freq = 2 <sup>11</sup> * bitfreq / 20.25MHz = 702 for WST PAL = 579 for WST NTSC or NABTS = 506 for VPS or WSS = 102 for CAPTION = 627 for Antiope = 183 for Time Code bit [11]: 0 phase inc = Freq 1 phase inc = Freq*(1+1/8) before framing code phase inc = Freq*(1+1/16) after framing code bit [15:12]: reserved (must be set to zero)	702 1 0	ttx_freql ttx_freqh ttx_freq ttx_phinc
h'C5	8	w	filter coefficient bit [5:0]: high pass filter coefficient in 2's complement 100000 = not allowed 100001 = -31 000000 = 0 011111 = +31 bit [7:6]: reserved (must be set to zero)	7	filter coeff
h'C6	8	w	data slicer bit [7:0]: binary data slicer level is compared with ABS[data] (-128 ≤ data ≤ +127)	64	data_slicer data_level

I <sup>2</sup> C-Registers VPX Slicer					
Address Hex	Number of bits	Mode	Function	Default	Name
h'C7	8	w	accumulator mode bit [0] : 0 no action 1 reset DC and AC and FLT accu (one shot) bit [1] : 0 DC accu enable 1 DC accu disable bit [2] : 0 AC and FLT accu enable 1 AC and FLT accu disable (only for VPS and CAPTION and WSS line) bit [3] : 0 soft error correction enable 1 soft error correction disable bit [4] : 0 ac adaption disable 1 ac adaption enable bit [5] : 0 flt adaption disable 1 flt adaption enable bit [7:6] : reserved (must be set to zero)	0 0 1 0 1 1	accu reset dcen acen soften acaden fltaden
h'B6	8	r	read filter coefficient		coeff_rd
h'B7	8	r	read data slicer level		level_rd
Byte Slicer					
h'B3	8	r	soft error counter bit [7:0] : counts number of soft error corrected bytes counter stops at 255 reset after read		soft_cnt
h'C9	8	w	standard bit [0] : 0 TTX disable 1 TTX enable bit [1] : 0 PAL mode 1 NTSC mode bit [2] : 0 full field disable 1 full field enable bit [3] : 0 VPS line 16 disable 1 VPS line 16 enable bit [4] : 0 WSS line 23 disable 1 WSS line 23 enable bit [5] : 0 CAPTION line 21 field 1 disable 1 CAPTION line 21 field 1 enable bit [6] : 0 CAPTION line 21 field 2 disable 1 CAPTION line 21 field 2 enable bit [7] : 0 horizontal quit signal enable 1 horizontal quit signal disable	1 0 0 1 1 0 0 0	standard ttx ntsc full vps wss caption1 caption2 disquit
h'BD h'BC h'BB	8 8 8	w w w	clock run-in and framing code reference low clock run-in and framing code reference mid clock run-in and framing code reference high bit [23:0] : clock run-in and framing code reference (LSB corresponds to first transmitted bit)	h'55 h'55 h'27	reference
h'BA h'B9 h'B8	8 8 8	w w w	clock run-in and framing code don't care mask low clock run-in and framing code don't care mask mid clock run-in and framing code don't care mask high bit [23:0] : clock run-in and framing code don't care mask (LSB corresponds to first transmitted bit)	h'00 h'00 h'00	mask
h'CE	8	w	bit error tolerance bit [1:0] : maximum number of bit errors in low mask bit [3:2] : maximum number of bit errors in mid mask bit [5:4] : maximum number of bit errors in high mask bit [7:6] : reserved (must be set to zero)	1 1 1	tolerance
h'CF	8	w	output mode bit [5:0] : number of data bytes per text line including framing code bit [6] : 0 64 byte mode disable 1 64 byte mode enable bit [7] : 0 data output only for text lines 1 data output for every video line	43 1 0	out_mode byte_cnt fill64 dump

6.1.2. Description of FP Control and Status Registers

Table 6–4: FP-RAM VPX Front-End

FP-RAM VPX Front-End					
Address Hex	Number of Bits	Mode	Function	Default	Name
<b>Standard Selection</b>					
h'20	12	w	Standard select: bit [2:0] standard 0 PAL B,G,H,I (50 Hz) 4.433618 1 NTSC M (60 Hz) 3.579545 2 SECAM (50 Hz) 4.286 3 NTSC44 (60 Hz) 4.433618 4 PAL M (60 Hz) 3.575611 5 PAL N (50 Hz) 3.582056 6 PAL 60 (60 Hz) 4.433618 7 NTSC COMB (60 Hz) 3.579545 bit [3] 0/1 MOD standard modifier PAL modified to simple PAL NTSC modified to compensated NTSC SECAM modified to monochrome 625 NTSCC modified to monochrome 525 bit [5:4] reserved; must be set to zero bit [6] 0/1 S-VHS mode off/on Option bits allow to suppress parts of the initialization: bit [7] no hpll setup bit [8] no vertical setup bit [9] no acc setup bit [10] reserved, set to zero bit [11] status bit, write 0. After the FP has switched to a new standard, this bit is set to 1 to indicate operation complete.	0	sdt pal ntsc secam ntsc44 palm paln pal60 ntsc sdtmod  svhs  sdtopt
h'21	12	w	Input select: Writing to this register will also initialize the standard. bit [1:0] luma selector 00 VIN3 01 VIN2 10 VIN1 11 reserved bit [2] chroma selector 0/1 VIN1/CIN bit [4:3] IF compensation 00 off 01 6 dB/Okt 10 12 dB/Okt 11 10 dB/MHz only for SECAM bit [6:5] chroma bandwidth selector 00 narrow 01 normal 10 broad 11 wide bit [7] 0/1 adaptive/fixd SECAM notch filter bit [8] 0/1 enable luma lowpass filter bit [10:9] hpll speed 00 no change 01 terrestrial 10 vcr 11 mixed bit [11] status bit, write 0; This bit is set to 1 to indicate operation complete.	00  1 00  01	insel vis  cis  ifc  cbw  fntch lowp hpllmd
h'22	12	w	picture start position, This register sets the start point of active video. This can be used e.g. for panning. The setting is updated when 'sdt' register is updated	0	sfif
h'23	12	w	luma/chroma delay adjust, The setting is updated when 'sdt' register is updated bit [5:0] reserved, set to zero bit [11:6] luma delay in clocks, allowed range is +1 ... -7	0	ldly



FP-RAM VPX Front-End					
Address Hex	Number of Bits	Mode	Function	Default	Name
<b>Color Processing</b>					
h'30	12	w	ACC reference level to adjust $C_r$ , $C_b$ levels on picture bus. A value of 0 disables the ACC, chroma gain can be adjusted via ACCb / ACCr register. The setting is updated when 'sdt' register is updated.	P/N: 2070 S: 0	accref
h'32	12	w	ACC multiplier value for SECAM Db chroma component to adjust $C_b$ level on picture bus. The setting is updated when 'sdt' register is updated. b [10:0] eeemmmmmmm $m * 2^{-e}$	S: 1155	accb
h'33	12	w	ACC multiplier value for SECAM Dr chroma component to adjust $C_r$ level on picture bus. The setting is updated when 'sdt' register is updated. b [10:0] eeemmmmmmm $m * 2^{-e}$	S: 1496	accr
h'39	12	w	amplitude killer level (0: killer disabled)	25	kilvl
h'3A	12	w	amplitude killer hysteresis	5	kilhy
h'DC	12	w	NTSC tint angle, $\pm 512 = \pm \pi/4$	0	tint
<b>DVCO</b>					
h'F8	12	w	crystal oscillator center frequency adjust, -2048 ... 2047	-720	dvco
h'F9	12	r	crystal oscillator center frequency adjustment value for line-locked mode, true adjust value is DVCO - ADJUST. For factory crystal alignment, using standard video signal: set DVCO = 0, set lock mode, read crystal offset from ADJUST register and use negative value for initial center frequency adjustment via DVCO.		adjust
h'F7	12	w/r	crystal oscillator line-locked mode, lock command/status write: 100 enable lock 0 disable lock read: 4095/0 locked/unlocked	0	xlck
<b>FP Status Register</b>					
h'12	12	w/r	general purpose control bits bit [2:0] reserved, do not change bit [3] vertical standard force bit [8:4] reserved, do not change bit [9] disable flywheel interlace bit [11:10] reserved, do not change  to enable vertical free run mode set vfrc=1 and dflw=0	0  1	gp_ctrl vfrc dflw
h'13	12	r	automatic standard recognition status bit [0] 1 vertical lock bit [1] 1 horizontally locked bit [2] 1 no signal detected bit [3] 1 color amplitude killer active bit [4] 1 disable amplitude killer bit [5] 1 color ident killer active bit [6] 1 disable ident killer bit [7] 1 interlace detected bit [8] 1 no vertical sync detection bit [9] 1 spurious vertical sync detection bit [11:10] reserved		asr
h'CB	12	r	number of lines per field, P/S: 312, N: 262		nlpf
h'15	12	w/r	vertical field counter, incremented per field		vcnt
h'74	12	r	measured sync amplitude value, nominal: 768		sampl
h'31	12	r	measured burst amplitude		bampl
h'F0	12	r	software version number bit [7:0] internal software revision number bit [11:8] software release	x	

FP-RAM VPX Front-End					
Address Hex	Number of Bits	Mode	Function	Default	Name
<b>Macrovision Detection (version D4 only)</b>					
h'170	12	r	Status of macrovision detection		mcv_status
			bit [0]: AGC pulse detected		
			bit [1]: pseudo sync detected		
h'171	12	w	first line of macrovision detection window	6	mcv_start
h'172	12	w	last line of macrovision detection window	15	mcv_stop

**Table 6–5:** FP-RAM VPX Back-End

FP-RAM VPX Back-End					
Address Hex	Number of Bits	Mode	Function	Default	Name
<b>Read Table for Window #1</b>					
h'10f	12	r	Position of VACT		
			bit [11:1]: Delay of VACT relative to the trailing edge of HREF		vact_delay1
<b>Load Table for Window #1 (WinLoadTab1)</b>					
h'120	12	w	Vertical Begin	12	
			bit [8:0]: Vertical Begin (first active video line within a field) min. line number for 625/50 standards: 7 min. line number for 525/60 standards: 10 max. line number: determined by current TV line standard		vbeg1
			bit [11:9]: reserved (must be set to zero)		
h'121	12	w	Vertical Lines In	0	
			bit [8:0]: Number of input lines determines the range between the first and the last active video line within a field; vbeg + vlinei should not exceed the max. number of lines determined by the current line standard (exceeding values will be corrected automatically)		vlinei1
			bit [9]: enable temporal decimation (0: off, 1: on) with temporal decimation enabled, only the number of frames selected in register h'157 (tdecframes) will be output within an interval of 3000 frames		tdec1
			bit [11:10]: field disable flags 11 Window disabled 10 Window enabled in ODD fields only 01 Window enabled in EVEN fields only 00 Window enabled in both fields		
h'122	12	w	Vertical Lines Out	0	
			bit [8:0]: Number of output lines vlineout cannot be greater than vlinein (no interpolation); for vlineout < vlinein vertical compression via line dropping is applied		vlineo1
			bit [11:9]: reserved (must be set to zero)		
h'123	12	w	Horizontal Begin	0	
			bit [10:0]: Horizontal start of window after scaling (relative to npix) hbeg > 0 enables cropping on the left side of the window		hbeg1
			bit [11]: reserved (must be set to zero)		
h'124	12	w	Horizontal Length	704	
			bit [10:0]: Horizontal length of window after scaling (relative to npix) hbeg + hlen cannot exceed npix		hlen1
			bit [11]: reserved (must be set to zero)		
h'125	12	w	Number of Pixels	704	
			bit [10:0]: Number of active pixels for the full active line (after scaling) npix must be an even value within the range 32...864		npix1
			bit [11]: reserved (must be set to zero)		

FP-RAM VPX Back-End					
Address Hex	Number of Bits	Mode	Function	Default	Name
h'126	12	w	Selection for peaking/coring	0	peaking1
			bit [1:0]: coring subtracts LSBs of the higher frequency part of the video signal 00: subtract 0 LSBs 01: subtract 1/2 LSB 10: subtract 1 LSB 11: subtract 2 LSBs		
			bit [4:2]: peaking an implemented peaking filter supports sharpness control with up to eight steps: 000: no peaking 001: low peaking 111: high peaking		
			bit [5]: Bypass Lowpass		
			bit [6]: Bypass Skewfilter		
			bit [7]: Bypass Skewfilter VACT		
			bit [8]: Swapping of Chroma values 0 Cb-Pixels first 1 Cr-Pixels first		
			bit [11:9]: reserved (must be set to zero)		
h'127	12	w	Brightness	0	
			bit [7:0]: Brightness Level offset value added to the video samples brightness can be selected in 256 steps within the range -127 ... 128 (binary offset format): 0: -127 255: 128		brightness1
			bit [11:8]: reserved (must be set to zero)		
h'128	12	w	Contrast	32	contrast1
			bit [5:0]: Contrast Level linear scale factor for luminance (default = 1.0) [5] integer part [4:0] fractional part		contr1
			bit [7:6]: Noise Shaping Control for 10-bit to 8-bit conversion (default: rounding) 00: 9-bit to 8-bit via 1-bit rounding 01: 9-bit to 8-bit via truncation 10: 9-bit to 8-bit via 1-bit accumulation 11: 10-bit to 8-bit via 2-bit accumulation		noise1
			bit [8]: Contrast Brightness: Clamping Level 0 clamping level = 32, 1 clamping level = 16 (should normally be set to 1)		clamp1
			bit [9]: Bypass Brightness Adder		bribyp1
			bit [10]: Bypass Contrast Multiplier		conbyp1
			bit [11]: reserved (must be set to zero)		

FP-RAM VPX Back-End					
Address Hex	Number of Bits	Mode	Function	Default	Name
<b>Read Table for Window #2</b>					
h'11f	12	r	Position of VACT		
			bit [11:1]: Delay of VACT relative to the trailing edge of HREF		vact_delay2
<b>Load Table for Window #2 (WinLoadTab2)</b>					
h'12A	12	w	Vertical Begin	17	
			bit [8:0]: Vertical Begin (first active video line within a field) min. line number for 625/50 standards: 7 min. line number for 525/60 standards: 10 max. line number: determined by current TV line standard		vbeg2
			bit [11:9]: reserved (must be set to zero)		
h'12B	12	w	Vertical Lines In	500	
			bit [8:0]: Number of input lines determines the range between the first and the last active video line within a field; vbeg + vlinei should not exceed the max. number of lines determined by the current line standard (exceeding values will be corrected automatically)		vlinei2
			bit [9]: enable temporal decimation (0: off, 1: on) with temporal decimation enabled, only the number of frames selected in register h'157 (tdecframes) will be output within an interval of 3000 frames		tdec2
h'12C	12	w	Vertical Lines Out	240	
			bit [8:0]: Number of output lines vlineout cannot be greater than vlinein (no interpolation); for vlineout < vlinein vertical compression via line dropping is applied		vlineo2
			bit [11:9]: reserved (must be set to zero)		
h'12D	12	w	Horizontal Begin	0	
			bit [10:0]: Horizontal start of window after scaling (relative to npix) hbeg > 0 enables cropping on the left side of the window		hbeg2
			bit [11]: reserved (must be set to zero)		
h'12E	12	w	Horizontal Length	640	
			bit [10:0]: Horizontal length of window after scaling (relative to npix) hbeg + hlen can not exceed npix		hlen2
			bit [11]: reserved (must be set to zero)		
h'12F	12	w	Number of Pixels	640	
			bit [10:0]: Number of active pixels for the full active line (after scaling) npix must be an even value within the range 32...864		npix2
			bit [11]: reserved (must be set to zero)		

FP-RAM VPX Back-End					
Address Hex	Number of Bits	Mode	Function	Default	Name
h'130	12	w	Selection for peaking/coring	0	peaking2
			bit [1:0]: coring subtracts LSBs of the higher frequency part of the video signal 00: subtract 0 LSBs 01: subtract 1/2 LSB 10: subtract 1 LSB 11: subtract 2 LSBs		
			bit [4:2]: peaking an implemented peaking filter supports sharpness control with up to eight steps: 000: no peaking 001: low peaking 111: high peaking		
			bit [5]: Bypass Lowpass		
			bit [6]: Bypass Skewfilter		
			bit [7]: Bypass Skewfilter VACT		
			bit [8]: Swapping of Chroma values 0 Cb-Pixels first 1 Cr-Pixels first		
			bit [11:9]: reserved (must be set to zero)		
h'131	12	w	Brightness	0	
			bit [7:0]: Brightness Level offset value added to the video samples brightness can be selected in 256 steps within the range -127 ... 128 (binary offset format): 0: -127 255: 128		brightness2
			bit [11:8]: reserved (must be set to zero)		
h'132	12	w	Contrast	32	contrast2
			bit [5:0]: Contrast Level linear scale factor for luminance (default = 1.0) [5] integer part [4:0] fractional part		contr1
			bit [7:6]: Noise Shaping Control for 10-bit to 8-bit conversion (default: rounding) 00: 9-bit to 8-bit via 1-bit rounding 01: 9-bit to 8-bit via truncation 10: 9-bit to 8-bit via 1-bit accumulation 11: 10-bit to 8-bit via 2-bit accumulation		noise1
			bit [8]: Contrast Brightness: Clamping Level 0 clamping level = 32, 1 clamping level = 16 (should normally be set to 1)		clamp1
			bit [9]: Bypass Brightness Adder		bribyp1
			bit [10]: Bypass Contrast Multiplier		conbyp1
			bit [11]: reserved (must be set to zero)		

FP-RAM VPX Back-End					
Address Hex	Number of Bits	Mode	Function	Default	Name
<b>Load Table for VBI-Window</b>					
h'134	12	w	Start line even field determines the first line of the VBI-window within even fields (note that lines are counted relative to the whole frame!)	272	start_even
h'135	12	w	End line even field determines the last line of the VBI-window within even fields (note that lines are counted relative to the whole frame!)	283	end_even
h'136	12	w	Start line odd field determines the first line of the VBI-window within odd fields	10	start_odd
h'137	12	w	End line odd field determines the last line of the VBI-window within odd fields	21	end_odd
h'138	12	w	Control VBI-Window	0	vbicontrol
			bit [0]: VBI-window enable the selected VBI-window is activated only if this flag is set 0: disable 1: enable		vbien
			bit [1]: VBI mode two modes for the output of VBI-data are supported 0: raw data 1140 samples of the video input are given directly to the output 1: sliced data sliced teletext data (in a package of 64 bytes)		vbimode
			bit [2]: vertical identification the valid VBI-lines defined by the VBI-window can either be marked as active or as blanked lines 0: active lines during VBI-window (VACT enabled) 1: blanked lines during VBI-window (VACT suppressed)		vbident
			bit [11]: update the settings for the VBI-window (settings will only be updated if this latch flag is set!)		vbilatch
h'139	12	w	Slicer Data Size (0 corresponds to default value 64)	0	slsize

FP-RAM VPX Back-End					
Address Hex	Number of Bits	Mode	Function	Default	Name
<b>Control Word</b>					
h'140	12	w r	Register for control and latching		Control Word
		w	bit [1:0]: Sync timing mode 00 Open mode horizontal and vertical sync are tracking the input signal 10 Scan mode horizontal and vertical sync are free running	0	settm
		w	bit [2]: Mode for VACT reference signal 0 length of VACT corresponds to the size of the current window 1 programmable length of VACT (for the whole field!)	0	vactmode
		w	bit [4:3]: reserved (must be set to zero)	0	
		w	bit [5]: Latch Window #1 1 latch (reset automatically)	1	latwin1
		w	bit [6]: Latch Window #2 1 latch (reset automatically)	1	latwin2
			bit [9]: reserved (must be set to zero)	0	
			bit [10]: Latch value for temporal decimation The number of frames for the temporal decimation is updated only if this flag is set 1 latch (reset automatically)	1	lattdec
		w	bit [11]: Latch Timing Modes Selection of the timing mode is updated only if this flag is set 1 latch (reset automatically)	1	lattm
<b>Info Word</b>					
h'141	12	r	Internal status register, do not overwrite This register can be used to query the current internal state due to the settings in the control word.		InfoWord
			bit [2]: Mode for VACT reference signal 0 current window size 1 programmable size		actvact
			bit [4:3]: reserved		
			bit [11:8]: reserved		



FP-RAM VPX Back-End					
Address Hex	Number of Bits	Mode	Function	Default	Name
<b>Formatter</b>					
h'150	12	w	Format Selection		format_sel
			bit [1:0]: Format Selector 00: YUV 4:2:2, ITU-R601 01: YUV 4:2:2, ITU-R656 10: YUV 4:2:2, BStream	0	format
			bit [2]: Shuffler 0 Port A = Y, Port B = UV 1 Port A = UV, Port B = Y	0	shuf
			bit [3]: Format of VBI-data (in ITU-R656 mode only!) Two possibilities are supported to disable the protected values 0 and 255: 0 limitation 1 7-bit resolution + odd parity LSB Note that this selection is applied for lines within the VBI-window only!	0	range
			bit [4]: Transmission of VBI-data (in ITU-R656 mode only) 0 transmit as normal video data 1 transmit as ancillary data (with ANC-header)	1	ancillary
			bit [5]: PIXCLK selection Setting this bit activates the half-clock mode, in which PIXCLK is divided by 2 in order to spread the video data stream 0 full PIXCLK (normal operation) 1 PIXCLK divided by 2	0	halfclk
			bit [6]: Disable splitting of text data bytes During normal operation, sliced teletext bytes are splitted into 2 nibbles and multiplexed to the luminance and chrominance part. Setting this bit will disable this splitting. Sliced teletext data will be output directly on the luminance path. Note that the limitation of luminance data has to be disabled with bit [8]. The values 0 and 255 will no longer be protected in the luminance path!	0	splitdis
			bit [7]: reserved (must be set to zero)	0	
			bit [8]: Disable limitation of luminance data (see bit [6]) 0 enabled 1 disabled	0	dislim
			bit [9]: Suppress ITU-R656 headers for blank lines	0	hsup
			bit [10]: Change of ITU-R656 header flags 0 change header flags in SAV 1 change header flags in EAV	0	flagdel
			bit [11]: reserved (must be set to zero)	0	

FP-RAM VPX Back-End					
Address Hex	Number of Bits	Mode	Function	Default	Name
<b>HVREF</b>					
h'151	12	w	Start position of the programmable 'video active' The start position has to be an even value and is given relative to the trailing edge of HREF. Programmable VACT is activated with bit [2] of the control word (h'140)!	40	pval_start
			bit [10:0]: start of VACT reference signal		
h'152	12	w	End position of the programmable 'video active' The end position has to be an even value and is given relative to the trailing edge of HREF.	720	pval_stop
			bit [10:0]: end of VACT reference signal		
h'153	12	w	HREF and VREF control determines length and polarity of the timing reference signals		refsig
			bit [0]: Odd/Even polarity 0 odd high 1 even high	0	oepol
			bit [1]: HREF Polarity 0 active high 1 active low	0	hpol
			bit [2]: VREF Polarity 0 active high 1 active low	0	vpol
			bit [5:3]: VREF pulse width, binary value + 2 000: pulse width = 2 111: pulse width = 9	0	vlen
			bit [6]: 1 disables field as output setting this bit will force the 'field' pin to the high impedance state	0	disfield
<b>Output Multiplexer</b>					
h'154	12	w	Output Multiplexer	0	outmux
			bit [7:0]: Multi-purpose bits on Port B determines the state of Port B when used as programmable output		bmp
			bit [8]: activate multi-purpose bits on Port B note that double clock mode has to be selected for this option!		bmpen
			bit [9]: Port Mode 0 parallel_out, 'single clock', Port A & B = FO[15:0]; 1 'double clock' Port A = FO[15:8] / FO[7:0], Port B = programmable output/not used;		double
			bit [10]: switch 'VBI active' qualifier 0 connect 'VBI active' to VACT pin 1 connect 'VBI active' to TDO pin		vbiact
			bit [11]: reserved (must be set to zero)		
<b>Temporal Decimation</b>					
h'157	12	w	Number of frames to output within 3000 frames This value will be activated only if the corresponding latch flag is set (control word h'140, bit [10]).	3000	tdecframes

**7. Application Notes**

**7.1. Differences between VPX 3220A and VPX 322xD**

The following items indicate the differences between the VPX 322xD and the VPX 3220A:

**Internal**

- The control registers (I<sup>2</sup>C and FP-RAM) contain significant changes.
- VPX 322xD incorporates a text slicer. Furthermore, raw ADC data is supported (sampling frequency of 20.25 MHz/8 bit, output data rate 13.5 MHz/16 bit).
- VPX 322xD does not support RGB and compressed video data output formats. The VPX 322xD supports ITU-R601 and ITU-R656.
- The VPX 322xD does not provide an asynchronous output mode, PIXCLK functions as an output only. The VPX 322xD supports half-clock data rate (6.75 MHz).
- The VPX 322xD does not provide a video data rate of 20.25 MHz at the output interface.
- The VPX 322xD has an implemented low power mode.

**External**

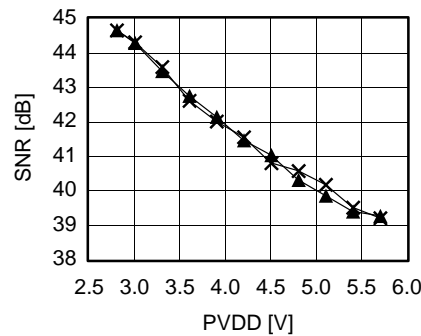
- Power-up Default Selection

Selection	VPX 3220A	VPX 322xD
I <sup>2</sup> C device address	PREF	OE
wake-up default Pads tristate/active	PIXCLK	FIELD

- The VPX 322xD does not use the internal I<sup>2</sup>C bus for power-up initialization. Resultingly, the I<sup>2</sup>C interface will not be locked during that period.
- The VPX 322xD supports an 8-bit programmable output port if the device uses only A[7:0] for video data output.
- The VPX 322xD provides a HREF signal with a fixed low period, whereas the width of the high period will vary while the video input signal varies.

**7.2. Impact to Signal to Noise Ratio**

Fig. 7-1 shows the impact of the variation of the power supply with respect to the SNR of the ADCs. The noise due to the digital output interface leads to an impact of the analog performance of the analog ADCs. Application engineers should minimize load capacitances and driver strength of the output signals.



**Fig. 7-1:** Dependency between SNR and Power Supply

**Note:** Both ADCs are working and routed to A[7:0], and B[7:0]. All interfaces are working with maximum driver strength bandwidth measurement is performed up to 5 MHz.

**7.3. Control Interface**

**7.3.1. Symbols**

- < Start Condition
- > Stop Condition
- aa (Sub-)Address Byte
- dd Data Byte

**7.3.2. Write Data into I<sup>2</sup>C Register**

<86 f2 dd> write to register OENA

**7.3.3. Read Data from I<sup>2</sup>C Register**

<86 00 <87 dd> read Manufacture ID

**7.3.4. Write Data into FP Register**

<86 35 <87 dd> poll busy bit[2] until it is cleared  
 <86 37 aa aa> write FP register write address  
 <86 35 <87 dd> poll busy bit[2] until it is cleared  
 <86 38 dd dd> write data into FP register

**7.3.5. Read Data from FP Register**

<86 35 <87 dd> poll busy bit[2] until it is cleared  
 <86 36 aa aa> write FP register read address  
 <86 35 <87 dd> poll busy bit[2] until it is cleared  
 <86 38 <87 dd dd> read data from FP register

### 7.3.6. Sample Control Code

A Windows API function set is provided for controlling the VPX. This API is independent of the actual used version of the VPX. It is recommended to control the VPX via this API, which allows flexible switching between different VPX family members. The API is available on request. The following code demonstrates the usage of the API to initialize the VPX.

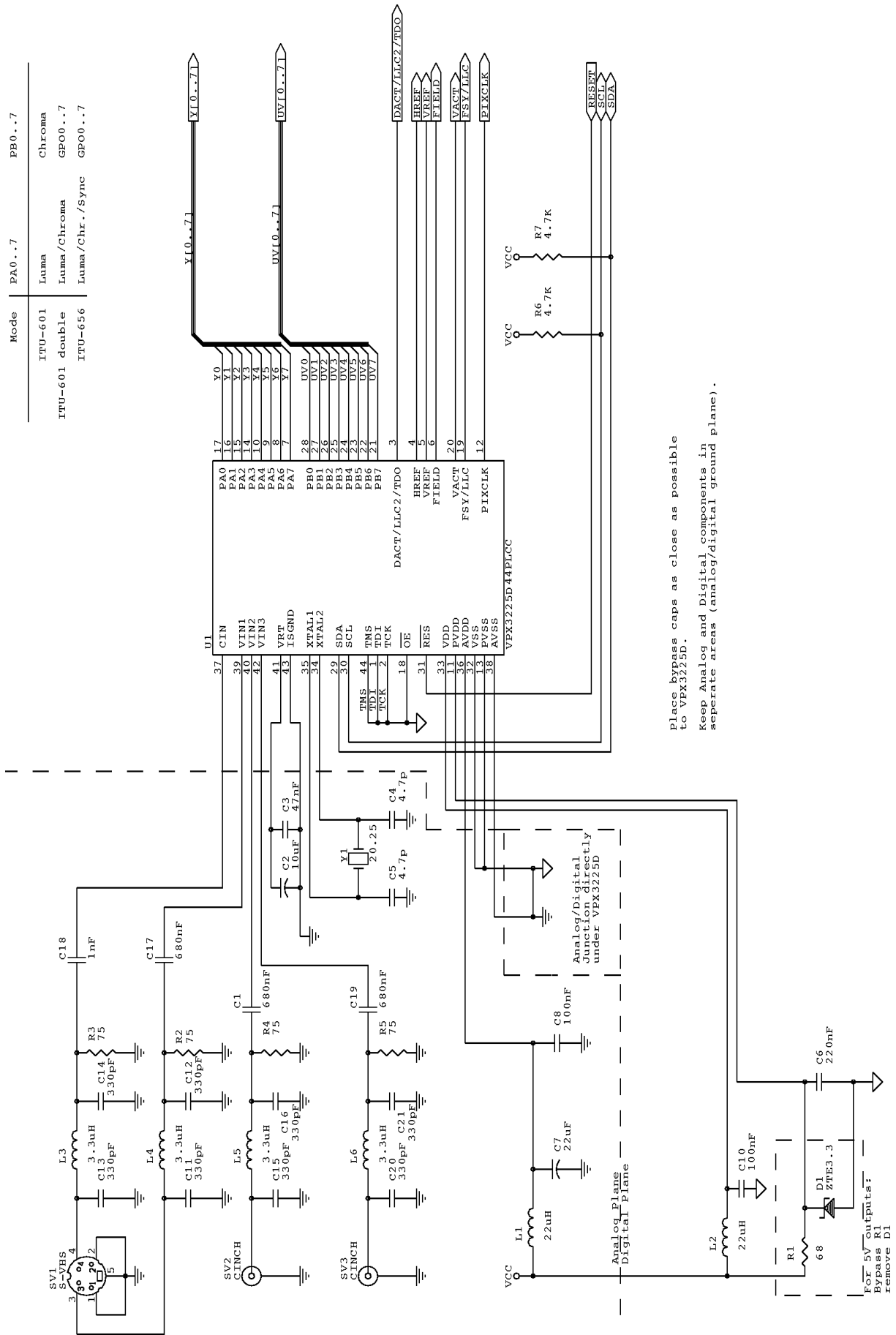
```
#include <vpX.h> // VPXAPI support header

VPXInit(); // initializes the VPX from an INI file
VPXSetVideoSource(VPX_VIN1, VPX_COMPOSITE);
VPXSetVideoWindow(VPX_VIDEO_WINDOW1, 23, 288, 0, 720, 720, 3000, 0);
VPXSetVideoWindow(VPX_VIDEO_WINDOW2, 0, 0, 0, 0, 0, 0, 0);
VPXSetVideoWindow(VPX_VBI_WINDOW, 320, 336, 7, 23, 0, 0, 0);
VPXSetVideoStandard(VPX_PAL);
VPXSetVBIMode(VPX_VBI_SLICED_DATA, VPX_VBI_ACTIVE);
VPXSetVideoAttribute(VPX_VIDEO_WINDOW1, VPX_CONTRAST, 128);
VPXSetVideoAttribute(VPX_VIDEO_WINDOW1, VPX_BRIGHTNESS, 128);
VPXSetVideoAttribute(VPX_VIDEO_WINDOW1, VPX_SATURATION, 128);
VPXSetVideoAttribute(VPX_VIDEO_WINDOW1, VPX_HUE, 128);
VPXSetVideoAttribute(VPX_VIDEO_WINDOW1, VPX_PEAKING, 128);
VPXSetVideoAttribute(VPX_VIDEO_WINDOW1, VPX_CORING, 128);
```

### 7.4. Xtal Supplier

Name	Part No.	Country	Phone	Contact	Notes
Acal Auremia	2351051	Germany	+49 (713) 15810		Crystal Holder HC49U
Lap Tech	XT1750	Canada	(905) 623 4101	Bob Parkins	Specify 13 pF Load Cap
Monitor Product Co.	MM 49x-5297	USA	(619) 433-4510		
Mtron	5009-359@20.25	USA	(408) 257-3399	George Panos	

7.5. Typical Application







## 8. Data Sheet History

1. Preliminary data sheet: "VPX 3225D, VPX 3224D Video Pixel Decoders", Edition March 5, 1997, 6251-432-1PD. First release of the preliminary data sheet.

2. Preliminary data sheet: "VPX 3225D, VPX 3224D Video Pixel Decoders", Edition Nov. 9, 1998, 6251-432-2PD. Second release of the preliminary data sheet. Major changes:

- additional feature: macrovision detection
- format of ITU-R656 ancillary data modified
- new timing for LLC and  $\overline{OE}$  pins
- section 3.1.: package outline dimensions changed

Micronas GmbH  
Hans-Bunte-Strasse 19  
D-79108 Freiburg (Germany)  
P.O. Box 840  
D-79008 Freiburg (Germany)  
Tel. +49-761-517-0  
Fax +49-761-517-2174  
E-mail: docservice@micronas.com  
Internet: www.micronas.com

Printed in Germany  
Order No. 6251-432-2PD

All information and data contained in this data sheet are without any commitment, are not to be considered as an offer for conclusion of a contract, nor shall they be construed as to create any liability. Any new issue of this data sheet invalidates previous issues. Product availability and delivery are exclusively subject to our respective order confirmation form; the same applies to orders based on development samples delivered. By this publication, Micronas GmbH does not assume responsibility for patent infringements or other rights of third parties which may result from its use.

Further, Micronas GmbH reserves the right to revise this publication and to make changes to its content, at any time, without obligation to notify any person or entity of such revisions or changes.

No part of this publication may be reproduced, photocopied, stored on a retrieval system, or transmitted without the express written consent of Micronas GmbH.



## Preliminary Data Sheet Supplement

---

<b>Subject:</b>	New Package for VPX 3225D, VPX 3224D
<b>Data Sheet Concerned:</b>	VPX 3225D, VPX 3224D 6251-432-2PD, Edition Nov. 9, 1998
<b>Supplement:</b>	No. 6 / 6251-432-6PDS
<b>Edition:</b>	April 8, 1999

---

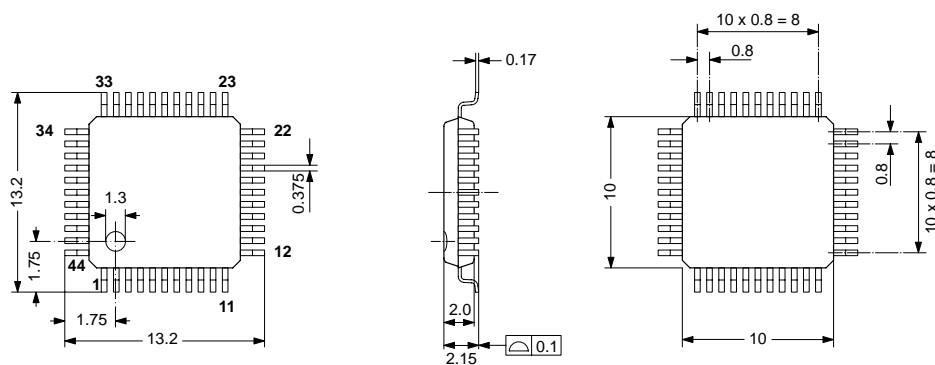
**New Package for the VPX 3225D–C3, VPX 3224D–C3**

1. The VPX 3225D–C3, VPX 3224D–C3 is also available in the PMQFP44 package.
2. The pinning of the PMQFP44 package has been changed, i.e. mirrored vertically.
3. Production of the PLCC44 package will continue.

Attachment: Package Information VPX 3225D, VPX 3224D

1. Specifications

1.1. Outline Dimensions



D0024/2E

**Fig. 1-1:**  
44-Pin Plastic Metric Quad Flat Pack  
**(PMQFP44)**  
Weight approx. 0.4 g  
Dimensions in mm

1.2. Pin Connections and Short Descriptions

NC = not connected; leave vacant  
LV = if not used, leave vacant  
X = obligatory

Pin No.	Pin Name	Pin Type	Connection (if not used)	Short Description
1	VIN1	AIN	NC	Analog Video 1 Input
2	AVSS	SUPPLY	X	Ground, Analog Circuitry
3	CIN	AIN	NC	Analog Chroma Input
4	AVDD	SUPPLY	X	Supply Voltage, Analog Circuitry
5	XTAL1	OSC IN	X	Analog Crystal Input
6	XTAL2	OSC OUT	X	Analog Crystal Output
7	VDD	SUPPLY	X	Supply Voltage, Digital Circuitry
8	VSS	SUPPLY	X	Ground, Digital Circuitry
9	RESQ	IN	X	Reset Input
10	SCL	IN/OUT	NC	I <sup>2</sup> C Bus Clock
11	SDA	IN/OUT	NC	I <sup>2</sup> C Bus Data
12	B0	OUT	NC	Port B - Video Data Output
13	B1	OUT	NC	Port B - Video Data Output
14	B2	OUT	NC	Port B - Video Data Output

Pin No.	Pin Name	Pin Type	Connection (if not used)	Short Description
15	B3	OUT	NC	Port B - Video Data Output
16	B4	OUT	NC	Port B - Video Data Output
17	B5	OUT	NC	Port B - Video Data Output
18	B6	OUT	NC	Port B - Video Data Output
19	B7	OUT	NC	Port B - Video Data Output
20	VACT	OUT	NC	Active Video Qualifier Output
21	LLC	OUT	NC	PIXCLK * 2 = 27 MHz Output
22	OEQ	IN	VSS	Output Ports Enable Input
23	A0	OUT	NC	Port A - Video Data Output
24	A1	OUT	NC	Port A - Video Data Output
25	A2	OUT	NC	Port A - Video Data Output
26	A3	OUT	NC	Port A - Video Data Output
27	PVSS	SUPPLY	X	Ground, Pad Circuits
28	PIXCLK	OUT	NC	Pixel Clock Output
29	PVDD	SUPPLY	X	Supply Voltage Pad Circuits

1.3. Pin Configuration

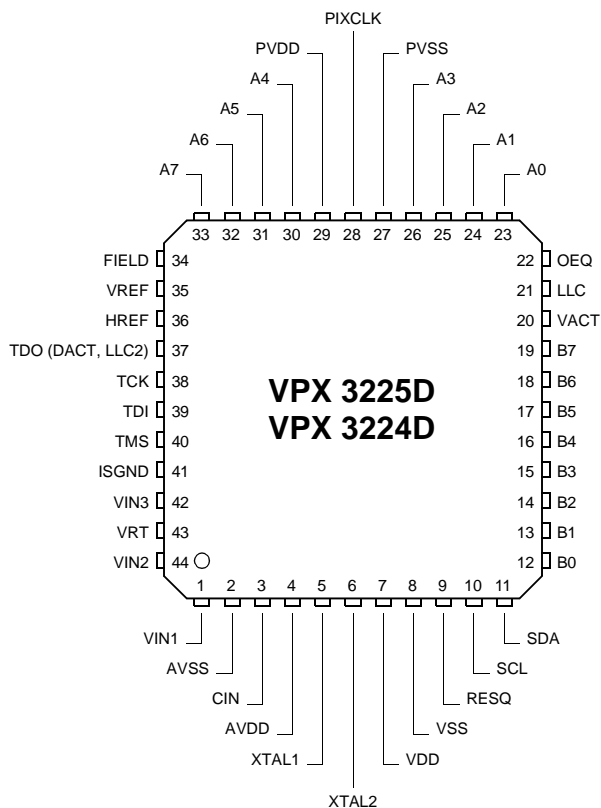


Fig. 1–2: 44-pin PMQFP package

1.4. Electrical Characteristics

1.4.1. Absolute Maximum Ratings

Symbol	Parameter	Pin Name	Min.	Max.	Unit
$T_A$	Ambient Temperature		0	55	°C
$T_S$	Storage Temperature		-40	125	°C
$T_J$	Junction Temperature		0	125	°C

Stresses beyond those listed in the “Absolute Maximum Ratings” may cause permanent damage to the device. This is a stress rating only. Functional operation of the device at these or any other conditions beyond those indicated in the “Recommended Operating Conditions/Characteristics” of this specification is not implied. Exposure to absolute maximum ratings conditions for extended periods may affect device reliability.